

Fujitsu Server BS2000 SE Series

Security Manual

User Guide

Valid for:
M2000 V6.3A
X2000 V6.3A
HNC V6.3A

Edition December 2019

Comments... Suggestions... Corrections...

The User Documentation Department would like to know your opinion on this manual. Your feedback helps us to optimize our documentation to suit your individual needs.

Feel free to send us your comments by e-mail to: bs2000services@ts.fujitsu.com.

Certified documentation according to DIN EN ISO 9001:2015

To ensure a consistently high quality standard and user-friendliness, this documentation was created to meet the regulations of a quality management system which complies with the requirements of the standard DIN EN ISO 9001:2015.

Copyright and Trademarks

Copyright © 2020 Fujitsu Technology Solutions GmbH.

All rights reserved.

Delivery subject to availability; right of technical modifications reserved.

All hardware and software names used are trademarks of their respective manufacturers.

The Xen® mark is a trademark of Citrix Systems, Inc., which manages the mark on behalf of the Xen open source community. The Xen® mark is registered with the U.S. Patent and Trademark Office, and may also be registered in other countries.

Novell and SUSE are registered brands of Novell, Inc. in the USA and other countries.

Linux is a registered brand of Linus Torvalds.

Windows® is a registered trademark of Microsoft Corporation.

The Linux-based basic software M2000, X2000, and HNC which is installed on the Management Unit, Server Unit x86, and HNC contains Open Source Software. The licenses for this can be found in the LICENSES directory on the relevant installation DVD.

Table of Contents

- Security Manual** 6
- 1 Introduction** 7
 - 1.1 Objective and target groups of this manual** 9
 - 1.2 Summary of contents** 10
 - 1.3 Changes to the predecessor manual** 11
 - 1.4 Notational conventions** 12
- 2 Architecture of the SE servers and networks** 13
 - 2.1 Hardware** 14
 - 2.2 Architecture of SE servers** 15
 - 2.3 Networks** 17
 - 2.4 Cluster** 19
- 3 Secure access to management functions** 20
 - 3.1 Role strategy and user accounts** 21
 - 3.1.1 Role strategy and role authorizations 22
 - 3.1.2 User accounts 24
 - 3.1.2.1 Centrally managed accounts (LDAP accounts) 25
 - 3.1.2.2 Authorization for account management 26
 - 3.1.2.3 Further accounts of the base system 27
 - 3.1.2.4 Accounts for add-on packs 28
 - 3.1.3 Authentication 29
 - 3.1.4 Password administration for local accounts 30
 - 3.1.5 Configuring access to an LDAP server 33
 - 3.2 Access to the SE Manager** 34
 - 3.2.1 Security settings on the administration PC 35
 - 3.2.2 Communication with encryption 36
 - 3.2.3 Session management 37
 - 3.3 Text-based access (at shell level)** 38
 - 3.3.1 Encrypted communication with Secure Shell 39
 - 3.3.2 No rights escalation 40
 - 3.3.3 Access functions in the SE Manager 41
 - 3.4 Alternative accesses with Secure Shell** 42
 - 3.4.1 Secure Shell host key 43
 - 3.4.2 Communication using Secure Shell keys 44
 - 3.4.3 Generating the keys 45
 - 3.4.4 Using SSH agents 47
 - 3.4.5 PuTTY with PuTTYgen and Pageant 49
 - 3.4.5.1 Key generator PuTTYgen 50

3.4.5.2 Authentication agent Pageant	51
3.5 Access via the local console	52
3.6 Access to the iRMC of the Management Unit	53
3.7 Protected access to the BIOS and the bootloader	54
4 Secure access to systems	55
4.1 Secure access to BS2000 systems	56
4.1.1 Security in the BS2000 operating system	57
4.1.2 Downloading KVP logging files	58
4.1.3 Alternative access to the BS2000 operating system with PuTTY	59
4.2 Secure access to systems on Application Units	60
4.2.1 Configuration changes	61
4.2.2 Access to the iRMC / Management Board of the Application Unit	62
4.2.3 Integration of Application Unit into the SE Manager	63
4.2.4 Access via the local console	64
4.3 Secure access to XenVMs on SU300	65
5 Remote service (AIS Connect)	66
5.1 Service account	67
5.2 Logging support operations	68
5.3 Using encryption	69
5.4 Using the "shadow terminal" function	70
5.5 Monitoring the current usage of the service access	71
5.6 Access to external assets	72
6 Configuration and diagnostic data	73
6.1 Configuration data backup	74
6.2 Diagnostic data	75
7 Network security	76
7.1 Network services	77
7.2 IP-based access restriction	79
7.3 Security at Net Unit level	80
7.4 Net-Storage	81
7.5 SNMP	82
8 Security of the base system	83
8.1 Hardening the base system	84
8.2 Software signature	85
8.3 Digital certificates	86
8.3.1 Confirming/importing a certificate in the web browser	87
8.3.2 Using the standard certificate	91
8.3.3 Creating and activating a new self-signed certificate	94
8.3.4 Requesting an SSL certificate	95
8.3.5 Uploading and activating a customer-specific certificate	97

8.4 Security fixes	99
9 Logging actions in the system (audit logging)	100
10 Event logging and alarm management	101
11 Related publications	103

Security Manual

1 Introduction

With the FUJITSU Server BS2000 SE Series (SE servers), FUJITSU offers a server infrastructure which consists of two server lines.

Depending on requirements, an SE server contains all the system components needed for operation as an overall application:

- Server Unit /390 for BS2000 guest systems
- Server Unit x86 with BS2000 guest systems, SU300 also with Linux or Windows guest systems as an option
- Application Units x86 for operating Native or hypervisor systems (e.g. Linux, Windows, VMware, OVM, etc.)
- Shareable tape and disk periphery
- A high-speed, server-internal infrastructure to connect the components with each other and with the customer's IP and FC networks.

The SE server offers the following advantages:

- Cross-system administration with state-of-the-art, browser-based GUI (SE Manager) as a single point of operation
- Centralized system monitoring of all components
- End-to-end redundancy concept
- Joint service process
- All options for consolidation through virtualization
- SE components and infrastructure are preconfigured and supplied to customers ready to use

SE servers consequently enable flexible and application-specific implementation which fulfills high SLAs through the use of high-end components and an end-to-end redundancy concept, and nevertheless permits cost-effective operation of the overall system with few resources thanks to its uniformity.

Intel x86-based server systems with their VMware, Linux or Windows system platforms also profit from the concepts for stable system operation tested on the mainframe:

- Selection of high-quality server components
- Redundant hardware components
- Prepared operating concepts which also include high availability
- Comprehensive tests before release
- Comprehensive service concept.

The management interface which is uniform for all SE servers, the SE Manager, permits a view of all the system components involved and, from this higher-level perspective, enables the resources to be optimized through efficient distribution of the application to the systems which are currently utilized least.

It is possible to combine two SE servers in a management cluster to a management entity and therefore utilize the advantages of the SE Manager for two SE servers at the same time. Every Management Unit can be used to control all components of the cluster, thus enhancing protection against failure. Within an SU Cluster, a live migration can be performed to migrate BS2000 systems without interruption.

SE servers consequently permit particularly stable system operation which includes not only the mainframe platforms which have to date been known to be particularly failsafe, but also other Server Units and the infrastructure and peripherals employed by the SE server. This can be achieved with fewer resources for administration and system operation than for separate operation of different IT systems.

The base systems of the Management Unit, HNC and Server Unit x86 (M2000, HNC and X2000) are systems which satisfy stringent security requirements. The statically implemented security of hardened systems is concerned here which is not significantly influenced by administration measures.

The base systems of these units (M2000, HNC and X2000), which are based on SUSE Linux Enterprise Server (SLES) 11, can be described as hardened for the following reasons:

- Only signed software components which are absolutely essential for operation are installed.
- Nonprivileged accounts are used for administration and operator access. These are equipped with clearly defined (and restricted) functions and access rights as part of a differentiated role strategy. No access to the system is possible outside this role strategy. Rights cannot be escalated; access to the `root` account is locked.
- The role and user strategies enable personalized accounts to be configured and passwords and password attributes to be managed.
- The data traffic between the administration PC and Management Unit, HNC and Server Unit x86 is encrypted.
- All ports which are not used are closed.
Services are started only when they are actually used.

The configuration of the base systems is based on the recommendations of the Center for Internet Security (CIS, <http://www.cisecurity.org>). Deviations from these recommendations result only from the functions required for operation. These deviations do not, however, lead to security holes.

This Security Manual describes mainly the security and hardening measures at the level of the base operating system M2000 of the externally accessible Management Unit on the basis of the functions of the operating and service strategy. HNC and Server Unit x86 are protected to the outside and are therefore not described in detail. Where necessary, differences that need to be taken into account for the Application Units are examined.

i In the few cases in which administration measures affect the security of the system, information and instructions on correct handling are provided under the heading **Security-relevant aspects**.

Security-relevant aspects of BS2000 or other operating systems and applications which are operated using the systems are not examined.

1.1 Objective and target groups of this manual

This manual is intended for security officers and administrators of an SE server. Knowledge is required of the BS2000, Linux and, where appropriate, Windows operating systems. Basic knowledge of how to operate graphical interfaces is also an advantage.

1.2 Summary of contents

The manual contains the security-relevant information for the SE server. The systems Management Unit, HNC, Server Unit x86 and Application Units on the SE server are examined individually.

The Application Units have a special position. Compared to the Management Unit, HNC and Server Unit, in the Application Units the user plays a greater role in administration and monitoring. The information in this manual therefore applies generally only for the Management Unit, HNC and Server Unit x86. When information also applies for Application Units, this is stated specifically.

The Management Unit, HNC and Server Unit x86 are systems that have been specially configured and hardened by FUJITSU.

By contrast, the operating system which is optionally preinstalled on an Application Unit contains no special security provisions. Here the user bears sole responsibility for configuring a secure system.

On the other hand the Management Unit, HNC and Server Unit x86 differ in their functionality, which means that some of the information in this manual is only applicable for some of these systems. In this case the systems concerned are named at the start of the section (in the heading or in the introductory sentence).

The various chapters of the manual deal with the topics which are relevant to security.

The operation and administration of the SE server are described in detail in the "Operation and Administration" manual [2] and in the context-sensitive online help of the SE Manager. There you will also find further information on operating the functions dealt with in this Security Manual.

Information on security in BS2000 OSD/BC is provided in the "Introduction to System Administration" manual [8] and the manuals for the software product SECOS [9 and 10].

README file

Information under BS2000

When a Readme file exists for a product version, you will find the following file on the BS2000 system:

```
SYSRME.<product>.<version>.<lang>
```

This file contains brief information on the Readme file in English or German (<lang>=E/D). You can view this information on screen using the `/SHOW-FILE` command or an editor. The `/SHOW-INSTALLATION-PATH INSTALLATION-UNIT=<product>` command shows the user ID under which the product's files are stored.

Additional product information

Current information, version and hardware dependencies and instructions for installing and using a product version are contained in the associated Release Notice. These Release Notices are available online at <http://bs2manuals.ts.fujitsu.com>.

1.3 Changes to the predecessor manual

This manual describes the functionality of the SE Manager with the use of the basic software M2000/X2000/HNC V6.3A.

Information on the hardware lifecycle of the FUJITSU Server BS2000 SE Series



With the hardware lifecycle of the SE Series, the hardware basis for the Server Unit x86, the Management Unit and the HNC has been renewed several times. If the following generations are not identified by their own designations (e.g. SU300 SU300B SU310), the generations are identified by a subsequent Mx with x = 1,2,3,...: MU M2, MU M3, HNC M2, HNC M3 etc. The generation M2 is supported as of SE V6.2A, the generation M3 as of version 6.3 A04.

Functional extensions

The functional extensions when using the basic software M2000/X2000/HNC V6.3A are described in the user guide „Administration and Operation“ [2].

1.4 Notational conventions

The following **notational conventions** are used in this manual:

	This symbol indicates important information and tips which you should bear in mind, in particular the section Security-relevant actions .
	This symbol and the word CAUTION! precede warning information, which in interests of system and operating security you should always observe this information.
>	The action which you must perform is indicated by this symbol.
<i>italics</i>	Texts from the SE Manager
monospace	System inputs and outputs
<abc>	Variables which are replaced by values.
Key symbols	Keys are displayed as they appear on the keyboard. When uppercase letters need to be entered, the Shift key is specified, e.g. SHIFT - A for A. If two keys need to be pressed at the same time, this is indicated by a hyphen between the key symbols.
[number]	The titles of related publications in the text are abbreviated. The complete title of each publication which is referred to by a number is listed in the Related Publications chapter after the associated number.

Names and abbreviations

In this manual, abbreviations are used to describe the SE server models and their components. These are explained in the introduction to the Basic Operating Manual [3] in the section "Models, Names, Abbreviations".

2 Architecture of the SE servers and networks

The description is divided into the following sections:

- Hardware
- Architecture of SE servers
- Networks
- Cluster

2.1 Hardware

In the maximum configuration, a FUJITSU Server BS2000 of the SE Series (SE server for short) consists of the following components:

- Management Unit (MU) with SE Manager
The operation of the SE server with a single Management Unit is called a "single-MU configuration". The Management Unit can be redundant in design. An SE server configuration with more than one Management Unit (MU redundancy on the SE server or Management Cluster with two SE servers) is called "multi-MU configuration".
MU redundancy ensures that the components of the SE server can still be operated if one MU fails. In particular this means that the SKP functionality is then still available for operating an SU /390.

- Server Unit (SU)
 - An SU /390 enables operation of BS2000 (Native BS2000 or VM2000).
 - An SU x86 enables operation of BS2000 (Native BS2000 or VM2000). XenVM operation with Linux or Windows guest systems is also possible as an option on SU300.

Depending on the model family, the following combinations are possible:

- SE710 with an SU /390
- SE700 with an SU /390 and optionally up to two further SU x86
- SE500 with an SU /390 and optionally up to two further SU x86
- SE310 with an SU x86
- SE300 with an SU x86 and optionally up to two further SU x86
- Application Unit (AU)
Multiple AUs can be operated on the SE server. An AU enables operation of applications under Linux, Windows or hypervisor-based systems.
- Net Unit (NU)
The Net Unit offers maximum performance and security for internal communication in an SE server and for a connection to customer networks (IP networks). For an SU /390, an HNC is an additional component of the Net Unit.
In the case of SE /390 the Net Unit is always redundant in design. In the case of SE x86 redundancy of the Net Unit is optional.
The Net Unit is supplied preconfigured, is autonomous with respect to SE server management, and can easily be connected to the customer network.
- Rack console and KVM switch
- Peripherals (storage)
- Optional hardware components:
Disk storage systems (for SU x86, AU), tape library systems (for SU x86), FC switches

2.2 Architecture of SE servers

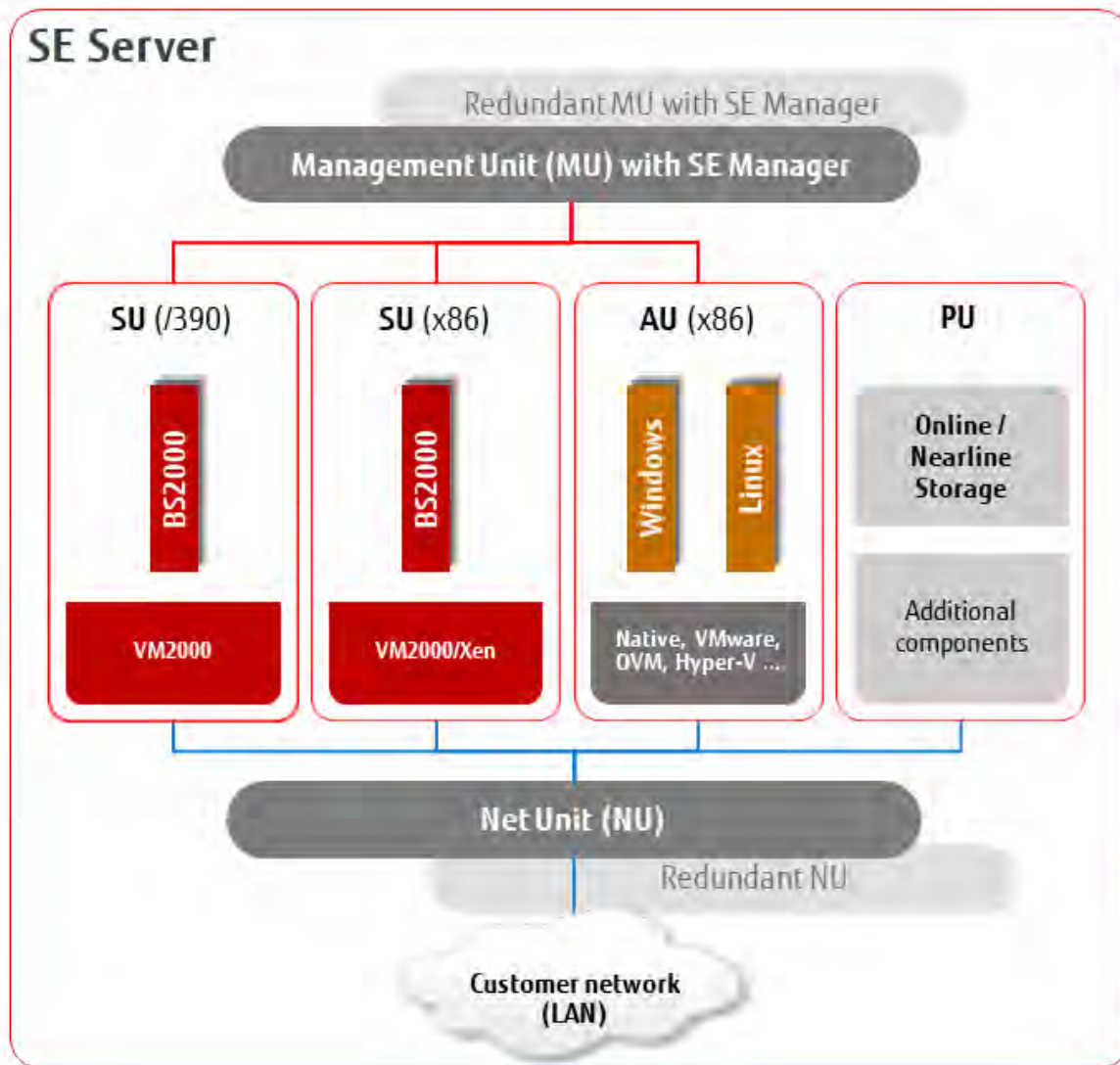

Figure 1: Architecture of SE servers

The SE Manager of each MU enables you to operate and manage all components of the SE server centrally. The SE Manager offers a user-friendly, web-based user interface for this purpose.

The Net Unit offers maximum performance and security for internal communication in an SE server and for a connection to customer networks (IP networks).

i Security-relevant actions

The following settings and measures, which are relevant to security, must only be implemented on one MU of the SE server configuration:

- You can configure user accounts and assign individual authorizations for operator accounts. See [section "Role strategy and user accounts"](#).
- To use centrally managed accounts (LDAP accounts), you have to set up and configure an LDAP access, see [section "Configuring access to an LDAP server"](#)

The following settings and measures, which are relevant to security, must be implemented on each MU of the SE server configuration:

- You must define the configuration of the IP addresses and networks in the same way for both MUs, see [chapter "Network security"](#).
- You must define the security settings for service access on each MU, see [section "Using the "shadow terminal" function"](#) and [section "Access to external assets"](#).
- At each MU where you call the SE Manager, you must confirm or import the certificate of this MU, see [section "Digital certificates"](#).

2.3 Networks

The Net Unit implements the connection of the units to the networks of the SE server and to customer networks. In addition, private networks are available for internal communication in the SE server.

The following logical networks are supported:

- Public management networks
 - Management Admin Network Public (MANPU)
 - Management Optional Admin Network Public (MONPU): the additive administration network can be configured when required (e.g. when AIS Connect is not to be operated via MANPU).
- Management Network Private
 - Management Control Network Private (MCNPR) for SE server communication
 - Management Optional Network Private (MONPR): when required, up to 8 additive networks MONPR<n> (where <n>= 01..08) can be configured for SE server communication.
 - Management Control Network Local (MCNLO) for the local SE server communication
 - Management SVP Network Private (MSNPR) enables SVP communication to the SU /390 on SE700/SE500
- Data Network Public
 - Data Network Public (DANPU): when required, up to 8 additive networks DANPU<n> (where <n>= 01..08) can be configured for connecting applications to the public customer network.
- Data Network Private
 - Data Network Private (DANPR): when required, up to 99 networks DANPR<n> (where <n>= 01..99) can be configured for internal private customer networks for SE servers.

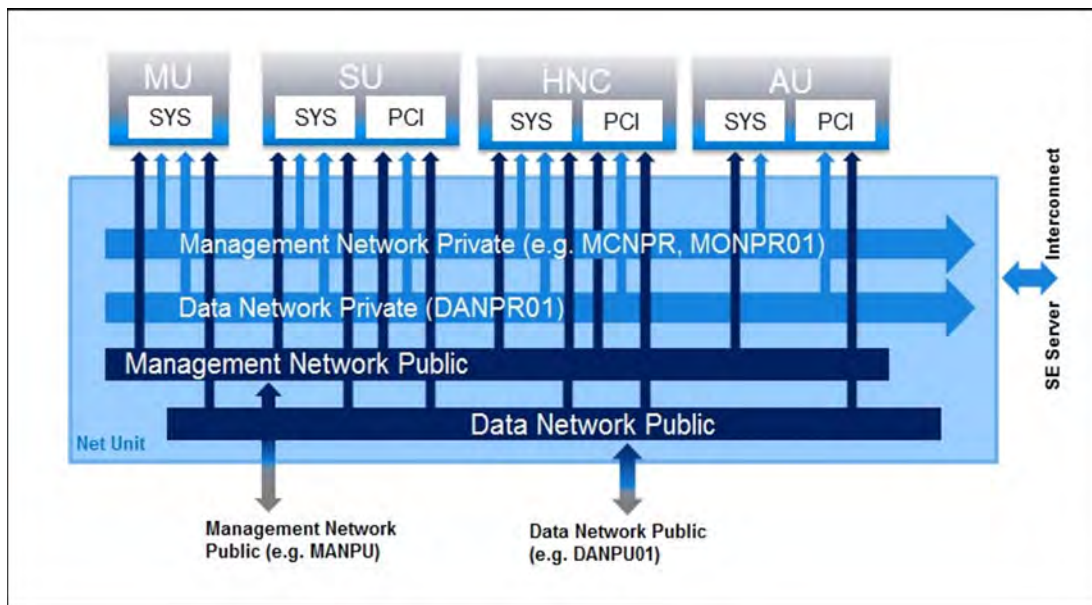

Figure 2: Block diagram of the Net Unit

The use of different networks means that components of one network cannot influence the other network, in other words the networks are protected from each other.

Furthermore, by means of ACL services (TCP/UDP ports) of the DANPU<xx>, MANPU, MONPU, DANPR<xx> and MONPR<xx> networks can be restricted in the Net Unit configuration (see [section "Security at Net Unit level"](#)).

The base operating system of the HNC and SU x86 can only be reached over the internal networks and are thus protected from the customer networks.

i **Exception:** This does not apply if Net-Storage with connection to MANPU or DANPU is configured on HNC or SU x86!

With a suitable firewall setting on HNC or SU x86, you can ensure that only the port required for communication (via NFS v3 or v4) with the Net-Storage is accessible.

In addition to the connections of the units to the switches of the Net Unit (for use by the guest systems), direct cabling from the units to the customer network can also be used.

2.4 Cluster

Two types of clusters are possible in an SE server configuration.

Management Cluster

If two SE servers are combined into one management entity, it is called a "Management Cluster" (or "SE Cluster").

A Management Cluster is configured by Customer Support based on the customer's wishes and is used to operate and administrate the two SE servers together.

A Net Unit connection between the two SE servers (ISL-E) and one or two external configuration disks for managing the global data are required to establish a Management Cluster.

Regarding administration and operation, all MUs of the Management Cluster are equally ranking. This means you can centrally administer and operate all objects of the whole SE server configuration (in this case: two SE servers) from one MU.

The SE servers can be operated as long as one MU functions. However, an MU of the local SE server is required for the SVP operation of an SU /390 and its correct HW display.

SU Cluster

Two Server Units of the same type (SU /390 or SU x86) can be combined into a logical unit, a so-called "SU Cluster".

An SU Cluster is configured by Customer Support based on the customer's wishes and provides the Live Migration (LM) function for the BS2000 systems of the two Server Units.

An SU Cluster with SU /390 is always cross-server and thus requires a Management Cluster. An SU Cluster with SU x86 may also be configured locally on one server, in case an SE server has more than one SU x86.

For further information on cluster types and the Live Migration function, see the "Operation and Administration" manual [2]. For further information on using clusters, see the "Cluster Solutions for SE Servers" whitepaper [7].

3 Secure access to management functions

The description is divided into the following sections:

- Role strategy and user accounts
 - Role strategy and role authorizations
 - User accounts
 - Centrally managed accounts (LDAP accounts)
 - Authorization for account management
 - Further accounts of the base system
 - Accounts for add-on packs
 - Authentication
 - Password administration for local accounts
 - Configuring access to an LDAP server
- Access to the SE Manager
 - Security settings on the administration PC
 - Communication with encryption
 - Session management
- Text-based access (at shell level)
 - Encrypted communication with Secure Shell
 - No rights escalation
 - Access functions in the SE Manager
- Alternative accesses with Secure Shell
 - Secure Shell host key
 - Communication using Secure Shell keys
 - Generating the keys
 - Using SSH agents
 - PuTTY with PuTTYgen and Pageant
 - Key generator PuTTYgen
 - Authentication agent Pageant
- Access via the local console
- Access to the iRMC of the Management Unit
- Protected access to the BIOS and the bootloader

3.1 Role strategy and user accounts

Accounts and authorizations work globally, i.e. cross-MU. In a multi-MU configuration, each action has to be performed once and on one MU only.

In the case of a Management Cluster, each role or account is valid for the whole cluster.

3.1.1 Role strategy and role authorizations

One major part of the security strategy is the role strategy which incorporates the following features:

- The roles are graduated:
Only the necessary interfaces and functions are available to each role.
- Each user account is permanently assigned to a role.
- No rights escalation is possible, i.e. no access (or transition) is possible to interfaces and functions other than those envisaged. In particular, no access is possible to the `root` account of the base operating system.

- Roles

The following roles are defined for users:

- Administrator
- BS2000 administrator
- Operator
- XenVM administrator
- AU administrator
- Service

The administrator role is higher ranking than the BS2000 administrator, operator, XenVM administrator and AU administrator roles and is authorized to execute all functions of the SE Manager and of the recommended CLI.

The service role is reserved exclusively for Customer Support.

The BS2000 administrator, operator, XenVM administrator and AU administrator roles have restricted rights which are tailored to their different task areas:

- A BS2000 administrator only has the authorization for functions of the SE Manager which are necessary to operate BS2000 systems. In addition, he/she also has some administrator authorizations: switching the units SU, MU and HNC on/off, performing a CSR backup, creating diagnostic data, accessing the shadow terminal, read access to the hardware inventory, and configuration of scheduled power on/off of the units SU, MU and HNC.
- An operator only has the authorization for functions of the SE Manager which are necessary to operate BS2000 systems. The administrator can also configure specific authorizations individually for an operator account.
- A XenVM administrator only has the authorization for functions of the SE Manager which are necessary to operate XenVM systems.
- An AU administrator only has the authorization for functions of the SE Manager which are necessary to operate the systems on AUs. In addition, he/she also has some administrator authorizations: switching the AUs on/off, read access to the hardware inventory, and configuration of scheduled power on/off of the AUs.

Overviews of the role-specific tasks and functions are provided in the “Operation and Administration” manual [2] and in the online help.

- Individual rights

The administrator can grant and deny rights for certain functions of the SE Manager to an operator account. A distinction is made here between server-related and system-related rights.

The authorizations below are server-related rights:

- *On/Off*
Displays whether the operator has the right to power Units on/off (*Granted* or *Denied*).
If the right exists, the operator can power all units which are displayed in the unit overview on or off in an emergency.
- *Shadow*
Shows whether the operator is entitled to access the shadow terminal (access *Granted* or *Denied* to the Customer Support staff).
- *SVP*
Only on SE servers with SU /390:
Shows whether the operator has the SVP right (e.g. IPL and shutdown *Granted* or *Denied*).

The rights below are system-related rights:

- *Unit*
Unit for which system-related rights, more precisely console rights, are assigned. The access rights to BS2000 systems of an SU /390 are entered for the Management Unit, the BCAM name of the SU /390 being displayed after them in parentheses. The access rights to BS2000 systems of an SU x86 are entered for the SU x86 concerned.
- *Console rights*
Shows the systems for which the operator has console access authorization. The permitted systems are entered explicitly with KVP and console MN.
- *Dialog*
Shows whether the operator has the right for BS2000 dialog access (access *Granted* or *Denied*). This right can only be assigned if at least one console right is entered.

i Security-relevant actions An operator can release or lock the following functions of the SE Manager for operating (see main menu *Authorizations* -> *Users* -> *Individual rights*):

- Powering on/off units
- Access to a shadow terminal
- Access to the SVP (SE Server with SU /390 only)
- Access to a BS2000 console on a particular BS2000 system
- Access to the BS2000 dialog on a particular BS2000 system

When two SUs form an SU cluster, a Live Migration (LM) of BS2000 systems from one SU to another is possible. For BS2000 systems, the individual authorizations for accessing the BS2000 dialog and the BS2000 console should be identical on each SU of the SU cluster. If not, the originally intended access rights will change when a BS2000 system is migrated!

3.1.2 User accounts

(User) Accounts are assigned unambiguously to the roles and usages.

The accounts have the following role-specific features:

Administration

- There is the predefined, undeletable local administrator account `admin`.
- Any number of additional administrator accounts can be created. These accounts can be deleted again.
- In terms of their functional scope, all administrator accounts are equal.

BS2000 administration

- Any number of BS2000 administrator accounts can be created. These accounts can be deleted again.
- In terms of their functional scope, all BS2000 administrator accounts are equal ranking.

Operating

- Any number of operator accounts can be created. These accounts can be deleted again.
- In terms of their functional scope, all newly configured operator accounts are initially equal ranking. The functional scope can be enhanced individually by assigning individual rights.

XenVM administration

- Any number of XenVM administrator accounts can be created. These accounts can be deleted again.
- In terms of their functional scope, all XenVM administrator accounts are equal ranking.

AU administration

- Any number of AU administrator accounts can be created. These accounts can be deleted again.
- In terms of their functional scope, all AU administrator accounts are equal ranking.

Service

- There is a predefined, undeletable and unchangeable service account `service`. See also [section "Further accounts of the base system"](#).

3.1.2.1 Centrally managed accounts (LDAP accounts)

In addition to local accounts, the administrator can also permit LDAP accounts for the various roles. These accounts are managed centrally on an LDAP server (in particular also the passwords).

In order to use LDAP accounts, the access to an LDAP server must be configured. In the Management Cluster, access to the LDAP server can be configured specifically for one SE server. See [section "Configuring access to an LDAP server"](#). When this requirement is satisfied, the administrator, when creating an account, can release an LDAP account by means of the account type for the desired role. The simultaneous use of a central and a local identifier of the same name is not possible. When an LDAP account is removed, the access of this account is also locked again.

3.1.2.2 Authorization for account management

Other accounts (irrespective of their type) can only be managed under an administrator account. Specifically, this concerns the following functions:

- Create account (or release LDAP account)
- Delete account (or lock LDAP account)
- Managing the password and password attributes for local accounts

i Security-relevant actions

- There is an initial default password for the pre-defined account `admin`, which you can obtain from Customer Support.

Change the password immediately after you have logged in for the first time. You may also change the validity time and the other password attributes.

You can access the password management as follows:

- in SE Manager: *Authorizations -> Users -> Password management*
- on the iRMC: *User management -> iRMC S4 users*
- New accounts which are created should be “personalized”.
This enables the assignment of an account to a person to be recognized immediately from the name.
- When you create an account, you assign a password which must be 6-20 characters in length.

3.1.2.3 Further accounts of the base system

The following accounts are reserved for Customer Support:

- `service`

The `service` account is used by Customer Support (locally and by means of remote service) as an access and diagnostics account.

i The `service` account (account with the Service role) is displayed in user management, but it is not subject to account management by the administrator.
The following accounts of the base system are not displayed in the user management and are not subject to account management by the administrator.

- `tele`

The `tele` account is used by Customer Support as an access account and by the user to operate the shadow terminal. There is no other functionality available under this account.

- `root` and `vroot`

The `root` account is locked. The `vroot` account is a virtual account without a shell and without a home directory. It is reserved exclusively for the Support Center to permit the rights of the `service` account to be escalated (extended) further than envisaged.

The following accounts which are also required internally but which are not visible to the user and locked for login also exist:

- `x2kinternal`, and the AIS account `c2suxadm`.
- `storman` when the add-on pack StorMan is installed.
- `opensm2` when the add-on pack openSM2 is installed.
- `openutm` when the add-on pack openUTM is installed.
- `robar` when the add-on pack ROBAR-SV is installed.

3.1.2.4 Accounts for add-on packs

The following is generally applicable for add-on packs:

- Add-ons have as a rule their own user and role management. This user and role management is retained.
- Accounts in add-ons are always MU local (as are the add-on packs themselves). Since they do not correspond to a role in the SE Manager, they are not displayed in the SE Manager.
- Accounts in add-ons become effective only when they are also defined as accounts in the SE Manager.

In the SE Manager no explicit rights are assigned for individual add-ons. The call rights for add-ons are derived implicitly from the role of the user account with which the user is logged in on the SE Manager and can be changed within the add-on pack in accordance with the user and role concept.

3.1.3 Authentication

Access to the SE Manager of an MU is only possible by means of authentication using an account and password.

For accounts, the password stored in the `/etc/shadow` file is checked for authentication purposes.

A permanently specified PAM configuration (PAM = Pluggable Authentication Modules) is used for authentication purposes. The PAM configuration is used in the following cases:

- SSH login at shell level
- Login on the web interface
- Login on the Gnome desktop of the local console

Passwords are hidden during entry (they are displayed as dots) and can consequently not be read by unauthorized persons.

If the login fails in the SE Manager, you can only log in again after a wait time of 10 seconds. This wait time protects against automated trial and error attacks.

3.1.4 Password administration for local accounts

The passwords of the local accounts have the following attributes:

Validity time, Warning time, Minimum time, Inactivity time

- During the Validity time, which applies from the last time the password was set, it is possible to log in without restriction.
- During the minimum time, a non-administrator cannot change his/her own password.
- During the warning time, a warning is issued that the password will soon no longer be valid. However, it is possible to log in without restrictions.
- During the inactivity time, the password is no longer valid, but it is still possible to log in. Directly after a user has logged in, a request to change the password is issued.
- After the inactivity time has elapsed, the account is locked. It can be opened again from an(other) administration account or, if necessary, by Customer Support.
- The value -1 for the *Inactivity time* results in the inactivity time not elapsing.
- The value 99999 for the *Validity time* means, in practice, that you need not change the password.

The figure below shows the relationship between these times.

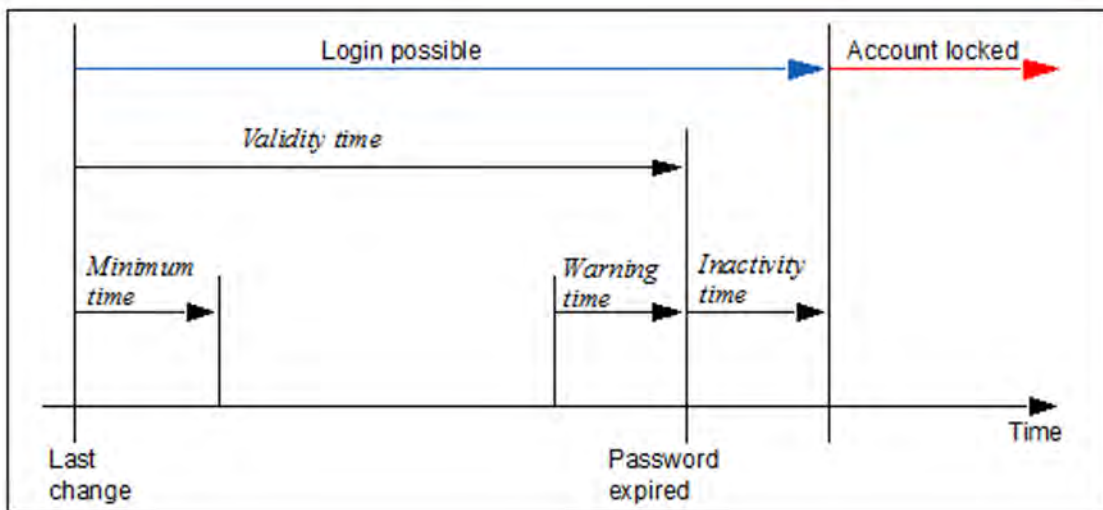

On the basis of the settings for system hardening, customer accounts are created with the following default values for password administration:

- Validity time of the password: 60 days
- Minimum time before the password is changed again: 7 days
The minimum time is irrelevant for the administrator account and is not displayed.
- Warning time before the password expires: 7 days
- Inactivity time after the password expires: 7 days

Every administrator can change individual password administration settings of an account at any time. A non-administrator can only change the password of his/her own account. However, this is only possible if the minimum time has elapsed.

When you log in on the web interface, the following situations can occur with regard to the password status and password administration depending on your role:

- If the current account is in the warning time, this is shown by a warning icon in the title bar of the main window:

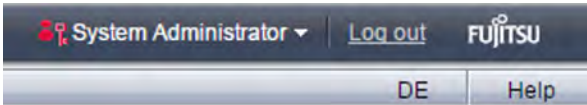

In addition, a tool tip shows the user after how many days his/her password will expire.

- If an account is in the inactive time, it is still possible to log in, but a change of password is forced immediately in the login window.

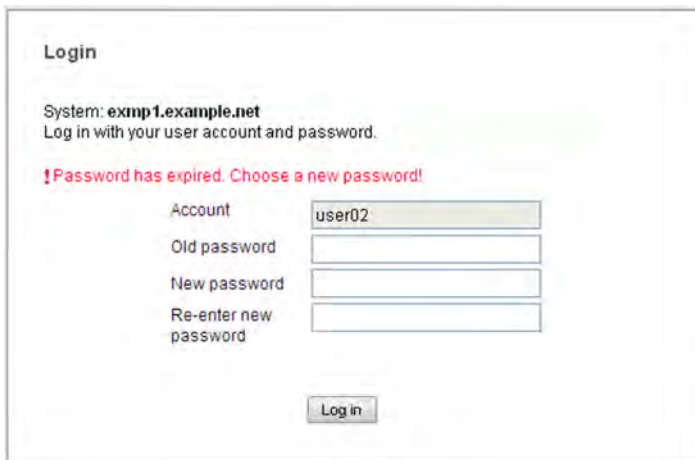
The image shows a 'Login' window for the system 'exmp1.example.net'. It prompts the user to log in with their user account and password. A red warning message states: 'Password has expired. Choose a new password!'. Below this, there are four input fields: 'Account' (containing 'user02'), 'Old password', 'New password', and 'Re-enter new password'. A 'Log in' button is located at the bottom of the form.

- If the inactivity time has elapsed, the account is locked and it is no longer possible to log in. Intervention by an (other) administrator or Customer Support is then required (see "[Security-relevant actions](#)").

At shell level, the familiar behavior on Linux systems applies when logging in:

- During the warning time a warning is issued in the course of the login, e.g.:
Your password will expire in 2 days.

! **Attention!**
The `passwd` command must not be used at the shell level!

In this situation, the user should log in on the SE Manager and change the password even before the warning time expires.

- During the inactivity time a change of password is forced in the course of the login.

In this situation, the user must act as follows:

1. Abort the log in to the shell.
 2. Log in on the SE Manager and change the password in the login window.
 3. Repeat the log in to the shell.
- If the inactivity time has elapsed, the account is locked and it is no longer possible to log in. The login fails without any reason being given.

i Security-relevant actions

- The administrator can adjust the settings for password administration so that they comply with the security policy in the data center.
The settings can only be changed for individual accounts and not globally for all accounts on the system.
- Each user is requested to maintain his/her password in accordance with the security policy in his/her data center.
- It can occur that an account is locked because the inactivity time was exceeded. In this case an(other) administrator can cancel the lock for this account for exactly one login. The *Enforce password change* function (see online help) is used for this purpose.
- Customer Support is always able to cancel a lock for an account.

3.1.5 Configuring access to an LDAP server

The *LDAP* tab in the *Authorizations -> Configuration* menu enables you to configure and edit the access to an LDAP server on which the LDAP accounts are managed that can be released for the MUs of the SE server.

i In a Management Cluster, you can configure one LDAP server per SE server. Two redundant MUs in one SE server share the same LDAP server.

The LDAP server and the MU(s) must synchronize their time via the same NTP server.

In a Management Cluster, the configurations for each SE server are displayed in individual groups. The LDAP configuration is SE server-specific, but in the default mode it is configured for both SE servers together (i.e. both get the same configuration). For more information on the LDAP configuration in the Management Cluster, see the "Cluster Solutions for SE Servers" whitepaper [7].

i Security-relevant actions

As administrator you can configure and edit the access to an LDAP server. For access, you need a valid account on an LDAP server (Bind DN) with a password.

- When you enter or change the access data, you can test if the LDAP server configuration works correctly. You can only work with LDAP accounts if the test was successful.
- As soon as you activate the access and a connection to the LDAP server is established, the released LDAP accounts can be used to log in on the SE Manager.
- As soon as you de-activate the access, the released LDAP accounts can no longer be used.
- As soon as you delete the LDAP configurations, the configuration data are removed and the LDAP accounts can no longer be used to log in on the SE Manager. The valid accounts on an LDAP server still exist.

3.2 Access to the SE Manager

The description is divided into the following sections:

- Security settings on the administration PC
- Communication with encryption
- Session management

3.2.1 Security settings on the administration PC

The software requirements for the administration PC are described in the "Operation and Administration" manual [2] and in the online help. Of these requirements, the following points are relevant to security:

- **The execution of JavaScript in the web browser is both possible and permissible.**
If the execution of JavaScript is not permitted on the administration PC, the SE Manager cannot be used.

- **Cookies are permitted in the web browser.**
If no cookies are permitted on the administration PC, the SE Manager cannot be used.

The SE Manager generates and uses a number of cookies:

- One cookie is used to manage the session.
- Another cookie stores - on a cross-session basis - the language setting selected explicitly by the user in the SE Manager.
- In addition, further temporary cookies are used to manage current settings (e.g. whether the tree structure is expanded or collapsed) or for other technical purposes (e.g. for variable object lists in the tree structure).

i Security-relevant actions

- Depending on the configuration, web browsers offer the *Store password* function. You are recommended not to use this function because then a *Show password* function which displays passwords in plain text is as a rule also available.

3.2.2 Communication with encryption

HTTPS (HyperText Transfer Protocol Secure) is always used for communication, whereby encryption protocols SSL 3.0 (Secure Sockets Layer) and TLS 1.3 (Transport Layer Security) beneath HTTPS are supported. TLS 1.1 is used for the internal communication with administered AUs.

Automatic redirection to HTTPS takes place for HTTP calls. This applies both for external communication between the administration PC and one of the systems Server Unit, Management Unit or HNC, and also for internal communication of these systems with each other.

3.2.3 Session management

The SE Manager of the system concerned is protected against unauthorized access both by authentication and by session management.

Following the login, one session whose validity is constantly monitored is set up for each client (browser instance of the calling web browser) and system.

In the *Authorizations* -> *Users* menu the *Sessions* tab informs the administrator about all sessions of users which are currently logged in on the SE Manager. In addition to the information on the user and IP address of the PC, the current individual setting for the session is also displayed.

A session ends in the following cases:

- Explicitly because of *Log out* in the header area of the main window
- Because of a session timeout (default: after 20 minutes of inactivity on the SE Manager)

In both cases you are shown the login page to permit you to log in again, immediately in the case of *Log out* and, if the session timed out, with the first action that occurs after the session timeout.

Windows in which terminals are opened are not subject to session management. This guarantees interrupt-free usage of the following additional functions:

- Accesses to the BS2000 console and BS2000 dialog
- Access to the XenVM console
- Access to the CLI (shell)
- Access to the shadow terminal (Remote Service)
- Access to the SVP console of the SU /390

i Security-relevant actions

- Each user can change the setting for the session timeout for himself/herself personally:
 - > Click in the login information in the header area. A list containing the menu item *Individual settings* opens.
 - > Click *Individual settings*. The *Change update cycle and session timeout* dialog box opens in which you can enable/disable the session timeout and set the timeout in the range from 5 to 60 minutes.

The individual setting is stored on a browser-specific basis.

In addition to the lock for the administration PC, the following protective measures are also recommended when you leave your workstation:

- Explicit logout from the SE Manager.
- Close all windows which have a terminal loaded.
If the application has its own lock mechanism (e.g. the console monitors), the window can stay open and the lock mechanism provided can be used.

3.3 Text-based access (at shell level)

The description is divided into the following sections:

- Encrypted communication with Secure Shell
- No rights escalation
- Access functions in the SE Manager

3.3.1 Encrypted communication with Secure Shell

Communication is always encrypted and the SSH protocol is used.

This applies for both internal communication (e.g. for the connections to BS2000 consoles on the SU x86) and for external communication (e.g. between the SSH client and the system).

3.3.2 No rights escalation

No rights escalation is possible in the base operating system using the Linux command `su`.

3.3.3 Access functions in the SE Manager

When the functions below are called, a terminal which is integrated into the SE Manager is loaded into a separate window:

- Accesses to the BS2000 console and BS2000 dialog
- Access to the CLI with execution rights for a restricted set of CLI commands (see "CLI command reference" in the online help under *Further information -> PDF documents*)
- Shadow terminal (on the *Remote Service* tab)
- Access to the SVP of the SU /390

3.4 Alternative accesses with Secure Shell

For communication at shell level, as an alternative to the terminal integrated into the SE Manager you can use the SSH client PuTTY (Version 0.63 and higher). See [section "Alternative access to the BS2000 operating system with PuTTY"](#).

The examples below refer to the SSH client PuTTY.

3.4.1 Secure Shell host key

During system installation, a host key is created on the system.

The first time a connection is set up, you must confirm this host key (depending on the SSH client) as in the following example with PuTTY.

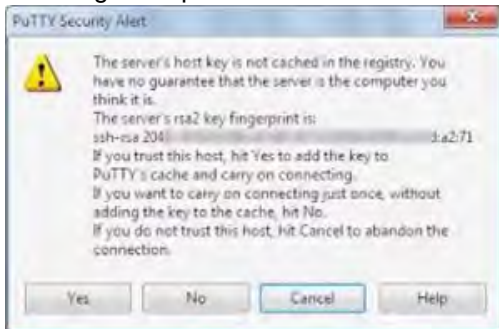

3.4.2 Communication using Secure Shell keys

SSH authentication is possible not only using an account and password, but also by means of an SSH key pair.

This type of authentication should be preferred above all when programming automated procedures because a password then does not need to be coded in plain text.

i Security-relevant actions

As administrator you can store SSH key (pairs).

You can provide additional protection for the stored keys by means of “passphrases”.
The key management associated with this is described in detail in the next section.

3.4.3 Generating the keys

In SSH authentication and encryption are based on the asymmetrical system of public and private keys. Encryption and decryption are performed using different keys. Thereby it is not possible to derive the key for decryption from that used for encryption. For this purpose the user generates a key pair consisting of one public and one private key. The public key is intended for forwarding to other users, whereas the private key is not forwarded by the user.

The two keys are used as follows:

Authentication

- When a user logs in on a remote system, this system generates a random number, encrypts it using the user's public key and returns it to the local system. The appropriate private key is required to decrypt this coded random number; the decrypted data is now sent back to the remote system, where it is checked, thereby the owner of this private key authenticates himself/herself.
- The private key enables signatures to be generated (e.g. for a digital signature). A signature generated with a private key cannot be copied by anyone who does not have this key.

Everybody who has the associated public key can verify whether a signature is genuine.

Encryption

- The public key can also be used to encrypt a message to someone who has the associated private key.
- Only someone who has the associated private key can decrypt such a message.

As the public key is only used to encrypt a message, not too much care must be taken to ensure that it does not fall into the wrong hands (in contrast to the private key).

Generating the keys

Various algorithms are available for generating such key pairs, the best known being RSA and DSA. Under Linux they are generated by calling the `ssh-keygen` command (see <http://www.openssh.com>). Only Version 2 RSA keys can be used. The minimum key length is 512 bits. In general, 1024 bits are considered sufficient. The keys generated are stored in the local file system:

The RSA authentication identity is stored in the `$HOME/.ssh/id_rsa` file and the public RSA key in the `$HOME/.ssh/id_rsa.pub` file.

The DSA authentication identity is stored in the `$HOME/.ssh/id_dsa` file and the public DSA key in the `$HOME/.ssh/id_dsa.pub` file.

The key pairs can also be generated using a GUI-based tool. In this context the PuTTY key generator is described in the [section "PuTTY with PuTTYgen and Pageant"](#).

Distributing the public keys to communication partners

In the next configuration step the user must enter the public key in the `$HOME/.ssh/authorized_keys` file on all remote systems with which he/she wishes to communicate. This can be done, for instance, by copying the local identity file for the public key to the remote systems and appending its content to the `$HOME/.ssh/authorized_keys` file there.

Passphrases

The private key may not fall into the wrong hands. A few separate protection mechanisms are provided in SSH to prevent this. The `ssh` program issues a warning if the local identity file can be read by anyone other than the owner. A passphrase can be specified when a key pair is generated. This passphrase is used to encrypt and decrypt the private key when writing to or reading from the identity file.

You are recommended to protect the private key with a passphrase.

A passphrase is an extension of the password. It can be a sequence of words, numbers, blanks, punctuation marks and other arbitrary characters. Good passphrases are 10 to 30 characters long and contain a sequence of uppercase and lowercase letters, numbers and non-alphanumeric characters which are not easy to guess.

Unlike a password, a passphrase is not transferred to a remote computer as part of the authentication procedure.

There is no way of recovering a lost passphrase. Once it has been lost, a new key pair must be generated and its public key must be distributed to the communication partners.

3.4.4 Using SSH agents

i The use of an SSH agents makes it unnecessary to type in the (normally long and complex) passphrase each time the `ssh` program is called.

In an initialization run for SSH the key pairs are generated, stored in the local files and distributed to the communications partners. The SSH agent is started at the beginning of an interactive session and at the start of a script by calling the `ssh-agent` command (see <http://www.openssh.com>). The necessary private keys are then transferred to it by means of `ssh-add`. The SSH agent maintains these private keys in encrypted form in the memory. For this decryption process it requires the passphrases, if any were specified.

From this point until the SSH agent is terminated, SSH clients contact the SSH agent automatically for all key-related operations. If a remote connection is to be set up by means of an `ssh` call, the local SSH agent and the remote `sshd` daemon automatically execute the required authentication procedure.

If a passphrase is used, it needs only be entered once. It is read from the current terminal by `ssh-add` if `ssh-add` was started from the terminal. If no terminal has been assigned to `ssh-add` but the `DISPLAY` and `SSH_ASKPASS` variables are set, the program specified by `SSH_ASKPASS` is executed and an X11 window for reading the passphrase opens. This is useful if `ssh-add` is called in a `.Xsession` or in a startup script.

Example

```
ssh-keygen -b 1024 -t rsa -C <comment> -N "<passphrase>"
# Generates a 1024 bit RSA key in SSH Version 2 protected by a passphrase
ssh-agent /bin/csh # The path to a shell or a shell script can be specified as an argument
ssh-add # By default loads all keys of the identity file
```

The environment variables which point to the SSH agent's socket must be set to permit the SSH client to communicate with the agent. The `ssh-agent` program supplies the information required for this purpose when it returns:

Example

```
# In SSH Version 2 Notation:
SSH2_AUTH_SOCKET=/tmp/ssh-JGK12327/agent.12327; export SSH2_AUTH_SOCKET;
SSH2_AGENT_PID=12328; export SSH2_AGENT_PID;
```

These output commands of the `ssh-agent` program can be executed by means of the `eval` command. Please note the reverse quotes (```) here:

```
eval `ssh-agent ...`
```

The `eval` command instructs the shell to execute the `ssh-agent` command and then to execute the commands generated by it. The shell variables `SSH2_AUTH_SOCKET` and `SSH2_AGENT_PID` are then available. After the `eval `ssh-agent`` command has been executed, the SSH agent's PID is output.

The `eval `ssh-agent`` command should be included in the `~/.bash_profile` file.

Shell scripts

If SSH shell scripts are to be used, the SSH agent can be installed, the correct environment can be set and the agent can be supplied with the necessary keys and passphrases in an initialization phase or in a startup script before the script is started with the `ssh` calls.

In addition, the SSH script must be instrumented in order to set these values in the environment variables. To do this, the output of the `ssh-agent` program must have been stored in an auxiliary file which is then executed in the script by means of the `dot` command.

Example

```
ssh-agent|head -2 > <auxfile> # Store environment in initialization phase
:
:
:
. <auxfile> # Set environment in script
```

3.4.5 PuTTY with PuTTYgen and Pageant

This section describes how key pairs are generated and how the public keys are distributed with the help of PuTTY (see <http://www.chiark.greenend.org.uk/~sgtatham/putty>). PuTTY is a free implementation of Telnet and Secure Shell for Win32 and Unix system-based platforms and is useful in interactive mode.

- Key generator PuTTYgen
- Authentication agent Pageant

3.4.5.1 Key generator PuTTYgen

The PuTTYgen (see <http://the.earth.li/~sgtatham/putty/latest/html/doc/Chapter8.html>) key generator generates pairs of private and public keys which can be used with PuTTY, PSCP and Plink, and also by PuTTY's authentication agent Pageant.

The general procedure for generating a new key pair using PuTTYgen is as follows:

- > Select the type of key (RSA for SSH Version 2, or DSA for SSH Version 2) and specify the key length.
- > Click *Generate* and during generation move the mouse pointer in the window area.

When the key has been generated, the layout of the window changes: the entire key is displayed and then the *Key fingerprint* box shows the fingerprint value, a short name for the generated key.

- > Enter a passphrase in the *Key passphrase* and *Confirm passphrase* boxes. If these boxes are left empty, the private key is stored in the file in unencrypted form. This should not occur without a cogent reason.
- > Click *Save private key*.

PuTTYgen then opens a dialog box to ask for the storage location.

- > Select a directory and a file name.

The file is stored in the format used by PuTTY (file name extension .ppk).

- > Click *Save public key*.

PuTTYgen then opens a dialog box to ask for the storage location.

- > Select a directory and a file name.

The public key does not necessarily need to be stored locally on disk. You can also copy it directly to PuTTY sessions which run on the remote servers concerned. Proceed as follows to do this:

- > Set up a connection to these servers by means of PuTTY.
- > Then switch to the `$HOME/.ssh` located there and open the `authorized_keys` file with an editor (if no public key exists there yet, one must first be generated).
- > Switch to the PuTTYgen window, select the entire text in the *Public key for pasting into authorized_keys file* box, and copy it to the clipboard.
- > Return to the PuTTY window and enter the data from the clipboard in the open file. Pay attention that all the data is contained in one line.
- > Save the file.

3.4.5.2 Authentication agent Pageant

PuTTY's authentication agent Pageant (see <http://the.earth.li/~sgtatham/putty/latest/html/doc/Chapter9.html>) keeps the decrypted private keys in the memory and, if required, generates signatures and handles the authentication procedure.

You list the keys stored by Pageant as follows:

- > Start the Pageant program.
- > Right-click the Pageant icon in the taskbar.

A menu opens.

- > Select *View Keys*.

Pageant's main window opens, which incorporates a list box containing all the private keys currently stored by Pageant.

If the required key is not yet included, enter it as follows:

- > Click *Add Key*.

Pageant then opens the dialog box *Select Private Key File*.

- > From this dialog box select the file which belongs to your private key and click *Open*.

Pageant then loads the private key into the memory. If the key is protected by a passphrase, Pageant requests this passphrase.

As soon as the key is loaded, it appears in the list box of the main Pageant window.

You can now start PuTTY and open an SSH connection to a system which accepts your key. PuTTY recognizes that Pageant is running, fetches the key automatically from Pageant, and uses it for authentication purposes. You can now open further PuTTY connections without having to type in the passphrase each time.

3.5 Access via the local console

Access to the local console and physical access to the system is as a rule already protected because various locks and restrictions apply when accessing the data center.

On the local console on the SE server (rack console) you can operate the console switch using a hot key and switch between the existing units of the types Management Unit, HNC, Server Unit x86 and Application Unit.

For Application Units, see the [section "Access via the local console"](#).

Access to the Management Unit with Linux desktop (Gnome desktop)

When you access the Management Unit via the local console, the user interface you obtain is a Linux desktop of the type Gnome.

You can log in under any account.

The functionality of the Gnome desktop is identical for all accounts.

The Firefox web browser is anchored in the *Computer* menu. You can use it to call the SE Manager (addressed, for instance, with *https://localhost*).

As with remote operation, further authentication must be provided for the SE Manager with the current account. After you have logged in successfully, the SE Manager offers the functionality for the user role which corresponds to the account.

Other functions of the desktop on the local console include functions for calling a terminal window, for locking the screen, for configuring the screen saver and the mouse, and for logging out.

i Security-relevant actions

- When you leave your workstation, at least the screen should be locked.
Caution: the screen contents survive beyond a logout and login.
- If you are absent from the workstation for a lengthy period, you are recommended to log out. The screen contents are then lost.
- In the event of inactivity, the screen saver locks the Gnome desktop.
The default timeout setting for the Gnome desktop is 10 minutes. You can adjust this setting to your requirements.

3.6 Access to the iRMC of the Management Unit

The iRMC of the Management Unit can be used optionally. It must be connected to the public management network MANPU to permit this.

Access to the iRMC is possible via the SE Manager:

In the *Hardware* -> *Units* -> [*<se-server>* ->] *<mu>* -> *Information* menu the *System* tab shows the field *iRMC address* with a link to the iRMC.

Via this link you can open the iRMC's web interface.

The predefined account `admin` is available to the administration on the iRMC.

The following functions are recommended for administration purposes:

- Powering the Management Unit on/off (*Power Management* -> *Power On/Off* from the iRMC's web interface) *Power On* enables the Management Unit to be started up remotely.
- Changing the local password (by command only)

i Security-relevant actions

- **User management**

- The SE server is delivered with an initial password for the pre-defined `admin` account, which you can obtain from Customer Support. At iRMC level `admin` has the operator privilege and the additional privilege of console redirection. No further configuration possibilities are available.
Change the password immediately after you have logged in for the first time!
This is possible with the M2000 command `rmcPasswdAdmin` which is executable under any administrator account.
- Further (personalized) accounts can be created by Customer Support on request. These should not, however, be equipped with higher privileges than the predefined account `admin`. However, since administrative activities are extremely rare on the iRMC of the Management Unit, there is no need for further accounts.

! CAUTION!

You are urgently recommended not to change the password of the `service` account or to delete this account. If you do, the serviceability of the iRMC is not guaranteed, and the serviceability of the Management Unit is consequently also impaired.

However, if such a measure is necessary, it must always be agreed on with the Support Center.

Nor may the function account `x2kinternal` be changed, otherwise the functionality of the SE Manager will be impaired.

- **Protection functions**

- You can log out from the iRMC's web interface by means of *Logout*. When you leave your workstation, this can be used as an alternative or in addition to the locking mechanisms of the administration PC.

3.7 Protected access to the BIOS and the bootloader

The BIOS of the Management Unit, HNC and Server Unit x86 is protected by a password which is known to Customer Support.

The bootloader GRUB (GRand Unified Bootloader) which is used by Linux is also protected by a password which is known by Customer Support.

i By default the rack console (local console) is attached to the Management Unit. When you switch over the console switch (see [section "Access via the local console"](#)), you can reach BIOS and GRUB from the HNC or SU x86 via the local console.

4 Secure access to systems

This chapter describes secure access to the BS2000 operating system on the Server Units, to systems on the Application Units, and to XenVMs on the SU x86.

- Secure access to BS2000 systems
 - Security in the BS2000 operating system
 - Downloading KVP logging files
 - Alternative access to the BS2000 operating system with PuTTY
- Secure access to systems on Application Units
 - Configuration changes
 - Access to the iRMC / Management Board of the Application Unit
 - Integration of Application Unit into the SE Manager
 - Access via the local console
- Secure access to XenVMs on SU300

4.1 Secure access to BS2000 systems

The description is divided into the following sections:

- Security in the BS2000 operating system
- Downloading KVP logging files
- Alternative access to the BS2000 operating system with PuTTY

4.1.1 Security in the BS2000 operating system

BS2000 OSD/BC provides basic functions for system security. For details, see the “Introduction to System Administration” manual [8].

More extensive security functions in BS2000 are implemented by the software product SECOS, which consists of the following components:

- SRPM (System Resources and Privileges Management),
- GUARDS (Generally Usable Access contRol aDministration System)
- GUARDDEF (GUARDs DEFault protection)
- GUARDCOO (GUARDs COOwner protection)
- SAT (Security Audit Trail)
- SECOS-KRB (Kerberos authentication)

These SECOS components are provided by management systems and interfaces which enable each individual user to define a customized set of rights and duties.

Details are provided in the SECOS manuals ([9] and [10]).

4.1.2 Downloading KVP logging files

The KVP logging files contain the BS2000 operating system history at console and KVP level.

The history contains up to 40 KVP logging files per KVP. When 40 files exist, the oldest is deleted when a new KVP logging file is created.

How far back in time the history goes depends largely on how many messages the system concerned issues.

As administrator you can download the KVP logging files and store them on the administration PC for further use.

You can access the KVP logging files via the respective BS2000 system:

- in Native BS2000 mode via the *KVP logging* tab under *Systems -> [<se server> (SE<model>) ->] <unit> (SU<model>) -> BS2000*
- in VM2000 mode via the *KVP* tab under *Systems -> [<se server> (SE<model>) ->] <unit> (SU<model>) -> Virtual machines -> <bs2000-vm>*

Alternatively, access is possible via the *KVP* tab under *Devices -> [<se server> (SE<model>) ->] <unit> (SU<model>) -> BS2000 devices*.

i Security-relevant actions

- **Download confidential data:**

When managing the KVP logging files on the administration PC, remember that these files may contain confidential BS2000 data. You must consequently ensure that only trusted persons can access these downloaded files.

4.1.3 Alternative access to the BS2000 operating system with PuTTY

If you use the access to the BS2000 console and BS2000 dialog integrated into the SE Manager, data transmission between the administration PC and the Server Unit and Management Unit takes place at base system level in encrypted format and is consequently secure.

Alternatively secure access to the BS2000 console, SVP console (only SU /390) and BS2000 dialog can be achieved using the SSH client PuTTY (Version 0.63 and higher) under the following conditions:

- There is a connection to the MU.
- A valid administrator, BS2000 administrator or operator account is specified. Authentication with password entry or installed ssh key is required.
- The CLI command `bs2Console`, `svpConsole` or `bs2Dialog` with the relevant parameters is specified as the follow-up command. An operator is granted access only in accordance with his/her individual rights.
- To avoid line breaks, for a BS2000 console the number of columns should be set to 132. For a BS2000 dialog a character set must be specified which supports the display and the shortcuts which are required in the BS2000 dialog.

Examples for the alternate BS2000 operation under PuTTY can be found in the appendix of the "Operation and Administration" manual [2]. A detailed syntax description of the CLI commands is provided in the CLI command reference, see the SE Manager's online help under *General information -> PDF documents*.

4.2 Secure access to systems on Application Units

As administrator you install in-house software (e.g. software for data backup or databases) on the Application Units and perform other administration and configuration tasks both at application and operating system level.

The administration measures on the Application Unit are solely the customer's responsibility. Consequently you are also responsible for the security of all accesses to the Application Unit and of your iRMC / Management Board (operating system security, password management, forbidding insecure services, administration of the iRMC / Management Board, serviceability, etc.).

i The security in the Application Units has no influence on the security in the other systems on the SE server.

4.2.1 Configuration changes

By default, Application Units are integrated into the status monitoring and the remote service procedures of the SE server. This requires configuration measures in the SNMP configuration of the Application Unit.

SNMP configuration

The Management Unit starts queries to the SNMP agent on the Application Unit in order to obtain information about managing the Application Units.

Details of how to integrate the Application Unit into the status monitoring are described in the “Operation and Administration” manual [2] and in the online help.

i Security-relevant actions

- When you define or modify the SNMP configuration required for status monitoring, you should ensure that only SNMP queries from the Management Unit are allowed.
- Port 161 in the firewall must be opened for the SNMP queries.
- If you want to monitor the Application Unit or applications running on it by means of SNMP or one or more management stations, the information on the actions which are relevant to security is provided in the [section "SNMP"](#).

4.2.2 Access to the iRMC / Management Board of the Application Unit

For Application Unit PY, access is via the iRMC, for Application Unit PQ via the Management Board.

Using the iRMC / Management Board of an Application Unit is mainly intended for the following scenarios:

- User management on Application Unit

i Security-relevant actions

- The `semuser` account is used by the SE Manager as fixed access and may not be deleted by the administrator (see also [section "Integration of Application Unit into the SE Manager"](#)). After configuration by the Customer Support, the `semuser` account is protected with an initial password, which you can obtain from Customer Support. **Change this password immediately after startup.**
- It is possible to create further (personalized) accounts. When you do so, note the privilege strategy predefined on the iRMC / Management Board. You should disable accounts which are not used.

- Powering on/off the Application Unit

For this purpose the predefined account `admin` is available to the administration on the iRMC / Management Board.

- Remote access to the Application Unit console using the “Video Redirection” function. The functionality corresponds to [Access via the local console](#).

i Security-relevant actions Protection functions

- You can log out from the iRMC's / Management Board's web interface by means of *Logout*. When you leave your workstation, this can be used as an alternative or in addition to the locking mechanisms of the administration PC.
- The iRMC's / Management Board's web interface can also be protected against unauthorized access by a *Session Timeout*. The session times out if no activity is detected on the web interface for a particular period (timeout period). You must then log in again.

You can configure this behavior in two ways under *Network Settings -> Ports*:

- > Disable *Enable Auto Refresh*.

This also results in the web interface not being updated automatically.

- > This has the result that with a normal timeout period of 20 minutes the refresh time is disproportionately high, or with a normal refresh time in the minutes range the timeout period is disproportionately low.

4.2.3 Integration of Application Unit into the SE Manager

Access to the iRMC / Management Board of Application Unit

To integrate the Application Unit into the SE Manager (status information, switching on / off, etc.), access to the iRMC / Management Board of the Application Unit is required.

When the Customer Support configures an Application Unit it sets up the fixed account `semuser` with the privileges "LAN Channel Privilege Administrator, Serial Channel Privilege User" and an initial password.

Details of how to integrate the Application Unit into the status monitoring are described in the "Operation and Administration" manual [2] and in the online help.

Access to the Application Unit

This access is required if the Application Unit is operated with the operating system VMware vSphere, Microsoft HyperV or Citrix XenServer.

The administrator provides an account on the AU and configures it and the access password in the SE Manager:

- > *Hardware -> Units -> [<se server> (SE<model>) ->] <unit> (AU<model>) -> Management -> IP configuration, action „Change access data“ in the respective access data group.*

Access to the VM Manager

This access is required if the Application Unit is operated with the Oracle operating system. The access connects to the Oracle VM Manager.

The administrator provides an account in the Oracle VM Manager and configures it and the access password in the SE Manager:

- > *Applications -> User-defined applications -> Administration, action Embed user-defined management application in the group User-defined management applications.*

i Security-relevant actions

- The `semuser` account is used by the SE Manager as fixed access and may not be deleted by the administrator.
- The accounts for the accesses to the AU and the Oracle VM Manager can be changed if necessary.
- If it is necessary to change one of the above passwords, you must make this change immediately in the SE Manager. This is the only way to ensure that the integration of the Application Unit into the SE Manager works (e.g. the status displays).
- Note regarding CSR:
The passwords configured in the SE Manager are part of the MU global data of the CSR backup (refer to [section "Configuration data backup"](#)).
The passwords are restored when the CSR backup is imported if they are no longer available.

4.2.4 Access via the local console

When you toggle the console switch (see the [section "Access via the local console"](#)), you obtain access to the Application Unit's operating system via the local console. The type of access (e.g. shell or desktop) depends on the operating system installed.

You are responsible for providing and managing access accounts.

The range of commands and functions available depends on the operating system used.

i Security-relevant actions

- When you leave your workstation you should log out explicitly using the method which corresponds to the interface, e.g. at shell level with the `exit` command.
- Switching over the console switch or switching the console off does not result in an automatic logout.

4.3 Secure access to XenVMs on SU300

Access to the console of a XenVM should be protected with a password, as closing the console window does not lock the console or desktop. The console is thus available to the next user without protection. A console password can be set either when the XenVM is created or by retroactively setting the XenVM attributes.

The following must be borne in mind with respect to the console password:

- The password can be up to 8 characters long.
- It should include a certain level of complexity (this is not checked when it is entered).
- The password is not set on a user-specific basis. It is the same for all users of the particular XenVM console.
- If access does not take place via the SE Manager, the password at least offers simple protection for access to the XenVM console.
- The following applies for protecting the password:
 - Transfer from the client to the server takes place with SSL encryption.
 - The password is masked out in all XenVM displays.
 - The XenVM configuration data is access-protected (access requires root authorization).
 - The console passwords are contained in CSR backups, but only system administrators and Customer Support have access to these backups.

i Security-relevant actions

- **Reset the console password:**

The XenVM console can then be accessed without a password. This status should be avoided for security reasons.

- **Import a CSR backup:**

When a CSR backup is imported, the console passwords are reset to the status of the backup, i.e. if necessary, console passwords are also reset. You should check whether password protection still exists and, if necessary, set a password.

- **Download a CSR backup to the administration PC:**

The file must be protected against unauthorized access, otherwise console passwords might be obtained without authorization.

5 Remote service (AIS Connect)

Remote service ensures that when a fault occurs a service call is sent to the Support Center from the customer system's Remote Service Endpoint and that Customer Support has the opportunity of establishing a remote access.

The connection is set up over the internet. AIS Connect is configured at the Remote Service Endpoint for this purpose. The Remote Service Endpoint on an SE server is the Management Unit.

When access is permitted, the initiative for connection setup always lies with the customer side in the form of regular contacts of the service agent with the Support Center, which can be reached over the internet. When necessary, the Support Center employs these connection setup options to log in on the customer side.

Jobs from the Support Center to the service agent on the Management Unit (e.g. file transfer, remote access) are received by the latter. The service agent executes these jobs by, for example, establishing the tunnel for them in the case of remote access.

With an SSH session, the service engineer at the Support Center obtains access to the Management Unit under the `tele` account. Since `tele` is only an access account without any further functionality, the service technician generally subsequently changes to the `service` account to perform the maintenance work.

Remote service satisfies stringent security requirements:

- The initiative for connection setup always comes from the customer side. This ensures that only the configured Support Center obtains access to the customer system.
- File transfer always takes place in encrypted format.
- The customer can use the shadow terminal function to observe the work of Customer Support or even to intervene in it. Several security levels can be set.
- The customer can retrieve information on the currently used AIS Connect connections. In emergency situations, they can intervene and terminate an existing connection.
- The work of Customer Support is logged. The customer can read these logs and at all times trace which actions Customer Support performed.
- AIS Connect also supports integration into a proxy server configuration (see ["Using the "shadow terminal" function"](#)).

Outgoing connections are service calls and regular messages of the system program PRSC (Periodical Remote System Check) which are sent to Customer Support once a week.

Incoming connections are connections which Customer Support creates in order to clear a fault or to implement preventive measures. To do this, Customer Support sets up a connection to the Remote Service Endpoint (Management Unit) and then, if required, switches to the system to be serviced (e.g. the BS2000 system).

If it is necessary, as an administrator (and to a lesser extent as an operator) you can change the remote service configuration or intervene in a service operation which is currently running, see the "Operation and Administration" manual [2].

i Important!

Please discuss every change to the remote service configuration with the Support Center, otherwise you will put the serviceability of your SE server at risk.

5.1 Service account

On a Management Unit the `service` account is provided for Customer Support on the base system. Under this account the service engineer works on all available interfaces (web interface, Linux desktop of the local console, shell level), both locally on site and also remotely via the remote service access.

The `service` account can also access the BS2000 console. The following must be taken into consideration when logging entries on the BS2000 console:

- In the KVP logging files it is possible to distinguish the account (e.g. `admin` or `user1`) under which an entry was made.
- In BS2000, on the other hand, only the console mnemonic (e.g. `C0`) enables you to recognize who made an entry in the `CONSLOG` files.

Consequently console entries of different users are only unambiguously identifiable if every user uses a different console mnemonic when accessing the console.

To achieve such differentiation, you can assign the operator accounts different console MNs (by means of individual access rights). For administrator accounts, BS2000 administrator accounts and in particular for Customer Support, it is only possible to reach an agreement on using particular unambiguous console MNs.

i Security-relevant actions

- Change the console mnemonic for operator accounts
In the SE Manager, *Authorizations* -> *Users* -> *Individual rights* enables you to enter the console access to a system with a specific console MN. The change takes effect immediately.
- Define the console mnemonic in BS2000 OSD/BC It must be ensured that the assigned console mnemonics are defined in BS2000 so that the console access functions.
You define the console MNs in the `/BEGIN OPR` section of the BS2000 parameter files (e.g. `SYSPAR.BS2.nnn`) using the keyword `DEFINE-CONSOLE`. Here the `TELESERVICE=YES` parameter ensures that the console is not taken away from Customer Support (i.e. the console cannot become either a standby console for another console or a master).
Details on configuring the console mnemonic are provided in the manual "Introduction to System Administration" [8].

5.2 Logging support operations

The sessions, both SSH and VNC sessions, are always logged. You can view logging files of SSH sessions using the CLI command `aisLog`. You can load logging files of VNC sessions onto your PC and view them there in the web browser.

For information, see the “Operation and Administration” manual [2].

i As logging files of VNC sessions can become very large, the administrator must check and, if necessary, delete them from time to time.

5.3 Using encryption

Communication always takes place using HTTPS (HyperText Transfer Protocol Secure). The underlying encryption protocols SSL 3.0 (Secure Sockets Layer) and TLS 1.2 (Transport Layer Security) are supported.

5.4 Using the "shadow terminal" function

With the remote service standard configuration the Support Center can at all times access the system and perform its work without any assistance or permission from the customer.

You can adjust the remote service configuration to your security criteria (e.g. lock or open the service access).

The SE Manager provides all the functions you require to administer the service access. You can change the service access and the usage of the shadow terminal at any time (lock it or open it with different settings). You can observe the work the service engineer performs, participate in it or have yourself guided by the engineer.

Irrespective of the access setting, you receive information on the current Teleservice sessions (name of the service engineer and access type) and the current status of the AIS agent.

i Security-relevant actions

- Change the Customer Support access:

The following settings are possible for the service access of AIS Connect:

- Access permitted, without shadow
Customer Support obtains access to the system at all times and does not need to inform you to do this. No shadow terminal is available to track the activities of Customer Support.
 - Access permitted, shadow possible
Customer Support obtains access to the system at all times and does not need to inform you to do this. A shadow terminal can be opened to track the activities of Customer Support.
 - Access permitted, shadow mandatory
Customer Support obtains access to the system only if you open a shadow terminal beforehand. You can track the support activities on the shadow terminal.
 - Access not permitted
Customer Support obtains no access to the system.
- Change the AIS proxy configuration:
If the internet connection is established via a proxy server, the IP address of the proxy server, the port number and, if required, the account and password for the proxy authorization are entered in the AIS proxy configuration.
If your proxy server configuration changes, you must adjust the AIS proxy configuration accordingly. You must adjust the firewall settings on the proxy server. Only if you do so is serviceability retained.

You execute the specific actions in the SE Manager as administrator or operator (not AIS proxy configuration). The functions are provided in the *Remote Service* tab under *Hardware -> Units [-> <server> (SE<model>)] -> <unit> (MU) -> Service*.

In a multi-MU configuration, you have to perform the same actions on each MU!

A description of how you work with the shadow terminal is contained in the section "Managing the service access" in the "Operation and Administration" manual [2].

5.5 Monitoring the current usage of the service access

The *AIS Connect Sessions* group displays the sessions that currently use the service accesses to the Management Unit and to the external assets.

i Displaying the sessions is only possible in case of direct MU connection, not in case of connection via a gateway.

You can delete a session by using the *Delete* icon. This will abort the current usage of the service access.

i Because this may abort an important service operation, it should only be done in emergency situations.

In an SE server configuration with multiple MUs, you will receive a complete overview over all service accesses when you view the sessions on each MU.

5.6 Access to external assets

AIS Connect enables Customer Support connections to be configured via the Management Unit to selected storage systems which in this context are referred to as **external assets**.

These connections are configured by Customer Support in agreement with the customer.

The SE Manager displays the configured external assets in the *Remote Service* tab under *Hardware -> Units [-> <se server> (SE<model>)] -> <unit> (MU) -> Service*.

As administrator you can at all times modify the Customer Support access to specific external assets (allow or not allow).

i Security-relevant actions

- Changing Customer Support access to external assets:

The following settings are possible:

- Access allowed
Customer Service has access to the external asset at all times.
- Access not allowed
Customer Support obtains no access to the external asset.

Even in the **Access not allowed** status it is ensured that the Teleservice messages are forwarded to the Support Center.

In an SE server configuration with multiple MUs, you have to make the same settings on each MU.

A description is provided in the section “Managing service access” in the “Operation and Administration” manual [2] and in the online help.

6 Configuration and diagnostic data

The description is divided into the following sections:

- Configuration data backup
- Diagnostic data

6.1 Configuration data backup

You use a CSR backup (CSR = Configuration Save and Restore) to back up the configuration data of a unit (Management Unit, HNC or Server Unit x86) in an archive.

CSR backups are retained when reinstallation takes place.

In a single-MU configuration, you can use a CSR backup to recreate the configuration of the respective base system as of the time of the backup.

In a multi-MU configuration, there is a difference between MU-specific and MU-global data.

- For MU-specific data:
The current MU-specific data are replaced by the old data.
- For MU-global data:
The current MU-global data are not changed, only old, no longer existing MU-global data are restored. The MU-global data are the configured authorizations (accounts, LDAP configuration, IP based access rights), the configuration of the alarm management, the configured Application Units, the configured applications, the configuration of the FC networks, the configured SU Clusters.

i Security-relevant actions

As administrator, in the SE Manager you can download configuration data backup archives to the administration PC in order to back them up in case a disaster occurs.

If required, as administrator you can also upload the backup.

The CSR backup contains base system data which is relevant to security. However, it contains no customer data from your BS2000 systems which are run on or with it.

This also applies for customer data which resides in XenVM systems.

The data collected in the archives cannot simply be used in the form it is to intrude in or compromise the system. Nevertheless, you should take care:

- When managing the archives on the administration PC, ensure that only trusted persons can access these archives.
- When uploading, ensure that the data in an archive is activated only on the required target system and on no other system beside this.

Recommendation: For the purpose of data security, perform a CSR backup after every configuration change and store it in accordance with your security policy.

Note: A CSR backup contains no account passwords.

6.2 Diagnostic data

The administrator can generate diagnostic data on the units (Management Unit, HNC and Server Unit x86) and make this data available to Customer Support when the latter requires this support.

This function is also accessible for the other user roles.

i Security-relevant actions

In the SE Manager, as administrator you can download diagnostic data to the administration PC in order, for example, to send it by email to Customer Support.

The diagnostic data contains base system data which is relevant to security.

However, it contains no customer data from your BS2000 systems which are run on or with it.

This also applies for customer data which resides in XenVM systems of an SU x86.

The diagnostic data collected in the archives cannot simply be used in the form it is to intrude in or compromise the system. Nevertheless, you should take care:

When managing the diagnostic data on the administration PC and sending it to the Support Center, ensure that these diagnostic data can only be accessed by trusted persons.

7 Network security

The description is divided into the following sections:

- Network services
- IP-based access restriction
- Security at Net Unit level
- Net-Storage
- SNMP

7.1 Network services

The table below describes the services which are released in the base system of the Management Unit. Using ACL the services can be restricted further for specific networks, see [section "Security at Net Unit level"](#).

HNC and SU x86 are protected by default and are not described in detail.

Type	Name and Port	Application
TCP	ssh (22)	Communication at shell level (e.g. BS2000 console/dialog, SVP console, shadow terminal)
TCP	http (80)	Communication via this port is always redirected to https (443).
TCP	https (443)	Communication between the browser (e.g. on the administrator PC) and the system's web interface (e.g. SE Manager)
TCP	iascontrol-oms (1156)	PRSC/prscx (Periodical Remote System Check) regularly sends sign of life messages to the Support Center
TCP	4178	Optional: for communication (http) with StorMan
TCP	5800	Browser access to the VNC shadow functionality of the remote service (AIS Connect)
TCP	5900	VNC viewer access to the VNC shadow functionality of the remote service (AIS Connect)
TCP	10021-10022	In the case of an SKP network (redundant SKP) for SKP-SKP communication
TCP	rs2_rctd (13333)	for remote service connections of BS2000
UDP	domain (53)	Integration into the Domain Name Service (DNS)
UDP	multicast-ping (9903)	for monitoring components
UDP	ntp (123)	Integration into the Network Time Protocol (NTP)
UDP	snmp (161)	For reading SNMP access by management stations
UDP	snmptrap (162)	For receiving SNMP traps from the hardware monitoring
UDP	syslog (514)	for monitoring components
UDP	dhcpv6-client (546)	Optional: the DHCPv6 client port is used when a LAN interface is configured accordingly
ICMP	-	Internet Control Message Protocol (ping)

Table 1: Ports for incoming connections

These ports are released for incoming connections by means of the packet filter (SuSEfirewall2) which is installed on all the systems. All other ports are locked.

All ports are released for outgoing connections in the packet filter.

A port for incoming connections which is released in the packet filter does not constitute a security risk provided the service using this port is not started because the system blocks every connection attempt.

Note on HNC and SU x86

When using the Net-Storage functionality via the MANPU and DANPU networks, there are direct outgoing connections on these units, but these do not pose a security risk.

Settings of the external firewall

The ports described in [table 1](#) may need to be enabled in the external firewall. Exceptions are TCP 10021-10022, which serve the redundant SKP functionality of the MUs within the SE server.

In addition, if necessary, ports for further optional functions with outgoing connections must also be enabled.

Examples:

- Connects to an LDAP server, TCP port 389 by default
- NFSv4 port TCP 2049 using Net-Storage functionality
- In the case of ROBAR, the ports required for access to the storage systems must be unlocked.

7.2 IP-based access restriction

The administrator can configure access to the MU and thus to the SE Manager in such a manner that access is possible only for explicitly entered IP addresses or for IP addresses from an explicitly entered IP network.

The current setting is shown by the *IP-based access rights* tab in the menu *Authorizations -> Configuration*.

By default the list for access restrictions is empty, and access is permitted without restriction for all IP addresses.

i Security-relevant actions

- With the first entry (IP address or IP network) you enable IP-based access restriction to the MU. Access is then only possible for IP addresses which are entered either explicitly or via an IP network.
Because each entry takes effect immediately, you should always observe the following:
With the first entry, enter your own IP address (or the subnetwork). Otherwise you will lock yourself out and will lose access to the SE Manager!
- When you delete the last entry from the list for access restriction, access to the MU is once again possible for all IP addresses without restriction.

7.3 Security at Net Unit level

The services for the various networks can be further restricted at Net Unit level by means of ACL.

You can lock or release individual TCP/UDP ports (services) for the DANPU<xx>, MANPU, MONPU, DANPR<xx>, and MONPR<xx> networks:

- Either the administrator defines an ACL list of the type "permit" in which all released services (ports) are explicitly entered.

i After the ACL of the type "permit" has been configured, the list is initially empty. Access to the network is thus locked for all services (ports).

- Or the administrator defines an ACL list of the type "deny" in which all the locked services (ports) are explicitly entered.

One ACL list each can be defined for IPv4 and IPv6.

7.4 Net-Storage

As net clients the units HNC and Server Unit x86 support BS2000 access to a Net-Storage. In this case the HNC is the net client for the BS2000 systems which run on the SU /390, and the SU x86 is the net client for BS2000 systems which run on it.

The configuration of the access to a Net-Storage is administered in the SE Manager for each net client:

- The net client requires access rights for the net server which provides the Net-Storage. A user ID and a group ID are entered which have the necessary access rights to the released storage on the net server.
- Each Net-Storage connection must be configured in the network.

7.5 SNMP

Central SNMP integration of the SE server is administered using the SE Manager on the Management Unit. The preconfiguration is created in such a manner that you can also use SNMP to monitor the other units on the management stations provided a configuration for SNMP integration exists on the Management Unit (read access, trap receiver):

- Queries regarding the Server Unit /390 are possible on the Management Unit (see the private MIBs).
- Management stations can address the SNMP agent on the Server Unit x86 or HNC and query data (the SNMP agent supports the MIB-II and private MIBs for queries).
- In defined error situations (e.g. status changes) the SNMP agent on the Server Unit x86 or HNC sends traps to management stations.
- On Application Units, on the other hand, you must configure SNMP yourself.

The following private MIBs must be imported to the management station in order to permit access in read mode and to enable the traps to be interpreted:

- `/usr/share/snmp/mibs/FUJITSU-SESERVER-MIB.txt`
- `/usr/share/snmp/mibs/FUJITSU-SU390-MIB.txt`

At the Management Units and Server Units x86, ServerView RAID periodically checks hardware components. These events are reported by trap, even in good case with the weight `NOTIFICATION`. Text example of such a successful test: "*Patrol Read started*" and "*Patrol Read finished*".

In order for ServerView RAID's traps to be correctly represented by the management station, the MIB `/usr/share/snmp/mibs/FSC-RAID-MIB.txt` must be imported to the management station.

i The traps usually contain neither the trap weight nor the message text. This information can only be read from the MIB.

Access to MIB files on the Management Unit is, for example, possible under any administrator account with `scp` (secure copy).

i Security-relevant actions

- When creating the SNMP configuration, ensure that only trusted management stations can access the Management Unit resp. the Server Units of the SE server by configuring the read community with a restriction to the management station.
 - As far as possible use only specific read communities (not *public*).
 - Grant access only to precisely defined management stations (by specifying their host names).
- When creating the SNMP configuration, ensure that traps are sent only to trusted management stations from the Management Unit resp. the Server Units of the SE server.
 - As far as possible use only one specific trap community (not *public*).
 - Enter only the management stations intended for this purpose as trap receivers.

8 Security of the base system

The description is divided into the following sections:

- Hardening the base system
- Software signature
- Digital certificates
 - Confirming/importing a certificate in the web browser
 - Using the standard certificate
 - Creating and activating a new self-signed certificate
 - Requesting an SSL certificate
 - Uploading and activating a customer-specific certificate
- Security fixes

8.1 Hardening the base system

The FUJITSU Server BS2000 SE Series with Management Unit, HNC and Server Unit x86 are systems which satisfy stringent security requirements. The statically implemented security of a hardened system which cannot be influenced by administration activities is involved here.

The base system of the Management Unit, HNC and Server Unit x86 is a Linux system based on SUSE Linux Enterprise Server (SLES) 11.

The base system is used exclusively to administer the systems themselves. No normal user operation with customer applications takes place.

These systems are characterized by the following features:

- Only signed software components which are required for operation are installed.
- The base system software which is used on the systems is supplied on a CD/DVD which contains a checksum. During installation the checksum is used to check whether all the packages on the CD are uncorrupted, i.e. their status is the same as that when they were produced.
- Nonprivileged accounts are used for user access.
- These accounts are equipped with clearly defined (and restricted) functions and access rights as part of a differentiated role concept.
- No access to the system is possible outside of this role concept.
- A rights escalation is not possible in the context of this role concept. Access to the `root` account is locked. Rights which are required for maintenance/diagnostics or for updates by FUJITSU Customer Support are implemented by extended rights of the *Service* role.
- The role and user strategies enable personalized accounts to be configured and passwords and password attributes to be managed.
- Actions which lead to configuration or status changes are logged and can be assigned to the persons who perform them.
- The data traffic between administration PCs and the base system is always encrypted.
- All unused network services are disabled.
- Each firewall within a system restricts network access to the network ports required.

The configuration of the base systems is based on the recommendations of the Center for Internet Security (CIS, <http://www.cisecurity.org>).

Deviations from these recommendations occur only with functions which are required for operating the base system (e.g. a web server which provides the user interface is always active for the SE Manager in the base operating system). These deviations from the CIS recommendations do not lead to security gaps.

8.2 Software signature

The software used on the Management Unit, HNC and Server Unit x86 is supplied in packages which are provided with a signature.

- The packages of the underlying base software Linux SLES 11 are signed by the vendor.
- The specific packages for the Management Unit, HNC and Server Unit x86 are signed by FUJITSU.

During installation the signature is used to check whether the status of a package is unaltered, i.e. corresponds to the production status.

If the signature check fails, installation of the package is rejected.

8.3 Digital certificates

To use HTTPS/SSL, not only an SSL key pair is required on the Management Unit, but also a (digital) SSL certificate. This server certificate performs the following two tasks:

- The certificate is always system-specific (contains the FQDN) and proves the online identity of the system concerned for the browser on the administration PC.
- The certificate provides the public key with which the browser encrypts its messages to the server on the administration PC.

A self-signed, system-specific certificate which was generated on the system is preinstalled as the standard certificate on each Management Unit.

You can also use other certificates instead of the preinstalled self-signed certificate. The following options are available:

- Use of a self-signed certificate

The certificate must comply with the X.509 standard with PEM encoding and the certificate file must have the suffix `.key`.

A certificate of this type is preinstalled on the system as the standard certificate. It must be explicitly confirmed or imported on any browser with which the SE Manager operates.

- Use of a customer-specific certificate (signed by a customer CA)

If the customer-specific policy specifies the use of such a certificate, it can simply be installed.

The certificate is as a rule derived from a customer-specific root certificate. Such a certificate is known to the browsers the customer uses and is accepted without an inquiry (i.e. without being confirmed or imported).

- Use of a commercial certificate (signed by a root CA)

A certificate of this type is created for a fee by a trusted root certification authority (CA) and is therefore known to all browsers. Consequently every browser accepts such certificates without an inquiry.

8.3.1 Confirming/importing a certificate in the web browser

If the web interface called uses a self-signed certificate (i.e., for example, the preinstalled standard certificate), web browsers reject the call for the page because, from their viewpoint, the certificate is not trusted.

To permit pages of the SE Manager to be loaded in the browser at all, you must either temporarily accept the certificate error or you can download the Management Unit's CA certificate and import it permanently in the browser.

The procedures described in principle below are based on Internet Explorer Version 11 or higher and differ according to the browser used and the version. You will find details of the specific procedures in your browser's online help.

Downloading a CA certificate and installing it in the browser

To prevent a certificate error in future, you can download the Management Unit's CA certificate and install it in the browser.

i In an SE server configuration with multiple MUs, you have to perform the same actions for each MU.

- > Select *Authorizations* -> *Certificates* [-> <mu-name> (MU)], *Certificates* tab. The table displays the current certificate of the MU:
- > In the *Issued by (CN)* row click the *Download CA certificate* icon.

After the download, you can install the certificate in your browser.

- > Open the certificate file (standard name <mu-name>-ca.crt) and answer the security warning that displays "Unknown Publisher" by clicking *Open*.

The information of the certificate is shown:



- > Select *Install Certificate* and click *OK*.

The browser's certificate import wizard takes you through certificate installation step by step.

- > Click *Next*.
- > Select *Place all certificates in the following store* option and click *Next*.

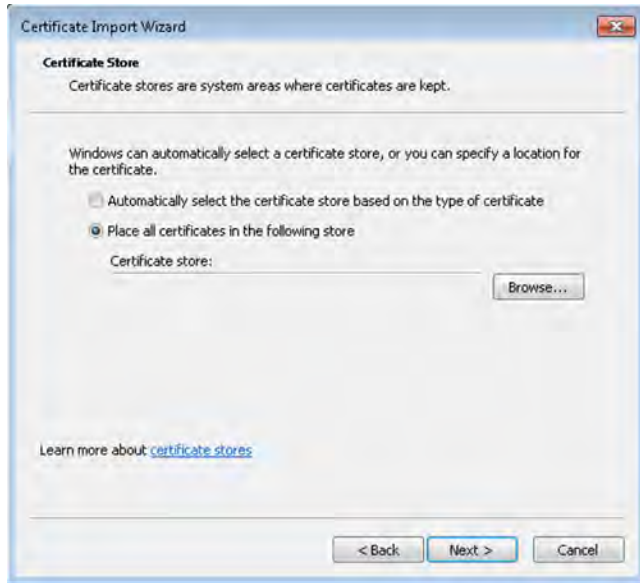

- > Select *Trusted root certification authorities* as the certificate memory and click *OK*.

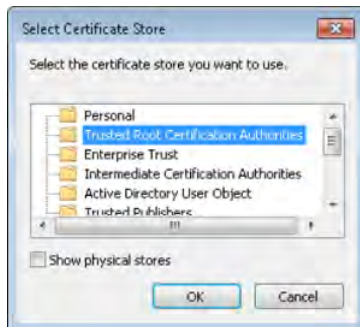

- > Confirm the request that now displays your selection again by clicking *Finish*.

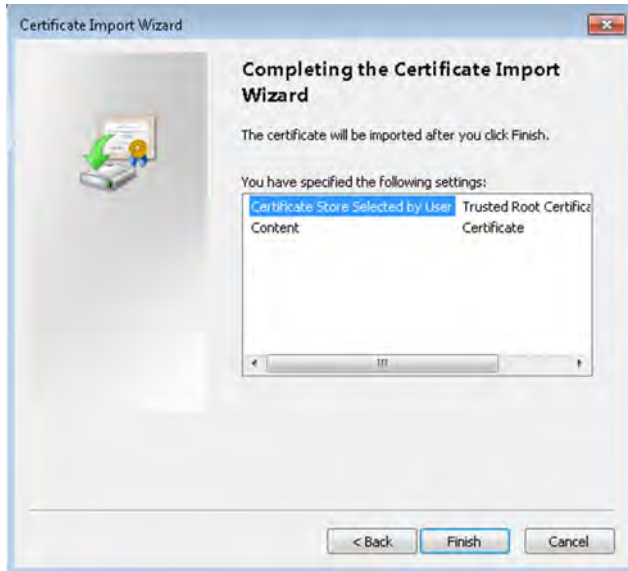

- > Confirm the subsequent security warning, which contains the certificate name and the "fingerprint" with *Yes*. The certificate will now be installed.
- > After successful import, terminate the certificate import wizard by selecting *OK*.



Temporarily accepting a certificate error

- > Open your web browser.
- > In the browser window call the SE Manager of the required system.



The web browser reports a certificate error.

-
- > Confirm that the website should be loaded.

You are shown the login page. The browser's address bar displays *Certificate Error* as a warning.



You obtain information on the possible security risk when you click *Certificate Error*. Check the certificate displayed. Continue only if no doubts exist about the certificate.

The certificate has now been temporarily accepted for this session, and you can now work with the SE Manager of this system.

8.3.2 Using the standard certificate

A self-signed, system-specific certificate is preinstalled on the Management Unit. This is not known directly by the web browsers, nor is it derived from a known root certificate.

A standard certificate is automatically generated and activated each time the Management Unit is renamed (the FQDN is changed). The new standard certificate must then of course be accepted by or imported to the browsers.

The main features of this certificate are:

- The *Common name (CN)* is identical to the fully qualified domain name (FQDN) of the base operating system.
- The Validity period is 10 years.
- The fingerprint which unambiguously identifies the certificate is generated using the SHA-1 algorithm and RSA encryption.

As the browser does not know the self-signed certificate, when the SE Manager is called it requests the user to accept the certificate temporarily for the current session or to import it permanently.

If you call the SE Manager on the local console, you must also confirm or import the standard certificate, because the browser used on the Gnome desktop does not know the certificate, either.

You are granted access to the SE Manager of the system component only if the certificate is temporarily accepted or permanently imported.

If in doubt, you should first read and cross-check the certificate before accepting it temporarily or importing it permanently.

Displaying the current certificate

- > Select *Authorizations* -> *Certificates* [-> <mu-name> (MU)], *Certificates* tab.

An overview of the most important attributes of the current certificate is displayed in the work area.

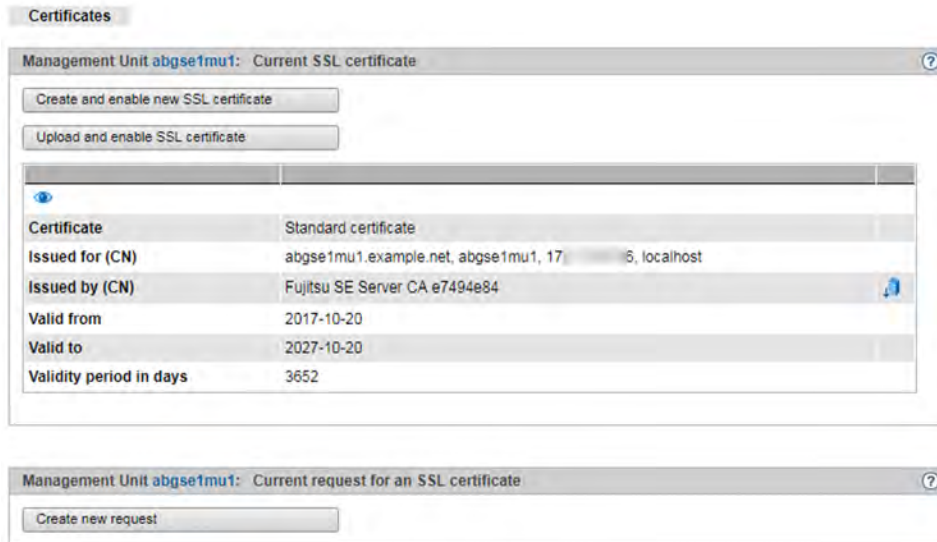

Certificate

Type of certificate: *Standard certificate* or *User-defined*

Issued by (CN)

FQDN of the server for which the certificate was issued.

Issued by (CN)

Issuer of the certificate (e.g. organization). In the case of user-specific certificates this is also the FQDN of the server for which the certificate was issued.

Information on the attributes *Valid from*, *Valid to*, *Validity period in days* and *Email address (emailAddress)* is provided in the online help.

Detailed display of the certificate

- > Select *Authorizations* -> *Certificates* [-> <mu-name> (MU)], *Certificates* tab.
- > Click the *Details* icon.

All the attributes of the certificate are displayed in a dialog.

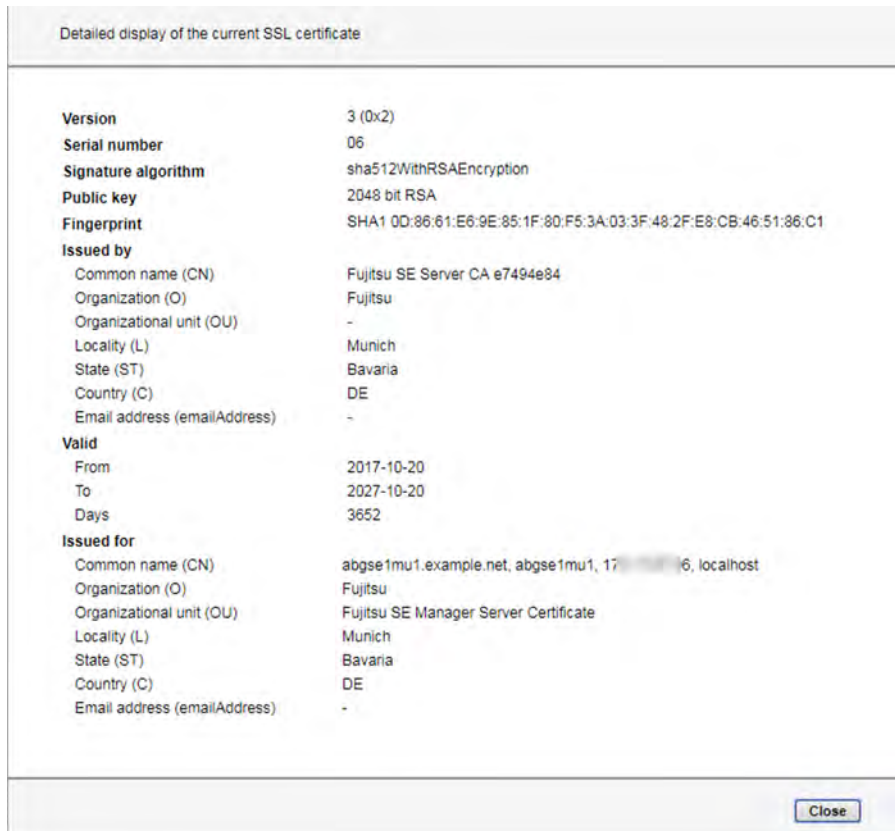

8.3.3 Creating and activating a new self-signed certificate

The preinstalled standard certificate contains data which is naturally not customer-specific.

If you want to work with a certificate with customer-specific data, you can at any time create and use such a certificate. This action can also be necessary when you want to renew a certificate. Proceed as follows:

- > Select *Authorizations* -> *Certificates* [-> <mu-name> (MU), *Certificates* tab.
- > Click *Create and enable new SSL certificate* above the table.

A dialog opens:

Create and enable SSL certificate

Create and enable a new SSL certificate for Management Unit **abgse1mu1**.

Common name (CN) abgse1mu1.example.net, abgse1mu1, 17...6, localhost

Organization (O) ⓘ

Organizational unit (OU) ⓘ

Locality (L) ⓘ

State (ST) ⓘ

Country (C) ⓘ

Email address (emailAddress) ⓘ optional

Validity period in days ⓘ

⚠ The SSL certificate previously enabled will be overwritten.

Create and enable Cancel

Enter the most important data for the certificate. The value for the *Common name (CN)* is predefined and contains the system's fully qualified domain name (FQDN). Information on the attributes *Organization (O)*, *Organizational unit (OU)*, *Locality (L)*, *State (ST)*, *Country (C)*, *Email address (emailAddress)*, *Validity period in days* is provided in the online help.

- > Click *Create and enable*.

The certificate is created, activated immediately and displayed as the current certificate.

Notes:

- When a certificate is activated, the web server is also automatically rebooted.
- As the web browser does not know how trustworthy the new certificate is, like the standard certificate it must be explicitly accepted or imported (see the [section "Confirming/importing a certificate in the web browser"](#)).

8.3.4 Requesting an SSL certificate

When you want to use a system-specific certificate which was signed by a CA (certification authority), the SE Manager supports you in creating the request:

- > Select *Authorizations* -> *Certificates* [-> <mu-name> (MU)], *Certificates* tab.

The *Current request for an SSL certificate* group shows whether a request has already been submitted: if one has, the attributes for the requested certificate are displayed.

- > Click *Create new request* in the *Current request for an SSL certificate* group.

i Any request which has already been created is overwritten.

A dialog opens:

Create SSL certificate request

Create new SSL certificate request for Management Unit **abgse1mu1**

Common Name (CN) abgse1mu1.example.net, abgse1mu1, 17...6, localhost

Organization (O) **i**

Organizational unit (OU) **i**

Locality (L) **i**

State (ST) **i**

Country (C) **i**

Email address (emailAddress) **i** optional

Create Cancel

Enter the most important data for the requested certificate. The value for the *Common name (CN)* is predefined and contains the system's fully qualified domain name (FQDN). Information on the attributes *Organization (O)*, *Organizational unit (OU)*, *Locality (L)*, *State (ST)*, *Country (C)*, *Email address (emailAddress)* is provided in the online help.

- > Click *Create*.

The request is created and displayed in the *Current request for an SSL certificate* group. To enable you to send the request to the certification authority by email, first download it to your administration PC using the *Download request* icon.

When the signed certificate is returned to you, enter the certificate in the system: see the [section "Uploading and activating a customer-specific certificate"](#) and [section "Using the standard certificate"](#).

Notes:

- When the certificate signing request is created, it is linked to the system's standard SSL key. If this key is changed in the system in the time between the certificate signing request being created and the signed certificate being entered in the system, the certificate cannot be used.
- A new standard SSL key is created when reinstallation takes place or when the host name is changed.

Consequently reinstallation should not take place and the host name should not be changed in the time between the certificate signing request being created and the signed certificate being entered in the system.

8.3.5 Uploading and activating a customer-specific certificate

Instead of a self-signed certificate generated in the system (standard certificate or user-defined certificate), you can use a certificate of your own to access the system's SE Manager.

A certificate signing request was generated in the system for the certificate (see the [section "Requesting an SSL certificate"](#)) and sent to a certification authority. As soon as the certificate signed by the CA (certification authority) is available to you, you can upload and activate it:

- > Select *Authorizations* -> *Certificates* [-> <mu-name> (MU)], *Certificates* tab.
- > Click *Create and enable SSL certificate*.

A dialog opens.

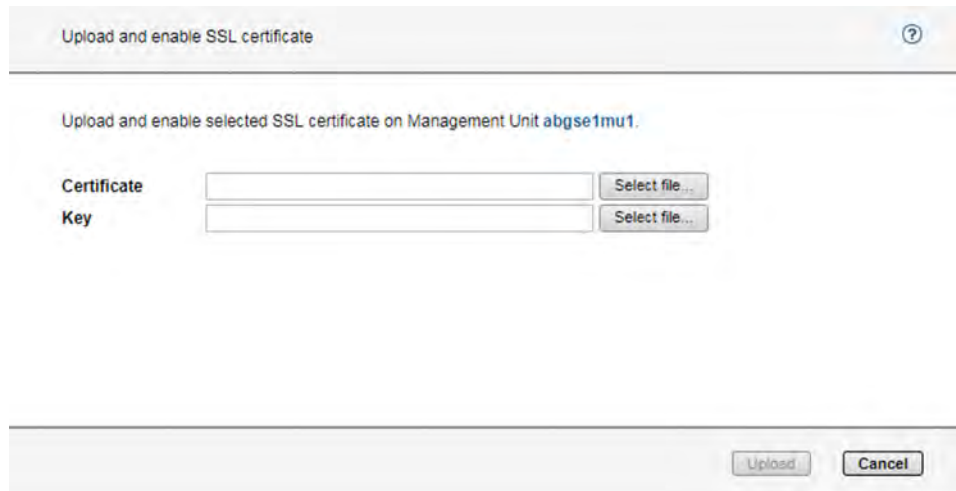

Certificate

- > Click *Select file...* to select a certificate file on your administration PC.

Key

If necessary, select a suitable key file. A key file is required only if the certificate was created on another system. If nothing is specified, the default key is used.

- > Click *Select file...* to select a key file on your administration PC.
- > Click *Upload* to start the file upload.

The files specified are uploaded into the target system, activated immediately and displayed as the current SSL certificate.

Notes:

- When a certificate is activated on the target system, the web server is also automatically rebooted with the new certificate. A brief interruption of the SE Manager's connection to the system can occur.
- If the web browser used (on the administration PC or local console) knows that the new certificate is trusted or knows its root certificate, no further action is required.

-
- If the web browser does not know that a certificate is trusted, the certificate must be explicitly confirmed or imported (see the [section "Confirming/importing a certificate in the web browser"](#)).

8.4 Security fixes

Security fixes are collections of updates for the Linux-based base systems of the Management Unit, HNC and Server Unit x86. Security fixes enhance protection for the system concerned, e.g. against unauthorized intrusion and against attacks from the outside.

Up-to-date security fixes must be installed regularly when security requirements are more stringent, in particular when the system concerned can be accessed not only from a protected management network, but also from the outside.

Up-to-date security fixes are provided on the support sites of FUJITSU on the internet or (when requested) on CD/DVD, and are always installed on site by the administrator.

i Security-relevant actions

Security fixes are provided for the system concerned (Management Unit, HNC or Server Unit x86) and managed on this system. You must therefore perform the activities described below for each of the systems used (i.e. on an SE server on the Management Unit, HNC and Server Unit x86):

- Clarify which security fixes need to be installed.
- Obtain any security fix required from the FUJITSU download server on the internet and download the security fix to any directory on the administration PC.
In exceptional cases you obtain the security fix from Customer Support on CD/DVD.
- If the security fix is located on the administration PC, you must transfer it to the system concerned. If it is supplied on CD/DVD, you must transfer it to the hard disk of the system concerned.
- Install the security fix (if it can be installed).
- If the installed security fix has the installation type *Reboot*, it only takes effect after a reboot (status "not active").

You need a maintenance window to reboot the Server Unit.

When the Management Unit is rebooted, BS2000 consoles and dialogs and the SVP console cannot be operated. Furthermore, any LOCLAN connections which are employed are interrupted, and EMFILES cannot be used. If a redundant Management Unit exists, it can be used to operate BS2000.

When the HNC is rebooted, the ZASLAN connections are interrupted. If a redundant HNC exists, BCAM switches the connections to it if this is specified in the configuration.

9 Logging actions in the system (audit logging)

The internal audit logging function logs all actions that are executed on a Unit (MU, SU, HNC) of the SE server configuration via the SE Manager, an add-on or a CLI command and that cause a configuration change or status change in the system. Logins are also logged. Pure display functions are not logged.

Thanks to the logging entries, the administrator can always use the *Audit Logging* tab under *Logging* -> *Audit Logging* to review who performed which action with which result and when. This enables in particular all actions in the system which are relevant to security to be assigned unambiguously to an “originator”.

Audit logging

Audit logging entries

Period: 2019-07-18 11:10:00 - Oldest entry from: 2018-05-01 12:00:01

1 to 32 of 2447 Page 1 of 77 Go to page 1 Per page 32

Date	Unit	Account	Component	Type	Message
	<i>Filter</i>	<i>Filter</i>	SEM	All	<i>Filter</i>
2019-09-10 15:20:29	abgsilver	admin	SEM	Login successful	Login to SE Manager successful; Account=admin; IP address=10.172.180.180
2019-09-10 15:20:22	abgsilver	leiadm	SEM	Logout	Logout from SE Manager; Account=leiadm; IP address=10.172.180.180
2019-09-10 15:20:16	abgsilver	leiadm	SEM	Access	Open terminal window; Management Unit=abgsilver
2019-09-10 15:19:58	abgsilver	leiadm	SEM	OK	Action=Add new account; Type=ldap; Role=admin; Account=lstuser; Name=-; Comment=-;
2019-09-10 15:19:46	abgsilver	leiadm	SEM	Start	Action=Add new account; Type=ldap; Role=admin; Account=lstuser; Name=-; Comment=-;

10 Event logging and alarm management

The *Event Logging* function logs all events that occur and displays the logged events under *Logging -> Event Logging* in the *All events* tab. To provide a better overview, the recent events that you have not yet seen are also displayed in the *Current events* overview. The Dashboard displays a summary of this tab in the *Events* tile.

Current events **All events**

All events ?

Period: 2019-08-10 00:00:00 - Oldest entry from: 2018-05-03 14:17:38

33 to 64 of 7352 Page 2 of 230 Go to page 2 Per page 32

Date	Weight	Unit	Component	Message
	All	Filter	All	Filter
2019-09-09 08:23:29	NOTICE	abgblack	Cluster	Cluster state of 'redpuma' changed from 'INACTIVE' to 'NORMAL'
2019-09-09 08:23:07	NOTICE	abgblack	Cluster	Cluster state of 'redpuma' changed from 'NORMAL' to 'INACTIVE'
2019-09-09 08:21:27	NOTICE	lodz	M2000	M2000 activated
2019-09-09 08:11:41	NOTICE	lodz	M2000	M2000 deactivated
2019-09-08 18:48:59	ERROR	abgblack	X2000	State of unit 'abgafrica' changed from 'WARNING' to 'ERROR'
2019-09-08 18:41:22	WARNING	abgblack	X2000	State of unit 'abgafrica' changed from 'ERROR' to 'WARNING'
2019-09-06 13:03:40	NOTICE	abgblue	StorMan	Storage System 4621347002 status changed to OK

i If you use the *Acknowledge current events* button to remove the currently displayed events from the *Current events* table, the *Events* tile reflects this change. The acknowledged events are only displayed in the *All events* tab.

i The currently possible events with messages are listed in the online help of the SE Manager under "Further information".

With the *Alarm management* you can configure automatic SNMP trap or email messages for events with certain weights and/or from certain components; this enables you to recognize important events like error situations earlier and to react quickly if necessary, even in large SE server configurations.

The SE Manager displays the alarm management configuration in the *Logging -> Alarm management* menu.

Alarm management

SNMP trap receivers

Add new trap receiver

Trap receiver	Trap community	SNMP version	Component	Weight			
<i>Filter</i>	<i>Filter</i>	<i>All</i>	<i>All</i>	<i>All</i>			
172.17.0.139	icinga	SNMPv2c	ANY	>= ERROR			
icinga.alarms.net	icinga	SNMPv2c	ANY	ANY			

Total: 2

Mail configuration

Create mail configuration

SMTP server	Return address		
imap.fujitsu.com	se-alarm-mgmt@reply.no		

Mail receivers

Add new mail receiver

Mail receivers	Component	Weight			
<i>Filter</i>	<i>All</i>	<i>All</i>			
adam.a.doe@net.com	M2000	>= ERROR			

i Security-relevant actions

Since a message can mean that sensitive data are sent to the outside, you should always thoroughly check the specified address when configuring a new SNMP trap or email receiver. Use the *Test* function to send a test trap or test email to the new receiver to see whether the message is sent to the correct receiver.

11 Related publications

You can find the following BS2000 manuals on the manual server with the BS2000 documentation at <http://bs2manuals.ts.fujitsu.com>.

Other manuals, for example descriptions of the FUJITSU PRIMERGY and PRIMEQUEST servers, can be found on the general FUJITSU manual server at <http://manuals.ts.fujitsu.com>.

- [1] **FUJITSU Server BS2000 SE Series Quick Guide**
User Guide
- [2] **FUJITSU Server BS2000 SE Series Operation and Administration**
User Guide
- [3] **FUJITSU Server BS2000 SE Series Basic Operating Manual**
- [4] **FUJITSU Server BS2000 SE Series Server Unit /390**
Operating Manual
- [5] **FUJITSU Server BS2000 SE Series Server Unit x86**
Operating Manual
- [6] **FUJITSU Server BS2000 SE Series Additive Components**
Operating Manual
- [7] **FUJITSU Server BS2000 SE Series Cluster Solutions for SE Servers**
Whitepaper

 This document is not available online. If required, Customer Support can provide you with a copy of this manual.

- [8] **BS2000 OSD/BC Introduction to System Administration (SE Server)**
User Guide
- [9] **SECOS Security Control System - Access Control**
User Guide
- [10] **SECOS Security Control System - Audit**
User Guide