

English



FUJITSU Software BS2000

ROBAR V7.5

Controlling MTC Archive Systems

User Guide

Edition December 2016

Comments... Suggestions... Corrections...

The User Documentation Department would like to know your opinion on this manual. Your feedback helps us to optimize our documentation to suit your individual needs.

Feel free to send us your comments by e-mail to:

manuals@ts.fujitsu.com

Certified documentation according to DIN EN ISO 9001:2008

To ensure a consistently high quality standard and user-friendliness, this documentation was created to meet the regulations of a quality management system which complies with the requirements of the standard DIN EN ISO 9001:2008.

cognitas. Gesellschaft für Technik-Dokumentation mbH

www.cognitas.de

Copyright and Trademarks

Copyright © 2016 Fujitsu Technology Solutions GmbH.

All rights reserved. Delivery subject to availability; right of technical modifications reserved.

All hardware and software names used are trademarks of their respective manufacturers.

Content

1	Introduction	11
1.1	Target and target groups	12
1.2	Structure of the User Guide	13
1.3	Changes since the last edition of the manual	16
1.4	Notational conventions	17
2	System components	19
2.1	ROBAR system	19
2.1.1	ROBAR-CL	20
2.1.2	ROBAR-SV	21
2.1.3	ROBAR control interfaces	23
2.1.3.1	SCSI interface	23
2.1.3.2	ABBA interface	23
2.2	Communication between the system components	24
2.2.1	Communication between ROBAR-CL and ROBAR-SV	24
2.2.2	Communication between ROBAR-SV and the archive system	25
2.3	Archive systems	26
2.3.1	Archive systems Scalar i500, i2000 and i6000 (SCSI interface)	26
2.3.1.1	Components of the archive systems	28
2.3.1.2	Terms used in the archive system	28
2.3.1.3	MTC devices and cartridges	30
2.3.2	ETERNUS CS - Virtual Tape Library (ABBA interface)	31
2.3.2.1	MTC devices and cartridges	33
2.4	Software product MAREN	34

3	Working with ROBAR	35
3.1	Operating ROBAR	36
3.1.1	Requirements for ROBAR operation	36
3.1.2	Operating ROBAR-CL	37
3.1.3	Operating ROBAR-SV	39
3.1.3.1	Roles, users and user groups of ROBAR-SV	39
3.1.3.2	ROBAR-SV instance	41
3.1.3.3	Starting a ROBAR-SV instance	42
3.1.3.4	Stopping a ROBAR-SV instance	44
3.1.4	Automating the behavior of ROBAR-SV	46
3.1.5	Controlling the execution of ROBAR-SV	48
3.1.5.1	Configuration parameters and configuration files of ROBAR-SV	48
3.1.5.2	Files for runtime control: ROBAR rule files (RRFs)	48
3.1.5.3	Multiprocessing	48
3.1.6	Obtaining information about ROBAR-SV	49
3.1.6.1	Displaying the status of the ROBAR-SV instance	49
3.1.6.2	Displaying actions of the ROBAR-SV instance	49
3.1.6.3	Trace files of the ROBAR-SV instances	50
3.1.6.4	Information on the error logging file	53
3.1.6.5	Displaying certain settings	53
3.1.7	Automatic disk storage monitoring	54
3.1.7.1	RECOVER_DISK_FULL script	54
3.1.7.2	Disk monitoring on SE servers	56
3.1.8	Managing MTC devices	57
3.1.8.1	Fixed device allocation	57
3.1.8.2	Unloading an MTC device	57
3.1.8.3	Handling MTC device errors	58
3.1.9	Working with multiple archives	59
3.1.10	Backing up and restoring ROBAR configuration files	61
3.2	Working with ROBAR (SCSI interface)	62
3.2.1	Importing and exporting cartridges	62
3.2.1.1	Importing cartridges	62
3.2.1.2	Exporting cartridges	64
3.2.2	Mounting and dismounting cartridges	66
3.2.2.1	Mounting cartridges	66
3.2.2.2	Dismounting cartridges	66
3.2.3	Device cleaning and cleaning cartridges	67
3.3	Working with ROBAR (ETERNUS CS, ABBA interface)	68
3.3.1	Mounting cartridges	68
3.3.2	Dismounting cartridges	69

3.4	Interworking of ROBAR and MAREN	70
3.4.1	Storage location management	71
3.4.1.1	Storage location	71
3.4.1.2	Preparations	72
3.4.1.3	Execution of a mount request	76
4	User interface for ROBAR-CL	79
4.1	ROBAR-CL-SDF statements	80
	ADD-ROBAR-VOLUME	
	Supply position of a foreign cartridge	81
	CREATE-ROBAR-FREEPOOL	
	Create freepool	83
	DELETE-ROBAR-FREEPOOL	
	Release task-specific freepool	86
	EXPORT-ROBAR-VOLUME	
	Export cartridges	87
	IMPORT-ROBAR-VOLUME	
	Import cartridges	90
	REMOVE-ROBAR-VOLUME	
	Release foreign cartridge	92
	SHOW-ROBAR-VOLUME	
	Displays information on foreign cartridge storing positions	93
4.2	Checking the value for the LOCATION operand	96
5	User interface for ROBAR-SV	101
5.1	Operation using the ROBAR-SV Manager	101
5.1.1	Calling the ROBAR-SV Manager	104
5.1.1.1	Calling the standalone variant (all server series)	104
5.1.1.2	Calling the add-on pack for the SE Manager (SE servers)	104
5.1.2	Logging in	106
5.1.3	Logging out	107
5.1.4	Session management	107
5.1.4.1	Session timeout (standalone variant)	107
5.1.4.2	Automatic update (standalone variant)	108
5.1.4.3	Loss of connection	108

5.1.5	ROBAR-SV Manager interface	109
5.1.5.1	Window types	109
5.1.5.2	Main window	109
5.1.5.3	The dialog	111
5.1.6	Calling an object or function in the ROBAR-SV Manager	113
5.1.7	Navigation	114
5.1.8	Filtering a table	114
5.1.9	Sorting a table	115
5.1.10	Executing an action	115
5.1.11	Calling the online help	116
5.1.12	Error handling	117
5.2	Controlling ROBAR operation using the ROBAR-SV Manager	118
5.2.1	Overview of tasks	118
5.2.2	Displaying information on ROBAR-SV instances	122
5.2.3	Creating and deleting ROBAR-SV instances	123
5.2.3.1	Uploading a configuration file	123
5.2.3.2	Creating a new instance	123
5.2.3.3	Displaying an instance's configuration file	123
5.2.3.4	Deleting an instance	124
5.2.4	Operating a ROBAR-SV instance	125
5.2.4.1	Starting, restarting, resetting, or stopping an instance	126
5.2.4.2	Editing the instance's configuration file	126
5.2.4.3	Downloading the instance's configuration file	126
5.2.4.4	Uploading the instance's configuration file	127
5.2.4.5	Checking the configuration file	127
5.2.4.6	Enabling and disabling automatic restart	127
5.2.4.7	Manual entry of archive system commands	128
5.2.4.8	Editing the ROBAR rule files	128
5.2.4.9	Calling the "robar" menu program for the selected instance	130
5.2.5	Displaying the status of the BS2000 systems and of the archive system	131
5.2.5.1	Displaying the Archive number ranges	132
5.2.6	Displaying information on messages and devices	133
5.2.7	Editing logging files of ROBAR-SV instances	134
5.2.7.1	Displaying the instance's logging file	135
5.2.7.2	Downloading the instance's logging file	135
5.2.7.3	Removing the instance's logging file	135
5.2.8	Diagnostic information on the ROBAR-SV instance	136
5.2.8.1	Collecting current diagnostic data	137
5.2.8.2	Editing diagnostic data	137
5.2.8.3	Displaying device and volume error	138
5.2.8.4	Editing error information for devices and volumes	138
5.2.8.5	Outputting ROBAR statistics	138
5.2.9	Displaying information on the users of ROBAR-SV	139

- 5.2.10 Displaying information on the ROBAR server 139
- 5.2.11 Managing global configuration of the ROBAR server 140
 - 5.2.11.1 Editing the global configuration file of the ROBAR server 141
 - 5.2.11.2 Backing up and restoring ROBAR configuration files 142
 - 5.2.11.3 Setting the automatic update on a user-specific basis 143
 - 5.2.11.4 Setting the session timeout value on a user-specific basis 143
- 5.2.12 Managing the partner configuration (CMX) of the ROBAR server 144
 - 5.2.12.1 Add a new partner 145
 - 5.2.12.2 Deleting or changing partner data 145
 - 5.2.12.3 Add a new local name 145
 - 5.2.12.4 Deleting or changing a local name 146
- 5.2.13 Creating and managing links to external devices and websites 147
- 5.3 Operation using the “robar” menu program 148**
 - 5.3.1 User groups and functional scope 148
 - 5.3.2 Screen layout 150
- 5.4 Controlling ROBAR operation using the “robar” menu program 151**
 - DEFINES
 - Manage ROBAR rule files 152
 - DISPLAY
 - Monitor ROBAR actions 154
 - EXIT
 - Terminate “robar” menu program 158
 - FREEPOOL
 - Manage ROBAR standard freepool 159
 - INSTANCES
 - Manage ROBAR-SV instances 162
 - LIST
 - Obtain information on trace files and archive number ranges 165
 - MANUAL
 - Enter archive system commands manually 171
 - REPAIR
 - Manage error information 177
 - SAVE
 - Save diagnostic data 179
 - START
 - Start ROBAR-SV instance. 180
 - STOP
 - Terminate ROBAR-SV instance 182
- 5.5 Ignoring obsolete messages (DISCARD_MSG) 183**

6	Installation and configuration	185
6.1	Installing ROBAR-CL	185
6.2	Configuring ROBAR-CL	187
6.2.1	Modifying the start file for ROBAR-CL-DCAM	188
6.2.2	ROBAR-CL as an authorized user program	191
6.3	Connection of ROBAR-CL, ROBAR-SV, and the archive system	193
6.3.1	Connection from the BS2000 system to the ROBAR server	193
6.3.2	Connection from the ROBAR server to the archive system	194
6.3.2.1	Connections at the SCSI interface	194
6.3.2.2	Configuring archive systems with a SCSI interface	197
6.3.2.3	Connections at the ABBA interface	197
6.3.2.4	Configuring archive systems with an ABBA interface	197
6.4	Installing ROBAR-SV	198
6.4.1	Installation using YaST	199
6.4.2	Directories and files of ROBAR-SV	202
6.4.3	Uninstallation	206
6.5	Configuring ROBAR-SV	209
6.5.1	Users of ROBAR-SV	209
6.5.2	Global configuration file for ROBAR-SV	210
6.5.3	Interface-specific ROBAR-SV configuration files	212
6.5.3.1	Creating a new configuration file for a ROBAR-SV instance	212
6.5.3.2	Migrating an existing configuration file	213
6.5.3.3	Information on adjusting the interface-specific configuration file	214
6.5.3.4	Sample of the interface-specific configuration file (SCSI interface)	215
6.5.3.5	Sample of the interface-specific configuration file (ABBA interface)	227
6.5.4	Generation of names for CMX	238
6.5.5	Multiprocessing	240
6.5.6	Configuration variants	243
6.5.6.1	Installing ROBAR-SV in a uniform configuration	243
6.5.6.2	ROBAR-SV in the case of multiple configuration	243
6.5.6.3	Installing storage locations	243
6.6	Upgrading from previous ROBAR versions	244

7	ROBAR rule files	247
7.1	Interrelationships between the files	249
7.1.1	BS2000 message - message_file	249
7.1.2	message_file - message_xref	249
7.1.3	message_xref - roboter_cmds/message_resp	250
7.1.4	Overview	252
7.2	Description of the files	253
7.2.1	File SYSPAR.ROBAR-CL.<ver>.MESSAGES	255
7.2.2	File SYSPAR.ROBAR-CL.<ver>.PROZPARAM	259
7.2.3	File message_file	260
7.2.4	File message_xref	268
7.2.5	File message_resp	273
7.2.6	File roboter_cmds	304
7.2.7	File error_defines	307
7.3	ROBAR rule files for ETERNUS CS	310
7.4	Modifications in the ROBAR rule files	311
8	Messages	315
8.1	ROBAR-SV messages	315
8.2	BS2000 messages	315
9	Troubleshooting	317
9.1	Device and volume error counters	318
9.2	Robot failure	323
9.3	Severance of the connection between ROBAR-SV and BS2000	324
9.4	Failure of the ROBAR server	324
9.5	Defective MTC devices	325
9.6	Input/output area overflow during cartridge transfer	326
9.7	Preparing documents for diagnosis	327
9.7.1	Diagnostic documentation for a BS2000 system	327
9.7.2	Diagnostic documentation for the ROBAR server	328
9.7.3	Problems with the TCP/IP connection (ABBA interface)	329

10	Appendix	331
10.1	ROBAR-CL trace file	331
10.2	ROBAR-SV trace files	332
10.2.1	robar.trace	332
10.2.2	vbs2.trace	337
10.2.3	nbs2.trace	339
10.3	ROBAR statistics	341
10.3.1	Summary statistics	341
10.3.2	Host statistics	343
10.3.3	Statistics on manual inputs	345
10.3.4	Cleaning statistics	346
10.3.5	IMPORT/EXPORT statistics	347
10.3.6	Inventory statistics	348
10.3.7	Error statistics	349
	Glossary	351
	Related publications	355
	Index	357

1 Introduction

The software product **ROBAR** (**RO**Bot **AR**chive) controls and automates the operation of MTC archive systems which are operated by robots.

ROBAR V7.5 controls the following MTC archive systems:

- the ETERNUS CS virtual archive system from Fujitsu Ltd.
- the real archive systems Scalar from Quantum Corp.

The term archive system is used for all MTC archive systems run with ROBAR, if no further distinction of the archive systems is required.

The archive systems are controlled and automated by linking the BS2000 system, the ROBAR server and the archive system.

ROBAR-SV manages communication and coordination between the BS2000 systems and the archive system on the ROBAR server.

ROBAR acts as the job submitter for the archive system.

As many as 110 BS2000 systems (including guest systems under VM2000) and as many as 1024 MTC devices for an archive system can be controlled with ROBAR.

ROBAR consists of the ROBAR-CL and ROBAR-SV software components which must both be run together:

- ROBAR-CL (decentralized ROBAR part on the BS2000 system) is the local BS2000 connection component between BS2000 and ROBAR-SV on the ROBAR server. This is where messages concerning the MTCs are filtered from the UCON console message stream and passed on to ROBAR-SV. For ROBAR-SV, these messages are the basis on which the archive system is controlled.
- ROBAR-SV (central ROBAR part on the ROBAR server) connects ROBAR-CL and the archive system. ROBAR-SV receives the requests issued by ROBAR-CL (in the form of messages), evaluates them and passes them on to the archive system. ROBAR-SV runs on a separate server which is called the ROBAR server. Other software products which are independent of ROBAR can also run on the ROBAR server.

In the sense of a client/server architecture ROBAR-CL is the client part and ROBAR-SV the server part of ROBAR.

Since it is closely linked with other BS2000 software products (such as MAREN, HSMS/ARCHIVE), tape processing can be optimally organized with ROBAR.

All version dependencies are described in the ROBAR Release Notice.
The hardware and software dependencies of ROBAR are also described there.

1.1 Target and target groups

This manual is intended for system administrators.

It describes the functional scope and mode of operation of the software product ROBAR that controls automatic sequences in the MTC archive system.

To fully understand this manual you will need to be familiar with the BS2000 and Linux operating systems.

For BS2000 we recommend that you read the manuals dealing with the BS2000 basic configuration, in particular the manuals "System Installation" [4] and the "Introduction to System Administration" [2]. You should also familiarize yourself with the BS2000 command language SDF, since the user interface, screen layout and prompting of ROBAR-CL in BS2000 all use SDF. SDF is described in the manual "SDF Dialog Interface" [9].

For Linux, you will need to know how to use the operating system. For an introduction we recommend that you read the Linux manuals, especially the "Administration Guide" [16].

For installation you require system administration skills. The manuals recommended for this purpose depend on the server used (see the relevant operating manuals) and on the operating system used (BS2000 or Linux). The "Operation and Administration" manual [14] is recommended specifically for SE servers.

For communication you require a knowledge of the software product CMX. This is provided by the manual "CMX Communication Manager" [12, 13].

You will find a detailed description of ETERNUS CS in the ETERNUS CS manual [11] (the exact title depends on the version).

For information on the Scalar archive systems you are referred to the documentation of the manufacturer ([15]).

You will find detailed information on required versions of software products and of supported devices in the release notice of ROBAR.

1.2 Structure of the User Guide

The introductory [chapter “System components”](#) and the chapter [“Working with ROBAR”](#) are fundamental for understanding ROBAR, its system components and how they interwork. The archive-system-specific sections contain the information which is relevant specifically for the operators of the particular archive systems.

The reference chapters [“chapter “User interface for ROBAR-CL””](#) and [“User interface for ROBAR-SV”](#) contain, in alphabetical order, the statements to the user program ROBAR-CL-SDF, the menus of the ROBAR-SV Manager and the menus of the `robar` menu program. Archive-system-specific information has been added at the relevant places in these chapters.

The [chapter “Installation and configuration”](#) provides information on installing and configuring ROBAR-CL in BS2000 and ROBAR-SV on the ROBAR server. This chapter, which is intended for specialists, provides a large amount of archive-system- and operating-system-specific information.

Information for specialists who have a thorough knowledge of the ROBAR system is contained in the chapters [“Troubleshooting”](#), [“ROBAR rule files”](#), [“Messages”](#) and [“Appendix”](#).

At the back of the manual you will find a glossary, a list of related publications, and an index.

Reader’s guideline for users with the ETERNUS CS virtual archive system

- Inform yourself about ROBAR in the following sections:
 - [2.1 ROBAR system](#)
 - [2.2 Communication between the system components](#)
 - [2.3.1 ETERNUS CS - Virtual Tape Library \(ABBA interface\)](#)
 - [2.4 Software product MAREN](#)
- Learn about working with ROBAR in the following sections:
 - [3.1 Operating ROBAR](#)
 - [3.2 Working with ROBAR \(ETERNUS CS, ABBA interface\)](#)
 - [3.4 Interworking of ROBAR and MAREN](#)

- Install ROBAR with the help of the following sections:
 - 6.1 Installing ROBAR-CL
 - 6.2 Configuring ROBAR-CL
 - 6.3.2.1 Connections at the ABBA interface
 - 6.4 Installing ROBAR-SV
 - 6.5 Configuring ROBAR-SV, especially
 - 6.5.3.4 Sample of the interface-specific configuration file (ABBA interface)

In the other chapters you will find detailed information on using ROBAR which you require for operating ROBAR. Information which applies specifically for the ETERNUS CS virtual archive system is indicated by **ABBA interface**.

Reader's guideline for users with the Scalar i500, i2000 and i6000 archive systems

- Inform yourself about ROBAR in the following sections:
 - 2.1 ROBAR system
 - 2.2 Communication between the system components
 - 2.3.1 Archive systems Scalar i500, i2000 and i6000 (SCSI interface)
 - 2.4 Software product MAREN
- Learn about working with ROBAR in the following sections:
 - 3.1 Operating ROBAR
 - 3.2 Working with ROBAR (SCSI interface)
 - 3.4 Interworking of ROBAR and MAREN
- Install ROBAR with the help of the following sections:
 - 6.1 Installing ROBAR-CL
 - 6.2 Configuring ROBAR-CL
 - 6.3.2.1 Connections at the SCSI interface
 - 6.3.2.2 Configuring archive systems with a SCSI interface
 - 6.4 Installing ROBAR-SV
 - 6.5 Configuring ROBAR-SV, especially
 - 6.5.3.4 Sample of the interface-specific configuration file (SCSI interface)

In the other chapters you will find detailed information on using ROBAR which you require for operating ROBAR. Information which applies specifically for the Scalar i500, i2000 and i6000 archive systems is indicated by **SCSI interface**.

Readme file

The functional changes to the current product version and revisions to this manual are described in the product-specific Readme file.

Readme files are available to you online in addition to the product manuals under the various products at <http://manuals.ts.fujitsu.com>. You will also find the Readme files on the Softbook DVD.

Information under BS2000

When a Readme file exists for a product version, you will find the following file on the BS2000 system:

```
SYSRME.<product>.<version>.<lang>
```

This file contains brief information on the Readme file in English or German (<lang>=E/D). You can view this information on screen using the `SHOW-FILE` command or an editor. The `/SHOW-INSTALLATION-PATH INSTALLATION-UNIT=<product>` command shows the user ID under which the product's files are stored.

Additional product information

Current information, version and hardware dependencies, and instructions for installing and using a product version are contained in the associated Release Notice. These Release Notice are available online at <http://manuals.ts.fujitsu.com>.

1.3 Changes since the last edition of the manual

Software configuration

ROBAR V7.5 can execute on the current BS2000 servers under BS2000.

The server, firmware, tape device and version dependencies and information on resource utilization can be found in the ROBAR Release Notice.

ROBAR requires the software product MAREN to use the virtual archive system ETERNUS CS and archive system with storage location management. The version dependencies are described in the ROBAR Release Notice.

Important changes to the “ROBAR” manual

- The Scalar 10K archive system is no longer supported. Its description and the description of related functions and statements in ROBAR-CL-SDF have been deleted from this manual.
- New configuration parameter `INIT_RESTART_OPTION` in the interface-specific configuration files of ROBAR-SV.
- Changes in the ROBAR-SV Manager
 - Direct selection of tabs using tool tips in the objects and functions.
 - The range of VSNs is now displayed in the *BS2000 hosts & Library* tab.
 - In the *Operation* tab a distinction is made between operating actions and configuration actions. Instances can also be restarted and reset.
 - In the *BS2000 hosts & Library* tab the BS2000 host status has been supplemented by additional information.
 - The logging files are sorted according to their start date - from youngest to oldest.
 - The size of the dialog window for the display and edit functions can be set.
 - The display and edit functions for ROBAR rule files and logging files have colored markings.
 - When a CMX partner is created, you can define whether or not ROBAR is to generate an associated local name automatically.
- Installation and audit logging information for the ROBAR-SV Manager is displayed in the SE Manager if the ROBAR-SV Manager is installed as an add-on pack.

1.4 Notational conventions

The following abbreviations are used throughout this manual:

- The FUJITSU Servers BS2000 SE Series are referred to as SE servers for short.
- The server on which ROBAR-SV runs is simply called the **ROBAR server**.
- The term **archive system** is used for all MTC archive systems operated using ROBAR if no further distinction of the archive systems is required.
- The abbreviations `<interface>` and `<instance>` refer to the current name of a ROBAR interface (ABBA, SCSI) and of a ROBAR-SV instance, e.g. in the file name `ROBAR-SV.<interface>_<instance>.<file>.<timestamp>.tar`.
- The abbreviation `<ver>` refers to the current version of a ROBAR component, e.g. in the file name `SYSPRC.ROBAR-CL.<ver>`. The value `075` applies in this version of ROBAR.
- In the examples the strings `<date>`, `<time>` and `<version>` refer to the current outputs for date, time and version when the examples are otherwise independent of date, time and version.

In this manual, the following terms are used synonymously:

- magnetic tape cartridge = cartridge = MTC
- magnetic tape cartridge archive system = MTC archive system = archive system
- archive number = VSN (Volume Serial Number)
- ROBAR system = ROBAR V7.5 = ROBAR
- ROBAR-SV administrator = ROBAR administrator
- ROBAR-SV operator = ROBAR operator
- Unless any finer distinction is made, the term ETERNUS CS is used in this manual for all previous product names of ETERNUS CS: ETERNUS CS8000 (V6.0 SP1 and higher), ETERNUS CS HE (V5.0 and V5.1).

The following typographical elements are used in this manual:

`TRACE_LIMIT` Examples as well as directories, filenames, menus, messages, parameters or variables are printed in `typewriter` face.



For notes on particularly important information

References to other publications within the text are given in abbreviated form followed by a number in square brackets. The full titles are listed in the “References” section.

2 System components

The software product **ROBAR** (**RO**Bot **AR**chive) controls and automates the operation of MTC archive systems which are operated by robots.

The following system components are required:

- ROBAR system
- MTC archive system

2.1 ROBAR system

As the interface between the BS2000 systems and the archive system, ROBAR controls virtual or real archive systems in a multisystem environment with up to 110 BS2000 systems and as many as 1024 MTC devices (real or virtual) for an archive system. Each guest system under VM2000 counts as an autonomous BS2000 system.

Each BS2000 system can access the full functional scope of the archive system and, in terms of the devices offered by the archive system, is of equal status as regards the submission of jobs. ROBAR acts as the job submitter for the archive system. Cross-server communication and coordination between the BS2000 systems and the archive system is handled by means of ROBAR-SV on the ROBAR server.

ROBAR controls the archive systems on a hardware-dependent basis via the SCSI or ABBA interface, see [section “ROBAR control interfaces” on page 23](#).

ROBAR comprises the following software components, which can only execute together:

- ROBAR-CL (decentralized ROBAR part on the BS2000 system)
- ROBAR-SV (central ROBAR part on the ROBAR server)

In the sense of a client/server architecture ROBAR-CL is the client part and ROBAR-SV the server part of ROBAR.

2.1.1 ROBAR-CL

ROBAR-CL is the component for linking a BS2000 system and ROBAR-SV on the ROBAR server. ROBAR-CL processes, for example, the primary mounting and dismounting jobs involved in cartridge handling which are submitted by BS2000.

ROBAR-CL comprises of the following components:

- DCAM application ROBAR-CL-DCAM (cartridge mount and dismount requests)
Cartridge mount and dismount requests are submitted by all tape-processing programs (e.g. HSMS/ARCHIVE, MAREN and INIT).
ROBAR-CL-DCAM is a process which has UCON authorization.
When a job submitter sends its requests to the operator console (“Console” interface), then ROBAR-CL-DCAM filters the messages from the UCON console message stream which are relevant to MTCs and passes them (in abbreviated form) to ROBAR-SV. For ROBAR-SV, these messages are the basis on which the archive system is controlled.
- ROBAR-CL-SDF user program (organizational tasks)
Statements for the organization of cartridges are required for optimum utilization of the archive system. These organizational statements (e.g. importing/exporting of cartridges on a system and user-specific basis) are processed via the ROBAR-CL-SDF user program.
ROBAR-CL-SDF sends its requests to the operator console (“Console” interface), where they are handled by ROBAR-CL-DCAM as requests from tape-processing programs.

2.1.2 ROBAR-SV

ROBAR-SV runs on a separate server which is called the ROBAR server. Other software products which are independent of ROBAR can also run on the ROBAR server.

ROBAR-SV is the connection component between ROBAR-CL and the archive system. ROBAR-SV also monitors the connection between ROBAR-CL and the archive system in both directions.

ROBAR-SV has transmit and receive functions to the BS2000 systems. Access to archive systems by BS2000 (guest) systems is coordinated here.

The “message interpreter” is the central function of ROBAR-SV. It interprets and coordinates the messages received from ROBAR-CL, converts them to standardized commands (action calls), and uses them to control the archive system or has them executed by the BS2000 system.

The following are examples of message interpreter action calls:

- Actions for execution in the archive system, e.g. mounting a cartridge
- Actions for execution in the BS2000 system, e.g. replying to a message

Actions for execution in the archive system are passed on to the archive system connected to the ROBAR server. The action call type is controlled via the so-called “ROBAR rule files”. ROBAR rule files (RRFs) are files for execution control that define messages for which specific actions should be undertaken by the archive system.

The ROBAR operator can modify the default settings for the message interpreter to suit requirements, see [chapter “ROBAR rule files” on page 247](#). Such changes can be integrated dynamically during ongoing operation.

Actions for execution in the BS2000 system are conveyed to the operating system or to ROBAR-CL-SDF via the console interface.

ROBAR-SV offers the following information and functions via menu-driven user interfaces:

- managing the archive systems
- managing ROBAR-SV instances and their components
- status information on ROBAR-SV instances and archive systems
- information on messages and devices of ROBAR-SV instances
- creating diagnostic information and statistics concerning ROBAR-SV instances
- information on the users of ROBAR-SV
- information on the ROBAR server
- Managing the global and CMX configurations of the ROBAR server
- processing of scratch cartridges using a tape management facility other than MAREN
- logging of all actions executed by ROBAR-SV in trace files

2.1.3 ROBAR control interfaces

ROBAR controls the archive systems on a hardware-dependent basis via the so-called SCSI interface or via the so-called ABBA interface. These two interfaces are fundamentally different from each other. They are also implemented in ROBAR using different program modules.

2.1.3.1 SCSI interface

The SCSI interface defines the design of ROBAR operation for the real archive systems Scalar i500, Scalar i2000 and Scalar i6000 from Quantum Corp.

Connection of the archive systems

The archive systems with SCSI interface are connected to the ROBAR server via a Storage Area Network (SAN) of the type "fabric". The robotics of the archive system is controlled via fibre channel (FC).

Devices

LTO-Ux.

Media management

The media management of the archive system is embedded in ROBAR. Partitions can be created in the archive system. A separate instance of ROBAR-SV is required on the ROBAR server for each partition.

2.1.3.2 ABBA interface

The ABBA interface defines the design of ROBAR operation for the virtual archive system ETERNUS CS.

Connection of the archive systems

The virtual archive system ETERNUS CS is connected to the ROBAR server by means of a TCP/IP connection.

Devices

Devices 3590E and LTO-Ux.

Media management

The media management resides in the archive system.

2.2 Communication between the system components

Device and volume reservation is the responsibility of the BS2000 systems. All requests for devices and volumes from system and user processes are handled by BS2000 device management and result in mount or dismount messages at the console, which are then processed by ROBAR.

2.2.1 Communication between ROBAR-CL and ROBAR-SV

The physical connection from the BS2000 system to the ROBAR server is implemented using a LAN or WAN, see [page 193](#).

The status of the connection between ROBAR-CL and ROBAR-SV can be monitored in the BS2000 system using a job variable, see [page 37](#). In the ROBAR-SV Manager this information is displayed for all ROBAR-SV instances in the overview window (see [page 122](#)) and on an instance-specific basis in the menu of a ROBAR-SV instance (see [page 125](#)). When the connection is interrupted, this is displayed both on the pages of the ROBAR-SV Manager and in the menu window of the `robar` menu program of ROBAR-SV (see [page 148](#)).

ROBAR-CL-DCAM must be started on every BS2000 system which is connected to the ROBAR server using the start procedure `SYSPRC.ROBAR-CL.<ver>` (by means of `ENTER-PROCEDURE` or `CALL-PROCEDURE`, see [page 37](#)).

During connection setup for ROBAR-SV and ROBAR-CL-DCAM, ROBAR-SV transfers a list of the supported devices and of the error codes which are relevant (inserts of message `EXC0858`) to ROBAR-CL.

During ongoing operation UCON forwards the console messages with the routing codes which are relevant for MTC operation to ROBAR-CL-DCAM. You define these routing codes when ROBAR-CL is configured, see [page 191](#).

ROBAR-CL-DCAM filters out those messages which are relevant for ROBAR-SV (see [section "File SYSPAR.ROBAR-CL.<ver>.MESSAGES" on page 255](#)).

From the messages containing the insert `MN` (mnemonic device name) and from the `EXC0858` messages only those are forwarded which are relevant for ROBAR-SV.

Jobs from the ROBAR-CL-SDF user program are also passed to ROBAR-CL-DCAM via the console interface.

2.2.2 Communication between ROBAR-SV and the archive system

The physical connection between the ROBAR server and the archive system for controlling the robotics in the archive system is hardware-dependent:

- Archive systems with a SCSI interface are connected via fibre channel (FC), see [page 194](#)
- Archive systems with an ABBA interface have a TCP/IP connection, see [page 197](#)

`robar_abba` runs as a central process on the ROBAR server. It is started when a ROBAR-SV instance is started. Up to ten `robar_abba` processes per archive system can be started when using multiprocessing.

Each of these processes reads a message from the job file and then performs the actions associated with this message number. These are generally actions to be executed in the archive system, such as mounting a cartridge, or actions to be executed in the BS2000 system, such as responding to a message. The actions to be executed in the archive system are transferred to the archive system, executed there and acknowledged.

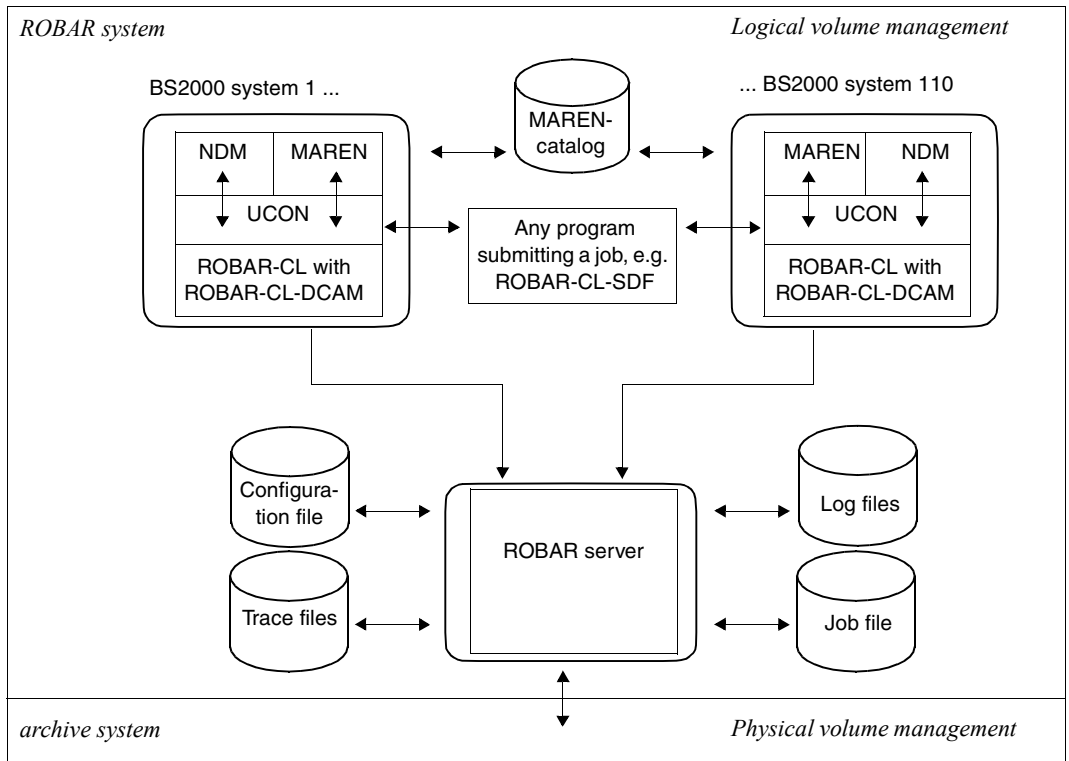

Figure 1: Communication between the system components

2.3 Archive systems

A real archive system consists of a specific number of MTC devices, a controller and hardware-dependent connections to the BS2000 system. The real MTC systems are operated by the robot.

In a virtual archive system the real archive system is preceded by an archive system with virtual devices and volumes.

2.3.1 Archive systems Scalar i500, i2000 and i6000 (SCSI interface)

The real archive systems Scalar i500, i2000 and i6000 belong to the current product range of Quantum Corp. Detailed information can be found in the manufacturer's documentation [15].

They are closed archive systems, connected via SAN (Storage Area Network) and Fibre Channel, which execute requests for mounting and dismounting cartridges fully automatically, as they do requests for archiving the cartridges. The archive systems can be extended on a variable basis.

The archive systems consist of the components cartridge storage system and input/output unit. An overview of the components is provided in [figure 2 on page 27](#).

The (real) MTC devices are operated by the robot and administered by the BS2000 systems. The MTC devices are reserved by the BS2000 systems. The BS2000 system has direct and exclusive access to the MTC device here.

These archive systems can also be administered directly in ROBAR operation over the Internet when the IP address is specified. The Scalar i2000 and i6000 archive systems can also be monitored and administered locally or remotely via the Library Management Console (LMC). The LMC is accessed remotely via the client instance of the Management Console (AMC).



The functions for making changes to the data stored (Import, Export, Move Media) which are offered at the administration interface of the archive systems may not be used in ongoing ROBAR operation.

ROBAR controls these archive systems via the SCSI interface, see [page 23](#).

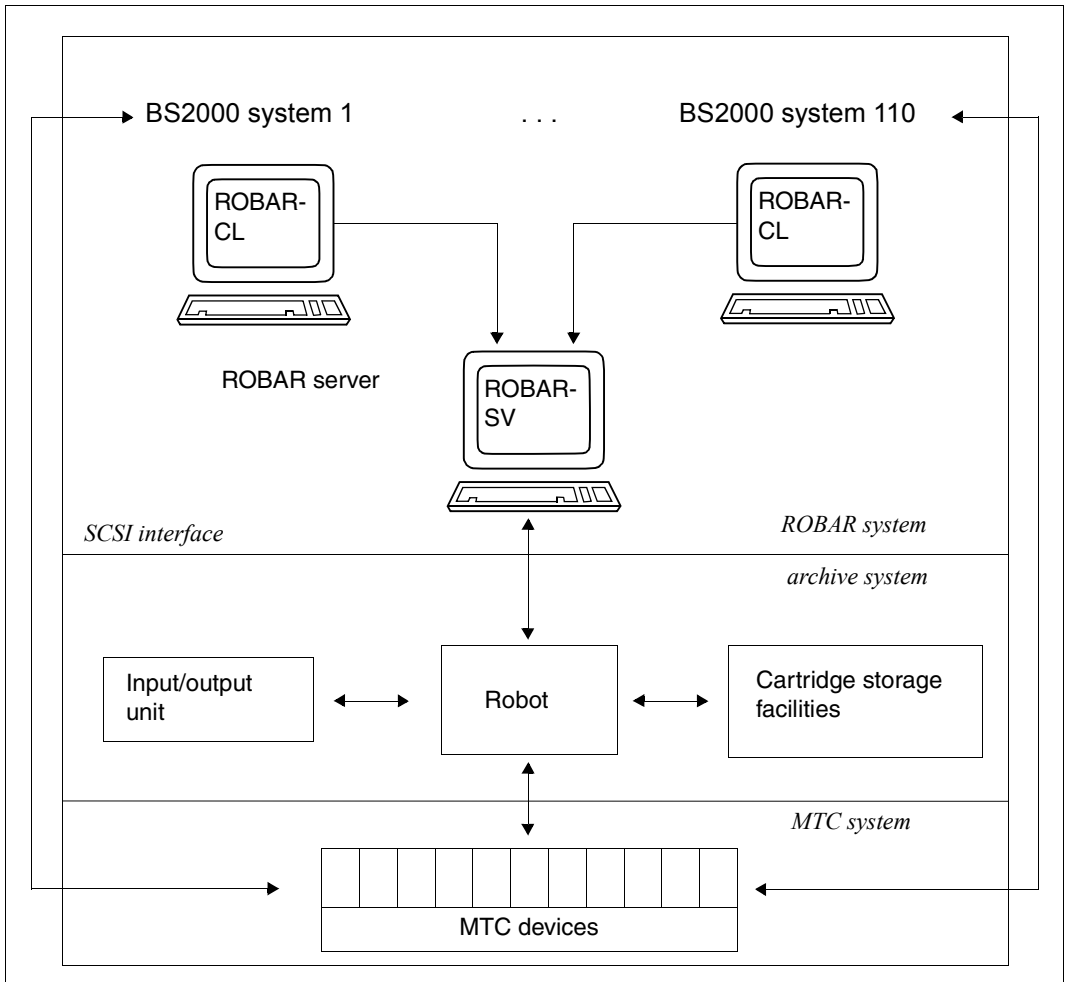

Figure 2: System components for the archive systems Scalar i500, i2000 and i6000

2.3.1.1 Components of the archive systems

Cartridge storage systems

The archive system deposits a cartridge at any storage location which it knows. For recognition purposes, the cartridges bear machine-readable barcode labels.

Input/output unit

The archive systems provide robot-operated input/output units so that cartridges can be passed to or removed from the closed archive system.

The design and usage of the input/output unit differ for the archive systems:

- The **Scalar i500** archive system has one input/output unit which is used by all partitions of the archive system.
- In the **Scalar i2000** and **i6000** archive systems each input/output unit is assigned to a particular partition of the archive system.

These differences must be taken into account when cartridges are imported and exported, see the notes in [section "Importing and exporting cartridges" on page 62](#).

2.3.1.2 Terms used in the archive system

Archive numbers

Each cartridge has a 6-digit archive number under which it is known in the archive system. This number must be identical with the volume serial number (VSN) with which the cartridge was initialized in the BS2000 system. The VSN is the identifier by which the cartridge is known to the BS2000 system. In this manual the terms "archive number" and "VSN" are used synonymously. "Archive number" may not be confused with the "number of the archive". (see [page 60](#)).

Archive organization

Each cartridge must carry a barcode label bearing the relevant VSN. The barcode label must be unique within the archive.

The archive system deposits a cartridge at any storage location which it knows. The storage location is entered in the archive record by ROBAR-SV.

Archive record (archive database)

The archive record is a database of ROBAR-SV for the archive systems which are controlled by ROBAR via the SCSI interface.

At every startup ROBAR checks the status of the archive system and creates a new archive record. The archive record contains information on the cartridge storage locations and the available cartridges. While it is running ROBAR-SV maintains the archive record exclusively in the main memory.

ROBAR has no information function of its own via the archive record. An overview of the cartridges and storage locations is offered by the archive system's administration interface (see [page 26](#) and the manufacturer's documentation ([15])).

Initial stocking of cartridges in the archive

Depending on the size of the archive, initial cartridge stocking is carried out either manually or automatically.

The cartridges must have a barcode label bearing the relevant VSN. But they need not be initialized. The user is free to decide on the VSNs. It is not necessary to place the cartridges in the order of their VSNs.

For information on cleaning cartridges see [section "Device cleaning and cleaning cartridges" on page 67](#).

Partition

Partitions of a Scalar i500, i2000 or i6000 archive system are subdivisions of the real archive system into multiple logical archive systems. Each partition (each logical archive system) separates the applications running there, the connections to a server system and the data used from other partitions.

Consequently you can control precisely one partition exclusively in a real Scalar i500, i2000 or i6000 archive system with one ROBAR-SV instance.

Only cartridges with unique VSNs may be located in a partition of the archive system because ROBAR-SV always uses the first VSN found in the archive record for requests.

2.3.1.3 MTC devices and cartridges

Each real MTC device to be operated must be defined in the interface-specific ROBAR-SV configuration file (see [page 212](#)).

From the point of view of the BS2000 system, an MTC device is identified by its mnemonic device name and its device type. The following device types are supported by ROBAR at the SCSI interface:

BS2000		Device feature	type in the configuration file	RRF_dir
Device type	Type code			
LTO-U2 ¹	CC	512-track MTC	TAPE-U2	TYPE-1
LTO-U3	CD	640-track MTC	TAPE-U3	TYPE-1
LTO-U4	CE	896-track MTC	TAPE-U4	TYPE-1
LTO-U5	CF	1280-track MTC	TAPE-U5	TYPE-1
LTO-U6	D1	2176-track MTC	TAPE-U6	TYPE-1

¹ not Scalar i500

Only the cartridges released for a specific MTC device type can be used.

Each device type is assigned an appropriate ROBAR rule file (see [chapter “ROBAR rule files” on page 247](#)).

MTC device reservation by and allocation to the BS2000 systems is the responsibility of the BS2000 device management facility.

Further information is provided in [section “Managing MTC devices” on page 57](#).

2.3.2 ETERNUS CS - Virtual Tape Library (ABBA interface)

ETERNUS CS is the virtual archive system provided by Fujitsu.

With ETERNUS CS, a virtual archive system is inserted ahead of the real archive system with the real MTC devices and volumes. The virtual archive system contains a number of virtual devices and volumes. The core of ETERNUS CS is a disk system in the form of a data cache. This not only ensures extremely high-speed access to the data, but, thanks to the large number of virtual drives and logical volumes, existing bottlenecks in a real tape robot system are eliminated.

From the point of view of its connected BS2000 systems, ETERNUS CS acts as a real archive system with MTC devices of type 3590E and LTO-4. It buffers logical volumes on a RAID disk system. Under the control of the Library Manager, these volumes are backed up in a real archive system. Data is restored by means of the reverse process, where the real robot of the archive system is only called on to act if the volumes are no longer present on the disk.

For more detailed information on the virtual archive system, read the manual “ETERNUS CS HE” [11].

The configuration parameters and settings recommended in the manual and in the ETERNUS CS Release Notice should be employed when using ETERNUS CS.

ROBAR controls the virtual archive system ETERNUS CS, but not the real archive system downstream of it. The ETERNUS CS software manages the real archive system with its MTC devices and volumes.

ROBAR controls ETERNUS CS with its virtual MTC devices via the ABBA interface (see [page 23](#)) using a special, autonomous ROBAR rule file. The archive record consists of the databases of the ETERNUS CS software.

ROBAR is the communication interface between the BS2000 system and ETERNUS CS. The BS2000 systems reserve the virtual MTC devices. A BS2000 system has direct and exclusive access **only** to the virtual MTC device. Robots operate the real MTC devices. ETERNUS CS provides the data.

An overview of the components is provided in [figure 3 on page 32](#).

ROBAR messages and indications still generally relate to a real archive system. The message `ROB9802` indicates a problem within ETERNUS CS.

The term archive system means a virtual archive system when relating to ETERNUS CS. In ETERNUS CS, AMU means the virtual AMU (VAMU).

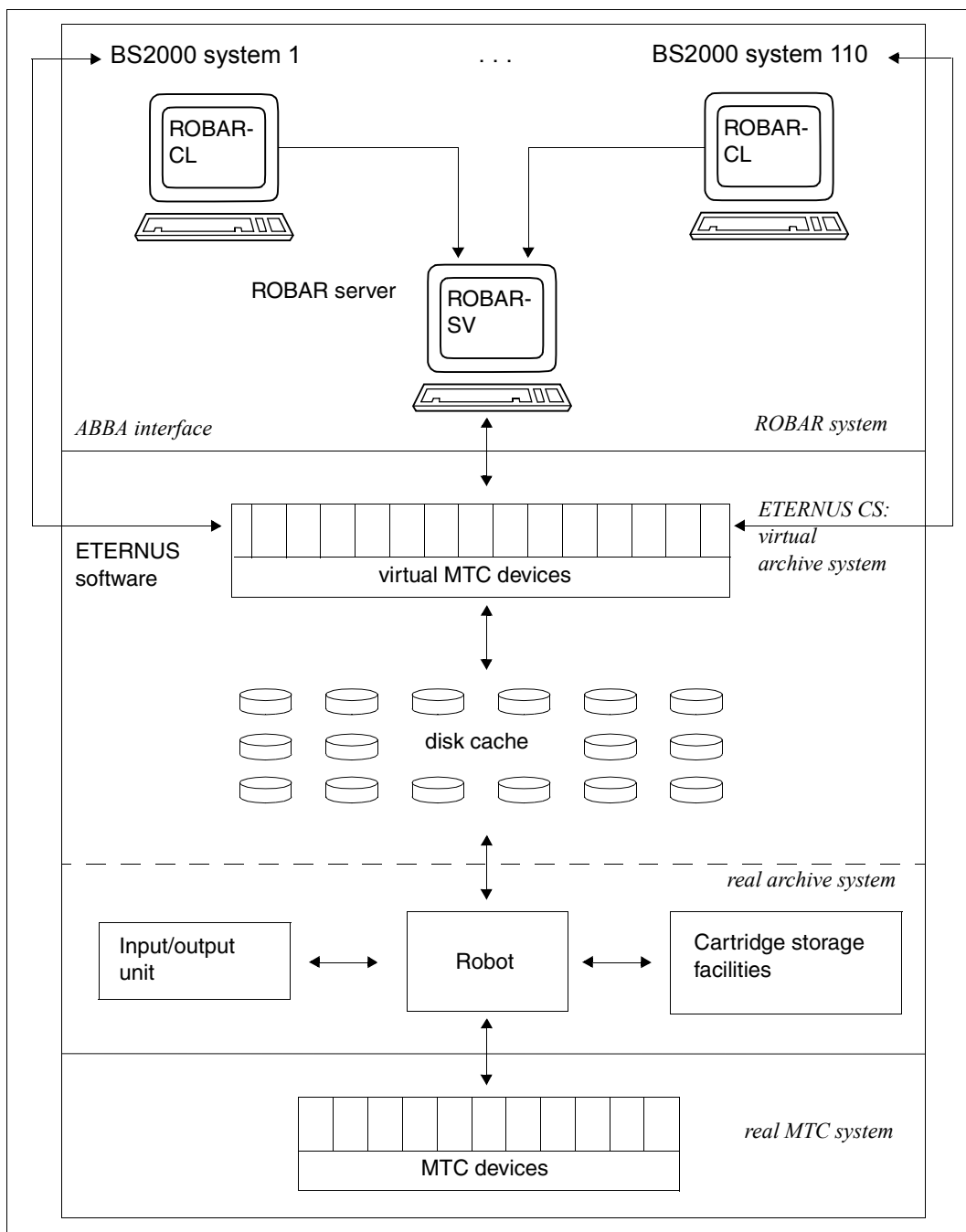

Figure 3: System components for the virtual archive system ETERNUS CS

2.3.2.1 MTC devices and cartridges

Each virtual MTC device to be operated must be defined in the interface-specific ROBAR-SV configuration file (see [page 212](#)).

From the point of view of the BS2000 system, an MTC device is identified by its mnemonic device name and its device type.

The following device types are supported for ETERNUS CS:

BS2000		Device feature	type	RRF_dir in the configuration file
Device type	Type code			
3590E	C4	Virtual device in ETERNUS CS	TAPE-C4	Automatic allocation by ROBAR installation
LTO-U4	CE	Emulated device in ETERNUS CS	TAPE-U4	Automatic allocation by ROBAR installation

Operation of ETERNUS CS requires a special ROBAR rule file (see [page 310](#)).

MTC device reservation by and allocation to the BS2000 systems is the responsibility of the BS2000 device management facility.

Further information is provided in [section “Managing MTC devices” on page 57](#).

2.4 Software product MAREN

The use of ROBAR together with the tape archiving system MAREN is recommended.

MAREN is essential when the virtual archive system ETERNUS CS is used and is also required when multiple storage locations are to be employed, see [section “Storage location management” on page 71](#).

More detailed information on MAREN is provided in the “MAREN” manual [8].

Details on the interworking of ROBAR and MAREN are provided in [section “Interworking of ROBAR and MAREN” on page 70](#).

3 Working with ROBAR

The job submitters for ROBAR in the BS2000 systems are:

- tape-processing programs in BS2000
- the user program ROBAR-CL-SDF

When an MTC management job is issued in the BS2000 system, e.g. mounting a cartridge, it is filtered out by ROBAR-CL-DCAM and passed in the form of a message to ROBAR-SV on the ROBAR server.

ROBAR-SV receives the job that is transferred in the form of a message, evaluates it, and forwards it to the archive system. The so-called ROBAR rule files (RRFs), the files for execution control, are available in ROBAR-SV for this purpose (see [chapter “ROBAR rule files” on page 247](#)). These are device type specific files that contain definitions as to the actions that the archive system should perform in certain situations (when specific messages occur).

The ROBAR-SV software delivery includes a set of standard files. If the standard files do not fulfill all the requirements of your data center’s system environment, you can modify them on your own responsibility, see the [section “Modifications in the ROBAR rule files” on page 311](#).



You may not issue manually any BS2000 commands for MTC devices administered by the archive system while ROBAR is in use (e.g. `CHECK-TAPE ACTION=*REPORT` or `DETACH-DEVICE FORCE=*YES`).

Commands for an archive system can also be entered via the `MANUAL` menu of ROBAR-SV’s `robar` menu program.

3.1 Operating ROBAR

ROBAR can work together with an archive system only if you have started all the components of the ROBAR system after installing and configuring ROBAR-CL and ROBAR-SV.

3.1.1 Requirements for ROBAR operation

Before ROBAR operation is started, ROBAR-CL and ROBAR-SV must be fully installed and configured, see [chapter “Installation and configuration” on page 185](#). The ROBAR-CL and ROBAR-SV versions must be identical or at least compatible.

The following requirements must also be met:

- In the BS2000 systems and on the ROBAR server the ROBAR rule files must be adjusted to the system environment of the data center (see the [chapter “ROBAR rule files” on page 247](#))
- The ROBAR-CL-DCAM application must be started on the BS2000 systems (see the next section)
- The required ROBAR-SV instances must have been configured and started on the ROBAR server (see the [section “Operating ROBAR-SV” on page 39](#))
- The BS2000 and ROBAR servers and the ROBAR users must be known in the network
- At least one MTC device must be ATTACHED

3.1.2 Operating ROBAR-CL

ROBAR-CL on a BS2000 system consists of the DCAM application ROBAR-CL-DCAM and the user program ROBAR-CL-SDF, which are operated separately.

Starting ROBAR-CL-DCAM

Configure ROBAR-CL before starting ROBAR-CL-DCAM for the first time, see [section “Configuring ROBAR-CL” on page 187](#). Also ensure by means of the `SHOW-MESSAGE-SUPPRESSION` command that output of the messages `NBR0740` and `EXC0031` is not suppressed (by means of the `SET-MESSAGE-SUPPRESSION` command).

ROBAR-CL-DCAM is started by means of the `SYSPRC.ROBAR-CL.<ver> start procedure` (see [page 188](#)) using `/ENTER-PROCEDURE` or `/CALL-PROCEDURE`.

Start ROBAR-CL-DCAM on every BS2000 system that wants to communicate with ROBAR-SV (and therefore with an archive system).

If a BS2000 system is to work with several ROBAR-SV instances (and therefore with several archive systems), ROBAR-CL-DCAM must be started the corresponding number of times.

You can monitor the status of the connection between ROBAR-CL-DCAM and ROBAR-SV by means of a job variable which you can define in the ROBAR-CL-DCAM start procedure (`JV-NAME` parameter). The job variable indicates whether the connection between the BS2000 system and ROBAR-SV is functioning or whether it has been interrupted. The precise content of the job variable is contained in the installation file `SYSPAR.ROBAR-CL.<ver>.TEXT.D` or `E`, see [page 186](#). This function is available if you are using the JV software product (see the “Job Variables” manual [7]).

If you are using MAREN, you must start the start procedure in an environment in which the MARENADM program can also run. This means in particular that

- Disclose the MAREN password in the start procedure (see [page 188](#)).
- The user ID under which the start procedure is started must be able to access the MAREN syntax files.
- The user ID under which the start procedure is started must have the system privilege `TAPE-ADMINISTRATION` if the software product SECOS is in use.

Terminating ROBAR-CL-DCAM

You should terminate the ROBAR-CL-DCAM application that was started via the ENTER job by entering the /BCAPPL command (see the “BCAM” manual [1]):

```
/BCAPPL APPLICATION=<application_name>  
      [,MODE=DEACTIVATE,TYPE=NORMAL,W=YES]
```



This command must be called with its default values.

The <application_name> was defined as parameter PARTNER in the start procedure, see [page 188](#).

Starting ROBAR-CL-SDF

The ROBAR-CL-SDF user program is called via /START-ROBAR or /ROBAR.



ROBAR-CL-SDF supports the SPIN-OFF mechanism, see [page 80](#).

Some statements of ROBAR-CL-SDF can only be used for particular archive systems, see [section “ROBAR-CL-SDF statements” on page 80](#).

Terminating ROBAR-CL-SDF

The ROBAR-CL-SDF user program is terminated with the statement END.

3.1.3 Operating ROBAR-SV

3.1.3.1 Roles, users and user groups of ROBAR-SV

Administration and operation of ROBAR-SV involve various tasks which are contained in two task areas. These task areas correspond to two roles:

- ROBAR-SV administrator (ROBAR administrator for short)
This task area comprises the administration of ROBAR-SV and of the archive systems.
- ROBAR-SV operator (ROBAR operator for short)
This task area comprises the operation and monitoring of ROBAR-SV and of the archive systems.

A user who takes over a task area (in other words a role) is authorized to execute all functions which are needed to implement these tasks.

The set of functions for the ROBAR administrator includes the set of functions for the ROBAR operator.

While ROBAR-SV is being installed, two user groups and one user are defined for the two roles in the ROBAR server's Linux system:

- User group `robaradm` for the role of the ROBAR administrator



The ROBAR administrator must also be assigned to the `robarsv` user group.

- User group `robarsv` for the role of the ROBAR operator
- User `robar` as a member of the user group `robarsv`

The Linux system administrator on the ROBAR server can assign further suitable local users or LDAP users to these user groups.

ROBAR administrator

A user takes on the ROBAR administrator role when he/she logs on as a user who is assigned to the user group `robaradm` and to the user group `robarsv`.

The ROBAR administrator has the following tasks and authorizations:

- Managing the ROBAR-SV instances (see [page 41](#))
This includes in particular starting and stopping the ROBAR-SV instances and editing the global and interface-specific configuration files of ROBAR-SV.
- Manual entry of archive system commands (see [page 128](#))
- Managing the ROBAR rule files (see [page 311](#))
- Managing the global and the partner configuration (CMX) of the ROBAR server (see [page 140](#) and [144](#))
- Displaying information on the users of ROBAR-SV (see [page 139](#))

To perform these tasks, corresponding functions are available to the ROBAR administrator in the ROBAR-SV Manager and in the `robar` menu program.

ROBAR operator

A user takes on the ROBAR operator role when he/she logs in as a user who is assigned only to the user group `robarsv`.

The ROBAR operator has the following tasks and authorizations:

- Managing the ROBAR-SV instances (see [page 41](#))
This includes in particular starting, monitoring and stopping the ROBAR-SV instances.
- Working with the programs and files of ROBAR-SV
This includes in particular executing the commands, programs and scripts of ROBAR-SV



The user group `robarsv` has read-only authorization for the ROBAR-SV configuration files in the `/etc/robar/<interface>.conf.d` directory.

- Observing the interface-specific configuration files for the ROBAR-SV instances (processing is the responsibility of the ROBAR administrator).
- Diagnosing the ROBAR-SV instances (see [page 136](#))

To perform these tasks, corresponding functions are available to the ROBAR operator in the ROBAR-SV Manager and in the `robar` menu program.

3.1.3.2 ROBAR-SV instance

Each archive system is operated via a so-called ROBAR-SV instance.

Archive systems with SCSI interface are divided into partitions. Each partition requires its own ROBAR-SV instance.

If you intend to run several ETERNUS CS systems at the same time, a separate ROBAR-SV instance is needed for each archive system.

A ROBAR-SV instance consists of:

- its interface-specific configuration file (see [page 212](#))



The name of the ROBAR-SV instance's interface-specific configuration file is identical to the name of the ROBAR-SV instance.

- its runtime files (see [page 205](#))
- its ROBAR processes for communication with the archive system and the BS2000 systems

An installation of ROBAR-SV on the ROBAR server enables multiple archives (storage locations) or partitions to be operated via different ROBAR-SV instances, see [page 59](#).

The ROBAR administrator configures a ROBAR-SV instance by creating an interface-specific configuration file with the name of the ROBAR-SV instance.

The ROBAR operator manages the configured ROBAR-SV instances in the ROBAR-SV Manager (`ROBAR-SV Instances` menu) and in the `robar` menu program (`INSTANCES` menu). He/She can select, start and stop the ROBAR-SV instances and display information about them. The ROBAR-SV instance selected remains preset for further actions.

ROBAR-SV instances can also be predefined in the global configuration file `ROBAR-SV`. They are then started automatically, see [page 211](#).

3.1.3.3 Starting a ROBAR-SV instance

The ROBAR administrator or operator starts a ROBAR-SV instance in the ROBAR-SV Manager, in the `robar` menu program or using the `robar_start` program.

Preparations for the initial start of a ROBAR-SV instance

Configure a ROBAR-SV instance as a ROBAR administrator and create an interface-specific configuration file with the name of the ROBAR-SV instance (see [page 212](#)).

For this purpose the ROBAR-SV Manager offers a user-friendly wizard with which you can create a new ROBAR-SV instance either completely from scratch or by modifying an existing configuration file. You are recommended to proceed as follows:

- ▶ Start the ROBAR-SV Manager.
- ▶ In the `ROBAR-SV Instances` menu select the `Upload configuration file` button when you wish to upload a configuration file for the new instance from your PC to the ROBAR system.
- ▶ In the `ROBAR-SV Instances` menu select the `Create new instance` button. The wizard for creating a new instance is started.
- ▶ In the first step choose whether you want to create a ROBAR-SV instance either completely from scratch or by modifying an existing (or uploaded) configuration file.
- ▶ In the following steps enter the information required for the new instance. Using your information the wizard will create the interface-specific configuration file with the name of the ROBAR-SV instance.

Each additional ROBAR-SV instance requires its own interface-specific configuration file.

For the ABBA interface optionally create the ROBAR standard freepool in the `robar` menu program, `FREEPool` menu (see [page 159](#)).

The ROBAR standard freepool is required only when MAREN is **not** used in order to enable responses to unspecific cartridge requests.

Starting a ROBAR-SV instance with the ROBAR-SV Manager

- ▶ Start the ROBAR-SV Manager.
- ▶ In the `ROBAR-SV Instances` menu select the required instance.
- ▶ In the `Operation` tab click the action icon to start the instance.

Starting a ROBAR-SV instance using the `robar` menu program

- ▶ Start the `robar` menu program.
- ▶ Select the `INSTANCES` menu.
- ▶ Select the corresponding instance using the "up arrow" or "down arrow" key (inverse presentation) and select the `START` function. ROBAR-SV will start multiple ROBAR processes for communicating with the archive system and the BS2000 systems.
- ▶ Optional but recommended:
In the `INSTANCES` menu, `SELECT` function, select the highlighted ROBAR-SV instance if you also wish to address this ROBAR-SV instance from other masks of the menu program. The selection of the ROBAR-SV instance is also retained when the menu program is terminated.

Starting a ROBAR-SV instance using the `robar_start` program

The ROBAR administrator or operator can also start a ROBAR-SV instance using the `robar_start` program.

Call:

```
robar_start [--type=scsi/-s] [--type=abba/-a] <instance> [nocmx] [deltraces]
```

Operands:

<code>--type=scsi/-s</code>	Selects the SCSI interface
<code>--type=abba/-a</code>	Selects the ABBA interface (one of the interfaces must be specified)
<code><instance></code>	Name of the ROBAR-SV instance which is to be started
<code>nocmx</code>	This specification prevents the CMX components from starting (optional)
<code>deltraces</code>	This specification deletes the trace files (optional) The following trace files are deleted: <ul style="list-style-type: none"> – CMX trace files (<code>inotrc.*</code>) – Trace files of the ROBAR-SV instance – Backed-up trace files (see <code>RECOVER_DISK_FULL</code> script, page 54)

Example

```
robar_start -s myrobar deltraces
```

Job file of a ROBAR-SV instance

All jobs of a BS2000 system for MTC management which ROBAR-CL passes to ROBAR-SV are collected in the job file of the ROBAR-SV instance which is responsible for the archive system.

Check the size of the job files regularly. These files, whose size increases gradually, do not cause disk memory bottlenecks in sequences of average duration. However, if the size of the job file becomes critical in relation to the available disk memory space, ROBAR-SV instances must be stopped and restarted in order to open a new, and therefore empty, job file. The file cannot be deleted as long as the ROBAR-SV instance is active.

The `robar.mess` job file of an active ROBAR-SV instance is contained in the `/var/lib/<interface>/<instance>/cmx/` directory.

Status of the MTC devices when a ROBAR-SV instance starts

If a ROBAR-SV instance is started, it calls an entry `MFSAT` (`START-ATTACH`) predefined in the ROBAR rule files for all devices connected during the start.

The status of the MTC devices is checked by ROBAR-SV during the start. The entries `MFSMT`, `MFSKE` and `MFSOC` are called depending on the status of the MTC devices:

- `MFSMT` There is no data volume mounted on the MTC device (`MFSMT` stands for device `EMPTY`).
- `MFSKE` A data volume not used by BS2000 is mounted on the MTC device. This data volume should be removed using the `KEEP` command (`MFSKE` stands for `KEEP`).
- `MFSOC` The MTC device is reserved and is currently being used (`MFSOC` stands for `OCCUPIED`).

3.1.3.4 Stopping a ROBAR-SV instance

The ROBAR administrator or operator stops a ROBAR-SV instance in the ROBAR-SV Manager, in the `robar` menu program or with the `robar_stop` program. To stop a ROBAR-SV instance properly, the ROBAR instances which are running must first be terminated by ROBAR-SV.



Before you stop a ROBAR-SV instance, check whether all the actions have been terminated properly. This is particularly important for archive system commands such as `IVK` or `IN`. If the ROBAR processes are terminated prematurely, data inconsistencies can occur or messages can remain unanswered.

When the archive system switches to the `OFF` status, a message is sent to the BS2000 system. Depending on the `ROBOT_OFF_MSG` configuration parameter, this will be a `PAUSE` or `TYPE` message.

Stopping a ROBAR-SV instance with the ROBAR-SV Manager

- ▶ Start the ROBAR-SV Manager.
- ▶ In the `ROBAR-SV Instances` menu select the required instance.
- ▶ In the `Operation` tab click the action icon to stop the instance

Stopping a ROBAR-SV instance using the `robar` menu program

- ▶ Start the `robar` menu program.
- ▶ Select the `INSTANCES` menu.
- ▶ Select the corresponding instance using the "up arrow" or "down arrow" key (inverse presentation) and select the `STOP` function. ROBAR-SV will stop the ROBAR processes for communicating with the archive system and the BS2000 systems. The interface-specific configuration file of the ROBAR-SV instance is retained. The ROBAR-SV instance is consequently still configured and can be restarted.

Stopping a ROBAR-SV instance using the `robar_stop` program

The ROBAR administrator or operator can also stop a ROBAR-SV instance using the `robar_stop` program.

Call:

```
robar_stop [--type=scsi/-s] [--type=abba/-a] <instance>
```

Operands:

<code>--type=scsi/-s</code>	Selects the SCSI interface
<code>--type=abba/-a</code>	Selects the ABBA interface (one of the interfaces must be specified)
<code><instance></code>	Name of the ROBAR-SV instance which is to be stopped

Example

```
robar_stop -s myrobar
```

3.1.4 Automating the behavior of ROBAR-SV

The following measures automate the behavior of ROBAR-SV.

Configuration parameters

The `repetition_count` configuration parameter in the interface-specific ROBAR-SV configuration file (see [page 212](#)) determines how often ROBAR-SV attempts to set up the connection to the archive system during the start of a ROBAR-SV instance (default value: 1).

ROBAR-SV waits 15 seconds between each connection attempt. Setting this configuration parameter to a value > 1 makes particular sense when the archive system is controlled by multiple ROBAR-SV instances on an alternating basis.

Automatic restart of ROBAR-SV instances

When automatic restart is enabled for a ROBAR-SV instance, ROBAR causes a ROBAR-SV instance to be restarted automatically following an orderly program termination initiated by the user or by program events.

The configuration parameter `INIT_RESTART_OPTION` in the interface-specific configuration file of ROBAR-SV (see [page 212](#)) determines whether the automatic restart is enabled (YES) or not (NO) for a ROBAR-SV instance when it is started for the first time (default value: NO). The script `SET_RESTART_OPTION` or the ROBAR-SV Manager is then only required in the case of changes in the restart behavior of the ROBAR-SV instance.

For a ROBAR-SV instance in the `DEFINED` status, the automatic restart can be enabled or disabled before startup or during ongoing operation with the `SET_RESTART_OPTION_SCSI` or `SET_RESTART_OPTION_ABBA` command.

Syntax:

- `SET_RESTART_OPTION_SCSI <instance> YES/NO` for the SCSI interface
- `SET_RESTART_OPTION_ABBA <instance> YES/NO` for the ABBA interface

If necessary, ascertain the current setting using one of the following commands (only for ROBAR-SV instances, which are not in the `DEFINED` status):

- `cat /var/lib/robar_scsi/<instance>/.ROBAR_RESTART` (SCSI interface)
- `cat /var/lib/robar_abba/<instance>/.ROBAR_RESTART` (ABBA interface)



Note the information on resource bottlenecks given on [page 55](#) if this function is activated.

The automatic restart can also be enabled and disabled using the ROBAR-SV Manager (see [page 127](#)).

Changes in the setting for the automatic restart of a ROBAR-SV instance are effective only until the instance is reset or until ROBAR-SV is re-installed. The setting from the interface-specific configuration file of ROBAR-SV then applies.

3.1.5 Controlling the execution of ROBAR-SV

You can control the execution of ROBAR-SV using the configuration parameters of ROBAR-SV, and the ROBAR rule files (RRF).

In addition, you can specify settings for ROBAR-SV multiprocessing.

3.1.5.1 Configuration parameters and configuration files of ROBAR-SV

The configuration files of ROBAR-SV contain the global and interface-specific configuration parameters for executing ROBAR-SV. After ROBAR-SV has been installed, tailor these files to the current conditions in the data center, see [section “Configuring ROBAR-SV” on page 209](#).

The ROBAR-SV Manager offers a user-friendly ROBAR editor for editing the global configuration file (see [page 141](#)) and the interface-specific configuration file of a ROBAR-SV instance (see [page 126](#)).

3.1.5.2 Files for runtime control: ROBAR rule files (RRFs)

You can define your own console messages and how they are processed in the ROBAR rule files. Modify these files if the files supplied by default do not match all the requirements of your data center.

For a detailed description see the [section “Modifications in the ROBAR rule files” on page 311](#).

With the ROBAR-SV Manager you can edit, check and activate the modified ROBAR rule files of an instance (see [page 128](#)).

3.1.5.3 Multiprocessing

ROBAR-SV processes requests asynchronously and in parallel (multiprocessing). A ROBAR-SV instance can simultaneously process up to 10 requests per robot. The parallel processing of requests improves the response time if the current processing operation cannot be continued until a specific event occurs.

The following cases are an example of this:

- A cartridge is unloaded (message `NKVT097`) but still has to be rewound before it can be removed from the MTC device.
- A cartridge is unloaded because of an error but still must be rewound. However, the rewind operation takes longer than usual due to the error.
- The device must be cleaned before use.

The parallel processing of requests also permits the definition of longer waiting times without interruption to the robot processing operation.

You can determine the optimum settings (see [page 240](#)) by observing the behavior of the robot.

3.1.6 Obtaining information about ROBAR-SV

The information services provided by ROBAR-SV allow you to follow current actions of a ROBAR-SV instance on the screen, to have these actions logged in “trace files”, or to obtain information on the error logging or on certain settings.

First select the ROBAR-SV instance about which you wish to obtain information in the ROBAR-SV Manager (ROBAR-SV Instances menu), in the `robar` menu program (INSTANCES menu).

3.1.6.1 Displaying the status of the ROBAR-SV instance

In the ROBAR-SV Manager (ROBAR-SV Instances menu) the `BS2000 hosts & Library` tab displays the status of the BS2000 systems and information on the archive system of the selected ROBAR-SV instances. Such an overview is not provided in the `robar` menu program.

3.1.6.2 Displaying actions of the ROBAR-SV instance

The `Messages & Devices` tab in the ROBAR-SV Manager (ROBAR-SV Instances menu) and the `DISPLAY` menu of the `robar` menu program inform you of the current actions and the currently occupied devices of a ROBAR-SV instance.

The following information is output:

- All messages between the ROBAR-SV instance and the archive system.
- All messages between the ROBAR-SV instance and the BS2000 systems.
- All BS2000 systems connected to the ROBAR-SV instance.
- All devices belonging to the configuration.
Each device can be identified by its device mnemonic, by the associated BS2000 system, the VSN of the volume mounted on the device, or the TSN of the task working with this device.
- Messages relating to disruptions to connections between ROBAR-CL and the ROBAR-SV instance.

3.1.6.3 Trace files of the ROBAR-SV instances

Trace files are files in which all actions of a ROBAR-SV instance are logged. The current trace file of a ROBAR-SV instance is called `robar.trace` in the directory `/var/lib/<interface>/<instance>/trace/`.

ROBAR-SV also creates in this directory other internal trace files which are required for diagnostic purposes. These are `nbs2.trace`, `vbs2.trace`, `driver_scsi.trace`, `netgate_in.trace`, `netgate_out.trace`, `inotrc.<bs2000_partnername>` and `inotrc.monstg`. These internally used files contain above all information relevant to the connections.

You will find examples of the files `robar.trace`, `nbs2.trace` and `vbs2.trace` and their structure in [section “ROBAR-SV trace files” on page 332](#).

When a trace file reaches the size defined in the interface-specific configuration file (configuration parameter `trace_limit`), it is copied to a file with the name `<trace_datei>.<timestamp>`. `<timestamp>` is the time at which the old trace file is closed and the new one opened.

The trace files of a ROBAR-SV instance are administered in the ROBAR-SV Manager (ROBAR-SV Instances menu) using the Logging Files tab and in the `robar` menu program via the LIST menu.

Switching trace logging on/off

You can activate or deactivate the logging of trace information in ongoing operation by means of the commands `SET_DIAG_TRACE_SCSI` (SCSI interface) and `SET_DIAG_TRACE_ABBA` (ABBA interface) without having to terminate the ROBAR-SV instance.

The commands have the following format:

```
SET_DIAG_TRACE_SCSI <instance> [ON/OFF [*ALL/<components>]]
SET_DIAG_TRACE_ABBA <instance> [ON/OFF [*ALL/<components>]]
```

The variable operands have the following meaning:

`<instance>` is the name of the ROBAR-SV instance.
`<components>` is a list of either process IDs (PID) or component names separated by comma.

Possible component names:

- `robar_abba` (all `robar_abba` processes that are running)
- `robar_drive` (ABBA interface only)
- `robar_netgate` (`robar_netgate` parent and child processes, ABBA interface only)
- `robar_mon`

- robar_vbs2
- robar_nbs2
- robar_serv (all “Ext processors” with a connection to a client server)
- robar_trace
- robar_scsi (SCSI interface only)

You can determine the process IDs (PIDs) of the processes running for a specified ROBAR-SV instance with the following command: `ps -ef | grep <instance>`
<instance> is the name of the ROBAR-SV instance.

The maximum size of a trace file is defined in the interface-specific configuration file of ROBAR-SV: `trace_limit=<1000 .. 2147483647>` (bytes)

The value to be specified (1000 .. 2147483647) defines the maximum file size before a new file is opened.



Sufficient storage space has to be available for the trace files, see [section “Automatic disk storage monitoring” on page 54](#).

Displaying, downloading and printing out trace files

You use the `Logging Files` tab in the ROBAR-SV Manager (ROBAR-SV Instances menu, see [page 134](#)) and the `EDIT` parameter of the `DISPLAY` menu in the `robar` menu program to display the trace files of a ROBAR-SV instance.

You use the `Logging Files` tab in the ROBAR-SV Manager (ROBAR-SV Instances menu) to download trace files.

The `PRINT` parameter of the `DISPLAY` menu allows you to print the trace file for a given period.

Evaluating trace files - generating statistics

You can evaluate the information gathered in the trace files for outputting statistics.

You can output the following statistics for a given period:

- Summary statistics
- Host statistics
- Statistics on manual inputs
- Cleaning statistics
- IMPORT/EXPORT statistics
- Inventory statistics
- Error statistics

The `Diagnostics` tab in the ROBAR-SV Manager (ROBAR-SV Instances menu, see [page 136](#)) and the `EVAL` parameter in the `LIST` menu in the `robar` menu program are available to you to output statistics. You can display the result using the `SHOW` parameter and print it using the `PRINT` parameter.

The statistics and their report lists are described on [page 341](#).

Deleting trace files

You can delete trace files in the following ways:

- Automatic, periodical deletion of the trace files according to age using the `max_trace_file_age` parameter in the global configuration file of ROBAR-SV, see [page 211](#)
- Automatic, unconditional deletion of the trace files when a ROBAR-SV instance is started, see [page 42](#) and [page 181](#).
- For information on deleting individual trace files using the ROBAR-SV Manager, see [page 135](#).
- Deletion of trace files individually using the `DELETE` parameter in the `LIST` menu (see [page 165](#)).



For storage space saving reasons you are recommended to delete old trace files regularly.

3.1.6.4 Information on the error logging file

All the information about events which occur during ROBAR-SV operation (these also include system and application errors) is collected automatically in the central error logging file `/var/log/robar.log`.

Error logging is initialized when ROBAR-SV is installed.

The ROBAR operator has unrestricted access to the central error logging file.



The error logging information of ROBAR-SV is also written to the trace file of a ROBAR-SV instance.

3.1.6.5 Displaying certain settings

The following settings can be displayed:

- Console message (ROBAR rule files area of the ROBAR-SV Manager (see [page 128](#)) and the `SHOW` parameter in the `DEFINES` menu of the `robar` menu program)
The console message concerned is displayed together with the actions defined there.
- VSNs of the ROBAR standard freepool (`SHOW` parameter in the `FREEPool` menu of the `robar` menu program, ABBA interface only)
All VSNs which are contained in the ROBAR standard freepool are displayed.

3.1.7 Automatic disk storage monitoring

3.1.7.1 RECOVER_DISK_FULL script

Both ROBAR-CL and ROBAR-SV require free disk storage space to run correctly. The `file system full` state, particularly, may cause serious problems in ROBAR-SV. ROBAR-SV is equipped with automatic disk storage space monitoring to avoid the `file system full` state.

When the available space in the file system where a ROBAR-SV instance runs reaches the limit, an error logging record is generated and the `RECOVER_DISK_FULL` script is executed.

`RECOVER_DISK_FULL` causes the following actions:

- The ROBAR-SV instance is terminated.
- The tar files `ROBAR-SV.<interface>_<instance>.<file>.<timestamp>.tar` are created in the `/var/opt/fujitsu/robar` directory, Here `<file>` has one of the values `cmx`, `trace.inotrc`, `trace.nbs2`, `trace.vbs2`, `trace.netgate_in`, `trace.netgate_out`, `trace.robar` or `trace.driver_scsi` (SCSI interface only).
- The contents of the directories `cmx` and `trace` of the ROBAR-SV instance is copied into the respective tar file. Next, the tar files are compressed. The contents of the directories `cmx` and `trace` is deleted.
- If a specific directory was defined in the `ROBAR_BACKUP_DIR` configuration parameter (see [page 211](#)), the compressed tar files are moved into it.
- The ROBAR-SV instance is then started again.

Disk space monitoring is controlled using the configuration parameter `min_disk_space=<limit_value>` in the global ROBAR-SV configuration file (see [page 210](#)).

The value `<limit_value>` means:

- absolute free disk capacity in bytes (permissible value range: 1000000 ... 2147483647)
- relative free disk capacity in percent (1% ... 99%)

The value `0` or `0%` means that the free disk space is not monitored. If `min_disk_space` is not specified, the absolute value `1000000` is used as a default. If `min_disk_space` is not specified, the absolute value `1000000` is used as a default.

As a ROBAR operator you can adjust the script `RECOVER_DISK_FULL` to the requirements of your data center at your own responsibility.



If no problems are to occur with the script `RECOVER_DISK_FULL`, the following message must definitely be observed.

By default, the compressed `tar` files are stored in the system directory `/var/opt/fujitsu/robar`. The system support must make sure that there is always sufficient storage capacity available in the directory for all operational situations that might occur, in particular for the use of ROBAR. If this is not the case, the system may become blocked because logging, for instance, is not possible.

You can select a different directory using the configuration parameter `ROBAR_BACKUP_DIR` (see [page 210](#)) in the global ROBAR-SV configuration file. The selected directory must be situated in a different file system than the ROBAR-SV installation. Here, too, the system support must make sure that sufficient storage capacity is available at all times.

You can use the `cron` daemon to automate deletion and to make sure that only older data is deleted.

Trace files saved by the `RECOVER_DISK_FULL` script are unconditionally deleted when a ROBAR-SV instance is started by specifying the `Delete trace files` parameter. They are deleted periodically and when a ROBAR-SV instance is started if they are older than the number of days defined in the global configuration file of ROBAR-SV using the `max_trace_file_age` parameter (see [page 211](#)).

The `/var/lib/<interface>/<instance>/RECOVER_DISK_FULL.TRACE` file informs you of how far the `RECOVER_DISK_FULL` script has progressed.



All `RECOVER_DISK_FULL` jobs write their logs into this file. It should therefore be cleared on a regular basis in order to avoid space problems.

If the `RECOVER_DISK_FULL` job cannot be completed successfully due to insufficient resources, an entry with the time and reason of the abort is written into the `RECOVER_DISK_FULL.TRACE` file. Relevant entries are also made in the operating system's logging files. The ROBAR-SV tasks are terminated.



One reason for insufficient resources may be that too many files need to be saved. In this case you have to delete superfluous files manually.

If `RECOVER_DISK_FULL` jobs cannot be terminated successfully and the automatic restart of the ROBAR-SV instance (see [page 46](#)) is enabled, restarting a ROBAR-SV instance may continually fail due to a lack of resources.

3.1.7.2 Disk monitoring on SE servers

A disk monitor is used constantly on SE servers. This periodically monitors the space occupied by the ROBAR instances and optimizes it if necessary.

For this purpose the `/opt/fujitsu/robar/common/robaradm` script is called (cron job) every hour. The script limits the storage space used by all ROBAR instances to one GB. When this value is exceeded, old archived trace files are deleted and the `RECOVER_DISK_FULL` script is called to reduce the storage space.

The script logs its actions in the general ROBAR-SV error logging file (see [page 53](#)).

3.1.8 Managing MTC devices

The BS2000 device management system (NDM) selects the device on which an MTC is to be mounted. NDM selects a device which supports the volume type of the cartridge .

All devices which are to be controlled by a ROBAR-SV instance in an archive system are defined in the interface-specific configuration file of ROBAR-SV when ROBAR-SV is configured (see [page 212](#)).

The storage location management facility as described in [section “Storage location management” on page 71](#) guarantees smooth operation. This means in particular that the BS2000 device management system (NDM) must be made aware of which device belongs to which storage location and that tape management must be performed by MAREN. If all devices and data volumes have been correctly assigned to the storage locations, the cartridges are also mounted on the device selected by NDM, even if there are a number of archives containing devices of the same type.

3.1.8.1 Fixed device allocation

ROBAR supports fixed device allocation only. It will only initiate mounting of cartridges for those MTC devices that are suggested by the BS2000 device management system (NDM) (identifier F in column 78 of the archive system command M0 in the `roboter_cmds` file).

3.1.8.2 Unloading an MTC device

Tape applications should release MTC devices after they have been completed to prevent operation of the archive system from being impaired.

The following command helps the operator to ensure smooth operation of the archive system (see also “Commands” [3]):

```
/MODIFY-MOUNT-PARAMETER
  UNLOAD-RELEASED-TAPE=*REGARDLESS-OF-USER-REQUEST(TAPE-FAMILY=*MBK) ,
  NEXT-TAPE-MOUNT=*LEAST-RECENTLY-USED-DEVICE ,
  PREMOUNT-MSG=*IGNORE-USER-REQUEST
```

These settings cause cartridges to be unloaded immediately after they have been used, the devices to be reserved one after the other, and the display of the `PREMOUNT` message to be suppressed.

An unload operation is performed as follows:

By a console message (NKVT097 or NKVT011, if applicable) it is indicated that the BS2000 system initiated an unload request. In response, ROBAR sends a KEEP statement to the archive system, causing the robot to remove the cartridge from the specified device and place it to its original storing position.

In the default configuration of the ROBAR rule files, ROBAR initiates unloading of the cartridge only in exceptional cases (e.g. during a mount job on a device which is still loaded or after a serious device error). Since in ROBAR operation unloading is only possible via the BS2000 system, ROBAR-SV enters the /UNLOAD-TAPE command in the BS2000 system for this purpose. The KEEP statement which ROBAR-SV sends to the archive system only causes the cartridge which has just been unloaded to be returned to its storage location.

3.1.8.3 Handling MTC device errors

In the event of errors in the MTC device, the BS2000 device management facility initiates unloading and issues a message to use a different device (NKVT014). Such remount situations arise, for example, in the case of hardware malfunctions affecting the devices.

The objective of ROBAR is to maintain unmanned archive operation even in the event of problems.

Action sequences defined in the ROBAR rule files permit automatic handling of I/O errors. The system can thus deal with any errors that may arise, such as device malfunctions, without external assistance.

Further information is provided in [section “Defective MTC devices” on page 325](#).

3.1.9 Working with multiple archives

A data center can have multiple robot-controlled archives, for example the data backup archive and the fire copy archive.

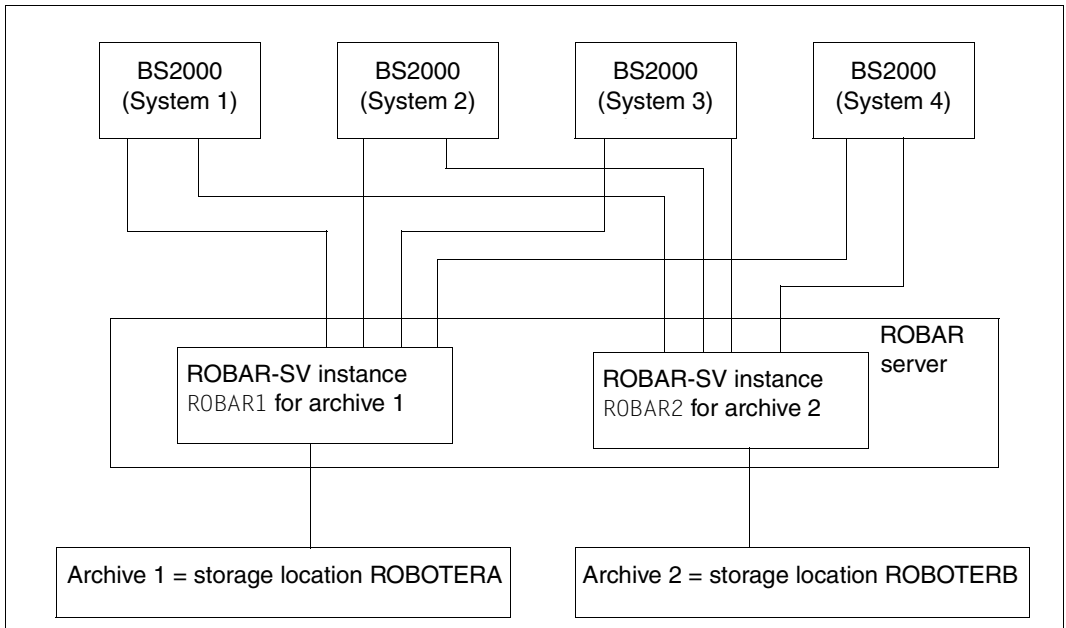

Figure 4: Example of a configuration for operating multiple archives

The subdivision of an archive system into multiple storage locations or partitions also results in multiple (logical) archive systems.

An installation of ROBAR-SV on a ROBAR server enables multiple archive systems to be operated when a separate ROBAR-SV instance is used for each archive. Each ROBAR-SV instance requires its own connection to the archive system.

The definition of a separate storage location for each archive guarantees that the cartridges are processed correctly (see [“Importing cartridges” on page 60](#)).

Creating the configuration files

Each ROBAR-SV instance, i.e. each archive, requires its own interface-specific ROBAR-SV configuration file, see [page 212](#).

The number of the archive (not to be confused with the archive number in cartridges) is used to define the default communication settings to BS2000 systems. If a value is defined explicitly for the communication parameters, any value in the range 1 through 4 can be used for the number of the archive, see “[archive_serial_number configuration parameter](#)” on [page 220](#). This allows a number of archives to be started. If no default values are used, identical numbers can be used a number of times for archives (see the section on local names in CMX and in the configuration, [page 238](#)).

Up to 110 BS2000 systems can be attached to each of the archives.

The start file `SYSPRC.ROBAR-CL.<ver>` for starting the DCAM application ROBAR-CL-DCAM must be copied, modified and called as many times as there are archives.

The `PARTNER` parameter in the `SYSPRC.ROBAR-CL.<ver>` start file must be unique for each archive.

If you are using the “JV” software product, the parameter `JV-NAME` must also be unique. The job variable need only be unique within a BS2000 system. One job variable must be defined for each archive.

See also the [section “Configuration variants” on page 243](#).

Importing cartridges

If cartridges are imported using the ROBAR-CL-SDF statement `IMPORT-ROBAR-VOLUME`, you must ensure that they are imported into the correct archive. For this reason, each archive should also be defined as a separate storage location.

The `LOCATION` configuration parameter is used to control into which archive the import is to take place.

3.1.10 Backing up and restoring ROBAR configuration files

The ROBAR administrator can back up and restore the ROBAR configuration files.

In this case the global and interface-specific configuration files of ROBAR are backed up in a `tar` archive.

ROBAR configuration files can be backed up and restored both via the ROBAR-SV Manager (see [section “Backing up and restoring ROBAR configuration files” on page 142](#)) and using scripts `BACKUP_ROBAR_CONF` and `RESTORE_ROBAR_CONF`. When the ROBAR-SV Manager is used, further functions are available for managing the backup archive.

The ROBAR configuration files are backed up as a `tar` archive in the `/var/opt/fujitsu/robar/config_backup` directory.

The file name is `<server name>_ROBAR_conf_<yyyy-mm-dd_hh:mm:ss>.backup.tar.gz`.

The ROBAR configuration files are backed up once only. Any backup archive which already exists is deleted by subsequent backups or when a backup archive is uploaded.

Restoring the ROBAR configuration files has no immediate repercussions on current ROBAR operation.

Scripts `BACKUP_ROBAR_CONF` and `RESTORE_ROBAR_CONF`

The ROBAR administrator can execute these scripts. They are contained in the `/usr/bin` directory.

`BACKUP_ROBAR_CONF` has no parameters.

`RESTORE_ROBAR_CONF` requires the name of the backup archive as a parameter.

Example

```
RESTORE_ROBAR_CONF /var/opt/fujitsu/robar/config_backup/  
ibarobt_ROBAR_conf_2014-09-10_14-23-26.backup.tar.gz
```

3.2 Working with ROBAR (SCSI interface)

ROBAR operates and controls the Scalar i500, i2000 and i6000 archive systems via the SCSI interface, see [page 23](#).

Archive systems with SCSI interface are divided into partitions. Each partition requires its own ROBAR-SV instance.

3.2.1 Importing and exporting cartridges

For functional and security reasons, an archive system constitutes a closed system. In certain cases, however, volumes must be added to or removed from the archive system. For this purpose the archive systems are equipped with input/output units. Changes to the data stored in the archive system can be initiated by any BS2000 system.



The functions for making changes to the data stored (Import, Export, Move Media) which are offered at the administration interface of the archive systems may not be used in ongoing ROBAR operation.

3.2.1.1 Importing cartridges

When you want to import cartridges into the archive system, i.e. into the partition which is controlled using the ROBAR-SV instance (see [page 29](#)), the operator must deposit these cartridges in the input/output unit.



In the **Scalar i500** archive system the partition into which the cartridges contained in the input/output unit are to be imported must be selected on the operator panel before they are imported.

In the **Scalar i2000** and **i6000** archive system the operator must deposit these cartridges in the area of the input/output unit which is assigned to the partition concerned.

Cartridges can only be imported if they have a valid (i.e. one which is certified by Quantum Corp.), certified and completely readable barcode label.

After a cartridge has been deposited in the input/output unit, you should always import it using the ROBAR-CL-SDF statement `IMPORT=ROBAR-VOLUME`. If MAREN is being used, the import job is passed to MAREN; the MAREN catalog is accessed accordingly. Direct import via MAREN is not possible.

When cartridges are imported, no check is made against the VSNs declared in the configuration parameter `ROBAR_ARCHIV` (see [page 218](#)). Consequently volumes can have reached the archive system which are not yet contained in the configuration parameter `ROBAR_ARCHIV` and are only to be released for use with this ROBAR-SV instance later by extending `ROBAR_ARCHIV`.

ROBAR initiates transport of the cartridge(s) from the input/output unit to a storage location which is marked as free in the archive record.

If MAREN is being used, it is notified after this transport has been successfully completed, i.e. in the MAREN catalog the tape is marked as imported and the storage position in the archive is specified in the `TEMPORARY-LOCATION` parameter.

At the end of the import process the following message is issued on all MAREN systems:
ROB0037 INSERT COMMAND TERMINATED

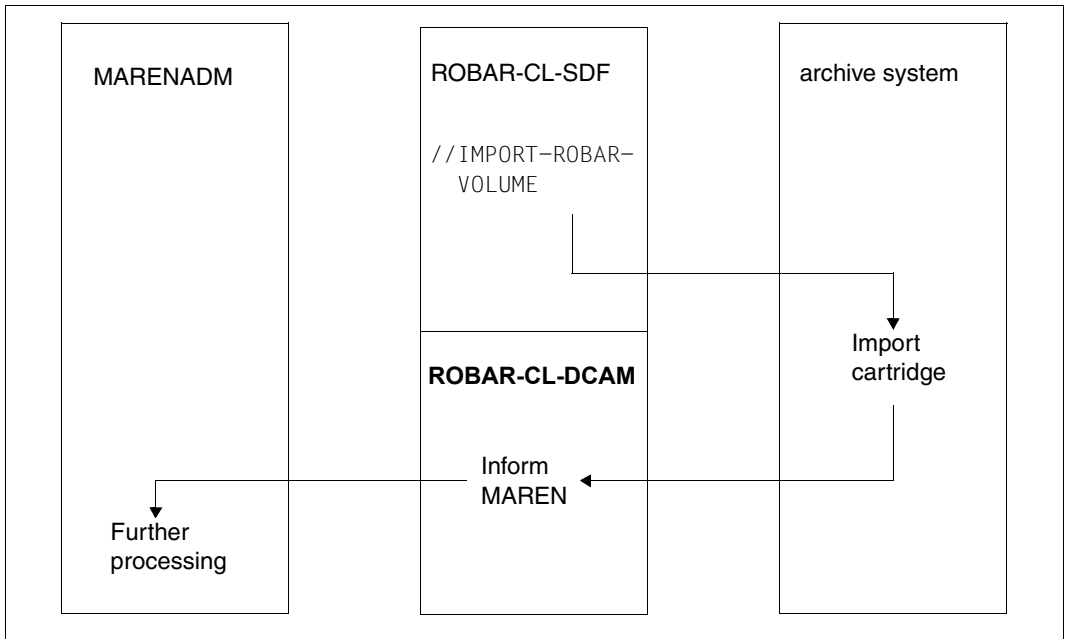

Figure 5: Sequence of an import process when using MAREN

Errors during import

- If a cartridge could not be identified, e.g. because the barcode label cannot be read successfully or is missing, the cartridge will remain in the input/output unit. The operator is informed by the message `ROB7010`.
- When cartridges are imported, ROBAR checks whether a cartridge with the same VSN is already contained in the partition. Any duplicated cartridge is ignored and will remain in the input/output unit. The operator is informed by the message `ROB4046`.
- If there is no free storage location in the archive system, the cartridge will remain in the input/output unit. The operator is informed by the message `ROB4045`.

3.2.1.2 Exporting cartridges

If MAREN is being used, the MAREN statement `EXPORT-VOLUME` should be employed when exporting cartridges, **not** the ROBAR-SDF statement `EXPORT-ROBAR-VOLUME`. The MAREN catalog then remains consistent with the archive record. This avoids inconsistencies that could otherwise occur while the export process is underway since, when ROBAR-CL-SDF is being used, MAREN is not informed until the export process is over.

If MAREN is not being used, you export the cartridges using the ROBAR-SDF statement `EXPORT-ROBAR-VOLUME`.

If cartridges are to be exported from the archive, the robot must fetch them from their storing position and deposit them in the input/output unit.



If cartridges of a partition are already contained in the input/output unit when the **Scalar i500** archive system is being used, only cartridges of the same partition can be exported.

In the case of the **Scalar i500** archive system the input/output unit must be opened, emptied and closed again after cartridges have been exported. Only after this has been done can actions be performed again with the input/output unit.

In the case of the **Scalar i2000** and **i6000** actions with the input/output unit are also possible when cartridges are still contained in the input/output unit.

After the door of the input/output unit has been closed, ROBAR automatically takes stock. ROBAR checks whether some storage locations have not been cleared by the operator. ROBAR then marks these storage locations as occupied in its archive record, and they are not available for the next export.

When a cartridge is exported to the input/output unit, ROBAR-SV sets the status of the original storage location to “free” in its archive record and deletes the VSN. This storage location is then no longer connected to a specific cartridge, and ROBAR-SV can assign it for other cartridges. After a cartridge has been removed from the input/output unit, its VSN is not known in either the archive system or ROBAR-SV. Only MAREN might possibly still know the VSN and can supply information about the MTC status.

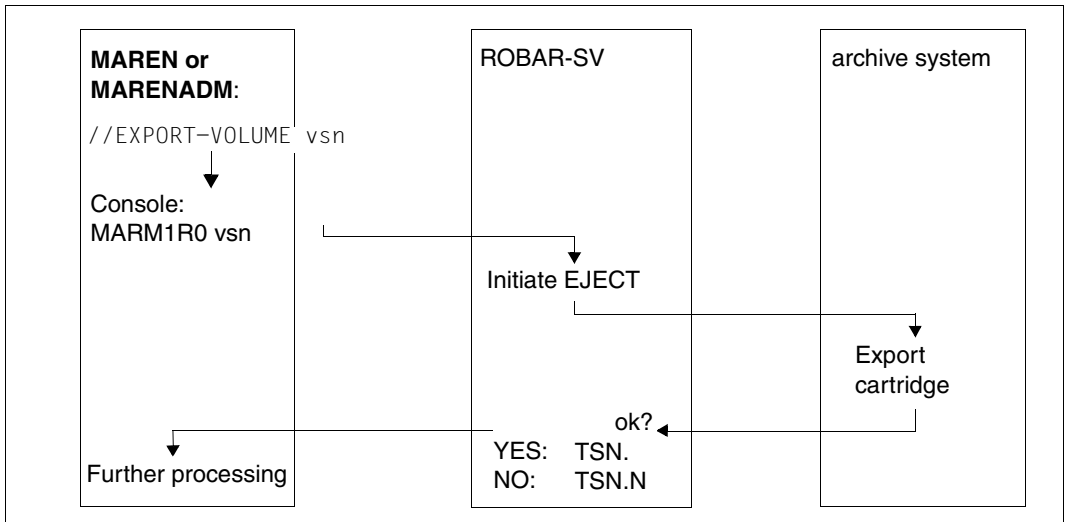

Figure 6: Overview of an export process using MAREN

Errors during export

If a transport command cannot be executed because the input/output unit's door is open or the input/output unit is full (Scalar i500 and i2000), the following PAUSE message is output to the console of the relevant BS2000 system:

```
ROB0035 I/O UNIT FULL --> PLEASE REMOVE CARTRIDGES
```

In addition, the job not executed is entered in the

`/var/lib/robar_scsi/<instance>/cmx/robar.eject` file. The task that initiated the transfer is in the wait status as a result of the unanswered MAREN message and can only continue to execute when the output area has been emptied.

After the output area has been emptied and the input/output unit's door has been closed, ROBAR automatically takes stock.

The further procedure for the export process can be defined using the action key `MRV30`. The option has to be activated in the ROBAR rule file `message_resp` under the action key `MRV30`. The following situations may occur:

- :MRV30: WAIT 0

The export process is not continued automatically.

When the input/output unit is empty, the operator has to issue the following command: `/SEND-MESSAGE TO=OPERATOR, MESSAGE='<T I/O-BOX EMPTY'`
- :MRV30: EJECT-CONT

As soon as the door of the input/output unit has been closed, ROBAR continues with the export process.

Exporting using ROBAR-SV

In exceptional cases you can also export cartridges manually. The following archive system commands are available for this purpose:

EJ, EJT Exports a cartridge and deletes the archive record entry

EJP, EJTP Exports a range of cartridges

If required, enter the archive system command in the ROBAR-SV Manager (see [page 128](#)) or in the `MANUAL` menu.

3.2.2 Mounting and dismounting cartridges

ROBAR receives mount and dismount requests for cartridges via a tape-processing program. These requests specify the VSN.

Cartridges cannot be mounted directly from the input/output unit; they must be imported first.

3.2.2.1 Mounting cartridges

Mounting requests initiate the following actions:

- ROBAR converts the BS2000 console messages directly into mount statements for the archive system.
- The archive system passes the corresponding commands to the robot.
- The robot identifies the cartridge by means of its barcode label.
- If the cartridge is mounted and can be identified by the tape monitor of the BS2000 system (device manager), the tape monitor itself responds to the mount message. In certain situations, e.g. in the case of a `PREMOUNT` message, during cartridge initialization, during `FDDRL` runs and all other special cartridge uses, ROBAR must send the BS2000 system issuing the request an acknowledgment of the volume mount operation.

3.2.2.2 Dismounting cartridges

When ROBAR recognizes a dismount job initiated from the BS2000 device management, the robot is instructed to remove the cartridge from the device after it has been unloaded and to return it to its original storage location (see also [section “Unloading an MTC device” on page 57](#)).

The archive record is then updated by the ROBAR-SV instance.

3.2.3 Device cleaning and cleaning cartridges

After a certain number of mount operations, the MTC devices must be cleaned. For cleaning use the special “cleaning cartridges”.

The cleaning cartridges must be contained at storage locations in the partition of the archive system which is controlled by the ROBAR-SV instance; they must therefore have been imported. Cleaning cartridges must have a valid barcode label which begins with `CLN`. ROBAR recognizes a cleaning cartridge by means of this and uses it to clean MTC devices.

Cleaning takes place only when it is explicitly requested by the device controller concerned (“cleaning on request”), i.e. ROBAR only initiates the cleaning process if a BS2000 message `EXC0858` with error code `CLRQ` (Clean Request) was issued. Only MTC devices which incorporate this function are permitted in the archive system.



Multiprocessing allows several cleaning procedures to be performed at the same time. Sufficient cleaning cartridges must be available in the archive system to permit this.

If an error occurs during the cleaning operations, processing of the job is canceled and the system branches to the `RCLN` error exit (see [page 269](#)).

The storage locations for cleaning cartridges which are provided in **Scalar i500** are not used.

Cleaning cartridges may not be mounted manually.

The `MANUAL` menu consequently contains no command for mounting a cleaning cartridge. In the `roboter_cmds` file you may not modify the line with the code `RC004`.

Replacing cleaning cartridges

A cleaning cartridge must be replaced by a new one after a given number of cleaning operations. The end of a cleaning cartridge’s service life is determined by BS2000 and reported to ROBAR by means of the message `NJT0031`.

The configuration parameter `MAX_CLEAN` (see [page 229](#)) has no meaning.

The export of an expired cleaning cartridge is initiated by ROBAR.

The operator is notified by ROBAR so that he/she can import a new cleaning cartridge into the archive. The following message is output on the BS2000 console:

```
ROB4047 EXPIRED CLEANING CARTRIDGE EJECTED: INSERT NEW ONE
```

New cleaning cartridges are integrated into the archive system using the ROBAR-CL-SDF statement `IMPORT-ROBAR-VOLUME`, see [section “Importing cartridges” on page 62](#).

3.3 Working with ROBAR (ETERNUS CS, ABBA interface)

ROBAR operates and controls the virtual archive system ETERNUS CS via the ABBA interface, see [page 23](#).

If you intend to run several ETERNUS CS systems at the same time, a separate ROBAR-SV instance is needed for each archive system. The volumes of each archive system have to be allocated to a location of their own.

3.3.1 Mounting cartridges

Mounting requests of a tape-processing program initiate the following actions:

- ROBAR converts the BS2000 console messages directly into mount statements for ETERNUS CS.
- ETERNUS CS processes the mount statements.
- If the cartridge is mounted on a virtual MTC device and can be identified by the tape monitor of the BS2000 system (device management), the tape monitor itself responds to the mount message. In certain situations, e.g. in the case of a PREMOUNT message, during cartridge initialization, during FDDRL runs and all other special cartridge uses, ROBAR must send the BS2000 system issuing the request an acknowledgement of the volume mount operation.

Fast mount support

After it has been defined in the virtual archiving system, i.e. after it has been initialized, a virtual volume is automatically allocated to the “fast mount” category to which any unused virtual volume belongs. When a virtual volume is “mounted” **for the first time**, it is made available in the cache as a “fast mount” volume. In other words the volume is immediately available for writing. The time for mounting, etc. is irrelevant in the case of fast mount volumes.

Pre-restore function

ROBAR-SV supports the “pre-restore” function for cartridges to control ETERNUS CS. This permits early provision of the data residing on the cartridges in the ETERNUS CS system’s cache so that it can be used later.

When the BS2000 components DMS, ARCHIVE and FDDRL start to use a cartridge, they already know whether a continuation tape is to be processed later. They then issue the mount statement for the continuation tape by means of special console messages.

ROBAR takes into account the corresponding BS2000 messages `DMSODDE`, `ARC0850` and `FBD4015` and sends the pre-restore request to ETERNUS CS.

3.3.2 Dismounting cartridges

When ROBAR recognizes a dismount job initiated from the BS2000 device management, it converts the BS2000 console message directly into a dismount statement for ETERNUS CS. ETERNUS CS processes the dismount statement and updates the archive record.

Releasing a virtual volume

Released virtual volumes should always be initialized again before they are reused (volume attribute `PROTECTION(INITIALISATION=*YES)`).

3.4 Interworking of ROBAR and MAREN

In ROBAR operation you should also use MAREN, the tape archiving system in BS2000. The use of MAREN is a prerequisite for ETERNUS CS.

To manage the tapes, MAREN has internal interfaces to the BS2000 components Data Management System (DMS) and the device management system (NDM). It determines free tapes that are to be overwritten on the basis of reservation times and issues its own MOUNT statements. This prevents protected data from being inadvertently overwritten.

MAREN checks access to tapes. Each time a tape request is issued, MAREN checks whether the user issuing the request is in fact allowed to access the desired tape. More detailed information on MAREN is provided in the “MAREN” manual [8].

Selecting the central MAREN system

If a BS2000 system is selected as the central MAREN system in the interface-specific ROBAR-SV configuration file (see [page 212](#)), the export and import information is sent to this system alone and not to all connected systems. The central MAREN system must be available when exporting and importing the tapes. A maximum of 10 central MAREN systems can be specified.

To prevent unnecessarily long access times, only the central MAREN system on which the MAREN catalog was installed should be defined under ROBAR. Otherwise the other systems would receive redundant information and would laboriously update their MAREN catalogs.

Initializing cartridges

In an archive system controlled by ROBAR, tapes should always be initialized using MAREN(MARENADM). The mount request is issued through the MAREN statement INITIALIZE-VOLUMES and the message MARM1IB is issued.

You can also initialize a volume using the INIT utility program. In this case message NKVT013 is displayed.

3.4.1 Storage location management

This section provides an overview of how storage locations are managed when MAREN is used in conjunction with ROBAR.

Tapes and the tape devices on which they are mounted must be allocated to storage locations. Defined storage locations enable users to reserve tapes and tape devices from a specified group.

If all tapes and tape devices are correctly allocated to the storage location, a tape is also mounted on the device selected by NDM. This is also the case if a number of archives with devices of the same type exist.

If the SECOS software product is being used, the software products ROBAR and MAREN must be installed under user IDs which have the `TAPE-ADMINISTRATION` privilege. We recommend that you install ROBAR and MAREN under the same ID (`$SYSMAREN`).

For more detailed descriptions of, for example, the statements and commands of BS2000 products mentioned in this section, refer to the manuals “Introduction to System Administration” [2] and “MAREN” [8]

3.4.1.1 Storage location

A storage location can be:

- a central archive identified, for example, by the name `CENTRAL`
- one storage location for processing per BS2000 system, identified by the system name
- an archive, which has to be assigned operating mode `ROBAR-2` in MAREN when ETERNUS CS is used and operating mode `ROBAR-1` when a real archive system is used. A logical storage location is always assigned to the archive. A ROBAR-SV instance can manage exactly one MAREN storage location.
- other archives, identified by freely selectable names such as `SAFE`, `FIRECOPY` etc.

Each storage location is identified by its name `<a1phanum-name 1..8>`.

3.4.1.2 Preparations

You must make the preparations described on the following pages before tapes and tape devices can be addressed via their storage locations (see also [figure 7 on page 73](#)).

Setting up the storage location

Use the MARENADM statement `MODIFY-MAREN-PARAMETERS` to add a new entry to the storage location table maintained by MAREN.

The locations are stored there with name, symbolic name, session number (only in the case of storage locations for processing) and storage location ID.

The default value for the location is specified using the `DEFAULT-HOME-LOCATION` operand of the MARENADM statement `MODIFY-MAREN-PARAMETERS`.

The MARENADM statement `SHOW-MAREN-PARAMETERS` provides information on the storage location table.

Allocating tapes to the storage location

Use the MARENADM statement `MODIFY-VOLUME-ATTRIBUTES` to allocate the tapes to the storage locations by means of their archive numbers. Depending on their use, tapes can be placed in three types of storage location:

- `HOME-LOCATION = <storage-location_name>`
Storage location in which the tape is stored by default
- `FREE-LOCATION = <storage-location_name>`
Storage location to which the tape is to be relocated if it is to be transferred to the pool for free tapes after the expiration date has passed
- `TEMPORARY-LOCATION = <storage-location_name>`
Current storage location of the tape

The storage location name is kept by MAREN in the MAREN catalog. The MARENADM statement `SHOW-VOLUME-ATTRIBUTES` provides information on the locations allocated to the tapes.

Each storage location must have the appropriate operating mode assigned to it, i.e. operating mode `ROBAR-2` for ETERNUS CS and operating mode `ROBAR-1` for a real archive system.

Specifying the storage location for applications/users

The storage location can be specified for different applications or users via the MAREN exits 1 and 6 or via MARENLM. You can also define the storage location explicitly via HSMS/ARCHIVE, NDM and HSMS.

Allocating tape devices to storage location

The `ADD-DEVICE-DEPOT` operator command is used to allocate a tape device to a storage location. The NDM device management facility is informed simultaneously. The name of the storage location must match the name defined in MAREN. One storage location can hold up to 384 tape devices. The `REMOVE-DEVICE-DEPOT` operator command cancels this allocation once more. The `SHOW-DEVICE-DEPOT` operator command provides information on the allocation of cartridge devices to storage locations.

Defining a storage location in ROBAR

In ROBAR, the storage location name is specified in the interface-specific ROBAR-SV configuration file. The name must match that specified in MAREN and BS2000, see also [figure 7](#). An archive is the same as a storage location.

ROBAR supports one storage location per ROBAR-SV instance. If a number of storage locations are to be supported for the same archive system, one instance of ROBAR-SV is needed per storage location, see [page 59](#).

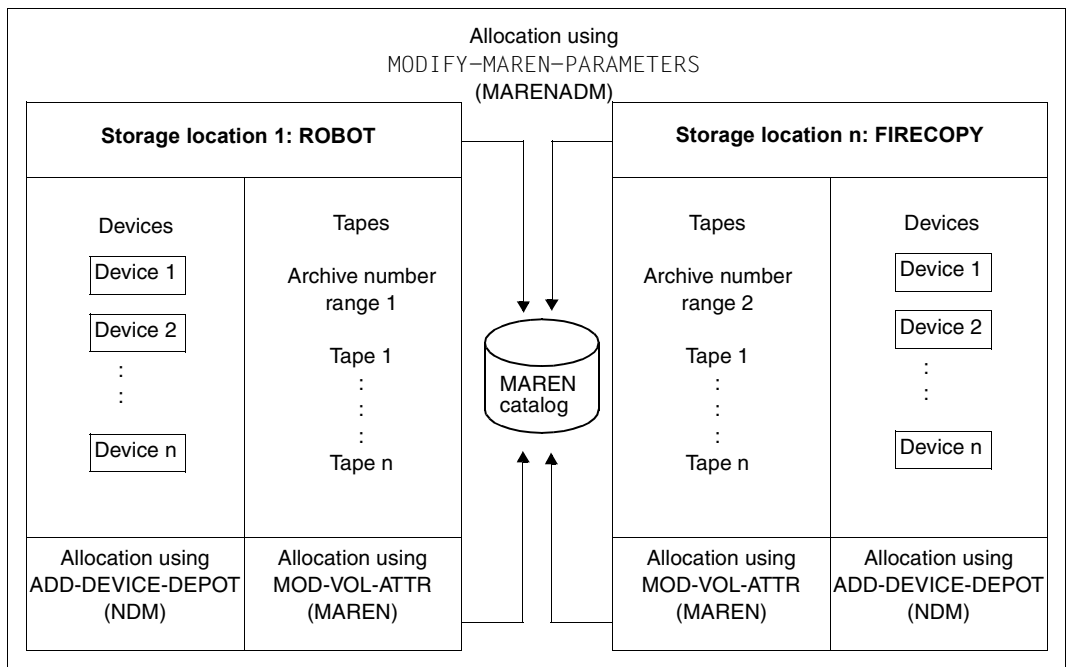

Figure 7: Preparations for cross-system storage location management

Making the preparations described above will ensure that the tape mount operations and the interaction of BS2000, MAREN and ROBAR run smoothly.

Example

A storage location called `ROBABBA1` is to be added. The tape devices `A1`, `A2`, `M1` and `M2` and the tapes from the range of archive numbers `TAPE01` to `TAPE10` are to be allocated to this location. For the following statements and commands, you must have the `TAPE-ADMINISTRATION` privilege.

```
/START-MARENADM _____ (1)
//MODIFY-MAREN-PARAMETERS LOCATION-NAME=ROBABBA1 _____ (2)
//SHOW-MAREN-PARAMETERS _____ (3)
```

```
HOST-NAME = ABGQS503  SNO          = 002      DOMAIN = *STD-DOM   ADA-ALLOW = N
EXP-PROC   = Y          INPUT-F-CH = N        FOREIGN-T-CH = Y   TSOS-PRIV = N
EXP-FOREIGN = N        INPUT-T-CH = Y        RETPD-CHECK  = Y   DEV-COMPL = Y
EXP-ADDR-ACK = N      AUDIT       = YES      TEST-MODE    = N   LOGGING    = N
EXP-RECEIPT = NO

BATCH-REQ-TIME=01800  DEF-FREE-DATE = 0007      ARCH-WORK-TIME = (00:00,24:00)
BATCH-EX-TIME =00100  DEF-HOME-LOC  = CENTRAL    PRIV-USER-ID   =
DIAL-REQ-TIME =00180  DEF-DEV-TYPE = TAPE-C4    EXITS          = NONE
DIAL-EX-TIME  =00050  DEF-USER-ACC = FOREIGN-READ-ONLY
CID-UID       = Y      DEF-ADM-SCOPE = *OWN      LAYOUT-FOR-SHOW= MAXIMUM
MOUNT-CH-INT  =                RESERVATION-SEQ=
                                           OPERATOR-ROLE  = SYSMAREN

MAREN-PASSWORD=NONE

RES-DEV-TYPES =(TAPE-C4 /TAPE-U2 /TAPE-U3 /TAPE-C5 /TAPE-C6/TAPE-U4/TAPE-U4E)

% MARM103 CONTINUE ACTION? REPLY (Y=YES; N=NO)?Y

LOCATION-ENTRIES:(LOCATION-NAME,SYMBOLIC-NAME,TYPE,OPERATING-MODE)
(ROBOTER1,ROBOTER1 ,LOCAL ,ROBAR-1 ) (CSTOR1 ,CSTOR1 ,LOCAL ,ROBAR-2 )
(CSTOR2 ,CSTORF ,LOCAL ,ROBAR-2 ) (CENTRAL ,CENTRAL ,LOCAL ,MANUAL )
(ROBABBA1,ROBABBA1 ,LOCAL ,ROBAR-1 ) (ROBABBA2,ROBABBA2,LOCAL ,ROBAR-1 )
( , , , ) ( , , , )
( , , , ) ( , , , )
( , , , ) ( , , , )
( , , , ) ( , , , )

% MARM103 CONTINUE ACTION? REPLY (Y=YES; N=NO)?N
```

- (1) The `MARENADM` administration program is called.
- (2) The new location with the name `ROBABBA1` is added to the `MAREN` storage location table. It is connected to one or more `BS2000` systems (default `TYPE=LOCAL`) and its symbolic name is also `ROBABBA1` (default `SYMBOLIC-NAME=*SAME`).
- (3) The `MAREN` parameters are output, including the storage location table. The storage location must also be inserted in the `MARENCP` enter file, otherwise it cannot be used. For more information, see the “`MAREN`” manual, volume 2 [8].

```
//MODIFY-VOLUME-ATTRIBUTES VOLUME=*INT(FROM=TAPE01,TO=TAPE10),LOCATION=
PAR(HOME-LOC=ROBABBA1,FREE-LOC=ROBABBA1,TEMPORARY-LOC=ROBABBA1) _____ (4)
//SHOW-VOLUME-ATTRIBUTES VOLUME=*INT(FROM=TAPE01,TO=TAPE10) _____ (5)
```

VOLUME	FSEQ	DEV-TYPE	CR-DATE	L-A-DATE	FREE-DATE	UA	E	REMARK (SHORTENED)
TAPE01	0001	TAPE-C4	<date>	<date>	<date>	AL		
TAPE02	0001	TAPE-C4	<date>	<date>	<date>	FR		TEST 01
TAPE03	0001	TAPE-C4	<date>	<date>	<date>	AL		
TAPE04	0001	TAPE-C4	<date>	<date>	<date>	AL		
TAPE09	0001	TAPE-C5	<date>	<date>	<date>	OW		MY PROGRAM
TAPE10	0001	TAPE-C5	<date>	<date>	<date>	AL		
%	MARM120	INSGESAMT	6	MAREN-KATALOGE	INTRAEGE	VERARBEITET		

```
//END _____ (6)
/ADD-DEVICE-DEPOT UNIT=(A1,A2,M1,M2),LOCATION=ROBABBA1 _____ (7)
/SHOW-DEVICE-DEPOT UNIT=*LOCATION(LOCATION=ROBABBA1) _____ (8)
```

```
LOCATION RTC TAPE-MNEMONICS
ROBABBA1 T A1,A2,M1,M2
```

- (4) The tapes are allocated to the location ROBABBA1 by means of their archive number range (TAPE01 to TAPE10).
- (5) Information from the MAREN catalog is output. Since a range of volume numbers was specified, only the most important catalog attributes are output for each tape.
- (6) The MARENADM administration program is terminated.
- (7) This operator command is used to allocate the required tape devices to the location already defined in MAREN.
- (8) The allocation between storage location, routing code and devices is output. The routing code output here indicates which console will display the messages required for the devices that are allocated to this storage location. The routing code T is set by default.

3.4.1.3 Execution of a mount request

You can issue the `SECURE-RESOURCE-ALLOCATION` command (see the “Commands” manuals [3]) when using the NDM device management system to reserve specific tape devices of storage locations. These locations must be the same as those from which the tapes are also selected for processing.

If you then wish to have a particular tape, e.g. the tape `TAPE01`, mounted on one of these devices. The figure 8 shows the sequence of operations involved in such a mount request. The mount request can be initiated, for example, by means of an `ARCHIVE` statement.

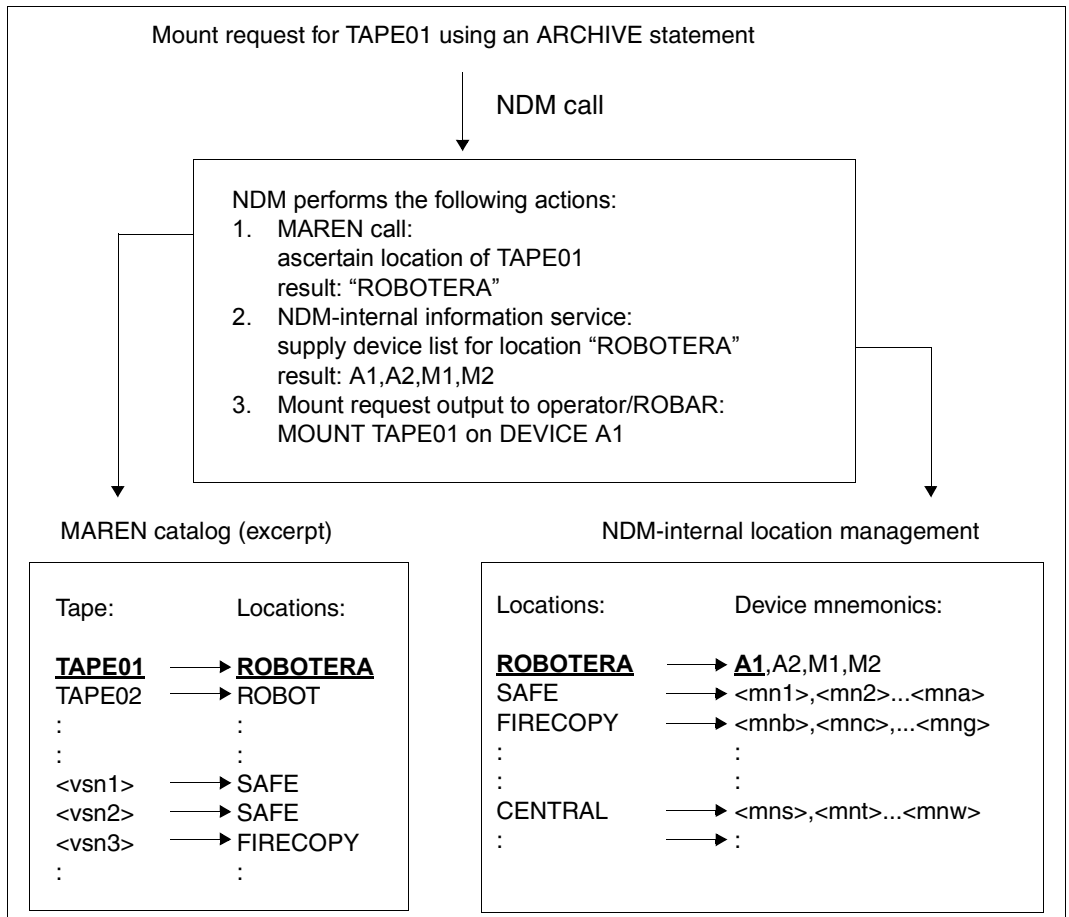

Figure 8: Sequence of operations for a mount request

The device management system reacts to this request as follows:

- Location definition for the tape
NDM ascertains via MAREN the location to which this VSN is allocated. If the VSN has been entered in the MAREN catalog, the associated location is used. Otherwise, MAREN returns a location determined via the MAREN exit routine or a default location.
- Device selection from a storage location
NDM uses the location returned by MAREN for the subsequent mount job. NDM selects a suitable free device at the location.
The location returned by MAREN is mandatory for NDM if it was made known to NDM using `ADD-DEVICE-DEPOT`. If NDM does not know the location, it accesses a device from those which have not been allocated to a location.

4 User interface for ROBAR-CL

In the BS2000 systems the ROBAR-CL-SDF user program passes organizational statements to ROBAR.

Organizational statements are:

- importing/exporting cartridges
- processing foreign cartridges (ABBA interface only)
- processing the ROBAR freepools (ABBA interface only)

ROBAR-CL-SDF has an SDF interface and can run in both interactive and batch mode. ROBAR-CL-SDF requires the user to be assigned the `TAPE-MANAGEMENT` privilege.

The program ROBAR-CL-SDF can only run with the associated syntax and message files. Information on installing these files is provided on [page 187](#).

The SDF syntax is provided in the “Commands” [3] manual.

Mode of operation of ROBAR-CL-SDF

On a BS2000 system there is generally only one instance of ROBAR-CL-SDF even if there are multiple ROBAR-CL-DCAM applications which are connected to different ROBAR-SV instances. A ROBAR-SV instance is identified by its location (`LOCATION` operand).

Each ROBAR-CL-SDF statement results in a message on the console (e.g. `ROB1050`) which is forwarded to all the ROBAR-SV instances affected and processed via the ROBAR rule files (RRFs).

If multiple ROBAR-SV instances are connected and a statement offers the `LOCATION` operand, this must also be specified explicitly in order to activate the ROBAR-SV instance addressed. See also the [section “Checking the value for the LOCATION operand” on page 96](#).

4.1 ROBAR-CL-SDF statements

The statements made to the ROBAR-CL-SDF user program are described in alphabetical order in the sections that follow.

The statement descriptions contain:

- functional description
- statement format
- description of the operands
- notes and examples

You may specify the following statements:

Statement	ROBAR messages	Meaning
ADD-ROBAR-VOLUME ¹	ROB1013	Supply position of a foreign cartridge
CREATE-ROBAR-FREEPOOL ¹	ROB1010	Create or extend ROBAR freepool
DELETE-ROBAR-FREEPOOL ¹	ROB1020	Release ROBAR freepool
EXPORT-ROBAR-VOLUME	ROB1030, ROB1031	Export cartridges
IMPORT-ROBAR-VOLUME	ROB1040	Import cartridges
REMOVE-ROBAR-VOLUME ¹	ROB1021	Release foreign cartridge
SHOW-ROBAR-VOLUME ¹	ROB1050	Issue information on current foreign cartridge storing positions to SYSOUT

¹ This statement has no meaning at the SCSI interface (Scalar i500, i2000 and i6000).

ROBAR-CL-SDF supports the SPIN-OFF mechanism.

In procedure and batch mode, after an erroneous statement, processing is continued with the statement that follows the next SET-JOB-STEP statement. If no SET-JOB-STEP statement is found, the program is terminated abnormally. In this case the message ROB1205 is issued instead of the message ROB1200. Therefore, you should include appropriate SET-JOB-STEP statements in existing procedure and batch files.

You can also use the standard SDF statements. They are not described in this manual. See the "SDF Dialog Interface" [9] manual for a description.

SDF allows suboperands to be entered directly as long as no ambiguity occurs as a consequence. E.g. //SHOW-ROBAR-VOLUME POSITION=1 is accepted and has the same meaning as //SHOW-ROBAR-VOLUME SELECT=*BY-POSITION(POSITION=1). However, it cannot be guaranteed that this alias will remain compatible in the future. We therefore recommend that you do not use it in procedures.

ADD-ROBAR-VOLUME

Supply position of a foreign cartridge

Application area: ABBA interface

The `ADD-ROBAR-VOLUME` statement supplies ROBAR with the position of a foreign cartridge in the foreign cartridge area of the input/output unit.

You can use this statement to prepare ROBAR for processing a foreign cartridge. In the mount operation ROBAR replaces the specified VSN with the position of the volume in the output unit. The allocation must be given at execution time.

ADD-ROBAR-VOLUME

VOLUME = <alphanum-name 1..6>

,**POSITION** = <integer 1..999>

,**ROB** = 1 / <integer 1..2> ¹

¹ Parameter obsolete. Can still be specified for reasons of compatibility.

VOLUME = <alphanum-name 1..6>

Archive number (VSN) of the foreign cartridge.

POSITION = <integer 1..999>

Storing position of the foreign cartridge in the foreign cartridge area of the input/output unit. The storing position must comprise three digits and must not be 000.

Notes

- If the optional `ROBAR_FOREIGN.<instance>` file does not exist, note that the robot mounts foreign cartridges stored in a given area in the input/output unit without checking their barcode label (if present); once these cartridges have been used, the robot returns them to their original position. This area must have been set up explicitly for foreign volumes in the archive system.
- If the foreign cartridge has a barcode label, it should be placed in the input area of the input/output unit and the `IMPORT-ROBAR-VOLUME` statement should be used if a dynamic area has been set up. `ADD-ROBAR-VOLUME` is intended specifically for cartridges without a barcode label or whose archive number is already known to the archive record.

- Please note the following if you are using MAREN: The MAREN administrator must add the foreign tape to the MAREN catalog with the following attributes, for example:

```
//IMPORT-FOREIGN-VOLUME VOLUME=FORE1,USER-ID=user-id,DEVICE-TYPE=TAPE-xx
//MODIFY-VOLUME-ATTRIBUTES VOLUME=FREMD1,
    LOCATION=PARAMETERS(HOME-LOCATION=xxx,
                        TEMP-LOCATION=xxx,
                        FREE-LOCATION=xxx)
```

where `user-id` is the user ID to which the tape is allocated and `xxx` is the storage location name that must correspond to the rules stipulated by MAREN.

- If the position of a foreign cartridge whose archive number is already recorded in the MAREN catalog is to be supplied, the cartridge in the archive is temporarily locked. This lock enables the new cartridge to be added. A third cartridge with the same archive number cannot be added until the second cartridge is released using the MAREN statement `EXPORT-VOLUME`.
- If a foreign cartridge has the same VSN as a cartridge already in the archive (home cartridge), a mount request for this VSN causes only to the foreign cartridge to be mounted. The home cartridge cannot be mounted until a `REMOVE-ROBAR-VOLUME` statement is entered.

Example

```
//ADD-ROBAR-VOLUME VOLUME=FORE1,POSITION=001
```

The cartridge with the VSN `FORE1` is located in storing position `001` of the foreign cartridge area of the input/output unit. If a mount request with `VOLUME=FORE1` is issued, ROBAR replaces the VSN in the mount request to the archive system with the symbolic VSN for this storing position (`*FR001`).

CREATE-ROBAR-FREEPOOL

Create freepool

Application area: ABBA interface

The CREATE-ROBAR-FREEPOOL statement supplies ROBAR with a list of archive numbers for scratch processing for the standard freepool or the task-specific freepool.

This statement has only been retained for reasons of compatibility. Its functionality is provided by the MAREN tape management system and MAREN should therefore be used.

You can use this statement to supply ROBAR with individual archive numbers or with an archive number range for global or task-specific processing of non-specific volume requests.

The archive numbers may be located in a file.

CREATE-ROBAR-FREEPOOL

POOL = STD / TSN

,VOLUME = <alphanum-name 1..6> / *INTERVAL(...) / *ALL(...)

*INTERVAL(...)

FROM = <alphanum-name 1..6>

,TO = <alphanum-name 1..6>

*ALL(...)

INPUT-FILE = <filename 1..54>

POOL = STD / TSN

Selects the standard or task-specific freepool.

VOLUME = <alphanum-name 1..6> / *INTERVAL(...) / *ALL(...)

Archive number (VSN) of the cartridges to be mounted in response to non-specific volume requests.

VOLUME = <alphanum-name 1..6>

Archive number of a cartridge to be added to the freepool.

VOLUME = *INTERVAL(...)

Sequence of archive numbers of cartridges to be exported in unbroken ascending order.

Note the following before entering numbers:

- the first and last archive number must be the same length
- the numeric field of each archive number must always occupy the same position in the number and must always be the same length
- the numeric field of the last archive number must be higher than that of the first

FROM = <alphanum-name 1..6>

First VSN in the range.

TO = <alphanum-name 1..6>

Last VSN in the range.

VOLUME = *ALL(...)

The archive numbers are transferred in a file with a variable record length. Each record includes an archive number at the beginning of the record. Alternatively *ALL can be entered.

INPUT-FILE = <filename 1..54>

Name of a SAM file with variable record length.

Notes

- You should not use `CREATE-ROBAR-FREEPOOL` if you are using MAREN, as this could lead to errors in operation.
- The ROBAR freepool contains the list of transferred archive numbers. You can select global (`POOL=STD`) or task-specific (`POOL=TSN`) allocation. If `POOL=TSN` is selected, the transferred archive numbers are allocated directly to the requesting task by way of the TSN; a task-specific freepool is created. The allocation is revoked after task execution.
- The organization of the free tapes with regard to ownership and expiration dates must be checked by the transferring task before this statement is issued. The listed volumes must be known to and available in the archive.
- The function of the freepool is activated in the ROBAR rule files by the keyword `DECLARE` (see [page 279](#)).
- You can create an input file using EDT, for example. Such a file must not contain more than 100 VSNs.
- After processing, you must release the task-specific freepool using `DELETE-ROBAR-FREEPOOL POOL=TSN` (see [page 86](#)).
- In the case of SCRATCH requests via ARCHIVE (when MAREN is not used), you are advised to set up an archive freepool with specific VSNs.

Example 1

```
//CREATE-ROBAR-FREEPOOL VOLUME=*INTERVAL(FROM=A10000,TO=A10099)
```

The 100 cartridges, beginning with the VSN A10000, are made available for global use in response to non-specific volume requests.

Example 2

```
//CREATE-ROBAR-FREEPOOL POOL=TSN,VOLUME=A20000
```

The cartridge with the VSN A20000 is allocated to the TSN of the task which has issued this ROBAR statement. A subsequent non-specific volume request under this TSN is allocated the volume A20000.

Example 3

```
//CREATE-ROBAR-FREEPOOL POOL=TSN,VOLUME=*ALL(INPUT-FILE=SCRATCHTAPES)
```

The archive numbers (A00010 to A00020) contained in the file SCRATCHTAPES are assigned for execution of non-specific volume requests to the task which has issued this ROBAR statement. The archive numbers are assigned by way of the TSN of the task.

Structure of the SCRATCHTAPES SAM file:

```
A00010  
A00011  
A00012  
A00013  
A00014  
A00015  
A00016  
A00017  
A00018  
A00019  
A00020
```

DELETE-ROBAR-FREEPOOL

Release task-specific freepool

Application area: ABBA interface

The DELETE-ROBAR-FREEPOOL statement releases the task-specific ROBAR freepool after SCRATCH processing.

You can use this statement to release unused archive numbers made available for task-specific processing by means of CREATE-ROBAR-FREEPOOL POOL=TSN. The allocation of archive numbers to the TSN of the requesting task is canceled when the task-specific freepool is deleted.

DELETE-ROBAR-FREEPOOL

Notes

The statement must be issued before the task has finished execution. If the allocation of TSN to archive numbers is not canceled, this freepool will continue to exist after the task has been completed. A new non-specific volume request with the same TSN would lead to the allocation of volumes which may still be in the freepool. Deletion is then only possible on the ROBAR server using the `rm` command.

Freepool files are contained in the following directory:

`/var/lib/robar_abba/<instance>/freepool/`

EXPORT-ROBAR-VOLUME

Export cartridges

Application area: SCSI and ABBA interface
(excluding ETERNUS CS)

This statement starts the export of cartridges to the input/output unit.

You can export your system's own cartridges or imported foreign cartridges at the ABBA interface, see [section "Exporting cartridges" on page 64](#).

You can use this statement to supply ROBAR with individual archive numbers or a range of archive numbers of cartridges to be removed from the archive.

EXPORT-ROBAR-VOLUME

```
VOLUME = <alphanum-name 1..6> / *INTERVAL(...)
  *INTERVAL(...)
    | FROM = <alphanum-name 1..6>
    | ,TO = <alphanum-name 1..6>
,ROB = 1 / <integer 1..2> 1
,KEEP-POSITION = *YES / *NO
,LOCATION = <alphanum-name 1..8> / *NOT-SPECIFIED
```

¹ Parameter obsolete. Can still be specified for reasons of compatibility.

VOLUME = <alphanum-name 1..6> / *INTERVAL(...)

Archive number (VSN) of the cartridge.

VOLUME = <alphanum-name 1..6>

Archive number of a cartridge.

VOLUME = *INTERVAL(...)

Sequence of archive numbers of cartridges to be exported in unbroken ascending order.

Note the following before entering numbers:

- the first and last archive number must be the same length
- the numeric field of each archive number must always occupy the same position in the number and must always be the same length
- the numeric field of the last archive number must be higher than that of the first.

FROM = <alphanum-name 1..6>

First VSN in the range.

TO = <alphanum-name 1..6>

Last VSN in the range.

KEEP-POSITION =

This parameter defines whether the archive record entry of the cartridge is deleted or retained. This operand has no meaning for the SCSI interface.

KEEP-POSITION = *YES

The archive record entry is retained.

KEEP-POSITION = *NO

The archive record entry is deleted.

LOCATION = <alphanum-name 1..8> / *NOT-SPECIFIED

Defines the storage location from which the cartridge is to be exported.

LOCATION = <alphanum-name 1..8>

Defines the storage location. You should use this specification if multiple ROBAR-SV instances are connected. Only the ROBAR-SV instance which administers the specified location will perform the statement. See also the [section “Checking the value for the LOCATION operand” on page 96](#).

LOCATION = *NOT-SPECIFIED

No storage location is defined.

This value makes sense only when only one ROBAR-SV instance is connected.

Notes

- If MAREN is being used, then you should use the MAREN statement `EXPORT-VOLUME` instead of this statement.
- ROBAR-CL informs MAREN as soon as the cartridge is exported so that the MAREN catalog is kept up-to-date:
 - If the exported cartridge is a foreign cartridge (`FOREIGN`), your entry is removed from the MAREN catalog
 - If the exported cartridge is a cartridge that is part of the MAREN Freepool, the temporary storage location of the cartridge (`TEMPORARY-LOCATION`) is changed to `CENTRAL`
 - In all other cases, the cartridge is flagged in the MAREN catalog as `EXPORTED BY ROBAR-SDF`.
- In the case of system cartridges (ABBA interface), the storing position in the archive remains reserved and appropriate information is entered in the archive record.

Examples

```
//EXPORT-ROB-VOL VOL=*INT(FROM=X00000,TO=X00009)
```

This statement starts the export for ten system cartridges, beginning with the VSN X00000.

```
//EXPORT-ROB-VOL VOL=FREMD7,KEEP-POS=NO
```

The cartridge FOR7 is to be placed in the output unit. The archive record is subsequently deleted.

IMPORT-ROBAR-VOLUME

Import cartridges

Application area: SCSI and ABBA interface
(excluding ETERNUS CS)

This statement starts the import of cartridges with a valid barcode label from the input/output unit, see [section “Importing cartridges” on page 62](#).

There is no need to specify archive numbers since all cartridges are identified by their barcode labels. The archive numbers of the imported cartridges are stored in the trace file of the ROBAR-SV instance (see [page 50](#)).

If MAREN is being used, ROBAR informs MAREN at the end of an import and issues the message ROB0037.

IMPORT-ROBAR-VOLUME
ROB = <u>1</u> / <integer 1..2> ¹
, LOCATION = <alphanum-name 1..8> / <u>*NOT-SPECIFIED</u>

¹ Parameter obsolete. Can still be specified for reasons of compatibility.

LOCATION = <alphanum-name 1..8> / *NOT-SPECIFIED

Defines the storage location to which the cartridge is to be imported.

LOCATION = <alphanum-name 1..8>

Defines the storage location. You should use this specification if multiple ROBAR-SV instances are connected. Only the ROBAR-SV instance which administers the specified location will perform the statement. See also the [section “Checking the value for the LOCATION operand” on page 96](#).

LOCATION = *NOT-SPECIFIED

No storage location is defined.

This value makes sense only when several ROBAR-SV instances are connected. All the archive systems import then the cartridges located in their input/output unit.

Notes

- The volumes must have been placed in the input/output unit before the statement is issued, see [page 62](#). The order in which they are placed there is not predefined. Cartridges which cannot be identified are not imported by the robot; they remain in the input/output unit.
- The MAREN administrator must add a foreign cartridge to the MAREN catalog with the following attributes:

```
//ADD-PRIVATE-VOLUME VOLUME=FORE1,USER-ID=user-id,DEVICE-TYPE=TAPE-xx
//MODIFY-VOLUME-ATTRIBUTES VOLUME=FORE1,
    LOCATION=PARAMETERS(HOME-LOCATION=xxx,
                        TEMP-LOCATION=xxx,
                        FREE-LOCATION=xxx)
```

where `user-id` is the user ID to be allocated to the tape and `xxx` is the storage location name that must correspond to the rules stipulated by MAREN.

If the VSN is not added to the MAREN catalog, inconsistencies occur between the archive record and the MAREN catalog.

Example

```
//IMPORT-ROBAR-VOLUME LOCATION=ROBOT1
```

This statement starts the import for all cartridges located in the input area of the input/output unit of the storage location `ROBOT1`.

REMOVE-ROBAR-VOLUME

Release foreign cartridge

Application area: ABBA interface

The REMOVE-ROBAR-VOLUME statement releases a foreign cartridge which is located in the foreign cartridge area of the input/output unit.

Once the foreign cartridges have been processed, you use this statement to cancel the allocations that were made using ADD-ROBAR-VOLUME.

REMOVE-ROBAR-VOLUME
VOLUME = <alphanum-name 1..6>
, LOCATION = <alphanum-name 1..8> / <u>*NOT-SPECIFIED</u>

VOLUME = <alphanum-name 1..6>

Archive number (VSN) of the foreign cartridge.

LOCATION = <alphanum-name 1..8> / *NOT-SPECIFIED

Defines the storage location for which the cartridge is to be released.

LOCATION = <alphanum-name 1..8>

Name of the storage location for which the cartridge is to be released.

You should use this specification if multiple ROBAR-SV instances are connected. Only the ROBAR-SV instance which administers the specified location will perform the statement.

See also the [section "Checking the value for the LOCATION operand" on page 96](#).

LOCATION = *NOT-SPECIFIED

No storage location is defined.

This value makes sense only when only one ROBAR-SV instance is connected.

Example

```
//REMOVE-ROBAR-VOLUME VOLUME=FOREIGN1
```

The statement deletes the allocation of storing position to archive number of the cartridge FOREIGN1.

SHOW-ROBAR-VOLUME

Displays information on foreign cartridge storing positions

Application area: ABBA interface

This statement issues information on cartridges in foreign cartridge storing positions. The information is issued to SYSOUT.

The `ROBAR_FOREIGN.<instance>` file defined for the ROBAR-SV instance is a prerequisite for obtaining correct information.

SHOW-ROBAR-VOLUME

SELECT = *ALL / *BY-POSITION (...) / *BY-VOLUME (...)

***BY-POSITION (...)**

POSITION = <integer 1..999>

***BY-VOLUME (...)**

VOLUME = <alphanum-name 1..6>

,LOCATION = <alphanum-name 1..8> / *NOT-SPECIFIED

SELECT = *ALL / *BY-POSITION (...) / *BY-VOLUME (...)

Specifies on which cartridges information is to be issued.

SELECT = *ALL

Information concerning all cartridges in foreign cartridge positions is requested.

SELECT = *BY-POSITION (POSITION=<integer 1..999>)

Information is requested on the cartridges in the specified foreign cartridge storing positions.

SELECT = *BY-VOLUME (VOLUME = <alphanum-name 1..6>)

Information is requested on the specified cartridge.

LOCATION = <alphanum-name 1..8> / *NOT-SPECIFIED

Defines the storage location for which information is to be output.

LOCATION = <alphanum-name 1..8>

Name of the storage location for which information is to be output.

You should use this specification if multiple ROBAR-SV instances are connected. Only the ROBAR-SV instance which administers the specified location will perform the statement.

See also the [section "Checking the value for the LOCATION operand" on page 96](#).

LOCATION = *NOT-SPECIFIED

No storage location is defined.

This value makes sense only when several ROBAR-SV instances are connected.

Information is then output for all storage locations.

Example

```
//show-robar-volume location=robabba1 _____ (1)
% ROB1110 COMMAND ACCEPTED
VSN      Position  Coordinate
-----
ARC607   *FR001     -
TST001   *FR002     - _____ (2)
-----   *FR003     -
TAPEHO   *FR004     00030104
-----   *FR005     00030105 _____ (3)
-DAS--   *FR006     00030106
% ROB1111 END OF FOREIGN VOLUME DEFINITIONS FOR SELECTION=*ALL AND
LOCATION=ROBABBA1 _____ (4)

//show-robar-volume volume=tst001 _____ (5)
% ROB1110 COMMAND ACCEPTED
VSN      Position  Coordinate
-----
TST001   *FR002     -
% ROB1111 END OF FOREIGN VOLUME DEFINITIONS FOR SELECTION=VOLUME:TST001
AND LOCATION=*NOT-SPECIFIED _____ (6)
```

- (1) Information concerning the storage location ROBABBA1 is requested.
- (2) Positions *FR001 to *FR003 are reserved for ROBAR; the position is not to be shared with DAS.
- (3) Positions *FR004 to *FR006 are shared with DAS (position *FR004 is used by ROBAR (volume TAPEHO), position *FR005 is free, position *FR006 is used by DAS and is not available to ROBAR).
- (4) The information requested was issued.
- (5) Information on the cartridge TST001 is requested.
- (6) The information requested was issued.

```
//show-robar-volume position=005 ----- (7)
% ROB1110 COMMAND ACCEPTED
VSN      Position  Coordinate
-----
----- *FR005      00030105
% ROB1111 END OF FOREIGN VOLUME DEFINITIONS FOR SELECTION=POSITION:005
AND LOCATION=*NOT-SPECIFIED ----- (8)

//show-robar-volume volume=tototo ----- (9)
% ROB1110 COMMAND ACCEPTED
% ROB1112 NO FOREIGN VOLUME DEFINITION EXISTS DEFINITIONS FOR
SELECTION=VOLUME:TOTOTO AND LOCATION=*NOT-SPECIFIED ----- (10)
```

- (7) Information on the foreign cartridge storing position 005 is requested.
- (8) The information requested was issued.
- (9) Information on the cartridge TOTOTO is requested.
- (10) The cartridge does not exist and a message to that effect is issued.

4.2 Checking the value for the LOCATION operand

When multiple storage locations which are administered by different ROBAR-SV instances exist, the `LOCATION` operand should always be specified in the ROBAR-SDF statements with reference to a location. Otherwise each ROBAR-SV instance would attempt to execute the statement. This can lead to incorrect results and an inconsistent archive. Furthermore, MAREN is placed in an inconsistent state.

To prevent this, you must also modify the ROBAR rule files (RRFs) so that the ROBAR-SDF statements can be processed as required. The aim is to ensure that outstanding ROBAR-SDF requests are processed only by the ROBAR-SV instance for which they are intended. The ROBAR-SV instance is identified by means of the `LOCATION` operand.

Details on the ROBAR rule files are provided in [chapter “ROBAR rule files” on page 247](#).

There are a number of appropriate entries in the `message_file` and `message_xref` ROBAR rule files for all messages received from ROBAR-CL-SDF that originate in a statement containing the `LOCATION` operand. The appropriate entry is determined with the aid of the specified value for `LOCATION`.

1. The first entry in the `message_file` ROBAR rule file refers to the storage location name of the current ROBAR-SV instance. The value for the storage location is initially `11111111`.
The entry is selected when the user explicitly specifies the storage location of this ROBAR-SV instance in the ROBAR-CL-SDF statement.

Example

The storage location is `ROBABBA1`.

The following statement is entered: `//SHOW-ROBAR-VOLUME LOCATION=ROBABBA1`.

The message `ROB1050` is displayed on the console.

This leads to the following entry being processed in the RRF file `message_file`:

```
:*MF360: ?ROB1050 *ALL *ALL 11111111 hhh
```

2. Entry if no storage location was specified for the ROBAR-CL-SDF statement (`LOCATION=*NOT-SPECIFIED`).

Example

`SHOW-ROBAR-VOLUME`

This leads to the following entry being processed in the RRF file `message_file`:

```
:*MF361: ?ROB1050 *ALL *ALL *NO hhh
```

3. Entry if a further ROBAR instance is connected to the BS2000 system. This ROBAR instance corresponds to another storage location which must be entered in the RRF file `message_file`.

The ROBAR rule file `message_xref` contains the `WAIT 0` code for that purpose, i.e. the current ROBAR-SV instance does not have to become active, because another instance of ROBAR-SV is handling the message.

Example

```
SHOW-ROBAR-VOLUME LOCATION=ROBABBA2
```

The following entry in the RRF file `message_file` is processed after the value `LOCATION` of the RRF file supplied has been replaced by `ROBABBA2` before the ROBAR-SV instance starts:

```
 :*MF362: ?ROB1050 *ALL *ALL ROBABBA2
```

If further ROBAR-SV instances are connected to the BS2000 system, further entries must be generated in the RRF file `message_file` with the corresponding entries in the RRF file `message_xref`, e.g.:

```
 :*MF363: ?ROB1050 *ALL *ALL AILLEURS
 :*MF364: ?ROB1050 *ALL *ALL PATOUCHE
 ...
```

In this case the corresponding entries must be made in the RRF file `message_xref`, e.g.:

```
 :*MF363 MR200 (WAIT 0)
 :*MF364 MR200 (WAIT 0)
 ...
```

4. Entry if a non-existent location is specified.
This entry may be activated only in one of the ROBAR instances involved so that only one ROBAR-SV instance responds to the message (in the negative).

Example

```
SHOW-ROBAR-VOLUME LOCATION=WRONGLOC
```

This leads to the following entry being processed in the RRF file `message_file`:

```
 :*MF36Z: ?ROB1050 *ALL *ALL /
```

By default, the entries are configured in the ROBAR rule file for just one ROBAR-SV instance. I.e. the first, the second and the last entry are activated in `message_file`. The entry for a further ROBAR instance exists as a comment.

Example

```
 :*MF360: ?ROB1050 *ALL *ALL 11111111 hhh
 :*MF361: ?ROB1050 *ALL *ALL *NO hhh
 /*MF362: ?ROB1050 *ALL *ALL LOCATION
 :*MF36Z: ?ROB1050 *ALL *ALL /
```

If you are using several ROBAR instances, observe the following:

- The entry for further ROBAR instances (in the example MF362) has to be activated by removing the comment characters. The term `LOCATION` has to be replaced by the actual name of the storage location of the additional ROBAR instance.
- The entry for storage locations that are not specified (`*NO`, in the example MF361) has to be deactivated.
- If further ROBAR-SV instances are connected to the BS2000 system, further entries must be generated in the RRF file `message_file` with the corresponding entries in the RRF file `message_xref`.
- The last entry may only be activated in one ROBAR-SV instance. It has to be deactivated in all other instances.



All entries contained in the ROBAR rule file `message_file` for ROBAR-CL-SDF statements referring to a storage location have to be adjusted. This applies to the following entries in the standard ROBAR rule file:

```
MF32x (//REMOVE-ROBAR-VOLUME)
MF33x (//EXPORT-ROBAR-VOLUME KEEP-POSITION=*NO)
MF34x (//EXPORT-ROBAR-VOLUME KEEP-POSITION=*YES)
MF35x (//IMPORT-ROBAR-VOLUME)
MF36x (//SHOW-ROBAR-VOLUME SELECT=*ALL)
MF37x (//SHOW-ROBAR-VOLUME SELECT=*BY-POSITION)
MF38x (//SHOW-ROBAR-VOLUME SELECT=*BY-VOLUME)
```

This example illustrates on the basis of MF36x entries which adjustments have to be made in the `message_file` ROBAR rule file.

Example for two storage locations

One ROBAR-SV instance exists for each of the storage locations `ROBABBA1` and `ROBABBA2`. The relevant `message_file` looks like this for the `SHOW-ROBAR-VOLUME` statement:

- First ROBAR-SV instance with storage position `ROBABBA1`

```
:*:MF360: ?ROB1050 *ALL *ALL 11111111 hhh
/*:MF361: ?ROB1050 *ALL *ALL *NO hhh
*:MF362: ?ROB1050 *ALL *ALL ROBABBA2
*:MF36Z: ?ROB1050 *ALL *ALL /
```

 - Since several ROBAR-SV instances exist, `LOCATION=*NOT-SPECIFIED` is not allowed. Consequently, the entry MF361 has been deactivated.
 - The entry MF362 has been activated by replacing the leading `/` by `:` and by replacing `LOCATION` by `ROBABBA2` (storage location of the other ROBAR-SV instance).

- **Second ROBAR-SV instance with storage position ROBABBA2**
 - :*:MF360: ?ROB1050 *ALL *ALL 11111111 hhh
 - /*:MF361: ?ROB1050 *ALL *ALL *NO hhh
 - :*:MF362: ?ROB1050 *ALL *ALL ROBABBA1
 - /*:MF36Z: ?ROB1050 *ALL *ALL /
- Since several ROBAR-SV instances exist, LOCATION=*NOT-SPECIFIED is not allowed. Consequently, the entry MF361 has been deactivated.
- The entry MF362 has been activated by replacing the leading / by : and by replacing LOCATION by ROBABBA1 (storage location of the other ROBAR-SV instance).
- The entry MF36Z has been deactivated by replacing the leading : by /.

5 User interface for ROBAR-SV

ROBAR-SV has in ongoing operation the task of receiving mount jobs from the BS2000 systems in the form of messages, evaluating these and passing them in the form of control statements to the archive system.

In addition, the ROBAR-SV Manager and the `robar` menu program on the ROBAR server are largely user interfaces with identical functions for the ROBAR administrators and ROBAR operators. They enable you, for example, to start, monitor and terminate the ROBAR-SV instances.



Use of the ROBAR-SV Manager is recommended.

The `robar` menu program contains a few, more in-depth functions which are not mapped in the ROBAR-SV Manager. For these functions the ROBAR-SV Manager consequently also incorporates a call for the `robar` menu program.

The `robar` menu program can also be called separately in a Linux shell on the ROBAR server. It also offers the complete functional scope, but is not so user-friendly as the ROBAR-SV Manager.

This chapter describes how you operate ROBAR-SV using the ROBAR-SV Manager and the `robar` menu program.

5.1 Operation using the ROBAR-SV Manager

The ROBAR-SV Manager is a web application.

In order to use this web application from an administration PC, you need a network connection to the ROBAR server, and a browser must be installed. Microsoft Internet Explorer and Mozilla Firefox are supported. The version dependencies are described in the ROBAR Release Notice.

The browser on the administration PC must satisfy the following requirements:

- It is permissible to execute JavaScript
- Cookies are permitted

The languages of the ROBAR-SV Manager are English and German. You can switch languages using the language option in the header area.

Special aspects when working on SE servers

- On SE servers the ROBAR-SV Manager is also available as an add-on pack in the SE Manager. A few special aspects must be taken into consideration when working with the ROBAR-SV Manager on SE servers, see [page 105](#).
- Information on and actions for the ROBAR-SV Manager are available in the SE Manager when the ROBAR-SV Manager is installed as a ROBAR add-on pack (see the "Operation and Administration" manual [[14](#)]):
 - ▶ Select the relevant server in the *Hardware* area of the den SE Manager. There select the *Service* function In the *Update* tab, the information on the actions for the ROBAR-SV Manager is displayed in the add-on pack area.
 - ▶ In the *Logging* area of the SE Manager, select the *Audit Logging* tab. Entries for important actions are generated there by the ROBAR-SV Manager.
- In SE server installations, the `max_trace_file_age=30` parameter is set by default in the global configuration file of ROBAR-SV, see [page 210](#).
- In SE server installations the `robaradm` and `robarsv` user groups and the `robar` user have the following fixed user IDs. These are also retained after new installations or updates.
 - User `robar`: Id 860
 - User group `robarsv`: Id 860
 - User group `robaradm`: Id 865
- In SE server installations, the storage space occupied by the ROBAR instances is monitored periodically using a script and optimized if necessary, see [page 56](#).
- The "Configuration Save and Restore" (CSR) function of the SE Manager (see the "Operation and Administration" manual [[14](#)]) takes into account the ROBAR configuration when ROBAR-SV is installed in the SE Manager as an add-on pack:
 - When a configuration backup with CSR takes place, a (ROBAR) backup archive containing the current ROBAR configuration files is created automatically (by analogy to the description on [page 142](#)). An existing ROBAR backup archive is overwritten. The automatically created ROBAR backup archive is transferred to the CSR backup archive.
 - In the event of restoral with CSR, the ROBAR backup archive is restored from the CSR backup archive. An existing ROBAR backup archive is overwritten. The restored ROBAR backup archive can then be used in the ROBAR-SV Manager to restoring the ROBAR configuration files, see [page 142](#).

- In the event of a software update of ROBAR-SV or the carrier system, CSR makes the ROBAR backup archive stored most recently available to ROBAR-SV. ROBAR-SV takes this ROBAR backup archive into consideration when restoring its configuration files provided no more recent ROBAR backup archive exists.



When ROBAR-SV is installed or updated, CSR supplies ROBAR-SV with the ROBAR backup archive stored most recently only if a CSR configuration backup which contains the ROBAR backup archive was performed **beforehand**.

When the carrier system is updated, CSR restoral is **automatically** performed. In this case CSR supplies ROBAR-SV with the ROBAR backup must recently stored, provided this is available.

The CSR backup then incorporates a ROBAR backup archive if the ROBAR add-on pack is correctly installed and a ROBAR backup archive can be provided at the time the CSR backup takes place.

5.1.1 Calling the ROBAR-SV Manager

The ROBAR-SV Manager is available in two variants:

- On all server series in the standalone variant
- On SE servers also as an add-on pack for the SE Manager

5.1.1.1 Calling the standalone variant (all server series)

- ▶ Set up a secure connection to the ROBAR server in your browser. To do this, enter the name or the IP address of the ROBAR server, followed by `/robar`, in the address bar of the browser, e.g. `https://172.17.64.86/robar`.



If you are working locally on the ROBAR server, the address is `https://localhost/robar`.

- ▶ Press the **ENTER** key.



If the browser now displays a warning about the security certificate, click *Continue to this website*.

The connection is set up. The login window is opened.



The web access to the ROBAR server is installed when ROBAR-SV is installed on the ROBAR server.

5.1.1.2 Calling the add-on pack for the SE Manager (SE servers)

- ▶ Start the SE Manager and log in.

How to work with the SE server is described in the online help for the SE Manager and in the "Operation and Administration" manual [14].

- ▶ In the SE Manager's main window select the menu *Applications > ROBAR*.



To obtain access to the ROBAR-SV Manager you must be a member of one of the following user groups:

1. User group administrator or operator of the SE Manager or a user group which is permitted to access the ROBAR-SV Manager
2. User group ROBAR administrator (`robaradm`) or ROBAR operator (`robarsv`), see [page 39](#)

Otherwise access is rejected.

No Login window is displayed as in the standalone variant (see [page 106](#)).

Group affiliation is sufficient to log in.

- ▶ Following a successful login, the main window of the ROBAR-SV Manager appears, see [page 109](#).

Special aspects when working with the add-on pack

Working with the add-on pack differs from working with the standalone software of the ROBAR-SV Manager:

- In the tree structure of the main window (see [page 110](#)) you will find the < **SE Manager** entry at the top which enables you to return to the SE Manager.

When you return to the SE Manager, you are taken to the screen in the SE Manager which you selected last.

- The ROBAR-SV Manager always uses the SE Manager's language setting, session timeout value and update cycle. You cannot modify these settings in the ROBAR-SV Manager.

The language option is consequently not contained in the header area of the main window.

For the ROBAR administrator only the *Global configuration file* and *Backup of configuration files* areas appear in the *Management > Configuration* menu, *Global configuration* tab.

The *Management > Configuration* menu is not available to the ROBAR operator.

- The *Certificates* tab is missing from the *Management > Authorizations* menu. This function is offered by the SE Manager.
- CMX partner names which begin with the following strings cannot be used as CMX partners:
 - DSS
 - LBSVM
 - MANLO
 - \$CONS
 - \$KVM

These partner names are reserved for the SE Manager. They are not displayed in the *Management > Configuration* menu, *CMX configuration* tab. They can also not be used in the wizard to configure a new instance or in the dialog for adding a new CMX partner.

- When you log out from the ROBAR-SV Manager (see [page 107](#)), you also implicitly log out from the SE Manager.

5.1.2 Logging in

Access to the ROBAR-SV Manager is protected.

You must log in with your account and the associated password. This only applies for the standalone variant, see [page 104](#).

The login window provides access to the web application. It has a different format from the other windows:

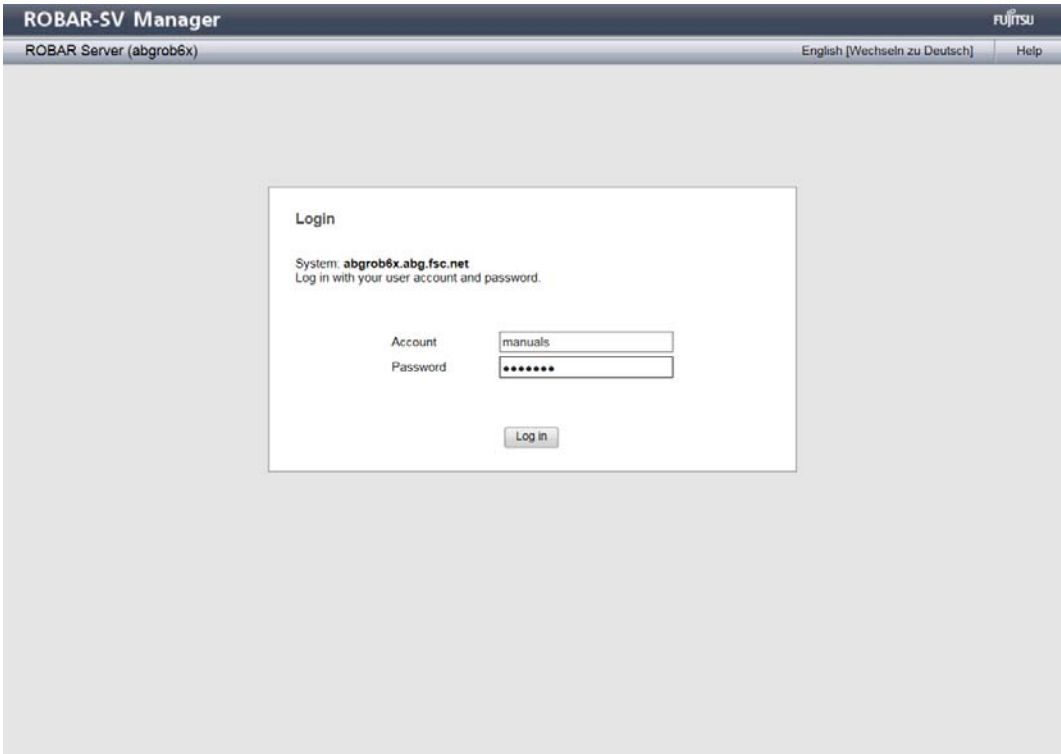

Proceed as follows to log in on the ROBAR-SV Manager:

- ▶ Enter your account.
- ▶ Enter your password.



The account and the password are case-sensitive.

- ▶ Click *Log in*.



After ROBAR-SV has been installed, the user groups `robaradm` and `robarsv` and the user `robar` are configured, see [page 209](#).

Following a successful login, the main window of the ROBAR-SV Manager opens, see [page 109](#).

5.1.3 Logging out

Proceed as follows to log out from the ROBAR-SV Manager:

- ▶ Click *Log out* (in the header area of the main window).
See section “[Main window](#)” on [page 109](#).

The login window appears. This applies for the standalone variant, see [page 104](#). In the ROBAR add-on pack, this also logs you out from the SE Manager.

5.1.4 Session management

When you log in on the ROBAR-SV Manager, a session with a unique session ID is set up. The server regards all requests with the same session ID as connected and are assigned to your account.

5.1.4.1 Session timeout (standalone variant)

You click *Log out* in the header area of the main window to terminate the current session explicitly.

If you do not log out explicitly, the session can terminate if there is no activity for a specified time, i.e. if the ROBAR-SV Manager registers no action in this time.

If you click a menu item after the session has terminated, the login window opens and you must log in again.

If you start an action in the work area after the session has terminated, a dialog opens containing the following message:

The action could not be executed. Your session has expired. Please, sign in again.

The login window appears after the dialog closes. See [section “The dialog” on page 111](#).

The value for the session timeout can be set on a user-specific basis in the ROBAR-SV Manager, see [section “Setting the session timeout value on a user-specific basis” on page 143](#).

5.1.4.2 Automatic update (standalone variant)

The automatic update ensures that the data displayed in the main window is up to date. All the data displayed is updated in each cycle, in particular:

- the object lists and their statuses in the working area
- the object lists and their statuses in the tree structure

While an automatic update is running, the update icon (rotating wheel) on the right-hand edge of the tabs shows this.

The value for the automatic update can be set in the ROBAR-SV Manager, see [section “Setting the automatic update on a user-specific basis” on page 143](#).



The automatic update does not prevent the session from aging. Even after the session has expired, automatic updating continues. Only an explicit mouse click causes the login page to be called.

Suspending the automatic update

As soon as you change the displayed data (filter, sort, expand a line, click on a selection field), the automatic update is suspended.

The suspended update is indicated by the fixed icon on the right-hand edge of the tabs. When you click this icon, the page is refreshed and the automatic update is resumed. All changes which you have made on this page are then lost (e.g. filter set, selection fields selected).

5.1.4.3 Loss of connection

If the connection to the system is lost (e.g. as a result of a system reboot), this is displayed in an information box on the right-hand edge of the tabs (in the vicinity of the update icon). Monitoring is resumed, and re-establishment of the connection is also displayed there.

Only when the page is explicitly refreshed or the information box is clicked is the information box deleted.

5.1.5 ROBAR-SV Manager interface

The sections below describe the interface of the ROBAR-SV Manager and introduce terms which are used in the manual.

5.1.5.1 Window types

Various window types are used in the ROBAR-SV Manager:

- The login window: a window in which you log in using your account and password. See [section “Logging in” on page 106](#).
- The main window: a window which is always visible between logging in and logging out on the ROBAR-SV Manager; it contains the navigation elements and the work area in which information is output and actions are initiated. See [section “Main window” on page 109](#).
- The action window: a window which opens when an action starts and closes again after the action has been completed. It is also used to output error messages. See [section “The dialog” on page 111](#).
- The online help window: a window which opens when the online help is called. See [section “Calling the online help” on page 116](#).

5.1.5.2 Main window

The main window of the ROBAR-SV Manager opens as soon as you have logged in on the ROBAR-SV Manager. It has the following layout:

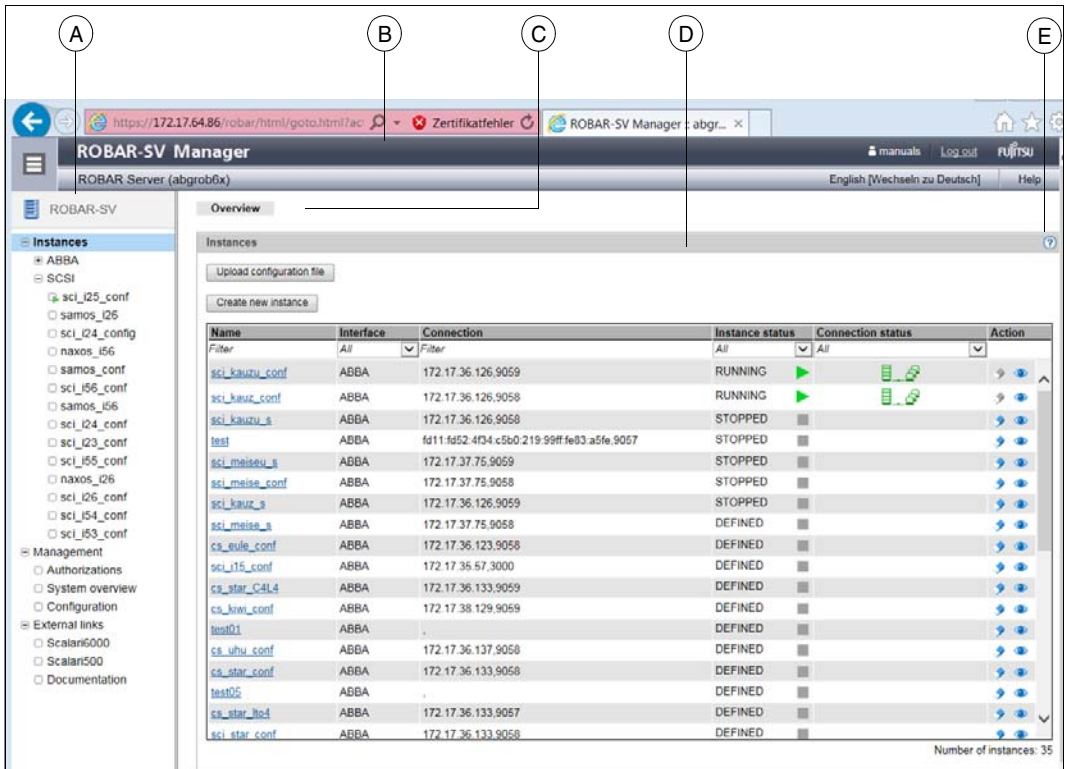

A	Primary navigation	For selecting an object or function. A green triangle indicates ROBAR-SV instances which are in the RUNNING state.
B	Header area	General ROBAR-SV information: user's account, <i>Log out</i> button, language option (English/German), <i>Help</i> button for calling the homepage of the online help (see page 116). When the user variables <code>SYSNAME</code> and <code>SYSLOCATION</code> are defined in the SNMP configuration file <code>/etc/snmp/snmpd.conf</code> , they are output in the header area under ROBAR-SV Manager .
C	Secondary navigation	For selecting the desired tab
D	Work area	The work area can contain several areas. Each area is framed and has a header. In the work area: – data is displayed (as a rule in tables) – actions are initiated (by means of action icons or buttons)
E	Action icon "?"	Icon for calling the context-sensitive online help (see page 116)

5.1.5.3 The dialog

A dialog opens as soon as you start an action:

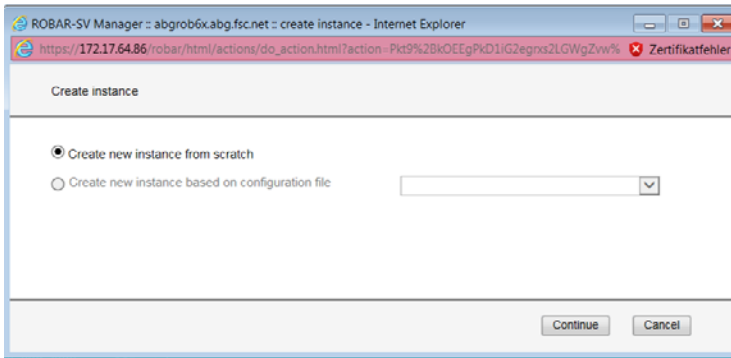

A dialog comprises:

- Title bar: general information.
- Header area: information on the action
- Parameter area (optional): fields for entering or selecting parameter values. The possible values, maximum character length and permissible characters are explained next to the fields.
- Area with the labeled buttons, e.g. *Continue* and *Cancel*.

In a simple dialog with an empty parameter area you only confirm the action called. Alternatively you can also cancel the action.



This confirmation of actions is not mentioned in the descriptions of procedures in this manual.

However, you often enter data in the parameter area or confirm default values.

Only after all the values have been entered directly or step by step do you execute the action (or cancel it).

The ROBAR-SV Manager checks your input and reacts to illegal or missing entries by issuing error messages or markings in the dialog. The ROBAR-SV Manager also reports successful execution of the action in the dialog.

While the ROBAR-SV Manager executes an action, *Please wait* is displayed in the parameter area.

After an action has been executed, you click the *Close* button to close the dialog. The tables in the ROBAR-SV Manager's work area are then updated. If you close the dialog differently, the work area in the main window is not updated. You can press function key *F5* to update the ROBAR-SV Manager manually. Not every action modifies the table contents.



Do not close the dialog using the close function in the browser window because the work area is then not updated immediately. The browser functionality should never be used in dialogs.

The [section “Executing an action” on page 115](#) describes what you must take into account when executing an action.

5.1.6 Calling an object or function in the ROBAR-SV Manager

Proceed as follows to call a function area in the ROBAR-SV Manager:

- ▶ Select an object or function in the primary navigation by clicking it.

One or more associated tabs open. Tabs which cannot be selected are displayed in grey.

In the work area the content which belongs to the function area of the first tab is displayed in one or more tables. Buttons or action icons may also be available to execute actions.

- ▶ If required, select another tab by clicking it.

The content of the work area changes if you select another tab.

- ▶ Alternatively to the procedure described above, you can also select a tab directly via the tool tip in the tree structure:
Drag the mouse cursor over the functions and objects displayed in the tree structure. Tool tips with the available tabs are displayed. Click on the required tab to switch straight to it.

The selected menu item and the selected tab are highlighted by being displayed in bold black against a gray background.

Example (selection via tree structure and tabs)

Instances, BS2000 hosts & Library tab

Instances corresponds to a selection in the primary navigation or tree structure,

BS2000 hosts & Library to a selection in the secondary navigation, which is also referred to as a tab.

The screenshot shows the ROBAR-SV Manager interface. The top navigation bar includes 'ROBAR-SV Manager', 'ROBAR Server (abgro65x)', 'manuals', 'Log out', 'FUJITSU', and 'English [Wechseln zu Deutsch] Help'. The left sidebar shows a tree structure under 'ROBAR-SV' with 'Instances' expanded to show 'sci_i25_conf' selected. The main content area has tabs for 'Operation', 'BS2000 hosts & Library', 'Messages & Devices', 'Logging files', and 'Diagnostics'. The 'BS2000 hosts & Library' tab is active, displaying 'Library information' and 'Status of instance sci_i25_conf'. The 'Library information' table shows details for the ROBAR interface, connection, location, and archive type. The 'Status of instance sci_i25_conf' diagram shows 'BS2000 hosts' (1 green, 3 grey), 'Instance sci_i25_conf' (running), and 'Library' (AMU1 and Robot1, both green). Below this is a table for 'BS2000 host status (Notification host: 411)' with columns for Host alias, IP address, FQDN, DCAM application, MAREN host, and Connection status.

Host alias	IP address	FQDN	DCAM application	MAREN host	Connection status
				All	All

Example (direct selection via tool tip)

The tool tip appears when you move the mouse cursor over the object. Clicking on the tabs offered in the tool tip enables you to select a tab directly.

The screenshot shows the ROBAR-SV Manager interface. The left sidebar contains a tree view of instances, with 'sci_i25_conf' selected. The main window displays the 'Library information' for 'sci_i25_conf', including fields for Location (ROB125), Archive type (scsi-1), and Information (This is a test for the sci_i25_conf file maybe it works or maybe not1234567890). Below this is a 'Status of instance sci_i25_conf' diagram showing 'BS2000 hosts' (1 green, 3 grey), 'Instance sci_i25_conf' (running), and 'Library' (AMU1 and Robot1, both green). At the bottom, there is a table for 'BS2000 host status (Notification host: 411)' with columns for Host alias, IP address, FQDN, DCAM application, MAREN host, and Connection status.

Host alias	IP address	FQDN	DCAM application	MAREN host	Connection status
S43	172.17.66.170	abond403.abo.fsc.net	ROBAR25K	No	All

5.1.7 Navigation

You can switch between the function areas as you require by clicking menu items and tabs. You can also use the browser functions to navigate forward and backward and to update the main window.

Some functions of the ROBAR-SV Manager open a new browser window or a new browser tab.

5.1.8 Filtering a table

Filters make it easier to handle extensive tables.

In tables which are already displayed, free text and selection menu filters enable you to restrict the data which is currently displayed in the table columns.



The automatic update is suspended by filtering (see [section "Automatic update \(standalone variant\)" on page 108](#)).

5.1.9 Sorting a table

Proceed as follows to sort a table:

- ▶ Drag the mouse cursor over the column headings in the table.
When the mouse cursor turns into a symbolic hand, you can sort the table according to the values of this column.
- ▶ Click the column heading.

The table is sorted.

If you click on the same column heading again, the sort order changes from ascending to descending or vice versa.

Sorting according to a different column cancels the previous sort order.



The automatic update is suspended by sorting (see [section “Automatic update \(standalone variant\)” on page 108](#)).

5.1.10 Executing an action

This section describes how an action is typically executed.

You start an action in the ROBAR-SV Manager's work area.

Two options are available after you have selected a function area:

- ▶ Click a labeled button.
Active buttons are colored gray.
- ▶ Click an action icon in a table (e.g. *Change*, *Delete*).
Active action icons are colored blue.
Action icons always belong to a particular record (of a table row) and are therefore contained in this table row. Each action icon stands for a particular task which you can execute.

After you have started the action, a dialog opens.

See the [section “The dialog” on page 111](#) for the layout.

Some buttons and action icons are not always available. These are then inactive and are colored light gray.

5.1.11 Calling the online help

The ROBAR-SV Manager incorporates an integrated, context-sensitive online help.

The online help contains information on all function areas of the ROBAR-SV Manager.

There are two ways to call the online help (see [page 109](#)):

1. By means of the *Help* function in the header area of the ROBAR-SV Manager:
The homepage of the online help is called in a new browser window.
2. By means of the *Help* action icon in the work area:
the relevant section of the online help (topic-related) is opened in a new browser window. You are given information on the functionality of the current window.

The figure below shows a page of the online help:

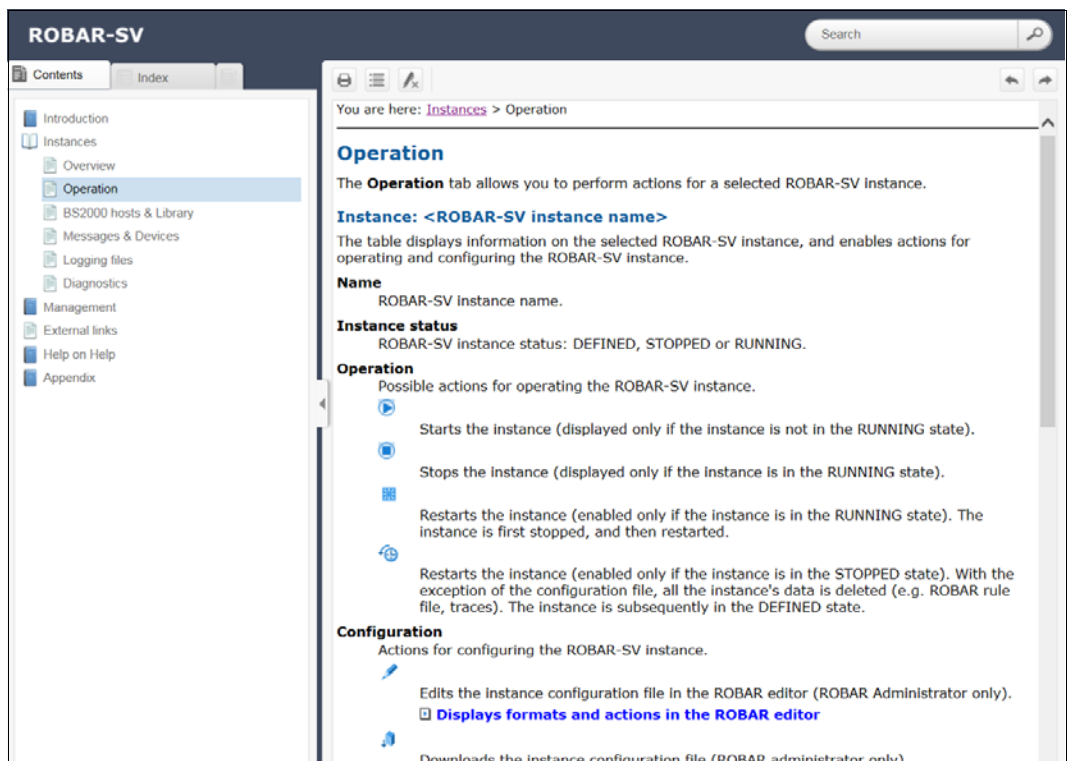

The area on the left contains the table of contents, which is structured in a similar way to the primary and secondary navigation of the ROBAR-SV Manager.

The content selected is displayed on the right. The area on the left can be expanded and collapsed to accommodate size of the content area.

You can, for instance, print the contents displayed (printer icon at the top right).

You can also have the index or glossary displayed in the area on the left instead of the table of contents.

You can navigate and search in the entire online help irrespective of how it was called.

The content of the online help is also supplied as a PDF file. You will find the PDF file under *Appendix* in the online help.

5.1.12 Error handling

This section provides information on handling errors and problems.

The following problems can occur:

- You cannot establish a connection.
- You cannot start an action.
- Errors occur when an action is started.
- The connection is interrupted.

If you cannot establish a connection, check the address entered, and also the availability and, if necessary, the system status of the ROBAR server's system components.

If execution of an action fails, the cause is specified in the parameter area of the dialog.

When you shut down the ROBAR server, the ROBAR-SV Manager is terminated together with all existing connections.

Search for the relevant topic in the online help if you require further information (see [section "Calling the online help" on page 116](#)).

If you still cannot solve the problem, contact Customer Support.

5.2 Controlling ROBAR operation using the ROBAR-SV Manager

On the ROBAR server you can control all ROBAR operations via the user-friendly user interface of the ROBAR-SV Manager.

5.2.1 Overview of tasks

This section describes the functions of the ROBAR-SV Manager on a task-related basis.



You can also obtain information on a function in the ROBAR-SV Manager's online help (see [section "Calling the online help" on page 116](#)).

As ROBAR administrator all the functions are available to you. As ROBAR operator selected functions are available to you which are listed in the task descriptions.

The table on the next page shows the following:

- the task
- the call of the associated range of functions in the ROBAR-SV Manager
- the page which contains the task description

Task	Call in the ROBAR-SV Manager	Page
Displaying information on ROBAR-SV instances	<i>Instances</i> menu, <i>Overview</i> tab	122
Creating and deleting ROBAR-SV instances	<i>Instances</i> menu, <i>Overview</i> tab	122
– Uploading a configuration file	Button <i>Uploading a configuration file</i>	123
– Creating a new instance	Button <i>Create new instance</i>	123
– Displaying a configuration file	<i>Display</i> action icon	123
– Deleting an instance	<i>Delete</i> action icon	124

Task	Call in the ROBAR-SV Manager	Page
Operating a ROBAR-SV instance	<i>Instances</i> menu, <i><name></i> instance <i>Operation</i> tab	125
– Starting or stopping an instance	<i>Instance <name></i> area, <i>Start</i> or <i>Stop</i> action icon	126
– Displaying, editing, downloading, uploading or checking a configuration file	<i>Instance <name></i> area, <i>Show</i> , <i>Edit</i> , <i>Download</i> , <i>Upload</i> or <i>Check</i> action icon	126
– Enabling and disabling automatic restart	<i>Automatic restart</i> area <i>Edit</i> action icon	127
– Manual entry of archive system commands	<i>Manual commands ...</i> area, Button <i>Send message to library</i>	128
– Displaying, editing, downloading or uploading ROBAR rule files	<i>ROBAR rule file handling ...</i> area <i>Display</i> , <i>Edit</i> , <i>Download</i> or <i>Upload</i> action icon	128
– Checking or checking and activating ROBAR rule files	<i>ROBAR rule file handling ...</i> area <i>Check only</i> , <i>Check & Publish</i> button	128
– Calling the <code>robar</code> menu program	<i>Instance Management</i> area, <i>Open</i> button	130
Displaying the status of the BS2000 systems and of the archive system of a ROBAR-SV instance	<i>Instances</i> menu, <i>BS2000 hosts & Library</i> tab	131
– Displaying VSN number ranges	<i>Archive number ranges</i> area	132
Displaying information on messages and devices of a ROBAR-SV instance	<i>Instances</i> menu, <i>Messages & Devices</i> tab	133
Editing logging files of ROBAR-SV instances	<i>Instances</i> menu, <i>Logging files</i> tab	134
– Displaying, downloading or removing a logging file	<i>Show</i> , <i>Download</i> or <i>Delete</i> action icon	135

Task	Call in the ROBAR-SV Manager	Page
Managing diagnostic information of the ROBAR-SV instances	<i>Instances</i> menu, <i>Diagnostics</i> tab	136
– Collecting current diagnostic data	<i>Diagnostic data area</i> , <i>Collect diagnostic data</i> button	137
– Download or delete diagnostic data	<i>Diagnostic data area</i> , <i>Download</i> or <i>Delete</i> action icon	137
– Displaying error counters	Area <i>Device and volume error counters</i>	138
– Displaying or resetting error information for devices and volumes	Area <i>Device and volume error counters</i> , <i>Show</i> or <i>Reset</i> action icon	138
– Outputting ROBAR statistics	<i>ROBAR statistics area</i> , <i>Compile statistics</i> button	138
Displaying information on the users of ROBAR-SV	<i>Management > Authorizations</i> menu, <i>Accounts</i> tab	139
Creating and managing SSL certificates. This topic is described only in the online help.	<i>Management > Authorizations</i> menu, <i>Certificates</i> tab	
Displaying information on the ROBAR server	Menu <i>Management ></i> <i>System overview</i>	139
Managing global configuration of the ROBAR server	Menu <i>Management > Configuration</i> , <i>Global configuration</i> tab	140
– Displaying, editing, downloading, uploading or resetting a global configuration file	<i>Global configuration file area</i> , <i>Display</i> , <i>Edit</i> , <i>Download</i> , <i>Upload</i> or <i>Reset</i> action icon	141
– Backing up, uploading, resetting, downloading, or deleting ROBAR configuration files	Area <i>Backup of configuration files</i> , <i>Execute backup</i> or <i>Upload backup</i> button <i>Reset</i> , <i>Download</i> , or <i>Delete</i> action icon	142
– Setting the automatic update	<i>Personal settings area</i> , <i>Edit</i> action icon	143
– Setting the session timeout value	<i>Personal security settings</i> , <i>Edit</i> action icon	143

Task	Call in the ROBAR-SV Manager	Page
Managing the partner configuration (CMX) of the ROBAR server	<i>Menu Management > Configuration</i>	144
– Add a new partner	<i>CMX configuration tab Partners list area, Add new partner button</i>	145
– Editing or removing partner data	<i>Partners list area, Delete or Change action icon</i>	145
– Add a new local name	<i>Local names list area, Add new local name button</i>	145
– Editing or removing a local name	<i>Local names list area, Delete or Edit action icon</i>	146
Creating and managing links to external devices and websites	<i>External links menu</i>	147
– Adding a link	<i>Add new external link button</i>	147
– Changing or deleting a link	<i>Change or Delete action icon</i>	147

5.2.2 Displaying information on ROBAR-SV instances

Role: ROBAR administrator, ROBAR operator

- Select the *Instances* menu, *Overview* tab.

The overview window of the ROBAR-SV Manager opens. In the tree structure and in the work area it displays the ROBAR-SV instances which are known on the ROBAR server, arranged according to ABBA and SCSI interface.



The overview window opens automatically after a login.

The screenshot shows the ROBAR-SV Manager interface. The left sidebar contains a tree view of instances, with 'ABBA' selected. The main area displays the 'Overview' tab with a table of instances. The table has columns for Name, Interface, Connection, Instance status, Connection status, and Action. The instances are listed as follows:

Name	Interface	Connection	Instance status	Connection status	Action
sci_kauzu_conf	ABBA	172.17.36.126,9059	RUNNING		
sci_kauzu_s	ABBA	172.17.36.126,9058	RUNNING		
test1	ABBA	fd11 fd52 4f34 c5b0 219 99ff fe83 a5f6,9057	STOPPED		
sci_meiseu_s	ABBA	172.17.37.75,9059	STOPPED		
sci_meiseu_conf	ABBA	172.17.37.75,9058	STOPPED		
sci_kauzu_s	ABBA	172.17.36.126,9059	STOPPED		
sci_meiseu_s	ABBA	172.17.37.75,9058	DEFINED		
cs_eule_conf	ABBA	172.17.36.123,9058	DEFINED		
sci_i15_conf	ABBA	172.17.35.57,3000	DEFINED		
cs_star_C4L4	ABBA	172.17.36.133,9059	DEFINED		
cs_kiwi_conf	ABBA	172.17.30.129,9059	DEFINED		
test01	ABBA	-	DEFINED		
cs_uhu_conf	ABBA	172.17.36.137,9058	DEFINED		
cs_star_conf	ABBA	172.17.36.133,9058	DEFINED		
test05	ABBA	-	DEFINED		

Number of instances: 34

The information is described in the online help.

The *Upload configuration file* and *Create new instance* buttons and the *Delete* and *Show* action icons are not always available, see the table on [page 149](#).

- Select *Instances* > *ABBA* if you only want to see information on the instances with an ABBA interface.
- Select *Instances* > *SCSI* if you only want to see information on the instances with a SCSI interface.

5.2.3 Creating and deleting ROBAR-SV instances

You can perform the following tasks:

- Upload a configuration file
- Create a new ROBAR-SV instance
- Display the configuration file of a ROBAR-SV instance
- Delete a ROBAR-SV instance.

Role: ROBAR administrator

- ▶ Select the *Instances* menu, *Overview* tab, see [page 122](#).

5.2.3.1 Uploading a configuration file

If you wish to create a new ROBAR-SV instance on the basis of an existing configuration file, you must upload this configuration file, i.e. integrate it into the ROBAR system.

- ▶ In the overview window click the *Upload configuration file* button.
- ▶ Make the necessary entries in the *Upload configuration file* dialog box. The entries are described in the online help.

After the configuration file has been successfully uploaded, you can use it to configure a new ROBAR-SV instance, see above.

5.2.3.2 Creating a new instance

- ▶ In the overview window click the *Create new instance* button.

The wizard for configuring a new instance is started. This will guide you through the task step by step.

- ▶ Make the necessary entries in the *Create new instance* dialog steps, see [page 111](#). The entries are described in the online help.

After it has been created successfully, the new instance has the requisite interface-specific configuration file. This has already been adjusted to the current environment.

5.2.3.3 Displaying an instance's configuration file

- ▶ Click the *Show* action icon of the required instance in the *Action* column.

A dialog window opens which displays the name and content of the instance's interface-specific configuration file. You can scroll the display up and down, and set the size of the dialog window.

5.2.3.4 Deleting an instance

Only instances which are not in the RUNNING status can be deleted.

- ▶ Click the *Delete* action icon of the required instance in the *Action* column.

Following a confirmation dialog this action removes the ROBAR-SV instance from ongoing operations. Its files, including the configuration file, will be deleted.

5.2.4 Operating a ROBAR-SV instance

You can perform the following tasks:

- Start, restart, reset, or stop ROBAR-SV instances
 - Edit, download, upload, or check the configuration file of the ROBAR-SV instance
 - Control the automatic restart of ROBAR-SV instances
 - Enter archive system commands for the ROBAR-SV instance manually
 - Edit the ROBAR rule files of the ROBAR-SV instance
 - Call the `robar` menu program for the selected instance
- ▶ Select the *Instances* menu, see [page 122](#).
 - ▶ Select *Instances > ABBA* or *SCSI > "Name of the instance"* in the primary navigation or click the instance name in the work area.
 - ▶ The *Operation* tab is shown.

The screenshot shows the ROBAR-SV Manager interface. The top navigation bar includes 'ROBAR-SV Manager', 'ROBAR Server (abgrobbx)', 'manuals', 'Log out', 'FUJITSU', 'English [Wechseln zu Deutsch]', and 'Help'. The left sidebar shows a tree view of instances under 'ROBAR-SV', with 'sci_i25_conf' selected under the 'SCSI' category. The main content area is titled 'Operation' and shows details for instance 'sci_i25_conf'. It includes a table with columns 'Name', 'Instance status', 'Operation', and 'Configuration'. Below this are sections for 'Automatic restart' (with a table for settings), 'Manual commands' (with a 'Send message to library' button), 'ROBAR rule file handling', and 'Instance management' (with a terminal link).

Name	Instance status	Operation	Configuration
sci_i25_conf	RUNNING	[Start] [Restart] [Stop]	[Edit] [Download] [Upload]

Setting	Value	Action
Automatic restart	NO	[Edit]

Which action icons are available in the *Operation*, *Configuration*, and *Action* columns depends on the status of the instance and the role of the ROBAR user. The information is described in the online help.

5.2.4.1 Starting, restarting, resetting, or stopping an instance

Restarting is only possible for instances in the RUNNING status. Restarting an instance is the same as stopping an instance and then starting it.

Resetting is only possible for instances in the STOPPED status. When an instance is reset, all its runtime files are deleted (see [page 205](#)). The instance's configuration file is retained. The instance is placed in the DEFINED status.

Role: ROBAR administrator, ROBAR operator (starting and restarting only)

- ▶ Click one of the action icons *Start*, *Restart*, *Reset*, or *Stop*.



When an instance is started or restarted, the following trace files are deleted if they are older than the number of days defined in the global configuration file of ROBAR-SV using the `max_trace_file_age` parameter (see [page 211](#)):

- CMX trace files (`inotrc.*`)
 - Trace files of the ROBAR-SV instance
 - Backed-up trace files (see `RECOVER_DISK_FULL` script, [page 54](#))
- ▶ Confirm your action in the subsequent dialog box.

A dialog window opens which displays the execution of the action selection.

5.2.4.2 Editing the instance's configuration file

Role: ROBAR administrator

- ▶ Click the *Edit* action icon.

A dialog window opens which displays the name and content of the instance's interface-specific configuration file. You can scroll the display up and down, set the size of the dialog window, and edit the content with the ROBAR editor. The display formats of the editor and its functions are described in the online help.

- ▶ In the dialog box click the *Save* button to save the configuration file.

The configuration file is checked for errors. If the configuration file is errorfree, an instance in the DEFINED status is assigned the new status STOPPED, otherwise it remains in the DEFINED status.

5.2.4.3 Downloading the instance's configuration file

Role: ROBAR administrator

- ▶ Click the *Download* action icon.

The configuration file is downloaded to a directory of your choice on your PC. You can now edit it on your PC.

5.2.4.4 Uploading the instance's configuration file

Role: ROBAR administrator

- ▶ Click the *Upload* action icon.

In the dialog box which is then displayed you enter the name of the file on your PC which you wish to upload. You can select the file in your PC's file tree using the *Search* button.

- ▶ In the dialog box click the *Upload* button to replace the instance's "old" configuration file.

The "new" configuration file is checked for errors. If the configuration file is errorfree, an instance in the DEFINED status is assigned the new status STOPPED, otherwise it remains in the DEFINED status.

5.2.4.5 Checking the configuration file

Role: ROBAR administrator

- ▶ Click the *Check* action icon.

The current configuration file is checked. The result is displayed in a dialog.

5.2.4.6 Enabling and disabling automatic restart

Role: ROBAR administrator, ROBAR operator

This option causes a ROBAR-SV instance to be restarted automatically following an orderly program termination initiated by the user or by program events. See also [page 46](#).

- ▶ In the *Automatic restart* area, click the *Change* action icon.

A dialog window opens in which you can enable or disable automatic restart.

5.2.4.7 Manual entry of archive system commands

Opens a dialog box in which you can enter archive system commands and the BS2000 command /UNLOAD-TAPE.

This function corresponds to the **MANUAL** menu of the `robar` menu program.

Role: ROBAR administrator

- ▶ In the *Manual Commands* area click the *Send message to library* button.

The *Send message to library* button is enabled only when the ROBAR-SV instance is in the **RUNNING** status.

- ▶ Make the necessary entries in the *Manual Commands* dialog box. The entries are described in the online help.



The command is executed asynchronously at a suitable time in the ROBAR processes. This can take up to 10 minutes.

5.2.4.8 Editing the ROBAR rule files

Role: ROBAR administrator

- ▶ Expand the *ROBAR rule file handling* area

▼ ROBAR rule file handling

Check only

Check & Publish

Filename	Description	State	Action
roboter_cmds	Archive system commands together with their operands		
message_file	Messages requiring a response from the ROBAR system		
message_resp.e	BS2000 actions which are initiated by ROBAR (English)		
message_resp.d	BS2000 actions which are initiated by ROBAR (German)		
error_defines	File with the measures to be taken if serious errors occur		
message_xref	Actions triggered by events specified in the message_file		
TYPE-1/message_xref	message_xref for device type TYPE-1		

Action list for a ROBAR message: MF000 ▼ Show

When expanded, this area offers an overview of the ROBAR rule files of the ROBAR-SV instance. You can perform the following tasks:

- Checking and publishing ROBAR rule files

The *Check only* and *Check & Publish* buttons are enabled only when ROBAR rule files which have been changed but not activated exist for the instance.

- Displaying, editing, downloading, uploading, and resetting ROBAR rule files
 - ▶ Click the *Show* action icon of the required ROBAR rule file in the *Action* column.
A dialog window opens which displays the name and content of the instance's ROBAR rule file. You can scroll the display up and down, and set the size of the dialog window. The display formats are described in the online help.
 - ▶ Click the *Edit* action icon of the required logging file in the *Action* column.
A dialog window opens which displays the name and content of the ROBAR rule file. You can scroll the display up and down, set the size of the dialog window, and edit the content with the ROBAR editor. The display formats of the editor and its functions are described in the online help.
 - ▶ Click the *Download* action icon of the required ROBAR rule file in the *Action* column.
The ROBAR rule file is downloaded to a directory of your choice on your PC. You can now edit it on your PC.
 - ▶ Click the *Upload* action icon of the required ROBAR rule file in the *Action* column.
In the dialog box which is then displayed you enter the name of the file on your PC which you wish to upload. You can select the file in your PC's file tree using the *Search* button.
 - ▶ Click the *Reset* action icon of the required ROBAR rule file in the *Action* column.
The ROBAR rule file is reset to the status it had when delivered.
- In the *Action list for a ROBAR message* line you can use the *Show* action icon to have information displayed about a selected console message and the actions defined there. This function corresponds to the `SHOW` parameter in the `DEFINES` menu of the `robar` menu program.

5.2.4.9 Calling the “robar” menu program for the selected instance

Role: ROBAR administrator, ROBAR operator

- ▶ In the *Instance Management* area click the *Open* button.

The main window of the `robar` menu program appears for the interface of the instance (in the example: SCSI), but without the `INSTANCES` menu. The selected instance is preset for execution of the menu program and cannot be changed.

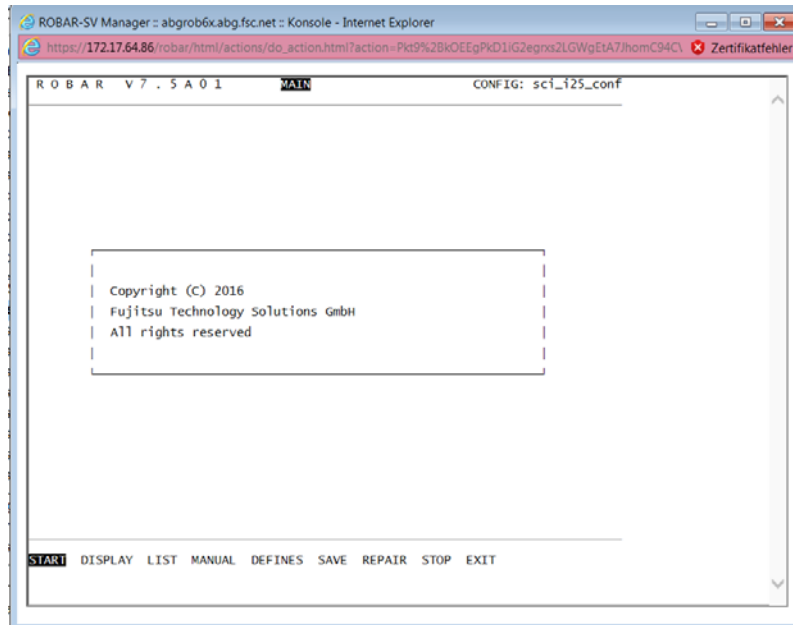

- ▶ Execute the required actions in the `robar` menu program, see [section “Operation using the “robar” menu program” on page 148](#).
- ▶ Select the `EXIT` menu to close the `robar` menu program and the window.

5.2.5 Displaying the status of the BS2000 systems and of the archive system

You can display an overview of the status of the connected BS2000 systems and the operated archive system of a ROBAR-SV instance. You can also have the range of VSNs for the ROBAR-SV instances displayed.

This tab is displayed only when the ROBAR-SV instance is not in the DEFINED status.

Role: ROBAR administrator, ROBAR operator

- ▶ Select the *Instances* menu, see [page 122](#).
- ▶ Select *Instances* > *ABBA* or *SCSI* > “Name of the instance”.
- ▶ Click the *BS2000 hosts & Library* tab.

The screenshot shows the ROBAR-SV Manager interface for a ROBAR Server (abgrobbx). The left sidebar shows a tree view of instances, with 'sci_i25_conf' selected under the SCSI category. The main content area is divided into several sections:

- Library information:** A table showing details for the SCSI interface.

ROBAR interface	SCSI
Connection	3600308c001415800
Location	ROBI25
Archive type	scsi-1
Information	This is a test for the sci_i25_conf file
- Status of instance sci_i25_conf:** A diagram showing the instance 'instance sci_i25_conf' in a 'running' state, connected to 'BS2000 hosts' (1 online, 3 offline) and a 'Library' (AMU1 and Robot1, both online).
- BS2000 host status (Notification host: 411):** A table listing host details.

Host alias	IP address	FQDN	DCAM application	MAREN host	Connection status
S43	172.17.66.170	abggn403.abg.fsc.net	ROBAR25K	No	Offline
S2B	172.17.67.160	abgse21b.abg.fsc.net	ROBAR25K	No	Offline
411	172.17.65.154	abgse411.abg.fsc.net	ROBAR25K	No	Online
401	172.17.65.144	abgse401.abg.fsc.net	ROBAR25K	Yes	Offline
- Archive number ranges:** A section for displaying VSN ranges.

The information is displayed in multiple areas. The areas are described in the online help.

5.2.5.1 Displaying the Archive number ranges

This function corresponds to part of the LIST menu of the `robar` menu program.

Role: ROBAR administrator, ROBAR operator

- ▶ Expand the *Archive number ranges* area.

Host alias	VSN
SE1MON	BAB000-BAB999
SE1VM2	BAB000-BAB999
SE1VM2	BAB000-BAB999

Number of hosts: 3

Primary volumes
BAB000-BAB999

Additional volumes

When expanded, this area offers overviews of the following archive number ranges:

- The server-related VSN number ranges
- The global VSN number ranges (primary volumes)
- The server-related VSN number ranges (additional volumes) of the ROBAR-SV instance

Cleaning cartridges are not shown.

5.2.6 Displaying information on messages and devices

You can display the last 100 messages in the ROBAR system and a device and volume overview of a ROBAR-SV instance. This tab is displayed only when the ROBAR-SV instance is not in the DEFINED status.

Role: ROBAR administrator, ROBAR operator

- ▶ Select the *Instances* menu, see [page 122](#).
- ▶ Select *Instances* > *ABBA* or *SCSI* > “*Name of the instance*”.
- ▶ Click the *Messages & Devices* tab.

The screenshot shows the ROBAR-SV Manager interface. The left sidebar lists instances under 'ABBA' and 'SCSI'. The 'Messages & Devices' tab is active, showing a table of messages for instance 'sci_kauzu_conf' and a table of devices and media.

Messages for instance sci_kauzu_conf

Timestamp	Direction	Message
2016-09-20 11:54:52	<-MAN	H 1 ROBAR <ASYN.ACOM,,###,1,,vvvvv,,aaaaaaaa.bbbbbbbbu
2016-09-20 11:54:53	->ROB	H 1 ROBAR <ASYN.ACOM,,1,,...,20i15453>
2016-09-20 12:14:53	<-MAN	H 1 ROBAR <ASYN.ACOM,,###,1,,vvvvv,,aaaaaaaa.bbbbbbbbu
2016-09-20 12:14:53	->ROB	H 1 ROBAR <ASYN.ACOM,,1,,...,20i121453>
2016-09-20 12:34:53	<-MAN	H 1 ROBAR <ASYN.ACOM,,###,1,,vvvvv,,aaaaaaaa.bbbbbbbbu
2016-09-20 12:34:53	->ROB	H 1 ROBAR <ASYN.ACOM,,1,,...,20i123453>
2016-09-20 12:54:53	<-MAN	H 1 ROBAR <ASYN.ACOM,,###,1,,vvvvv,,aaaaaaaa.bbbbbbbbu
2016-09-20 12:54:53	->ROB	H 1 ROBAR <ASYN.ACOM,,1,,...,20i125453>

Number of messages: 300

Devices & Media

Device name (MN)	Device type	BS2000 host	VSN
A020	TAPE-U4	411	
A021	TAPE-U4	411	
A022	TAPE-U4	411	
A023	TAPE-U4	411	
A024	TAPE-U4	411	
A025	TAPE-U4	411	
A026	TAPE-U4	411	
A027	TAPE-U4	411	

Number of devices: 8

The information is displayed in the *Messages for instance* <name_of_instance> and *Devices & Media* areas. The areas are described in the online help.

5.2.7 Editing logging files of ROBAR-SV instances

You can view, download or delete the logging files of ROBAR-SV instances. This tab is displayed only when the ROBAR-SV instance is not in the DEFINED status.

Role: ROBAR administrator, ROBAR operator

- ▶ Select the *Instances* menu, see [page 122](#).
- ▶ Select *Instances* > *ABBA* or *SCSI* > “*Name of the instance*”.
- ▶ Click the *Logging Files* tab.

The screenshot shows the ROBAR-SV Manager interface. The left sidebar displays a tree view of instances under 'ABBA' and 'SCSI'. The 'sci_kauzu_conf' instance is selected. The main area shows two tabs for logging files:

Logging files for instance sci_kauzu_conf (/cmx)

Number	Filename	Date from	Date to	Action
1	robar.mess	2016-09-08 14:46	2016-09-20 12:54	[Download] [Delete]
2	robar.resp	2016-09-08 14:46	2016-09-20 10:54	[Download] [Delete]
3	robar.mess.160908144637	2016-09-08 09:10	2016-09-08 11:17	[Download] [Delete] [Refresh]
4	robar.resp.160908144637	2016-09-08 09:10	2016-09-08 11:08	[Download] [Delete] [Refresh]

Number of files: 4

Logging files for instance sci_kauzu_conf (/trace)

Number	Filename	Action
1	nbs2.trace	[Download] [Delete]
2	netgate_in.trace	[Download] [Delete]
3	netgate_out.trace	[Download] [Delete]
4	robar.trace	[Download] [Delete]
5	vbs2.trace	[Download] [Delete]
6	nbs2.trace.160908144644	[Download] [Delete] [Refresh]
7	vbs2.trace.160908144644	[Download] [Delete] [Refresh]
8	netgate_in.trace.160908144637	[Download] [Delete] [Refresh]
9	netgate_out.trace.160908144637	[Download] [Delete] [Refresh]
10	robar.trace.160908144637	[Download] [Delete] [Refresh]

Number of files: 10

Depending on its directory (*/cmx* or */trace*), the information is displayed in different areas. The files in the areas are sorted according to their start date - from youngest to oldest. The areas are described in the online help.

5.2.7.1 Displaying the instance's logging file

- ▶ Click the *Show* action icon of the required logging file in the *Action* column.

A dialog window opens which shows you the name and content of the instance's logging file. Up to 1,000 rows are displayed. You can scroll the display up and down, and set the size of the dialog window. The display formats are described in the online help.

5.2.7.2 Downloading the instance's logging file

- ▶ Click the *Download* action icon of the required logging file in the *Action* column.

The logging file is downloaded to a directory of your choice on your PC. You can now save it or work with it on your PC, e.g. search for errors.

5.2.7.3 Removing the instance's logging file

- ▶ Click the *Delete* action icon of the required logging file in the *Action* column.

The logging file will be removed on your PC.

5.2.8 Diagnostic information on the ROBAR-SV instance

You can perform the following tasks:

- Collecting current diagnostic data
 - Download or delete diagnostic data
 - Display error counter limits (ROBAR administrator only)
 - Edit error information for devices and volumes (ROBAR administrator only)
 - Outputting ROBAR statistics
- ▶ Select the *Instances* menu, see [page 122](#).
- ▶ Select *Instances > ABBA* or *SCSI > "Name of the instance"*.
- ▶ Click the *Diagnostics* tab.

The screenshot displays the ROBAR-SV Manager web interface. The top navigation bar includes 'ROBAR-SV Manager', 'ROBAR Server (abgrobf6x)', 'manuals', 'Log out', 'FUJITSU', and 'English [Wechseln zu Deutsch] Help'. The main content area is titled 'ROBAR-SV' and features a sidebar with a tree view of instances. The 'Instances' menu is expanded, showing 'ABBA' and 'SCSI' categories. Under 'SCSI', the 'sci_i25_conf' instance is selected. The main panel shows the 'Diagnostics' tab for this instance, with the path 'ROBAR_SAVE_DIR = /var/opt/fujitsu/robar'. It contains three sections: 'Diagnostic data' with a 'Collect diagnostic data' button and a table listing a file 'SCSI_sci_i25_conf_2016-09-06_14-13-23_diag.tar.gz'; 'Device and volume error counters' showing limits of 100 for device and volume errors, and a table for 'Defective drives / media' with an error counter of 0; and 'ROBAR statistics' with a 'Compile statistics' button.

The information is displayed in different areas. The areas are described in the online help.

5.2.8.1 Collecting current diagnostic data

Role: ROBAR administrator, ROBAR operator

As an alternative to creating diagnostic data with scripts, you can also collect the diagnostic documentation required in this menu.

This function corresponds to the `SAVE` menu of the `robar` menu program.

See also the [section “Diagnostic documentation for the ROBAR server” on page 328](#).

The tasks are described in the online help.

- ▶ In the *Diagnostic data* area click the *Collect diagnostic data* button.

A dialog window opens in which you can confirm or cancel collection of the diagnostic data. After you have collected the diagnostic data, you can download the file containing the diagnostic data directly in the dialog and delete it on the ROBAR-SV server.

Diagnostic data is by default saved in the `/var/opt/fujitsu/robar` directory. You can change the directory using the configuration parameter `ROBAR_SAVE_DIR` (see [page 211](#)).

5.2.8.2 Editing diagnostic data

Role: ROBAR administrator, ROBAR operator

Downloading the file containing the diagnostic data

- ▶ Click the *Download* action icon in the *Action* column.

A dialog window opens in which you can download the file containing the diagnostic data to your PC.

Deleting diagnostic data

- ▶ Click the *Delete* action icon in the *Action* column.

The file containing the diagnostic data is deleted.

5.2.8.3 Displaying device and volume error

Role: ROBAR administrator

This area informs you about the error counters `device_error_limit` and `volume_error_limit` (see [page 215](#)) which are set in the interface-specific configuration file of ROBAR-SV for a ROBAR-SV instance.

The faulty devices and volumes are displayed with error counters in a table.

This function corresponds to the `REPAIR` menu of the `robar` menu program.

Details on the error situations are provided in the [section “Device and volume error counters” on page 318](#).

5.2.8.4 Editing error information for devices and volumes

Role: ROBAR administrator

Displaying error information

- ▶ Click the *Show* action icon in the *Action* column.
A dialog window opens which displays the error information.

Resetting error information

- ▶ Click the *Reset* action icon in the *Action* column.
The error information and the error counter for the device / volume will be reset.

5.2.8.5 Outputting ROBAR statistics

Role: ROBAR administrator, ROBAR operator

In this area you can evaluate trace files for a specified period, i.e. display statistics. The statistics and their report lists are described on [page 341](#).

This function corresponds to the `EVAL` function in the `LIST` menu of the `robar` menu program.

- ▶ In the *ROBAR Statistics* area click the *Compile statistics* button.
A dialog window opens in which you can specify the trace files, the evaluation period, and the type of statistics. After the statistics have been compiled, they are displayed in a dialog box. You can download the statistics.

5.2.9 Displaying information on the users of ROBAR-SV

You can have an overview of the users of ROBAR-SV displayed on the ROBAR server.

Role: ROBAR administrator

- ▶ Select the *Management > Authorizations* menu, *Accounts* tab.

Type	Account	Role	Name	Comment
All	Filter	All	Filter	Filter
🏠	manuals	ROBAR Administrator		
🏠	ro65opr	ROBAR Operator	Operator	
🏠	ro65scsi	ROBAR Administrator	ro65scsi	
🏠	robar	ROBAR Operator		
🏠	wwwrun	ROBAR Administrator	WWW daemon apache	

Number of accounts: 5

The information is described in the online help.

5.2.10 Displaying information on the ROBAR server

You can have an overview of the system properties of the ROBAR server displayed.

Role: ROBAR administrator, ROBAR operator

- ▶ Select the *Management > System overview* menu.

Property	Value
ROBAR-SV version	V07.5A03
Hostname	abgro6bx.abg.fsc.net
Operating system	SUSE Linux Enterprise Server 11 (x86_64) PATCHLEVEL = 4
Kernel version	3.0.101-63-default
System start	2016-09-06 13:22:10

The information is described in the online help.

5.2.11 Managing global configuration of the ROBAR server

You can perform the following tasks:

- Edit the global configuration file of the ROBAR server (ROBAR administrator only)
- Backing up and restoring ROBAR configuration files (ROBAR administrator only)
- Setting the automatic update on a user-specific basis
- Setting the session timeout value on a user-specific basis

► Select the *Management > Configuration* menu, *Global configuration* tab.

The screenshot displays the ROBAR-SV Manager web interface. The top navigation bar includes 'ROBAR-SV Manager', 'ROBAR Server (abgrobb6x)', 'manuals', 'Log out', 'FUJITSU', 'English [Wechseln zu Deutsch]', and 'Help'. The left sidebar shows a menu with 'ROBAR-SV' and 'Configuration' selected. The main content area is titled 'Global configuration' and 'CMX configuration'. It contains four sections: 'Global configuration file' with a table showing the filename '/etc/robar.conf' and an action icon; 'Backup of configuration files' with 'Execute backup' and 'Upload backup' buttons, and a table showing the archive name 'abgrobb6x_ROBAR_conf_2016-05-19_10-50-05_backup.tar.gz' and an action icon; 'Personal settings' with a table showing 'Automatic actualization' set to 'On (10 s)'; and 'Personal security settings' with a table showing 'Session timeout' set to 'On (20 min)'.

The information is displayed in different areas. The areas are described in the online help.

5.2.11.1 Editing the global configuration file of the ROBAR server

Role: ROBAR administrator

The global configuration file `/etc/robar.conf` of ROBAR-SV contains the configuration parameters which are important for executing all ROBAR-SV instances, see [section “Global configuration file for ROBAR-SV” on page 210](#). It is created when ROBAR-SV is installed and is provided with the default values.

You can edit the global configuration file using the functions below. The tasks are described in the online help.

Displaying a global configuration file

- ▶ Click the *Show* action icon in the *Action* column.

A dialog window opens in which the global configuration file is displayed. You can scroll the display up and down, and set the size of the dialog window.

Editing a global configuration file

- ▶ Click the *Edit* action icon in the *Action* column.

A dialog window opens which displays the name and content of the global configuration file which is to be modified. You can scroll the display up and down, set the size of the dialog window, and edit the content with the ROBAR editor. The display formats of the editor and its functions are described in the online help.

Downloading the global configuration file

- ▶ Click the *Download* action icon in the *Action* column.

A dialog window opens in which you can download the global configuration file to your PC.

Uploading a configuration file

- ▶ Click the *Upload* action icon in the *Action* column.

A dialog window opens in which you can upload a global configuration file from your PC to the ROBAR system. The file loaded overwrites the currently valid global configuration file and will become valid the next time you start ROBAR-SV.

Resetting a global configuration file

- ▶ Click the *Reset* action icon in the *Action* column.

The global configuration file is reset to the status it had when delivered.

5.2.11.2 Backing up and restoring ROBAR configuration files

Role: ROBAR administrator

The ROBAR configuration files are backed up once only. Any backup archive which already exists is deleted by subsequent backups or when a backup archive is uploaded.

The following functions enable you to back up and restore the ROBAR configuration files and to edit the backup archive.

The tasks are described in the online help.

Backing up ROBAR configuration files

- ▶ In the *Backup of configuration files* area, click the *Execute backup* button.

A dialog window opens in which you can confirm or cancel backup of the ROBAR configuration files.

The ROBAR configuration files are backed up as a `tar` archive in the `/var/opt/fujitsu/robar/config_backup` directory.

If a backup has already been created, the archive name (`<server name>_ROBAR_conf_<yyyy-mm-dd_hh:mm:ss>.backup.tar.gz`) of the `tar` archive is displayed in the *Configuration data backup* area.

Uploading a backup archive

- ▶ Click the *Upload backup* button in the overview window.

A dialog window opens in which you can upload a backup archive from your PC to the ROBAR system.

The uploaded backup archive overwrites any backup archive which already exists and can be used to restore the ROBAR configuration files.

Resetting ROBAR configuration files

- ▶ Click the *Reset* action icon in the *Action* column.

The ROBAR configuration files are reset to the backed-up status.

Restoring the ROBAR configuration files has no immediate repercussions on ROBAR operation.

Downloading a backup archive

- ▶ Click the *Download* action icon in the *Action* column.

A dialog window opens in which you can download the backup archive to your PC.

Deleting a backup archive

- ▶ Click the *Delete* action icon in the *Action* column.

The backup archive is deleted.

5.2.11.3 Setting the automatic update on a user-specific basis

Role: ROBAR administrator, ROBAR operator

The automatic update ensures that the data displayed in the main window is up to date. All the data displayed is updated in each update cycle.

See [section “Automatic update \(standalone variant\)” on page 108](#).

You can edit the update cycle.

- ▶ In the *Personal settings* area click the *Change* action icon.

A dialog window opens in which you can enable or disable the automatic update and define a time period in seconds.

5.2.11.4 Setting the session timeout value on a user-specific basis

Role: ROBAR administrator, ROBAR operator

The session timeout value defines when a user's session times out due to inactivity, i.e. when the ROBAR-SV Manager registers no user activity in this period. See [section “Session timeout \(standalone variant\)” on page 107](#).

You can edit the session timeout value.

- ▶ In the *Personal security settings* area click the *Change* action icon.

A dialog window opens in which you can enable or disable the session timeout value and define a period of time in minutes.

5.2.12 Managing the partner configuration (CMX) of the ROBAR server

ROBAR-SV communicates with ROBAR-CL via CMX on the various BS2000 systems (partners), see [section “Generation of names for CMX” on page 238](#).

You can perform the following tasks:

- Add a new partner
- Deleting or changing partner data
- Add a new local name
- Deleting or changing a local name

Role: ROBAR administrator

- ▶ Select the *Management > Authorizations* menu, *CMX configuration* tab.



The *Management > Configuration* menu is only visible to the ROBAR administrator.

The screenshot shows the ROBAR-SV Manager interface. The top navigation bar includes 'ROBAR-SV Manager', 'ROBAR Server (abgro6bx)', and user options like 'manuals', 'Log out', 'FUJITSU', 'English [Wechseln zu Deutsch]', and 'Help'. The left sidebar shows a tree view with 'ROBAR-SV' expanded, containing 'Instances' (ABBA, SCSI), 'Management' (Authorizations, System overview, Configuration), and 'External links' (Scalans6000, Scalans500, Documentation). The main content area is titled 'Global configuration' and 'CMX configuration'. It features a 'Partners list' table with an 'Add new partner' button. The table has columns: Partner name, IP address, Port, T-selector, and Action. Below the table, it indicates 'Number of partners: 142'. At the bottom, there is a 'Local names list' section.

Partner name	IP address	Port	T-selector	Action
ABG21BME	172.17.67.168	102	CESTMEIS	[edit] [delete]
ABG21BMU	172.17.67.168	102	CESTMEIU	[edit] [delete]
ABG21CME	172.17.67.169	102	CESTMEIS	[edit] [delete]
ABG30153	172.17.64.112	102	ROBAR503	[edit] [delete]
ABG30155	172.17.64.112	102	ROBAR505	[edit] [delete]
ABG40125	172.17.65.144	102	ROBAR25K	[edit] [delete]
ABG411ME	172.17.65.154	102	CESTMEIS	[edit] [delete]
ABG411MU	172.17.65.154	102	CESTMEIU	[edit] [delete]
ABGS2B15	172.17.67.168	102	ROBAR15K	[edit] [delete]
ABGS2B25	172.17.67.168	102	ROBAR25K	[edit] [delete]
ABGS2B26	172.17.67.168	102	ROBAR26K	[edit] [delete]
ABGS2B55	172.17.67.168	102	ROBAR505	[edit] [delete]
ABGS2B56	172.17.67.168	102	ROBAR56K	[edit] [delete]
ABGS2BKA	172.17.67.168	102	CESTKAU	[edit] [delete]

The information is displayed in different areas. The areas are described in the online help.

5.2.12.1 Add a new partner

- ▶ In the *Partner list* area click the *Add new partner* button.
- ▶ Make the necessary entries in the subsequent *Add New CMX partner* dialog box. The entries are described in the online help. The entry is immediately valid for the new partner.



In ROBAR V7.5 and higher you can use the dialog box to define whether or not ROBAR is to automatically generate an associated local name. If the local name is generated automatically, it is the same as the name of the new partner. You then do not need to add a local name for the partner.

5.2.12.2 Deleting or changing partner data

- ▶ Click the *Delete* action icon in the *Action* column of the *Partners list*.
The partner will be removed following a confirmation dialog.
- ▶ Click the *Edit* action icon in the *Action* column of the *Partners list*.

A dialog window opens which displays the partner's configuration data which is to be changed. Editable fields are highlighted red when they contain no or incorrect entries.

5.2.12.3 Add a new local name

- ▶ In the *Local names list* area click the *Add new local name* button.
- ▶ Make the necessary entries in the subsequent *Add new local name* dialog box. The entries are described in the online help. The entry for the new local name is immediately valid.



If you have the local name generated automatically by ROBAR when the partner is added, you do not need to add a local name for the partner.

5.2.12.4 Deleting or changing a local name

- ▶ Click the *Delete* action icon in the *Action* column of the *Local names list*.

The local name will be removed following a confirmation dialog.

- ▶ Click the *Edit* action icon in the *Action* column of the *Local names list*.

A dialog window opens which displays the local name which is to be changed. The field is highlighted red when it contains no or incorrect entries.



Automatically generated local names cannot be removed or modified. They are removed automatically when the partner is removed. The action icons for automatically generated local names are gray.

5.2.13 Creating and managing links to external devices and websites

You can establish links to external devices and websites in the tree structure.

Role: ROBAR administrator (full functionality)
ROBAR operator (use only, no management)

- ▶ Select the *External links* menu.

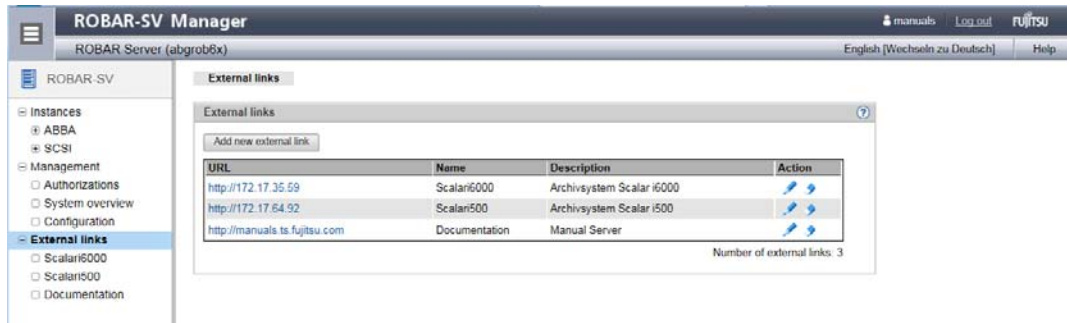

The information is described in the online help.

Adding a new link

- ▶ Click the *Add new external link* button.

A dialog window opens in which you can enter the name and description of the link. When the mask is completed correctly, a new link is created.

Changing a link

- ▶ Click the *Edit* action icon.

A dialog window opens which shows you the name and description of the link. You can edit the content.

Deleting a link

- ▶ Click the *Delete* action icon.

This action removes the link following a confirmation dialog box.

5.3 Operation using the “robar” menu program

With the `robar` menu program, as with the ROBAR-SV Manager, you can control all ROBAR operation.

For more in-depth functions the ROBAR-SV Manager also contains a call for the `robar` menu program for a ROBAR-SV instance which has already been selected, see [page 130](#).

Calling the menu program

Call the `robar` menu program in the Linux shell in accordance with the interface:

SCSI interface: `robar scsi` or `robar -s` or `robadmins` command

ABBA interface: `robar abba` or `robar -a` or `robadma` command

When the menu program is called for the first time, select the required ROBAR-SV instance in the `INSTANCES` menu. The other menus process this selected ROBAR-SV instance.

The ROBAR-SV instance selected in the `INSTANCES` menu in the previous menu program run continues to remain selected when the menu program is called again.

You can monitor ROBAR operation from different locations or terminals.

5.3.1 User groups and functional scope

The `robar` menu program offers a different range of functions when it is called depending on the caller’s group affiliation:

- The first ROBAR administrator (member of the `robaradm` and `robarsv` user groups) who calls the menu program is granted the complete and unrestricted range of functions (see [figure 9 on page 150](#)).
- Further ROBAR administrators (members of the `robaradm` and `robarsv` user groups) are also normally granted the full range of functions. However, when another ROBAR administrator has already selected an instance for editing in the `INSTANCES` menu (`SELECT` function), further ROBAR administrators (with the exception of the “first” ROBAR administrator) can only edit this instance with restrictions:
 - In the `INSTANCES` menu this instance is selected with the `SELECT` function, but a warning (RSV1434) is issued.
 - The `EDIT` and `DELETE` functions are then not available for this selected instance in the `INSTANCES` menu.
 - The `DEFINES`, `FREEPOOL` and `MANUAL` menus are then not available for this selected instance.

- ROBAR operators (member of the `robarsv` user group) are then offered a restricted functional scope.

Menu	“First” ROBAR administrator	Further ROBAR administrators	ROBAR operators
DEFINES	Available	Available ¹ / Not available ²	Not available
DISPLAY	Available	Available	Available
EXIT	Available	Available	Available
FREEPOOL	Available	Available ¹ / Not available ²	Not available
INSTANCES SELECT, START, STOP DELETE, EDIT	Available Available Available	Available Available Available ¹ / Not available ²	Available Available Not available
LIST	Available	Available	Available
MANUAL	Available	Available ¹ / Not available ²	Not available
REPAIR	Available	Available	Available
SAVE	Available	Available	Available
START	Available	Available	Available
STOP	Available	Available	Available

¹ When this ROBAR administrator is the first to have selected the instance as the first for editing

² When another ROBAR administrator has selected the instance concerned for editing

5.3.2 Screen layout

The first line is the ROBAR menu header, which gives you information on the ROBAR version, the selected ROBAR menu and the selected ROBAR-SV instance.

Lines 3 - 23 are reserved for screen output and ROBAR forms.

The last line displays program messages, error messages and the parameters provided for the selected menu.

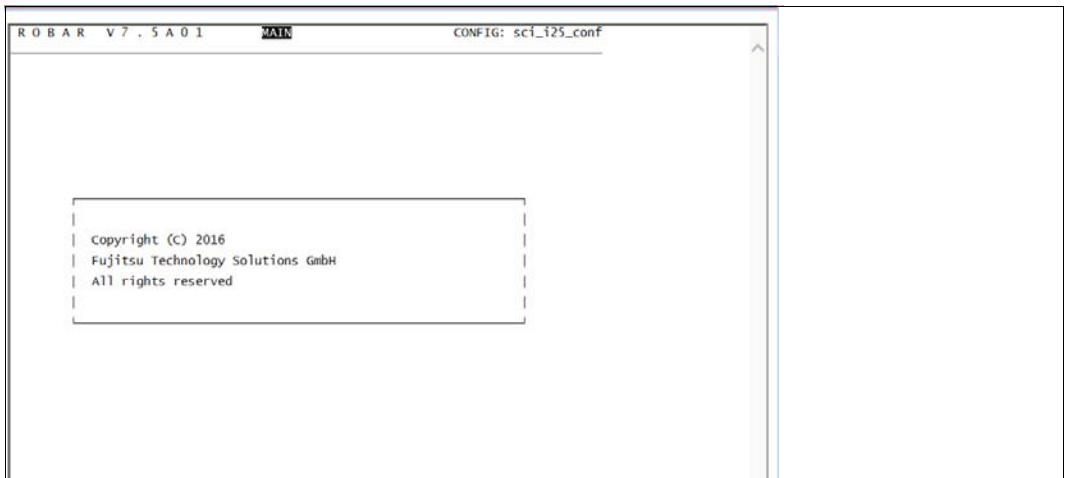

Figure 9: Main menu

Selecting menus and parameters

You can select the menus and parameters in the last line either

- sequentially from left to right using the spacebar, or
- from left to right (and vice versa) links using the "arrow to the right" and "arrow to the left" keys.

The currently selected parameter is displayed in reverse video. When you confirm your selection with **[ENTER]**, the corresponding menu appears.

Entering **[Ctrl]+[C]** (displayed as **<^C>** in the last menu line) returns you to the higher level menu. On German keyboards this corresponds to **[Strg]+[C]**.

Other entry options are described for the various menus.

Reporting a disruption to the connection between ROBAR-SV and ROBAR-CL

When a connection between ROBAR-SV and ROBAR-CL is disrupted or lost, a message to this effect is issued in the display of the ongoing ROBAR actions. The ongoing ROBAR actions are displayed in the `DISPLAY` (graphical display) and `MANUAL` menus, see [page 154](#).

Terminating the menu program

Terminate the `robar` menu program correctly by selecting the `EXIT` parameter in the main menu. However, this does **not** terminate the current ROBAR processes.

5.4 Controlling ROBAR operation using the “robar” menu program

You select the `robar` menus from the main menu. This section describes the menus and their parameters in alphabetical order.

Overview of the “robar” menus

Menus	Meaning
<code>DEFINES</code>	Manage ROBAR rule files
<code>DISPLAY</code>	Display ROBAR actions and configurations
<code>EXIT</code>	Exit <code>robar</code> menu program
<code>FREEPOOL</code>	Manage ROBAR freepool ¹
<code>INSTANCES</code>	Manage ROBAR-SV instances ²
<code>LIST</code>	Manage trace files; display statistics ³
<code>MANUAL</code>	Enter command:manually ⁴
<code>REPAIR</code>	Manage error information
<code>SAVE</code>	Save diagnostic data
<code>START</code>	Start ROBAR processes
<code>STOP</code>	Stop ROBAR processes

¹ ABBA interface only

² This menu is not available when called using the ROBAR-SV Manager; the ROBAR-SV instance is preselected

³ These parameter have no effect at the SCSI interface.

⁴ Number of commands depends on the interface used

DEFINES

Manage ROBAR rule files

Application area: SCSI and ABBA interface

The `DEFINES` menu is supported for compatibility reasons only (if ROBAR rule files from an earlier ROBAR version are to be used).

The `DEFINES` menu allows you to branch to the menu for managing the ROBAR rule files for the ROBAR-SV instance selected in the `INSTANCES` menu. These files contain default values. You can change them at your own discretion to meet any special requirements your data center might have. For a detailed description, see the [chapter "ROBAR rule files" on page 247](#).

`DEFINES` provides the following parameters for managing the ROBAR rule files:

ERRDEF

Edit `error_defines` file.

With this parameter you can edit the `error_defines` file using the default editor. This file contains the measures to be taken if serious errors occur.

EXIT

Returns you to the main menu.

MESS

edit `message_file`.

All messages requiring a response from the ROBAR system are stored in `message_file`. Using the `MESS` parameter, you can add new messages or modify or delete existing ones using the default editor. You must write the message texts in uppercase letters.

PUBLISH

Checks and activates ROBAR rule files.

This call first of all performs a consistency check on the various RRF sets of the selected ROBAR-SV instance using the `check_rrf` command. Error messages or warnings are output in the status line. When the check is successful (errorfree or only warning), the `publish_rrf` command is then executed.

RESP

Edit `message_resp` file.

All BS2000 actions which are initiated by ROBAR are stored in the `message_resp` file in the form of keywords. The `RESP` parameter allows you to edit this file using the default editor. You can enter, for example, actions such as responses to BS2000 messages or display message texts on the console.

ROBCMDS

Edit `roboter_cmds` file.

All archive system commands are stored together with their operands in the `roboter_cmds` file. The `ROBCMDS` parameter allows you to edit this file using the default editor. In this file, you may change only the identifier for device allocation and for output in the `MANUAL` menu.

SHOW

Display the actions for a particular message from `message_file`.

This parameter is used to display the BS2000 or archive system messages stored for a specific action code defined in `message_file`. You are asked to enter a five-position action code from `message_file` (MFxxx). Where multi ROBAR rule files are supported, only the main directory is displayed. The subdirectories for device-specific messages are not displayed.

DISPLAY

Monitor ROBAR actions

Application area: SCSI and ABBA interface

The `DISPLAY` menu keeps you informed of current ROBAR actions and of the configuration, i.e. current device assignment for the ROBAR-SV instance selected in the `INSTANCES` menu.

You can select whether the configuration showing the current device assignment is to be displayed graphically or in the form of a table:

`g` or `ENTER` configuration is displayed graphically

`t` configuration is displayed in a table

`Ctrl` + `C` Return to main menu

If you choose one of the two display options, a follow-up screen that is divided into a number of sections appears:

- Title line
Displays the application parameter currently valid.
- Upper section
Displays all ongoing ROBAR actions, i.e. current communication between the ROBAR-SV instance and the archive system or between the ROBAR-SV instance and the BS2000 systems. Each archive system command sent from ROBAR-SV to the archive system is flagged with the current time. The ROBAR actions are also logged in trace files.
A corresponding message is displayed when a connection between ROBAR-SV and ROBAR-CL is disrupted or lost.
- Middle section
Displays all BS2000 systems connected to the ROBAR-SV instance. If a host is displayed in reverse video, it is attached; if displayed at reduced intensity, it is detached.
- Lower section
Displays the MTC devices belonging to the configuration. Each device is identified by its device mnemonic, its associated BS2000 system and the volume (VSN) mounted in the device.
If a device has the status `DETACH PENDING`, the BS2000 system identifier displays attached.

The title bar contains the following information:

Field name	Information	Value	Meaning
CONFIG	Name of the configuration file current being used		
LOCATION	Name of the storage location defined in the configuration file		
ROBAR	Status of the ROBAR-SV instance (if a <code>robar_abba</code> process is terminated abnormally, the displayed value is shown only at half intensity)	STOPPED RUNNING	The ROBAR-SV instance has not been started yet. The ROBAR-SV instance is executing.
AMUx	Identifies the connected AMU (x=1 or 2) and the status. If the ROBAR-SV instance is running, the status is displayed as bright, otherwise the last known status is displayed at half-intensity	ACTIVE PASSIVE OFF	The AMU is currently active The AMU is currently inactive The AMU with which a connection is to be established cannot currently be accessed
ROB1	Status of the robot arm	ON OF	The robot arm is ready for use The robot arm is not ready for use

The screen display is controlled by the following entries:

- Ctrl** + **C** Terminate the DISPLAY menu, return to the main menu
- Display the next page with MTC devices (if the page displayed is the last one, the first page is displayed)
- h** Display the next group with BS2000 systems (if the page being displayed is the last one, the first page is displayed)
- v** Change from TSN to VSN display. If VSN display was already active, the effect is the same as pressing the space bar
- t** Change from VSN to TSN display. If TSN display was already active, the effect is the same as pressing the space bar
- x** Change between the tabular and graphical display format
- i** You can switch between the VSN and TSN modes using the **v** and **t** keys. Pressing the same key twice does not change the mode (VSN or TSN). Instead the page is changed, i.e. the next group of devices is displayed.

Tabular display of the configuration

A maximum of 40 BS2000 systems and 45 devices can be displayed on the screen. To display more than this number, scroll forward. If a configuration comprises fewer than 45 devices, the upper area is extended accordingly. This means that the previous ROBAR actions remain visible for longer.

Devices which are entered in the configuration but do not belong to the archive are displayed at low intensity.

```

CONFIG cs_eu1e_conf      |LOCATION ROBEULE |ROBAR RUNNING|AMU1 ACTIVE|ROB1 ON
-----
-->ROB      : 75 417      <6075,MO  , ,  ,1,1,05A,BAB720,  ,  ,
,20/152349>
<--ROB      : 75 417      <6075,MO  ,P,  ,1,1,05A,BAB720,  ,  ,
,20/152608>

-->417      :      %  ROB4008 TAPE CARTRIDGE MOUNTED (DEV=5A  / TSN=2IVY / VSN=BA
B720)
<--417      :      TM %NKVT010 BAB720 5A
                                                MF009
-----
01=417

00150 :      00151 :      00152 :      00153 :      00154 :
00155 :      00156 :      00157 :      00158 :      00159 :
0015A :BAB720 0015B :      0015C :      0015D :      0015E :
0015F :

-----
Stop=<AC>;Next hosts=<h>;Next devices=<SPACE>,VSN=<v>,TSN=<t>;Change mode=<x>
    
```

Figure 11: DISPLAY screen, tabular display of the configuration

The screen display is controlled by the following entries:

- Ctrl** + **C** Terminate the DISPLAY menu, return to the main menu
- Display the next page with MTC devices (if the page displayed is the last one, the first page is displayed)
- h** Display the next group with BS2000 systems (if the page being displayed is the last one, the first page is displayed)
- v** Change from TSN to VSN display. If VSN display was already active, the effect is the same as pressing the space bar
- t** Change from VSN to TSN display. If TSN display was already active, the effect is the same as pressing the space bar
- x** Change between the tabular and graphical display format



You can switch between the `VSN` and `TSN` modes using the `⏏` and `⏏` keys. Pressing the same key twice does not change the mode (`VSN` or `TSN`). Instead the page is changed, i.e. the next group of devices is displayed.

EXIT

Terminate “robar” menu program

Selecting `EXIT` from the main menu terminates the `robar` menu program.

The currently running `ROBAR-SV` instances and `ROBAR` processes, however, are **not** terminated, i.e. the links to the `BS2000` hosts and to the archive system are still active. How `ROBAR-SV` instances are stopped is described in the [section “Stopping a `ROBAR-SV` instance” on page 44](#) .

The `ROBAR-SV` instance selected most recently in the `INSTANCES` menu continues to remain selected when the menu program is called again in the Linux shell.

FREEPOOL

Manage ROBAR standard freepool

Application area: ABBA interface

The FREEPOOL menu is used to manage MTCs which are to be mounted in response to non-specific volume requests.



You should only select the FREEPOOL menu if you are **not** using MAREN. If you are using MAREN, the functionality of the FREEPOOL menu is covered by the MAREN volume management system. MAREN should therefore be used.

You must enter the VSNs of these cartridges in the ROBAR freepool files.

There are two types of freepool:

- the ROBAR standard freepool
- the task-specific ROBAR freepool, which you can create only via the ROBAR-CL-SDF user program using the ROBAR-CL-SDF statement `CREATE-ROBAR-FREEPOOL`

FREEPOOL manages only the ROBAR standard freepool. Cartridges for non-specific volume requests are removed from it only if no task-specific ROBAR freepool exists.

FREEPOOL provides the following parameters for managing the ROBAR standard freepool:

CREATE

Create and extend freepool, add VSNs.

This parameter allows you to create or extend the ROBAR standard freepool using the default editor. During ROBAR-SV installation, the editor was configured in the `ROBAR_EDITOR` configuration parameter (see [page 210](#)). The default editor is `vi`.

When you have called `CREATE`, the default editor is called. There you can enter the MTCs which are to be added to the standard freepool. The cartridges are addressed by means of their VSNs. You can specify VSNs both individually and in ranges.

Note the following guidelines for entering VSNs:

- The VSN consists of six of the following characters: A..Z, a..z, 0..9, \$, @, #, * (but only in `*FRxxx` and `*CLxxx`).
- when specifying VSN ranges (e.g. `ARCHxx-ARCHyy`), `xx` and `yy` must be numbers. The letters in the number range must correspond as they are used to define the start and end of the number range.
- The first VSN may not be greater than the last VSN.
- The first and last VSNs in the VSN range are separated by a hyphen (-).
- The first and last VSNs in the VSN range have the same length.
- VSNs and VSN ranges in a list must be separated by commas
- there must be no blanks

- Any number of hyphens ("-") or commas (",") are permitted at the end of the list.

A possible entry might be:

```
A00001-A00030,B00003,B00005,B00010-B00015,-----
```

If they have been entered correctly, the VSNs are stored in the `freepool/fpstd` file. If this file already exists, the new numbers are added to it; otherwise the file is created.

Even if only one of your entries in a list of several VSNs contains a syntax error, the message `Invalid VSN specifications` appears in the last line and the `freepool/fpstd` file is neither extended nor created. Even the syntactically correct VSNs are not entered in the file. Call `CREATE` again to display the most recently entered VSNs; now you can correct your errors.

When you quit the editor, the system automatically checks whether your entries are unique (see [page 161](#)).

DELETE

Delete entire freepool.

You use this parameter to delete the ROBAR standard freepool immediately. No warning is displayed.

EDIT

Edit freepool, e.g. delete individual VSNs.

You use this parameter to edit the ROBAR standard freepool using the default editor. During ROBAR-SV installation, the editor was configured in the `ROBAR_EDITOR` configuration parameter (see [page 210](#)). The default editor is `vi`.

You can use `EDIT` to delete or add individual VSNs. For entering large ranges of VSNs you are advised to use the `CREATE` parameter.

When you call the editor, the last line displays the warning: `Warning: using the editor may result in inconsistencies. This warning informs you that the structure of the freepool/fpstd file created with CREATE could be destroyed, with the result that other menus, such as SHOW, can no longer read the standard freepool correctly. When you quit the editor, the system automatically checks whether your entries are unique (see page 161).`

EXIT

Return to the main menu.

PRINT

Print freepool.

You use this parameter to print the ROBAR standard freepool on the default printer.

SHOW

Display freepool.

You use this parameter to display the VSNs of the ROBAR standard freepool.

If the list of VSNs takes up more than one screen, you can page forward with the **ENTER** key and terminate output of the list with **Ctrl** + **C**. If you are on the last screen page, you can terminate output of the list with **ENTER**. The screen is then deleted and the freepool menu reappears.

Checking for uniqueness after editing the standard freepool

ROBAR checks whether the VSNs of the new MTCs are already in the standard freepool or in one of the task-specific freepools created.

When you quit the editor after using the **CREATE** and **EDIT** parameters, the system automatically checks whether your entries are unique. When the check is completed, all VSNs which are not unique are displayed in a list. Each VSN is displayed only once, even if it appears more than once in the various pools.

If this list of non-unique VSNs covers more than one screen, you can page forward by pressing the **ENTER** key

When you press **Ctrl** + **C**, list output is terminated, the screen is deleted, and the following question is output in the last line:

Do you want to print out the list of non-unique VSNs (y/n)?

If you enter **y**, a list is printed on the default printer with the header *The following VSNs of the standard freepool are not unique.* You are then returned to the FREEPOOL menu.

If you enter **n**, the freepool menu reappears.



VSNs which appear more than once are **not** automatically deleted. You can delete them yourself using the **EDIT** parameter.

INSTANCES Manage ROBAR-SV instances

Application area: SCSI and ABBA interface

INSTANCES branches to a menu in which you can manage configured ROBAR-SV instances. This menu is not available when called using the ROBAR-SV Manager; the ROBAR-SV instance is preselected.

ROBAR-SV instances are configured via the ROBAR-SV Manager (see [page 123](#)) or by creating their interface-specific configuration file (see [page 212](#)).

The menu displays a list of the ROBAR-SV instances which are currently configured and their statuses. The list is sorted according to the status of the ROBAR-SV instances (first the sample configuration file, then the ROBAR-SV instances in the RUNNING status, then STOPPED, then DEFINED).

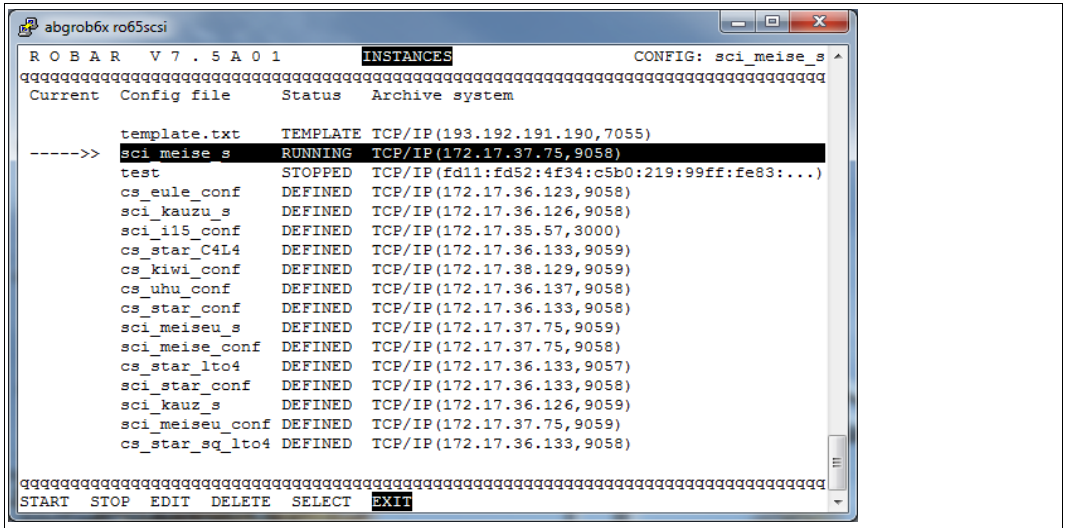

Figure 12: Menu for managing the ROBAR-SV instances (ABBA interface)

The ROBAR-SV instance currently selected is indicated by an arrow in the `Current` column. The name of the associated interface-specific configuration file is also displayed in the header behind the keyword `CONFIG`.

When you wish to perform an action for an instance in the `INSTANCES` menu, first specify inverse highlighting for the instance concerned using the "up arrow" or "down arrow" key. You can then execute the required action on the highlighted instance.



Actions of the other menus are executed for a **selected** ROBAR-SV instance. To do this, select a ROBAR-SV instance in the `INSTANCES` menu (see above) and the `SELECT` action.

The first time the menu program is started no ROBAR-SV instance is selected. The first instance in the list will be highlighted.

Following a restart of the menu program, the ROBAR-SV instance selected most recently will once again be displayed as the selected ROBAR-SV instance.

The name of the ROBAR-SV instance is displayed in the `Config file` column. It corresponds to the name of the associated interface-specific configuration file.

The `Status` column displays the status of the ROBAR-SV instance. ROBAR-SV instances can have the following statuses:

DEFINED	The ROBAR-SV instance is configured, i.e. the interface-specific configuration file exists.
RUNNING	The runtime files of the ROBAR-SV instance are configured and the ROBAR processes are running. A connection exists to an archive system.
STOPPED	The ROBAR-SV instance was stopped. The configuration file and other working files still exist. No connection exists to an archive system.
TEMPLATE	Designates the sample configuration file. It can only be edited.

The `Archive system` column displays the type of connection to the archive system, i.e. the value of the `robot_address1` configuration parameter.

INSTANCES provides the following parameters:

DELETE

After the relevant question has been answered, removes the ROBAR-SV instance from ongoing operation. Its files, including the configuration file, will be deleted.

EDIT

Calls the preset editor to edit the interface-specific configuration file of the ROBAR-SV instance.

You can also edit the interface-specific configuration file of a running ROBAR-SV instance. The changes will, however, only take effect when the instance has been restarted.

EXIT

Returns you to the main menu.

SELECT

Selects the ROBAR-SV instance highlighted using the "up arrow" or "down arrow" key and resets the arrow in the `Current` column. Further actions are performed for this instance.

START

Starts the selected ROBAR-SV instance. Following successful execution the instance is placed in the RUNNING status.

Before starting a ROBAR-SV instance in ROBAR operation for the first time, please also observe the information in the [section "Requirements for ROBAR operation" on page 36](#).

STOP

Stops the ROBAR processes of the selected ROBAR-SV instance. The instance is placed in the STOPPED status.

LIST

Obtain information on trace files and archive number ranges

Application area: SCSI interface (some parameters have no effect) and ABBA interface

The LIST menu is used to branch to a menu from which you can view, evaluate, print or delete the trace files of the ROBAR-SV instance selected in the INSTANCES menu.

The trace files log all ROBAR-SV instance actions, see [page 50](#).

The menu also gives you access to information on the various ROBAR archive number ranges. You can request the following information:

- all the archive numbers permitted for the ROBAR system in the archive record (contents of the ROBAR_ARCHIV configuration parameter - see [page 218](#))
- all foreign cartridge locations and their cartridges
- all dynamic extensions of the VSN range for foreign cartridges (contents of the ROBAR_ARCHIV configuration parameter - see [page 218](#))

LIST provides the following parameters:

DELETE

Delete trace files.

You must delete trace files regularly to avoid saturation of the disk memory.

Once the ROBAR processes have started, you may only delete the trace files which are suffixed with a time stamp. The current trace files (see [page 50](#)) cannot be deleted until the ROBAR processes have stopped running.

The names of all existing trace files are displayed.

When you have entered the file name and it has been checked, the specified trace file is deleted. This is logged in the last line.

If you hit **ENTER** instead of entering the file name, nothing is deleted and you are returned to the LIST menu.

EDIT

Edit trace files.

The names of all existing trace files are displayed.

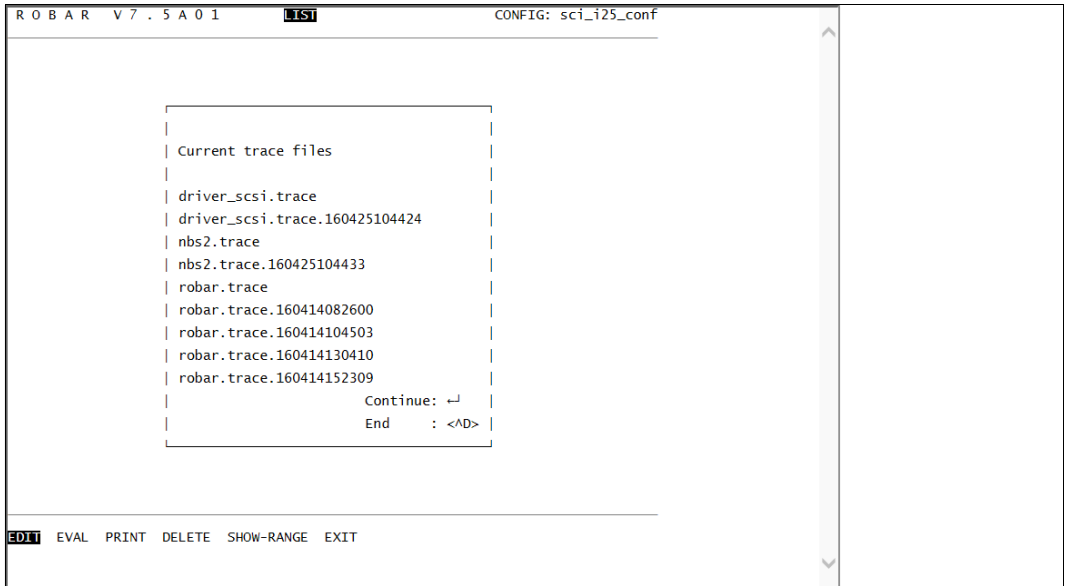

```
ROBAR V7.5A01 LIST CONFIG: sci_i25_conf
-----
Current trace files
driver_scsi.trace
driver_scsi.trace.160425104424
nbs2.trace
nbs2.trace.160425104433
robar.trace
robar.trace.160414082600
robar.trace.160414104503
robar.trace.160414130410
robar.trace.160414152309
Continue: ←
End : <AD>
-----
EDIT EVAL PRINT DELETE SHOW-RANGE EXIT
```

Figure 13: List of trace files

When you have entered the file name and it has been checked, the specified trace file is displayed.

In the trace file you can

- scroll forward and backward
- position the cursor
- search for a particular text
- log the screen outputs

```

ROBAR V 7 . 5 A 0 1      LIST                               Line: 000001
-----
RSV1057 Trace file (ROBAR V07.5A01) created at   2016-04-26 09:45:45

        with Release 0, Configuration file sci_i25_conf
<160426094545>  robar_abba5.c[1-2]: ... entering check_pipe (DISP, T)
<160426094545>  robar_abba2.c[1-2]: ... entering rech_att ()
<160426094545>  robar_abba1.c[1-2]: ... entering def_dat_lesen (rrf="STD,type=
X)
<160426094545>  robar_abba2.c[1-2]: ... entering xref_verarb ()
<160426094545>  robar_abba4.c[1-2]: ... entering resp_ausf (MR046: DELETE
SUBTASK,SUBTSN=tttt)
<160426094545>  robar_abba4.c[1-2]: ... entering unregister_tsn ()
<160426094545>  robar_abba2.c[1-2]: ... xref_verarb(): resp_ausf returns ()
<160426094545>  robar_abba1.c[1-2]: ... config file has been read
<160426094545>  robar_abba1.c[1-2]: ... tries to set lock on request file
<160426094545>  robar_abba1.c[1-2]: ... lock set on request file
<160426094545>  robar_abba1.c[1-2]: ... entering get_next_request () (pos=3701
22)
<160426094545>  robar_abba1.c[1-2]: ... lock on request file released
<160426094545>  robar_abba3.c[1-2]: ... entering abba_mld_les (P.600)
-----
Parameters: (<PRINT>, <CR>, +[int], -[int], f[int], s[string], e=EXIT)

```

Figure 14: Evaluating the trace files

You can control the evaluation with the following entries:

- PRINT** log the screen outputs
- ENTER** page forward one screen
- ↓** page forward one screen
- ↑** page backward one screen
- Home** position cursor at start of file
- +/-[int]** scroll forward [int] lines
- f[int]** position cursor in line [int]
- s[string]** search forward for [string]; you can specify the search direction using the arrow keys (instead of **ENTER**)
- s** search for the last entered [string]; you can specify the search direction using the arrow keys (instead of **ENTER**)
- e** return to the LIST menu

EVAL

Evaluate trace files for a specifiable period, i.e. compile statistics.

The names of the existing trace files are displayed.

You are asked to enter the following:

1. File name or **[ENTER]**:

Enter the name of the trace file to be evaluated. If you just hit **[ENTER]** instead of entering the first file name, you are returned to the LIST menu.



This message continues to appear until you hit **[ENTER]** instead of entering the file name. You can enter up to 10 trace files.

2. Enter the evaluation period or hit **[ENTER]**:

Specify the evaluation period in the format `ymmddhhmms s-ymmddhhmms s`. The system will then evaluate all trace entries made within this period. If you just hit **[ENTER]** instead of entering an evaluation period, all trace entries are evaluated.



The syntax of the time details is checked (date and time). A check is also performed as to whether the start and end times are logical.

3. Select the statistics

After specifying the trace file and the desired period, the statistics below can be compiled using the listed parameters:

Summary statistics	SUM parameter
Host statistics	HOST parameter
Statistics on manual inputs	MAN parameter
Cleaning statistics	CLEAN parameter
IMPORT/EXPORT statistics	IMP/EXP parameters
Inventory statistics	INV parameter
Error statistics	ERROR parameter

The statistics and their report lists are described on [page 341](#).

The statistics are compiled once you have selected the appropriate parameter. You can then select the next type of statistics.

4. Displaying the statistics The **SHOW** parameter displays the created statistics on the screen using an editor.

5. Print the statistics

You can print statistics that have been created on the default printer using the `PRINT` parameter.

EXIT

Return to the main menu.

PRINT

Print statistics created using `EVAL` for a specified period.

The names of all existing trace files are displayed.

When you have specified the desired trace file, you will be asked whether the entire file is to be printed or only an excerpt covering a certain period. You must enter this evaluation period in the format `yyymmddhhmmss-yyymmddhhmmss` or only with `[ENTER]`. If you just hit `[ENTER]`, all trace entries are printed, otherwise only the entries made during the specified period.

The selected trace file is printed on the default printer.

In the trace file to be printed, any entries beyond column 80 are continued in the next line.

If you hit `[ENTER]` instead of entering the file name, nothing is printed and you are returned to the `LIST` menu.



The syntax of the time details is checked (date and time). A check is also performed as to whether the start and end times are logical.

SHOW-CLEANER

Generate list relating to the usage of the cleaning cartridge.

This parameter has no effect at the SCSI interface.

SHOW-FOREIGN

Output a list of the archive numbers (VSNs) of the imported foreign cartridges and their positions in the archive.

This parameter has no effect at the SCSI interface.

If the `ROBAR_FOREIGN.<instance>` file exists, the `LIST` menu also offers information on the status ("assigned" or "free") of all foreign cartridge locations declared in the `ROBAR_FOREIGN.<instance>` file.

SHOW-RANGE

Output information on the contents of the configuration parameter `ROBAR_ARCHIV` (see [page 218](#)), the foreign cartridge locations and their archive numbers and on the dynamically added volumes.

The output information "foreign cartridges" and "additional volumes" does not appear at the SCSI interface.

Observe the following with regard to the foreign cartridges:

- If the foreign cartridges for a ROBAR-SV instance are defined through the `ROBAR_FOREIGN.<instance>` file, the section of the `ROBAR_ARCHIV` configuration parameter that refers to the foreign cartridge is ignored and instead the foreign cartridge range from the `ROBAR_FOREIGN.<instance>` file is used.
- The `SHOW-RANGE` parameter only informs you of the archive numbers for the foreign cartridge locations. Full information on the foreign cartridges and on their storing positions in the archive system is obtainable with the `SHOW-FOREIGN` parameter.

MANUAL

Enter archive system commands manually

Application area: SCSI and ABBA interface

If you select **MANUAL**, you branch to a menu in which the archive system commands and the BS2000 command **/UNLOAD-TAPE** can be entered manually. The archive system commands apply for the archive system which manages the ROBAR-SV instance selected in the **INSTANCES** menu.

The archive system commands available differ according to the interface. Commands which have been marked accordingly are listed in the last line (see [page 174](#)). The commands can be varied using operands (see [page 304](#)).

The selected command is displayed together with its operands, e.g. the archive system command **MO**:

```
<M011,MO , ,FFFF,1,r,0mm,vvvvvv,ss,AAAAAAAA,BBBBBBBB,UUUUUUUU>
```

You must modify the operands (written in lower case) (see ["General notes on the archive system commands" on page 173](#)) and confirm with **[ENTER]**. The command is then sent, suffixed with the current time, to the archive system (the **/UNLOAD-TAPE** command to the corresponding BS2000 system), where it is executed.

Both the archive system commands and the archive system return messages are logged in the scroll area (lines 3 - 23 on the screen). The archive system acknowledges whether the command was successful or not. If it was unsuccessful, an error code is also output.

You can cancel a selected archive system command by pressing **[Ctrl] + [C]**.

```
CONFIG sci_i56_conf      |LOCATION ROBI56  |ROBAR RUNNING|AMU1 ACTIVE|ROB1 ON
-----
<--417      : 2IQ9 %ARC0018
                                     MF855
<--417      : 2IRA %ARC0018
                                     MF855
<--417      : 2IRB %ARC0018
                                     MF855
<--417      : 2IRC %ARC0018
                                     MF855
<--417      : 2IRD %ARC0018
                                     MF855
-----
MO KE EJ IN ULV ULK EJT EJP /UNL EXIT
```

Figure 15: Menu for manual command input

General notes on the archive system commands

For the structure of the archive system commands, see the documentation of the manufacturer [15]. The mandatory operands of the archive system commands are represented by the following lowercase characters in the command displays and must be supplied with values:

r	Archive system; permissible entries: 1 (single-robot system)
z	Robot number in the archive system command ROSA
mm	Device mnemonic (in the case of 2-character BS2000 MNs) or devname (in the case of 4-character BS2000 MNs) of the MTC device
vvvvvv	VSN of the volume
ss	Archive system status byte
aaaaaaaa	Source coordinate <ul style="list-style-type: none"> – With the UNLOAD-TAPE command, the name of the BS2000 system on which the command is to be issued must be specified. – for the EJP and EJTP command the source coordinate is the first VSN in the range
bbbbbbbb	Target coordinate In the EJP and EJTP commands the target coordinate is the last VSN in the range
hhh	Simulation mode for the archive system command MAN (ABBA interface)

The commands IN and IV (for importing MTCs) and the commands EJ, EJT, EJP and EJTP (for exporting MTCs) are assigned an additional field that is blank by default. At the ABBA interface you can use this field, depending on how it is occupied (iii or eee), to perform MTC import/export for input/output areas that deviate from the predefined input/output areas:

iii	If you enter Ixx in the field, an MTC import can be performed for input/output areas which deviate from the predefined input/output areas:
eee	If you enter Exx in the field, an MTC export can be performed for input/output areas which deviate from the predefined input/output areas:

You cannot change the operands represented by uppercase letters. These are return values from the archive system to ROBAR-SV.

Short description of the archive system commands

The archive system commands displayed by default in the menu bar of the MANUAL menu have the identifier H in column 10 of the interface-specific `roboter_cmds` file. The table below shows the name and brief description of all available archive system commands, including the commands which do not appear in the MANUAL menu:

Archive system command	Short description
ACOM	Query robot status
AOFF ¹	Shut down AMU
AUTO	Deactivate robot simulation
BON ¹	Switch on barcode check
BOFF ¹	Switch off barcode check
CLU ¹	Close device Id
CVA ^{2 3}	Pseudo archive system command to reset the fast mount attribute (for ETERNUS CS only)
DL ¹	Update VSN and archive record entry for specified coordinate
EJ ^{1 3 4}	Move cartridge to output area (export). ABBA interface: the cartridge's position in the archive is reserved, the archive record entry is retained. SCSI interface: the cartridge's position in the archive is released, the archive record entry is deleted (like EJT).
EJP ^{1 2 4}	Generate a sequence of EJ commands for a specified VSN number range, see page 176
EJT ^{1 2 3 4}	Move cartridge to output area (export); the cartridge's position in the archive is released, the archive record entry is deleted
EJTC ¹	Move used cleaning cartridge to the output area (export)
EJTP ^{1 2}	Generate a sequence of EJT commands for a specified VSN number range, see page 176
EXIT ²	Return to main menu
IN ^{1 4}	Move cartridge(s) from the output area to the archive
INC ¹	Check archive position for specified coordinate
INSC ^{1 2}	Move cleaning cartridge from the input area to the archive
IVK ¹	Check archive position for a specified coordinate range
IVV ¹	Check position of the specified VSN in the archive
KE ^{3 4}	Remove cartridge or cleaning cartridge from device
KEC ¹	Remove cartridge from device and move to specific storing position
MAN ¹	Activate robot simulation

Archive system command	Short description
MO ^{3 4}	Mount cartridge or cleaning cartridge on device
MO ²	Fast mount (for ETERNUS CS only)
MOCL ^{1 5}	Mount cleaning cartridge on device (cartridge is automatically removed from the device after cleaning)
MV ¹	Move cartridge from source coordinate to target coordinate
ROSA	Start robot
ROSO ¹	Stop robot
SIN ¹	Stop insert run
SIVK ¹	Stop inventory run
ULU	Initiate emergency unload for specific MTC device
ULV ^{3 4}	Output archive record entry for a specific VSN
ULK ^{3 4}	Output archive record entry for a specific coordinate or for a specific MTC device
UPV ¹	Output archive record entry for a specific VSN
UPK ¹	Modify the status field in the archive record for the specified coordinate
VI ¹	Move individual cartridge from the input area to the archive
VICC ¹	Move individual cartridge from the specified input area coordinate to the target coordinate
/UNLOAD mn, SYSTEM=aaaaaa 1 3 4	Generate /UNLOAD-TAPE command on the BS2000 system to which the device is allocated (unload MTC device) mn = Mnemonic device name of the MTC device aaaaaa = Name of the BS2000 system

¹ Rejected by ETERNUS CS with return code N017

² Not a true archive system command

³ In the MANUAL menu with RRF ETERNUS CS (ABBA interface)

⁴ In the menu MANUAL with RRF SCSI (SCSI interface)

⁵ Use via menu not released

Archive system commands EJP and EJTP

You can use the command `EJP` (eject pool) to export MTCs with a range of VSNs in ascending order. The `EJP` command is used to generate `n` archive system commands `EJ` (eject), where `n` is the number of cartridges.

To prevent the current ROBAR session from being blocked while the cartridges are exported, you can prioritize the `EJP` command. When you have issued the `EJP` command, you are asked for the priority of the command.

You may enter any of the following:

- `h` The individual `EJ` commands are executed with the highest priority as before, i.e. ahead of all other jobs with normal or lower priority.
- `l` The jobs are written to the job file with lower priority, i.e. all other jobs with higher or normal priority are executed first.
- `n` The individual jobs are issued without priority, i.e. high-priority jobs are executed before them and low-priority jobs after them.

The command `EJTP` (eject total pool) is identical to the `EJP` command, with the distinction that a sequence of `EJT` commands is generated for a specified VSN number range.



If MAREN is being used, it is informed about the export.

Archive system command MO

You use the `MO` (mount) command to mount an MTC on a specific MTC device. The following specifications in the `SS` field control the fast mount attribute for ETERNUS CS:

`SS = _ _` Mount without fast mount attribute

`SS = s _` Mount with fast mount attribute

In the trace file you can

- scroll forward and backward
- position the cursor
- search for a particular text
- log the screen outputs

You can control the evaluation with the following entries:

PRINT	log the screen outputs
ENTER	page forward one screen
↓	page forward one screen
↑	page backward one screen
Home	position cursor at start of file
+/-[int]	scroll forward [int] lines
f[int]	position cursor in line [int]
s[string]	search forward for [string]; you can specify the search direction using the arrow keys (instead of ENTER)
s	search for the last entered [string]; you can specify the search direction using the arrow keys (instead of ENTER)
e	return to the REPAIR menu

REPAIR

Resets the error counter for a device or volume and deletes the associated error information.

After the faulty device or volume has been entered and it has been checked, the error information in the file `/var/lib/<interface>/<instance>/error_history` is deleted.

EXIT

Return to the main menu.

SAVE

Save diagnostic data

As an alternative to creation of diagnostic data with a script, you can also create the diagnostic documentation required for the ROBAR server using `SAVE`.

See also the [section "Diagnostic documentation for the ROBAR server" on page 328](#).

When you have selected `SAVE`, you are asked in the last line whether you are ready for the diagnostic save operation. If you press `[n]`, no diagnostic backup is made and the main menu reappears.

If you press `[y]`, the diagnostic backup starts. During the backup run the following message is displayed: `The diagnostic data is being transmitted`

If the data was transmitted successfully, the following message appears in the last line: `Data backup completed successfully (continue with <CR>)`

Press `[ENTER]` to return to the main menu.

If a write error occurs during the backup run, the run is aborted.



As long as the write operation has not yet been started, you can abort backup of the diagnostic data by pressing `[Ctrl]+[C]`.

Diagnostic data is by default saved in the `/var/opt/fujitsu/robar` directory. You can change the directory using the configuration parameter `ROBAR_SAVE_DIR` (see [page 211](#)).

START

Start ROBAR-SV instance.

As an alternative to starting a ROBAR-SV instance in the `INSTANCES` menu, you can also start a ROBAR-SV instance using `START`. The ROBAR-SV instance selected most recently in the `INSTANCES` menu is preset, i.e. the name of its interface-specific configuration file is displayed. In both cases you start the ROBAR-SV processes for communicating with the archive system and with the BS2000 systems.

Before starting a ROBAR-SV instance in ROBAR operation for the first time, please also observe the information in the [section "Requirements for ROBAR operation" on page 36](#).

When you select the `START` menu, a form appears for starting the ROBAR-SV instance (communication with the archive system) and the ROBAR-CMX processes (communication with BS2000). In addition, obsolete trace files of the ROBAR-SV instance can be deleted.

You move from one form field to another using the "arrow up" or "arrow down" keys.

Pressing the `ENTER` key starts the ROBAR-SV instance. The connection setup to the archive system or the BS2000 system is logged in the last line. Then the main menu reappears.

```

ROBAR V 7 . 5 A 0 1      START      CONFIG: sci_i25_conf
-----
Configuration file      : sci_i25_conf
Start ROBAR-CMX        : 
Delete trace files     : 
Change to DISPLAY mode : 
-----
CONTINUE  EXIT
  
```

Figure 17: Menu for starting a ROBAR-SV instance

Definition of the form fields

configuration file

Name of the configuration file (= name of the ROBAR-SV instance). This form field cannot be changed.

Start ROBAR-CMX

Connection setup of ROBAR-SV to the BS2000 system.

Press the spacebar to select either:

- y: start ROBAR-CMX, or
- n: do not start ROBAR-CMX

Delete trace files

Press the spacebar to select either:

- y Deletion of trace files

The following trace files are deleted:

- CMX trace files (*inotrc.**)
- Trace files of the ROBAR-SV instance
- Backed-up trace files (see `RECOVER_DISK_FULL` script, [page 54](#))

- n Rename the trace files to `xxx.<timestamp>`
(`xxx` = file name of the trace file)

Change to DISPLAY mode

Press the spacebar to select either:

- n: return to the main menu
- g: change directly to DISPLAY mode with graphical display
- t: change directly to DISPLAY mode with tabular display

START provides the following parameters:

CONTINUE

Starts the selected ROBAR-SV instance.

EXIT

Returns you to the main menu without starting the ROBAR-SV instance.

STOP

Terminate ROBAR-SV instance

As an alternative to stopping a ROBAR-SV instance in the `INSTANCES` menu, you can also stop a ROBAR-SV instance using `STOP`. The ROBAR-SV instance selected most recently in the `INSTANCES` menu is stopped together with its active ROBAR processes. In the last menu line you are asked: Do you really want to stop the ROBAR instance (y/n)?.

Pressing `y` terminates all ROBAR processes of the selected ROBAR-SV instance. The connections to the archive system system and to the BS2000 hosts are disconnected and this is logged in the last line. The parameter line of the main menu is then displayed.

Pressing `n` returns you immediately to the main menu without terminating the ROBAR processes.

The menu program itself is not terminated by `STOP`, but by means of `EXIT` in the main menu.

You can also terminate a ROBAR-SV instance without the menu using the `robar_stop` program.



Before you enter `STOP`, check that all actions have been terminated correctly. This applies particularly to archive system block commands such as `IN`. If you terminate the ROBAR processes prematurely, inconsistencies may occur in the data or messages may not be answered.

5.5 Ignoring obsolete messages (DISCARD_MSG)

If the message queue contains obsolete messages, then you can delete them with the ROBAR-SV statement `DISCARD_MSG`, see [page 280](#). For this, messages contained in the message queue (`.../cmx/robar.mess`) are compared with the parameters of the `DISCARD_MSG` statement. The entries that refer to the same device or cartridge and that have not yet been processed are marked as invalid.

Note that only the messages present in the file at the time the command is issued are deleted, not the messages that are added after the command was issued.

If an error occurs (e.g. LDCK- Load Check) while a cartridge is being mounted in a device, the following events ensue:

- NDM issues message `NKVT013` and instructs ROBAR to mount the cartridge in a device.
- The robot inserts the cartridge in a device. This causes an LDCK error.
- The device error recovery issues message `EXC0858`. Via inserts, this message informs you of the error that occurred and of the affected device.
- The TM (tape monitor) task deletes the current `NKVT013` message and NDM issues a new `NKVT013` message with the same information for the archive number and the mnemonic device name.
- The new `NKVT013` message is added to the ROBAR-SV message queue.

ROBAR's reaction depends on the value set for action key `MRV21` (see the ROBAR rule file `message_resp` on [page 273](#)):

- *delete current job* option
If ROBAR receives message `EXC0858` for an archive number, the relevant current job is deleted using the `/CHANGE-TAPE-MOUNT ACTION=CANCEL,UNIT=mn` command, as a result of which the MOUNT process for the cartridge has no basis. The commands `UNLOAD-TAPE` to the BS2000 system and `KEEP` to the archive system cause the defective cartridge to be removed from the device. The new message `NKVT013` for the archive number and for the device is removed from the message queue. This stops ROBAR from causing the cartridge to be mounted again as this would have undesired side effects (LDCK would occur again, the wrong cartridge would be mounted, etc.).

- *retry on another device option*
ROBAR issues the `/CHANGE-TAPE-MOUNT ACTION=MOVE,UNIT=mn` command in order to have the cartridge mounted in another device. This allows ROBAR to find out whether the error was caused by the cartridge or by the device. In this case, too, it is not necessary for the MOUNT to be completed on the first device. However, before the cartridge can be mounted on another device, it has to be removed from the device (by issuing the `UNLOAD-TAPE` command to the BS2000 system and `KEEP` to the archive system). The new message `NKVT013` for the archive number and for the first device is removed from the message queue.

6 Installation and configuration

This chapter provides information on how to install and configure the ROBAR software components ROBAR-CL (BS2000) and ROBAR-SV (Linux). These two components are supplied and installed separately.

A requirement for operation with ROBAR is that the connections from the BS2000 systems to the ROBAR server and from the ROBAR server to the archive systems are installed and configured. Information on this is provided in the [section “Connection of ROBAR-CL, ROBAR-SV, and the archive system” on page 193](#).

In [section “Upgrading from previous ROBAR versions” on page 244](#) you will find information on migrating from earlier ROBAR versions to the current ROBAR version.

6.1 Installing ROBAR-CL

The BS2000 component ROBAR-CL is shipped using the SOLIS delivery procedure and installed under any BS2000 user ID using the installation monitor IMON (see the “IMON” manual [6]).

Install ROBAR-CL on all BS2000 systems which are to participate in ROBAR operation.

Configuration of ROBAR-CL is described in the [section “Configuring ROBAR-CL” on page 187](#).



When upgrading from an earlier ROBAR version, please note the [“Notes for ROBAR-CL” on page 244](#).

Recommendation if MAREN is being used

Install ROBAR-CL under the same user ID as MAREN (\$SYSMAREN).

ROBAR-CL requires a maximum 2 Mbytes of static disk memory and a maximum 4 Mbytes of dynamic disk memory. The size of the dynamic disk memory depends on the trace files saved).

Setting up privileges

If you are using SECOS (see the “SECOS” manual [10]), the installation ID of ROBAR-CL requires the TAPE-ADMINISTRATION privilege (SRPM command /SET-PRIVILEGE PRIV=TAPE-ADMINISTRATION,USER-ID=<name>).

Installation files

The following files are shipped with ROBAR-CL:

SYSRPC.ROBAR-CL.<ver>	Procedure file for starting ROBAR-CL-DCAM
SYSMES.ROBAR-CL.<ver>	Message file
SYSPAR.ROBAR-CL.<ver>.MESSAGES	System messages relevant to ROBAR
SYSPAR.ROBAR-CL.<ver>.PROZPARAM	Parameter file for procedure control
SYSPAR.ROBAR-CL.<ver>.TEXT.D	(for internal use, German)
SYSPAR.ROBAR-CL.<ver>.TEXT.E	(for internal use, English)
SYSPRG.ROBAR-CL.<ver>.DCAM	ROBAR-CL-DCAM application
SYSPRG.ROBAR-CL.<ver>.SDF	ROBAR-CL-SDF user program ¹
SYSSDF.ROBAR-CL.<ver>	System syntax file
SYSSII.ROBAR-CL.<ver>	Structural and installation information files for installation with IMON
SYSRPC.ROBAR-CL.<ver>.MAREN	Procedure file for the collection of information from the MAREN catalog
SYSFGM.ROBAR-CL.<ver>.D	Release Notice (German)
SYSFGM.ROBAR-CL.<ver>.E	Release Notice (English)

¹ The file SYSPRG.ROBAR-CL.<ver>.SDF is installed by IMON under the standard system ID (system parameter DEFLUID, default: \$TSOS).

Further files are created during a system run:

\$TSOS.ROBAR.TRACE. <DCAM-name>.<tsn>. <day>-<hour><minute> [.<folgenummer>]	BS2000 trace files created by ROBAR-CL-DCAM. The prefix \$TSOS.ROBAR can be modified in the ROBAR start file SYSRPC.ROBAR-CL.<ver> using the TRACE parameter, see page 188 .
SYSRPT.ROBAR-CL.<ver>. <DCAM-Name>.<tsn> or SYSRPT.ROBAR-CL.<ver>. <DCAM-Name>.SYSOUT	SYSOUT output of the ENTER job. The file name is defined in the SYSRPC.ROBAR-CL.<ver> file and can also have a different name. See also page 327 .
SYSPAR.ROBAR-CL.<ver>.TEXT	Copy of the internal message texts in German or in English (the language depends on the definitions made in the SYSRPC.ROBAR-CL.<ver> file)

6.2 Configuring ROBAR-CL

You can perform the following configuration steps in any order before ROBAR-CL is started for the first time.

Editing the message keys for ROBAR-CL

The file `SYSPAR.ROBAR-CL.<ver>.MESSAGES` contains the message numbers of the BS2000 system messages that are passed to ROBAR-SV (see [page 255](#)).

You can normally accept the file without modification. If required, you can use an editor (e.g. EDT) to adapt it to the system environment of your data center.

Editing the parameter file

If necessary, adjust the routing code for TYPE commands in the `SYSPAR.ROBAR-CL.<ver>.PROZPARAM` parameter file (see [page 259](#)).

Otherwise the file can normally be accepted without modifications.

Activating the syntax file

The system syntax file `SYSSDF.ROBAR-CL.<ver>` contains the system definitions for ROBAR-CL-SDF. It is enabled when installation with IMON takes place or retroactively using the `MODIFY-SDF-PARAMETERS` command.

Activating the BS2000 message file

The `SYSMES.ROBAR-CL.<ver>` file contains the messages and help texts for the product ROBAR-CL. The file is activated at the time of installation with IMON or later with the `MODIFY-MIP-PARAMETERS` or `MODIFY-MSG-FILE-ASSIGNMENT` command.

Default settings for the console

Set the system option (startup parameter service) `NBMSGCSD` to Y.

Network entries

The system support must make the necessary entries for the transport system (`/BCIN`, `/BCMAP`).

6.2.1 Modifying the start file for ROBAR-CL-DCAM

The start file `SYSPRC.ROBAR-CL.<ver>` for ROBAR-CL-DCAM is started via the command `/ENTER-PROCEDURE` or `/CALL-PROCEDURE`.

The ROBAR-CL-DCAM parameters are preset in the procedure supplied. They can be adjusted as required. In interactive mode they can also be queried while the procedure is running. In batch mode the parameters must be assigned the correct values in the `SYSPRC` file in the line where they are defined.

When multiple robot-operated archives are to be controlled, you must copy and adjust the file the requisite number of times (see also the information on the `PARTNER` and `JV-NAME` parameters).

Extract from the supplied file `SYSPRC.ROBAR-CL.<ver>`

```
/SET-PROC-OPTIONS DATA-ESCAPE-CHAR=STD,LOG-ALLOW=*YES
/"-----"
/BEGIN-PARAMETER-DECLARATION
/"-----"
/"      UID      : userid, where the ROBAR-CL-DCAM program is started  "
/DECLARE-PARAMETER NAME=UID(INIT='$SYSMAREN')
/"-----"
/"      PARTNER   : name of the DCAM application (8 characters)        "
/DECLARE-PARAMETER NAME=PARTNER(INIT='ROBAR1DC')
/"-----"
/"      JV-NAME   : job variable                                       "
/DECLARE-PARAMETER NAME=JV-NAME(INIT='*NONE')
/"-----"
/"      UCONID    : autorisation name for the UCON connection          "
/DECLARE-PARAMETER NAME=UCONID(INIT='CON1')
/"-----"
/"      UCONPWD   : UCON password (1-8 characters) or '*NONE'         "
/DECLARE-PARAMETER NAME=UCONPWD(INIT='*NONE')
/"-----"
/"      OPEROLE   : Operator Role (1-8 characters) or '*NONE'         "
/"                  The routing codes *,T,E,N,G,U and A must be assigned "
/"                  to OPEROLE.                                         "
/"                  OPEROLE has no effect if UCONID is not set to *NONE. "
/DECLARE-PARAMETER NAME=OPEROLE(INIT='SYSADM')
/"-----"
/"      OPERID    : Operator Identifier (1-8 characters) or '*NONE'    "
/"                  OPERID has no effect if UCONID is not set to *NONE. "
/DECLARE-PARAMETER NAME=OPERID(INIT='TSOS')
/"-----"
/"      OPIDPWD   : Operator Id password (1-8 characters) or '*NONE'  "
/DECLARE-PARAMETER NAME=OPIDPWD(INIT='*NONE')
```

```

/-----"
/"      TRACE      : prefix for trace file name, to which ROBAR adds a      "
/"                  suffix up to 31 characters long. Allowed values:      "
/"                  [:catid:]$userid      "
/"                  or [:catid:][$userid.]composed_name_1..10      "
/DECLARE-PARAMETER NAME=TRACE(INIT='$TSOS.ROBAR')
/-----"
/"      TRACE-NBR  : trace records number pro file. 0=no trace written      "
/DECLARE-PARAMETER NAME=TRACE-NBR(INIT='10000')
/-----"
/"      PRIMARY   : PP for primary allocation of trace files      "
/DECLARE-PARAMETER NAME=PRIMARY(INIT='60')
/-----"
/"      SECONDARY  : PP for secondary allocation of trace files      "
/DECLARE-PARAMETER NAME=SECONDARY(INIT='30')
/-----"
/"      AUTO-REPLY: '-ar' switch must be removed (' ') when no      "
/"                  self answer function is used (PAUSE messages)      "
/DECLARE-PARAMETER NAME=AUTO-REPLY(INIT='-ar')
/-----"
/"      NO-TYPE    : '-nt' to suppress the sending of type      "
/"                  messages at console. Only PAUSE messages are sent.      "
/DECLARE-PARAMETER NAME=NO-TYPE(INIT=' ')
/-----"
/"      MARENLNK   : MAREN SYSLNK default pathname,      "
/"                  should always be set to *NONE,      "
/"                  is supported by compatibility reasons.      "
/DECLARE-PARAMETER NAME=MARENLNK(INIT='*NONE')
/-----"
/"      MARENREP   : MAREN SYSREP DEFAULT PATHNAME      "
/DECLARE-PARAMETER NAME=MARENREP(INIT='*NONE')
/-----"
/"      MARENPWD   : MAREN password (1-8 characters)      "
/DECLARE-PARAMETER NAME=MARENPWD(INIT='*NONE')
/-----"
/"      DUMP       : YES = Allow to get a user-dump when needed      "
/DECLARE-PARAMETER NAME=DUMP(INIT='YES')
/-----"
/DECLARE-PARAMETER NAME=VERSION(INIT='<ver>')
/-----"
/DECLARE-PARAMETER NAME=LANGUAGE(INIT='D')
/-----"
/END-PARAMETER-DECLARATION
/-----"
. . .

```

Notes

The notes on the parameters of the start file are arranged below in the order of their occurrence.

PARTNER and JV-NAME parameters

When multiple robot archives are supported, the `PARTNER` parameter and, if the “Job Variables” product is used (see the “JV” manual [7]), the `JV-NAME` parameter must be unambiguous in all start files.

UCONID, UCONPWD, OPERID, OPEROLE and OPIDPWD parameters

See the explanations in [section “ROBAR-CL as an authorized user program” on page 191](#).

AUTO-REPLY parameter

The value `-ar` of the parameter `AUTO-REPLY` allows ROBAR to answer its own PAUSE messages (autoreply). In this case, it is absolutely necessary that the `CONSLOG` file be checked for any potential ROBAR problems.

MARENLNK and MARENREP parameters

The initialization of these parameters (`*NONE`) may not be changed. ROBAR-CL always selects (e.g. to update the MAREN catalog) the highest installed MAREN version unless systems support has specified something different by means of the `SELECT-PRODUCT=VERSION` command.

DUMP parameter

If the parameter `DUMP=YES`, a dump is created (as in dialog mode) if ROBAR-CL-DCAM terminates abnormally. Otherwise ROBAR-CL-DCAM quits with an error code.

LANGUAGE parameter

The language for the messages output in BS2000/OSD is defined in the ROBAR start file `SYS-PRC.ROBAR-CL.<ver>`. Depending on the language selection, either `SYS-PRC.ROBAR-CL.<ver>.TEXT.D` (German) or `SYS-PRC.ROBAR-CL.<ver>.TEXT.E` (English) is used.

6.2.2 ROBAR-CL as an authorized user program

ROBAR-CL is a BCAM/DCAM application which connects itself to \$CONSOLE when it starts and then identifies itself to the operating system as an authorized user program. The application then executes operator functions in accordance with the routing codes assigned to it and thus functions as a logical console.

Further information on authorized user programs is provided in the “Introduction to System Administration” [2].

You can use static or dynamic authorization names for ROBAR-CL. Assign at least the routing codes *, T, E, N, G, U and A to the application.

Static authorization name

A static authorization name (e.g. CON1) is defined in the startup parameter service, parameter set OPR. Normally its routing codes are also assigned to it at the same time. The authorization name must be unique and cannot be used by any other application. The operating system must be restarted when a newly defined authorization name is to be used.

Supply the following parameters with values in the ROBAR-CL start file:

UCONID	Static authorization name (default value: CON1)
UCONPWD	Password for UCONID

The OPEROLE, OPERID and OPIDPWD parameters can contain any values. They are not evaluated.

Dynamic authorization name

You can use any operator identification (operator ID) and operator role for ROBAR-CL. The operator ID requires operator authorization. Assign at least the routing codes *, T, E, N, G, U and A to the operator role.

Supply the following parameters with values in the ROBAR-CL start file:

UCONID	*NONE
UCONPWD	*NONE (the parameter has no meaning in this case)
OPERID	Operator ID (default value: TSOS)
OPEROLE	Operator role which is requested for the operator ID (default value: SYSADM)
OPIDPWD	Password for the operator ID (default value: *NONE)

The dynamic authorization name (@001 through @192) is assigned and managed by the operating system when the application is started.

If ROBAR-CL is not assigned the operator role when the application starts (message NBR0984), it terminates and SYSOUT message ROB2226 is issued.

If an incorrect OPIDPWD password is entered when the application starts, ROBAR-CL terminates and SYSOUT message ROB2225 (NBR0717 on the console) is issued.



You are recommended to call the ROBAR-CL start procedure via a procedure which requires hidden entry of the OPIDPWD password, e.g.:

```
/DECLARE-PARAMETER NAME=PASS(INIT=*PROMPT -
/(PROMPT-STRING='OPID-PASS: ',DEFAULT-VALUE=*NONE,SECRET-INPUT=*YES))
...
/ENTER-PROC $SYSMAREN.SYSPRC.ROBAR-CL.<ver>, -
/PROC-PAR=(...,OPIDPWD=&PASS)
```

6.3 Connection of ROBAR-CL, ROBAR-SV, and the archive system

Installation of the required connections and configuration of the archive systems are not dependent on the ROBAR software being installed. Perform these activities before ROBAR-SV is configured.

6.3.1 Connection from the BS2000 system to the ROBAR server

All BS2000 systems which are to participate in ROBAR operation require a connection to ROBAR-SV on the ROBAR server.

You can implement the physical connection from the BS2000 system to the ROBAR server in various ways:

- via LAN (TCP/IP protocol) with ZASLAN
- via WAN with a front-end processor

You make the names and the connection-specific parameters known via the Transport Name Service of the CMX on the ROBAR server (see [section “Generation of names for CMX” on page 238](#)).

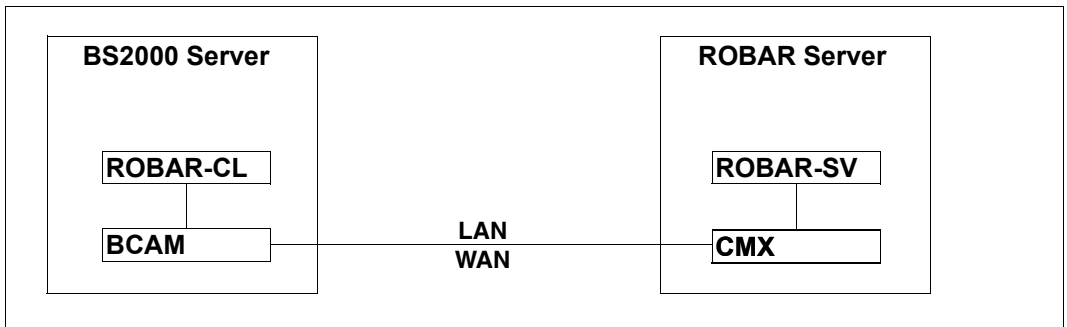

Figure 18: Connection of ROBAR-CL and ROBAR-SV



Recommendations for SE servers:

- When ROBAR-CL and the ROBAR server are located on systems of the same SE server, it is recommended that the SE server's MCNPR network be used for the connection. The SENET host name of the relevant BS2000 host should be entered in the CMX configuration as the IP address.
- When ROBAR-CL on a system of the SE server is to be connected to an external ROBAR server, it is recommended that the connection be established over the SE server's MANPU network.

6.3.2 Connection from the ROBAR server to the archive system

The ROBAR server and the archive systems must be connected. You may need to specify settings for working with ROBAR in the archive systems.

Firewall monitoring

If the connection between the ROBAR server and the archive system goes through a firewall, you should exclude this connection from the firewall's "sign-of-life monitoring".

MTC processing is not a regular operation but is controlled by events. If no data exchange takes place between the ROBAR server and the archive system during the monitoring period configured in the firewall, this can lead to a disruption of the connection which cannot be detected by ROBAR-SV and the archive system. Jobs are then not processed.

6.3.2.1 Connections at the SCSI interface

At the SCSI interface, connections between the ROBAR server and the archive systems require both a hardware installation (Host Bus Adapter (HBA)) and a software installation (`lpfc` driver) on the ROBAR server, see [page 195](#).

The BS2000 systems, the ROBAR server and the archive systems with a SCSI interface are connected to each other via an Enterprise Storage System (Storage Area Network, SAN). In the case of connections of the type "fabric", dedicated connections are established between the servers and the archive systems. The servers and archive systems form domains which are assigned to each other via FC switches ("zoning").

The hardware connections consist of

- FC connections from the BS2000 systems to the SAN (data transfer),
- an FC connection between the Host Bus Adapter (HBA) on the ROBAR server to the SAN (control of the robotics),
- FC connections from the SAN to the devices of the Scalar i500 archive system or to the I/O blade of the Scalar i2000 and i6000 archive systems.



LTO-6 devices are always connected directly, not via the I/O blade.

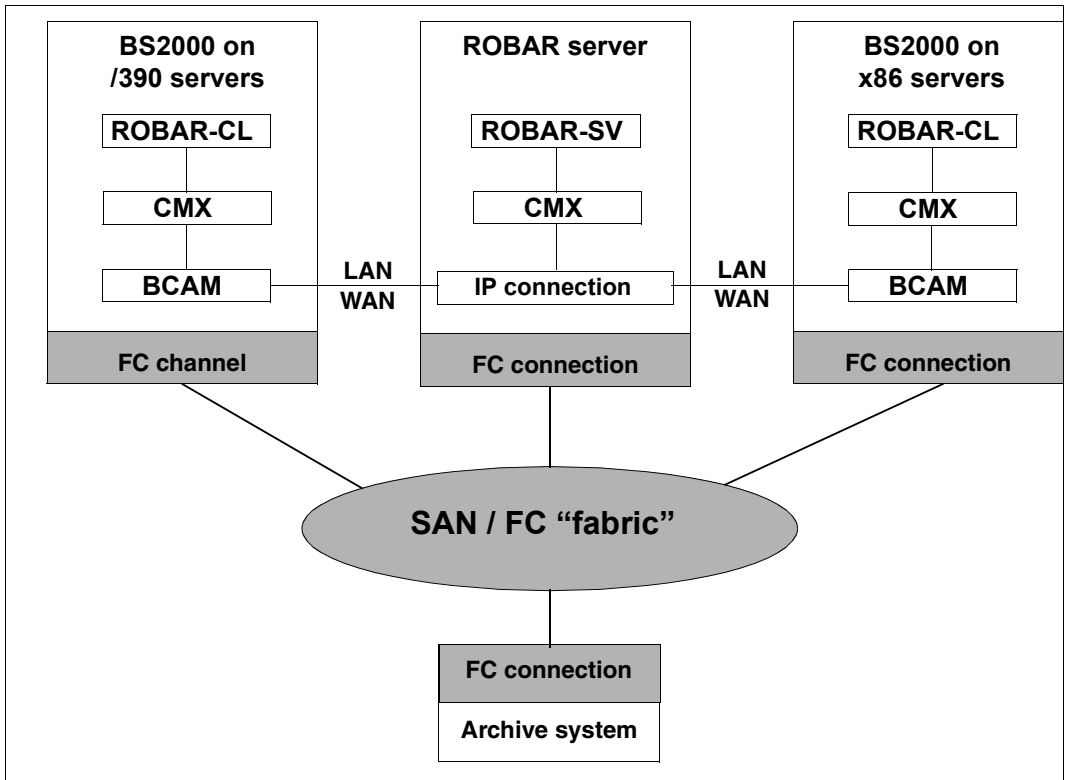

Figure 19: Connections at the SCSI interface

Information on system generation of a SAN is provided in the “System Installation” manual [4]. You can check the installation of a SAN using the SANCHECK utility routine, see the “Utility Routines” manual [5].

Installation and configuration on the ROBAR server

Systems support must install the controller hardware, the “Host Bus Adapter” (HBA), on the ROBAR server. Before the HBA is installed, the `lpfc` driver must be installed (without a reboot).

After the `lpfc` driver has been installed, the Linux operating system automatically configures the `lpfc` driver when the ROBAR server is rebooted. When this reboot takes place, the SAN connection of the ROBAR server with the archive systems which are to be controlled (“zoning”) must be available and the archive systems must be operating.



The section “Device special file” below provides an explanation and describes the situation in ROBAR-SV before V6.5. For ROBAR V6.5 and higher you are recommended to use persistent device nodes, see the relevant section on [page 196](#).

Device Special File

The result of the reboot is a “device special file” `/dev/sg<n>` (`<n>=1,2,...`) for each archive system. You can find the associated directory using the YaST hardware information or, if available, using the command `sg_inq /dev/sg<n>`. Here the value 8 must be contained under `Device_type` in the output, and the entry `medium changer` under `Peripheral device type`.

By default this file has attributes which only grant access to the `root` user ID.

The file mentioned above with the name `/dev/sg<n>`, `/dev/sg3` for example, is an important value in the ROBAR-SV configuration file for SCSI interface. Enter this file name in the `robot_address1` parameter when ROBAR-SV is configured, see [page 215](#).



After extending or changing the SAN connections (“zoning”) the assignment of the files `/dev/sg<n>` can also change.

Persistent device nodes

To get round the problem of the changing device special files, in ROBAR what are known as persistent device nodes can be configured for archive systems.

To do this, when configuring ROBAR-SV enter the `/dev/rob/<library_device_address>` file name in the configuration parameter `robot_address1` (see [page 215](#)). `/dev/rob/<library_device_address>` can be the following:

- fully qualified file name of the “device special file” (e.g. `/dev/sg3`)
- fully qualified file name of the persistent device node resp. serial number of the archive system concerned or of a partition of it (e.g. `/dev/rob/1ADIC_203100195_LL5`)

When the ROBAR server is rebooted, ROBAR-SV and the Linux subsystem `udev` use a symbolic link to ensure that the persistent device node is always assigned to the right device special file. As a result, the configuration files are not affected by changes in the SAN connections.

6.3.2.2 Configuring archive systems with a SCSI interface

ROBAR-SV requires that all actions for devices and cartridges should be initiated and controlled exclusively by ROBAR. Parallel actions by other instances, e.g. by the archive system itself, are not permitted.

Consequently specify settings in the Scalar i500, i2000 and i6000 archive systems for the use of ROBAR via their service interface.

Settings in the archive systems

Make the settings required to define a partition, including LUN mapping, in the archive systems.

Among other things, enter the WWPN of the HBA on the ROBAR server in the Scalar i2000 and i6000 archive systems. In this way the HBA obtains the right to access this partition.

Operating mode of the UNLOAD

Disable automatic unloading of a cartridge in the archive systems.

Scalar i500

Disable the UNLOAD wizard in the `Tools – System Settings` menu (no check mark).

Scalar i2000 and i6000

Set the following in the `Setup` menu: `Physical Library: Automatic Drive Unload:`
Disable

6.3.2.3 Connections at the ABBA interface

You may enter the IP address of the archive system in the `/etc/hosts` file to address the archive system with its hostname (if your system does not have DNS support or if you wish to make another setting).

6.3.2.4 Configuring archive systems with an ABBA interface

ROBAR-SV requires that all actions for devices and cartridges should be initiated and controlled exclusively by ROBAR. Parallel actions by other instances, e.g. by the archive system itself, are not permitted.

6.4 Installing ROBAR-SV

ROBAR-SV is installed on the ROBAR server and runs there under the Linux operating system. Other software products which are independent of ROBAR can also run on the ROBAR server.



ROBAR-SV should not run on a server on which real-time software is installed or which exhibits high levels of utilization.

When upgrading from an earlier ROBAR version, please note the [“Notes for ROBAR-SV V6.0 and earlier” on page 244](#).

ROBAR-SV is supplied on the so-called “ROBAR CD” as an add-on pack and is installed with YaST (YaST: Yet another Setup Tool). ROBAR-SV has a predefined directory structure. This is described in the Release Notice for ROBAR-SV.

Configuration of ROBAR-SV is described in the [section “Configuring ROBAR-SV” on page 209](#).



You only need to install ROBAR-SV **once** on the ROBAR server. ROBAR-SV can manage multiple archives (storage locations) using different ROBAR-SV instances, see [page 59](#).

The add-on pack ROBAR is installed on SE servers (see [page 104](#)) together with the SE Manager.

Prerequisites

The software product `apache2` must be installed and started before the installation of ROBAR-SV takes place. It is required for the installation of the RPM package `robar_ui` (Web access to the ROBAR server). See also the Release Notice for ROBAR-SV.

Resources

In the Linux system, you can set limit values for the use of resources using the `ulimit` command. The default settings of the Linux system are normally sufficient for ROBAR operation.

When ETERNUS CS systems are used, take note of the configuration specifications and technical information in the ETERNUS CS Release Notice.



When ROBAR-SV trace files are generated (see [page 50](#)), large volumes of data may be compiled.

6.4.1 Installation using YaST

Insert the "ROBAR CD" in the CD drive if you wish to install from the CD. Or make the ISO image of the "ROBAR CD" available if you wish to install from the ISO image.

- ▶ Start YaST Control Center (as "superuser")
- ▶ In the *Software* area of the overview mask click on *Add-On Products*
- ▶ In the follow-up mask *Installed Add-On Products* click on *Add*
- ▶ In the follow-up mask *Media Type* select the input medium:
 - ▶ Select *CD* if you wish to install from CD. Confirm with *NEXT*
 - ▶ For a SLES11 operating system select *Local ISO Image* if you wish to install from the ISO image and confirm with *NEXT*. In the follow-up mask enter the directory path to the ISO image. Confirm with *NEXT*
- ▶ Confirm the *Insert the add-on product CD* request with *Continue*
- ▶ In the follow-up mask *License Agreement* confirm the license conditions and click on *NEXT*

- ▶ Highlight *Robar Server* in the *Archive Software* directory of the follow-up mask *Software Selection and System Tasks* and confirm with *Accept*

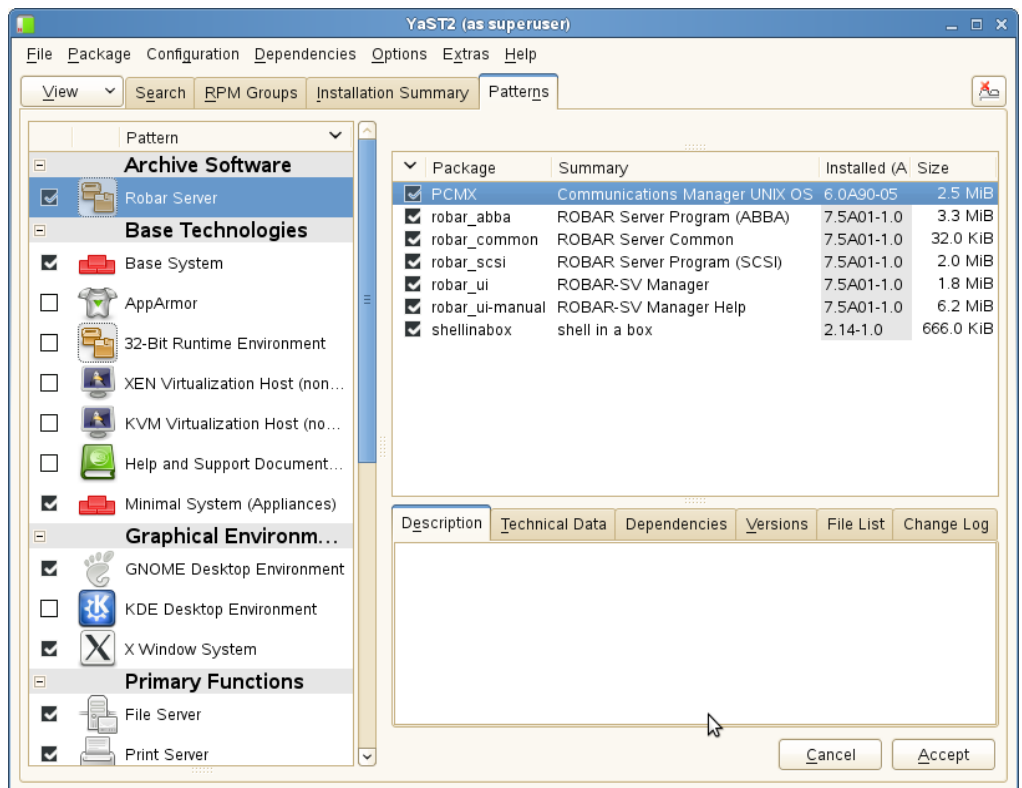

- Installation is performed. The progress is displayed in the follow-up mask *Perform Installation*. After installation has been completed, click on *NEXT*.

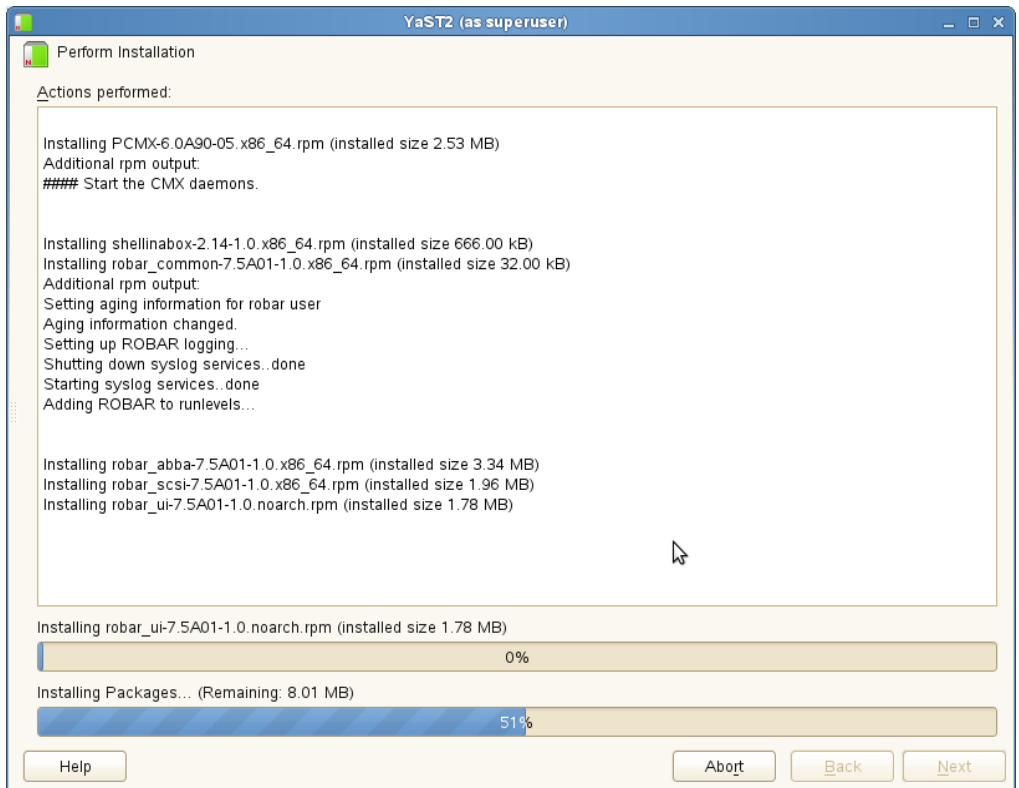

The masks of YaST contain the customary buttons *Help* for the help function, *Abort/Cancel* to terminate the function, and *Back* to return to the preceding mask.

6.4.2 Directories and files of ROBAR-SV

In the Linux file system the following directories and files are created when ROBAR-SV is installed and configured:

- Programs, scripts and binary files in the `/usr/bin` directory/

<code>robar</code>	<code>robar</code> menu program, see page 148
<code>robar_start</code>	Program for starting ROBAR-SV, see page 42
<code>robar_stop</code>	Program for stopping ROBAR-SV, see page 44
<code>RECOVER_DISK_FULL</code>	Script for disk monitoring, see page 54
<code>BACKUP_ROBAR_CONF</code>	Script for backing up the ROBAR configuration files, see page 61
<code>RESTORE_ROBAR_CONF</code>	Script for restoring the ROBAR configuration files, see page 61

Scripts for the SCSI interface:

<code>COLLECT_DIAG_DATA_SCSI</code>	Automatic creation of diagnostic documentation, see page 328
<code>SET_DIAG_TRACE_SCSI</code>	Activate trace, see page 50
<code>SET_RESTART_OPTION_SCSI</code>	Enable or disable automatic restart, see page 46

Scripts for the ABBA interface:

<code>COLLECT_DIAG_DATA_ABBA</code>	Automatic creation of diagnostic documentation, see page 328
<code>SET_DIAG_TRACE_ABBA</code>	Activate trace, see page 50
<code>SET_RESTART_OPTION_ABBA</code>	Enable or disable automatic restart, see page 46

- Configuration files in the `/etc/` directory

<code>robar.conf</code>	Global configuration file for ROBAR-SV, see page 210
<code>robar/scsi.conf.d/<instance></code>	Configuration files of the created ROBAR-SV instances (SCSI interface), see page 212
<code>robar/scsi.conf.d/templates/template.txt</code>	Sample configuration file for the SCSI interface, see page 215
<code>robar/abba.conf.d/<instance></code>	Configuration files of the created ROBAR-SV instances (ABBA interface), see page 212
<code>robar/abba.conf.d/templates/template.txt</code>	Sample configuration file for the ABBA interface, see page 227

- Links to the current version in the `/opt/fujitsu/robar/` directory (when a problem occurs, these links can also be set to the corresponding directories of a different ROBAR version)

`scsi ->` Link for the SCSI interface

`/opt/fujitsu/robar/<ver>/scsi/`

`abba ->` Link for the ABBA interface

`/opt/fujitsu/robar/<ver>/abba/`

`common ->` Link for general data

`/opt/fujitsu/robar/<ver>/common/`

- General, version-specific files in the `/opt/fujitsu/robar/<ver>/common/` directory
- General ROBAR-SV error logging file `robar.log` in the `/var/log/` directory (see [page 53](#))
- Sample of the SCSI interface in the `/opt/fujitsu/robar/<ver>/scsi/` directory

`new_instance/clean` Files for cleaning cartridges

`new_instance/cmx` Job files

`new_instance/error_history` Files containing information on device and volume errors that occurred

`new_instance/list` Print files

`new_instance/param` CMX parameter files

`new_instance/pipe` Files for named pipes

`new_instance/message_storage/scsi_1` Original ROBAR rule files for the SCSI interface

`new_instance/trace` Trace files

`new_instance/tsn` TSN file of the BS2000 jobs

`nls/de/ROBAR-SV.cat` ROBAR message catalog (German)

`nls/en/ROBAR-SV.cat` ROBAR message catalog (English)

`nls/C/ROBAR-SV.cat` ROBAR message catalog (English)

- Sample of the ABBA interface in the `/opt/fujitsu/robar/<ver>/abba/` directory

<code>new_instance/clean</code>	Files for cleaning cartridges
<code>new_instance/cmx</code>	Job files
<code>new_instance/error_history</code>	Files with information on current device and volume errors
<code>new_instance/foreign</code>	Files for foreign cartridges
<code>new_instance/freepool</code>	Freepool files
<code>new_instance/list</code>	Print files
<code>new_instance/param</code>	CMX parameter files
<code>new_instance/pipe</code>	Files for named pipes
<code>new_instance/ message_storage/CentricStor</code>	Shipped ROBAR rule files for ETERNUS CS
<code>new_instance/trace</code>	Trace files
<code>new_instance/tsn</code>	TSN file of the BS2000 jobs
<code>nls/de/ROBAR-SV.cat</code>	ROBAR message catalog (German)
<code>nls/en/ROBAR-SV.cat</code>	ROBAR message catalog (English)
<code>nls/C/ROBAR-SV.cat</code>	ROBAR message catalog (English)

Shell variable PATH

When the shell variable `PATH` contains the value `/usr/bin/`, the programs, scripts and binary files of ROBAR-SV can be called from any directory.

Message catalogs

ROBAR-SV uses one of the above message catalogs, depending on the language. The language in the Linux system is determined by the shell variable `LANG`.

Runtime files for a ROBAR-SV instance

When a ROBAR-SV instance is started, its runtime files are created in the `/var/lib/<interface>/<instance>/...` directory.

This directory is supplied with the current files for the ROBAR-SV instance from the sample directory of the corresponding interface (`/opt/fujitsu/robar/<ver>/<interface>/new_instance/...`).

The interface-specific configuration file of the ROBAR-SV instance (`/etc/robar/<interface>/<instance>`) is also transferred and automatically converted to a binary format.

Each different ROBAR-SV instance consequently has its own runtime environment.



Modifications to the interface-specific configuration file of the ROBAR-SV instance after it has started have no effect.

6.4.3 Uninstallation

1. Start YaST (as “superuser”)
2. In the *Software* area of the overview mask click on *Software Management*
3. In the follow-up mask click on the *Patterns* tab.
4. Click on the *ROBAR Server* pattern. The installed RPM packages are displayed in the right-hand column.
5. Right-click on *PCMX* and select *Delete*

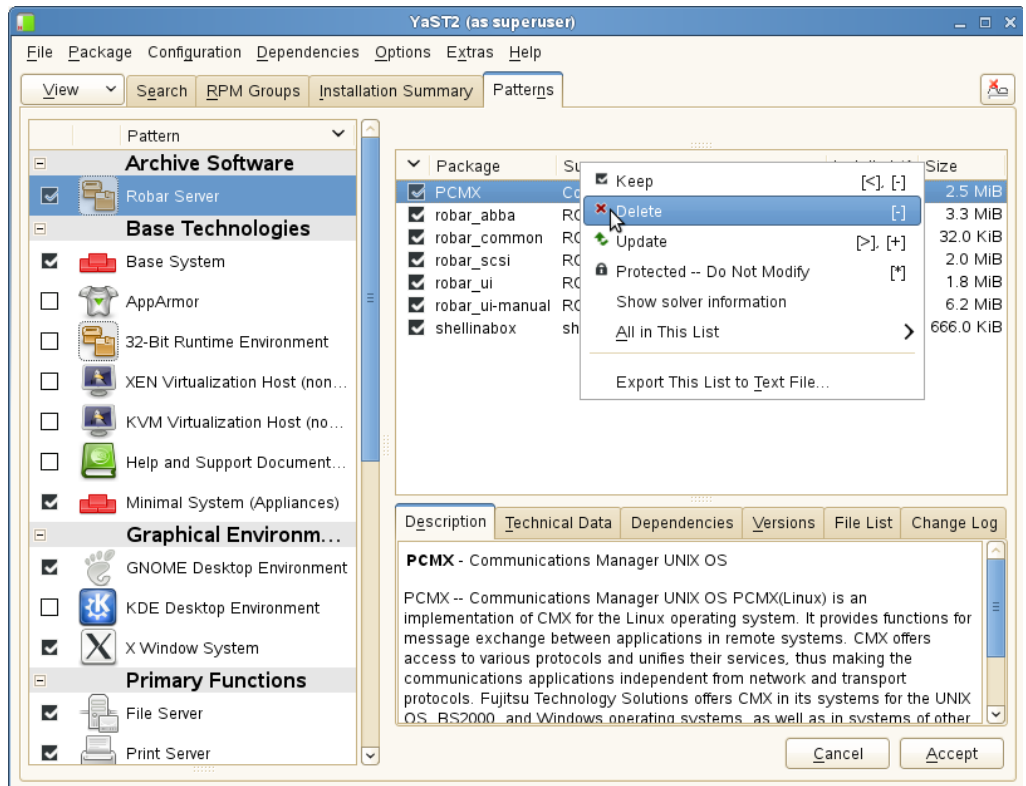

6. A warning will be issued. Select the relevant action and confirm with *OK -- Try Again*

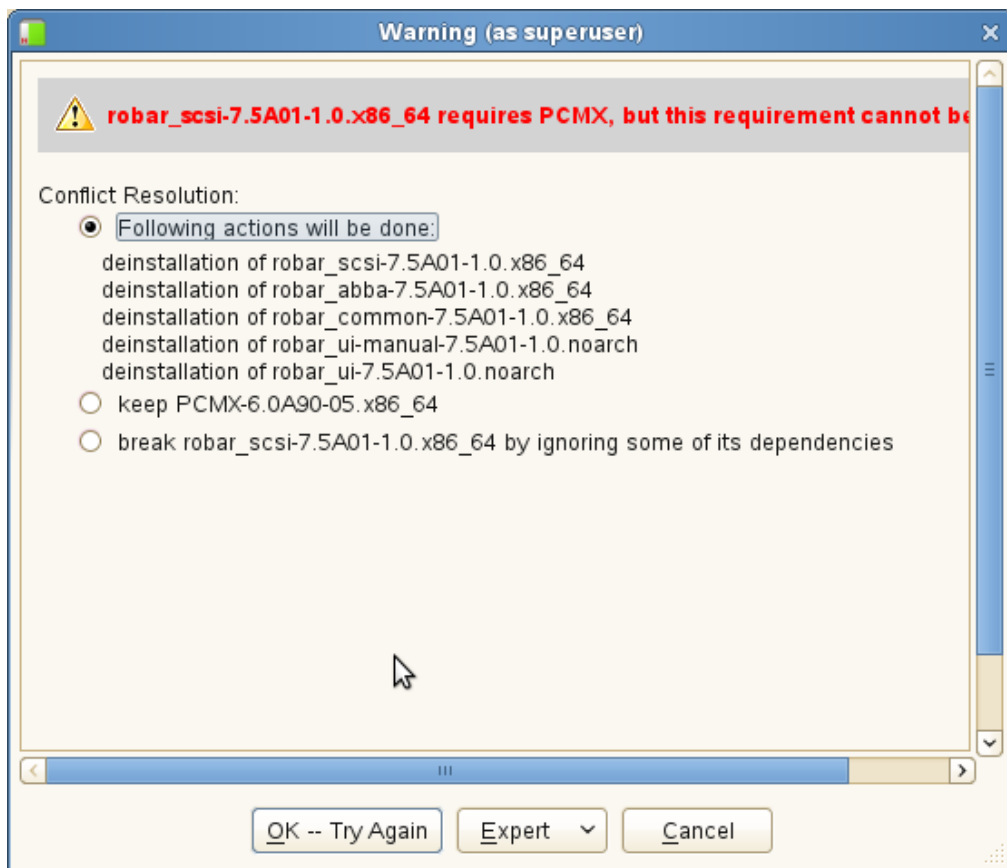

You are returned to the previous mask. The components which have been selected for uninstillation are now flagged with a red cross.

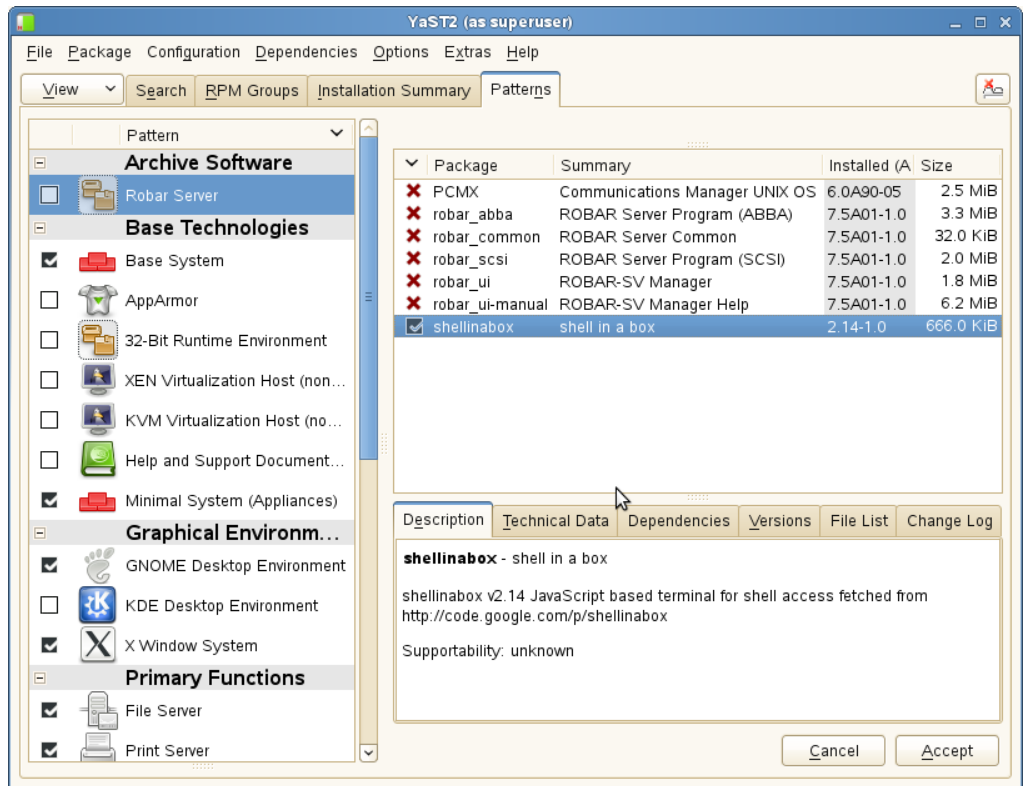
7. Right-click on *shellinabox* and select *Delete*8. Confirm uninstallation with *Accept*

6.5 Configuring ROBAR-SV

ROBAR-SV uses ROBAR-SV-specific configuration parameters for runtime control. You specify the settings for these in the global configuration file of ROBAR-SV and for each ROBAR-SV instance in the interface-specific configuration files. How the configuration parameters are set and other activities for configuring ROBAR-SV are described in this section.

6.5.1 Users of ROBAR-SV

The user groups `robaradm` and `robarsv` and the user `robar` are configured when ROBAR-SV is installed. The user `robar` is a member of the user group `robarsv`.

The Linux system administrator can assign further suitable local users or LDAP users to these user groups in order to manage ROBAR-SV. A user can also be assigned to both user groups.

Following installation the user group `robarsv` has all access rights to the files of ROBAR-SV, but only read-only authorization for the ROBAR-SV configuration files in the `/etc/robar/<interface>.conf.d` directory.

The user group `robaradm` has all access rights to the ROBAR-SV configuration files in the `/etc/robar/<interface>.conf.d` directory, but only read-only authorization for the other files of ROBAR-SV.

Other readers can only access the files of ROBAR-SV in read mode.

See also the [section “Roles, users and user groups of ROBAR-SV”](#) on page 39.

6.5.2 Global configuration file for ROBAR-SV

The global configuration file `/etc/robar.conf` of ROBAR-SV contains the configuration parameters which are important for executing all ROBAR-SV instances. It is created when ROBAR-SV is installed and is provided with the default values. It must be adjusted after the current configuration has been installed in the data center.

The ROBAR-SV Manager offers user-friendly functions to edit the global configuration file with the ROBAR editor, see section [“Editing the global configuration file of the ROBAR server” on page 141](#).

Sample global configuration file of ROBAR-SV

Information on the global configuration file

ROBAR_EDITOR configuration parameter

Defines the editor that is called in the `DEFINES` and `FREEPOOL` menus of ROBAR.

Default value: `/usr/bin/vi`

ROBAR_PRINT configuration parameter

All printer outputs are produced using the `lpr` command defined in this variable. It is also possible to specify a print procedure.

Default value: `/usr/bin/lp`

min_disk_space configuration parameter

Manages the disk space controlling.

The following specifications can be made:

`<absolute_value>`

Minimum available free disk space in bytes
(permissible value range: 1000000 ... 2147483647)

`<relative_value>`

Minimum available free disk space in percent
(permissible value range: 1% ... 99%).

When this configuration parameter is 0 or 0%, the available free storage space is not monitored. Default value when the configuration parameter is not specified: 1000000.

max_trace_file_age configuration parameter

Controls the deletion of old trace files. The following specification can be made:

<absolute_value>

Number of days (permissible value range: 0 ... 100000)

Files which are older than the value <current_date> - max_trace_file_age are deleted. The check takes place each day and when the ROBAR-SV instance is started.

When this configuration parameter is 0, the age of the trace files is not monitored.

In SE server installations max_trace_file_age=30 is set by default. Otherwise the default value is 0.

ROBAR_BACKUP_DIR configuration parameter

Defines the directory into which the compressed tar files are to be shifted when the command RECOVER_DISK_FULL is executed (see [page 55](#)).

Default value: /var/opt/fujitsu/robar

ROBAR_SAVE_DIR configuration parameter

ROBAR_SAVE_DIR defines the place to which the diagnostic data should be saved by the SAVE function and by the COLLECT_DIAG_DATA_SCSI and COLLECT_DIAG_DATA_ABBA scripts. If the configuration parameter is not defined, the diagnostic data is saved to the /var/opt/fujitsu/robar directory.

ABBA, SCSI configuration parameter

Defines the ROBAR-SV instances which are to be started automatically, e.g.

SCSI="scsi_instance1,scsi_instance2,scsi_instance3".

By default no ROBAR-SV instances are started automatically.

ROBAR-SV instances configured in this way are started by the Linux system if the latter has reached a specific "run level". When the Linux system is shut down, these ROBAR-SV instances are automatically stopped.

6.5.3 Interface-specific ROBAR-SV configuration files

The interface-specific configuration files for the ROBAR-SV instances contain configuration parameters which are important for the individual execution of a ROBAR-SV instance. They contain not only general data, but also the MTC devices to be managed by the ROBAR-SV instance, the BS2000 systems and their TSN names, and the storage location name of the archive.

Sample configuration files (editable text files) belong to the ROBAR-SV delivery package. They are contained in the interface-specific directories `/etc/robar/<interface>.conf.d/templates` and have the file name `template.txt` (with English and German comments).

After ROBAR-SV has been installed, create a separate interface-specific configuration file for each required ROBAR-SV instance (see [page 212](#)).



The name of the ROBAR-SV instance's interface-specific configuration file is identical to the name of the ROBAR-SV instance.

See also [section "Information on adjusting the interface-specific configuration file" on page 214](#).

When the ROBAR-SV instance starts, the interface-specific configuration file is interpreted, checked for semantic consistency, and automatically converted to a binary format. When the ROBAR-SV instance is started via the ROBAR-SV Manager, warning messages and errors are displayed in a dialog. They are displayed in the footer of the menu window when the ROBAR-SV instance is started in the `robar` menu program. They are output to `STDERR` when the ROBAR-SV instance is started from the console.

ROBAR-SV instances can also be predefined in the global configuration file of ROBAR-SV. They are then started automatically, see [page 211](#).

6.5.3.1 Creating a new configuration file for a ROBAR-SV instance

For this purpose the ROBAR-SV Manager offers a user-friendly wizard with which you can create a new ROBAR-SV instance either completely from scratch or by modifying an existing configuration file. You are recommended to proceed as follows:

- ▶ Start the ROBAR-SV Manager.
- ▶ In the `ROBAR-SV Instances` menu select the `Upload configuration file` button if you wish to upload a configuration file for the new instance from your PC to the ROBAR system.
- ▶ In the `ROBAR-SV Instances` menu select the `Create new instance` button. The wizard for creating a new instance is started.
- ▶ In the first step choose whether you want to create a ROBAR-SV instance either completely from scratch or on the basis of an uploaded configuration file.

- ▶ In the following steps enter the information required for the new instance. Using your information the wizard will create the interface-specific configuration file with the name of the ROBAR-SV instance.

Each additional ROBAR-SV instance requires its own interface-specific configuration file.

You can, as previously, also assign the configuration file manually:

1. As ROBAR administrator copy one of the sample configuration files of ROBAR-SV (`/etc/robar/<interface>.conf.d/templates/template.txt`) to a new file in the `/etc/robar/<interface>.conf.d/` directory. The file name of the new file must correspond to the name of the ROBAR-SV instance (e.g. `scsi_instance1`).
2. Adjust the new file to the current configuration of the ROBAR-SV instance. See [section “Information on adjusting the interface-specific configuration file” on page 214](#).

6.5.3.2 Migrating an existing configuration file

If the editable or binary configuration file of the previous ROBAR version is still available to you, you can use this as the new interface-specific (sample) configuration file following conversion. See also [page 244](#).



A configuration file of ROBAR V6.5 or higher does **not** need to be migrated. It is sufficient to set the `original_version=V7.5` parameter (section `Global definitions`).

Use the ROBAR-SV Manager to execute the migration:

- ▶ Start the ROBAR-SV Manager.
- ▶ In the `ROBAR-SV Instances` menu select the `Upload configuration file` button if you wish to upload a configuration file of the preceding version from your PC to the ROBAR system and automatically migrate it.

The wizard for creating a new instance enables you to use the migrated configuration file as a basis for the new instance, see [page 212](#).



If the uploaded configuration file comes from a ROBAR version V6.0 or earlier, parameters which are no longer supported in newer ROBAR versions cannot be converted. In addition, parameters which have been introduced since ROBAR V6.5 are missing in these configuration files.

6.5.3.3 Information on adjusting the interface-specific configuration file

The following must be borne in mind when adjusting the content of an interface-specific configuration file for a ROBAR-SV instance:

- The length of the file name is limited to 15 characters and corresponds to the name of the ROBAR-SV instance, e.g. `scsi_instance1`.
Alphanumeric characters and the characters `_` (underscore), `.` (period) and `@` (commercial at) may be used in the file name.
- Spaces are permitted in the file, however not as the first character in a line
- Comment lines are permitted; they contain the hash character (`#`) in the first column.
- The information sections must be specified in a defined order. The following order must be adhered to:
`Internal environment variables, Global definitions, Host definitions, Device definitions, MAREN host definitions, Host VSN definitions`
- All operands in the `Internal environment variables` and `Global definitions` sections must be in a separate line
- Each of the remaining sections must contain a line for each BS2000 system (host), each device or each server name
- In the `Host definitions, Device definitions, MAREN host definitions, Host VSN definitions` sections, the first operand must be a BS2000 system (host), a device or a server name. The subsequent operands (except `Host VSN definitions`) are keyword operands. The keyword operands and the associated value must be separated by an equals sign. Spaces are permitted before and after the equals sign.
- A number of operands in one line (not permitted in the `Global definitions` section) are separated by one or more spaces
- If an operand occurs more than once in one line (not permitted in the `Global definitions` section), only the last is evaluated
- Keyword operands can be specified in any order
- The syntax of the `type` operand in the `Devices definitions` section is not checked
- Only a syntactic check is performed in the `Host definitions` section. The accuracy of the TNS names is not checked
- For newly created configuration files, the `original_version` field must be assigned the current ROBAR version.
- Only the first 10 BS2000 systems are taken into account in the `MAREN host definitions` section. An appropriate message is output if more than 10 BS2000 systems are specified

- The number of requests to be executed simultaneously by one robot is specified using `multi_processing_level`. The minimum value that can be defined is one request, the maximum is ten requests.
- Note the information in the [section “Working with multiple archives” on page 59](#) when working with more than one archive system.

6.5.3.4 Sample of the interface-specific configuration file (SCSI interface)

The sample configuration file `/etc/robar/scsi.conf.d/templates/template.txt` below is supplied for the SCSI interface.

The file contains notes in English and German. Only the English comments are shown in this manual.

The notes on the various sections of the file are contained at the end of the section concerned; they are arranged according to the order of their occurrence.

```
# This file is an example of an editable configuration file for
# ROBAR-SV 7.5A for SCSI-Interface.
# It serves as a template to create real configurations for the tape
# library system models 'i' (e.g. i2000).
#
# As for the handling of configuration files, please refer to the section
# "Configuring ROBAR-SV" in the ROBAR manual,
#
# The following shortcuts are used in this context:
# <text_m..n> : string of characters; m, n are integers and m..n defines
#               the minimal and maximal fieldwidth.
# <instance_number_(l|m|..|n)> : the available values are enumerated from l up
#                               to n. l, m, n can be integers, strings, $, #, @.
# Notice : it is an error to define parameters not supported with values!
#         Each parameter must always have a value.
#         All string identifiers are case sensitive.

# Internal environment variables
#
# gen_env_vars
# CLOSE_DISPLAY=YES|NO
#         If CLOSE_DISPLAY=YES, open DISPLAY and MANUAL menus are closed when
#         ROBAR-SV is started.
# LTRACE=YES|NO
# ROBAR_TRACE=YES|NO
```

```

# SERVER_TRACE=YES|NO
#       The LTRACE, ROBAR_TRACE and SERVER_TRACE variables are used
#       internally and are therefore not described here.
# MANCHECK=YES|NO
#       Input parameter check in commands of the menu MANUAL
# ROB_STAT_NOTIF=TYPE|PAUSE
#       If this variable is defined, a TYPE or a PAUSE message
#       is output depending on the setting.
# ROBAR_ARCHIV=<vs_n_list>
#       Archive numbers (VSNs) which may be processed by this
#       ROBAR-SV instance.
# ROBAR_INFO_MSG=YES|NO
#       Specifies whether ROBNxxx messages are to be output
#       to the BS2000 console
# ROBOT_OFF_MSG=TYPE|PAUSE
#       If the robot switches to OFF mode, the message sent to
#       the BS2000 system is a TYPE or a PAUSE message.
# INIT_RESTART_OPTION=YES|NO
#       Sets the initial value of automatic instance restart during
#       the first start of DEFINED instance.
#       This can be dynamically changed afterwards with
#       SET_RESTART_OPTION_SCSI command or by the web application.
# end_env_vars
#
# The next line is a specially formatted comment to display optionally
# additional user info in ROBAR-SV Manager.
# It has to begin with #%INFO%= without blank characters before it.
# Max. up to 80 characters after "=" can be displayed.
# Example:
#%INFO%= Scalar

gen_env_vars
CLOSE_DISPLAY=NO
LTRACE=NO
ROBAR_TRACE=NO
SERVER_TRACE=NO
MANCHECK=NO
#ROB_STAT_NOTIF=
#ROBAR_ARCHIV=volna1-volna8,volna1,volnam
ROBAR_INFO_MSG=NO
ROBOT_OFF_MSG=PAUSE
INIT_RESTART_OPTION=NO
end_env_vars

```

Notes on the section Internal environment variables (SCSI interface)

Information field %INFO%

Additional archive system information. In the ROBAR-SV Manager this is displayed in the archive system's status information.

CLOSE_DISPLAY configuration parameter

The MANUAL and/or DISPLAY menus can remain open during the ROBAR start procedure. If the relevant ROBAR server indicates a low level of performance, a data bottleneck may have occurred between the ROBAR processes and the display processes that leads to a timeout during initialization of the start procedure. If the CLOSE_DISPLAY shell variable is defined and the variable value is set to YES, the two accessed menus are closed automatically during the ROBAR-SV start procedure. Default value: CLOSE_DISPLAY=NO

MANCHECK configuration parameter

MANCHECK allows you to restrict the range of volumes that can be processed using the menu MANUAL. In a multisystem configuration, for instance, you can stop foreign volumes from being processed using the MANUAL menu (access protection for foreign volumes).

If MANCHECK=YES, then the commands entered via the menu MANUAL are subject to the same checks as the commands from a BS2000 system. All parameters contained in the command are checked for plausibility and reliability.

The following checks are carried out:

- VSN specifications are compared with the configuration parameter ROBAR_ARCHIV. If the configuration parameter is present and has been supplied with values, the VSN specifications of all commands are compared with the values in the configuration parameter.
- If the check was positive, the values contained in the Host VSN definitions section of the configuration file may also be included in the check.

If MANCHECK=NO, the commands from the menu MANUAL are not checked.

The section Host VSN definitions in the configuration file must contain a server with the host name MAN and with a VSN list for this function to be available.

If the configuration file does not contain a host called MAN, the following error message is issued: RSV1332 HOST NOT AUTH. HOST: MAN.

Default value: MANCHECK=NO

ROBAR_ARCHIV configuration parameter

ROBAR_ARCHIV shows the archive numbers (VSNs) which may be processed by this ROBAR-SV instance. If this variable is not set, all VSNs are accepted for processing. In entries made during installation, lowercase letters are automatically converted into uppercase. Maximum length: 1024 characters.

Note the following guidelines for entering VSNs:

- The VSN consists of six of the following characters: A..Z, a..z, 0..9, \$, @, #, * (but only in *FRxxx and *CLxxx).
- when specifying VSN ranges (e.g. ARCHxx–ARCHyy), xx and yy must be numbers. The letters in the number range must correspond as they are used to define the start and end of the number range.
- The first VSN may not be greater than the last VSN.
- The first and last VSNs in the VSN range are separated by a hyphen (-).
- The first and last VSNs in the VSN range have the same length.
- VSNs and VSN ranges in a list must be separated by commas
- there must be no blanks
- Any number of hyphens ("-") or commas (",") are permitted at the end of the list.

A possible entry might be: A00001–A00030,B00003,B00005,B00010–B00015,---

ROBAR_INFO_MSG configuration parameter

If **ROBAR_INFO_MSG=YES** the **ROBNxxx** messages are output to the BS2000 console. The messages are suppressed if this configuration parameter is **NO** or not defined.

ROBNxxx messages are always output as a reaction to **Nxxx** error messages that originate in the archive system. It is not however practical to output **ROBNxxx** messages in BS2000 systems as generally measures to eliminate the relevant error are initiated at the same time as the archive system error messages and more serious errors are displayed directly on the screen using the relevant ROBAR messages.

ROBOT_OFF_MSG configuration parameter

As soon as the robot switches to **OFF** mode, an appropriate message is sent to the BS2000 systems. This message is always a **PAUSE** message unless the configuration parameter **ROBOT_OFF_MSG** exists and has the value **TYPE**.

Default value: **PAUSE**

INIT_RESTART_OPTION configuration parameter

INIT_RESTART_OPTION defines whether the automatic restart is enabled (**YES**) or not (**NO**) for the instance when a ROBAR-SV instance is started for the first time. See section [“Automatic restart of ROBAR-SV instances” on page 46](#).

Default value: **NO**

```

# Global definitions
#
# gen_global_info
# archive_type=scsi-1
# 'scsi-1' should be always set for the SCSI interface
# original_version=<version_1..4>
#     Version of the ROBAR-SV installation.
#     The identity of this parameter and the version of the actually
#     installed ROBAR-SV is expected.
# location=<robot_location_name_1..8>
#     location must match the location name defined in MAREN and NDM
#     (see also /ADD-DEVICE-DEPOT)
# archive_serial_number=<instance_number_(1|2|3|4)>
# multi_processing_level=<multi_processing_level_(1|..|10)>
# robot_address1=<interface>(<library_device_address_1..32>)
#     <interface> : SCSI
#     <libray_device_address_1..32>
#         Either full pathname of the device special file (e.g. /dev/sg3)
#         or full pathname of the persistent device node file
#         (example: /dev/rob/1ADIC_203100195_LL5)
# notification_host=*ALL|<name_1..6>
#     defines the target for the commands TYPE, PAUSE or COMMAND
#     transmitted by ROBAR.
#     Its value is the host alias name defined in gen_hosts.
# trace_limit=<maximum trace file size in bytes>
#     If this parameter is not specified, then 1000000 is assumed.
# volume_error_limit=<maximum error number per volume>
#     If this parameter is not specified, then 3 is assumed.
# device_error_limit=<maximum error number per device>
#     If this parameter is not specified, then 3 is assumed.
# repetition_count=<counter_value>
#     <counter_value> is a positive integer number.
#     The repetition_count defines the maximum number of connection
#     attempts to the archive system during its startup.
#     If this parameter is omitted then the value 1 is assumed.
# Notice : However to ensure a successfully communication start also
#     in the start up phase of the robot we suggest a value of
#     at least 20.
# hicap_var=<value_(ON|OFF)>
#     This parameter controls the transmission of MAREN-related messages
#     for export or import requests.
#     ON  : only the MAREN-hosts defined in gen_maren_processors will be
#           informed.
#     OFF : if there are MAREN-hosts defined in gen_maren_processors they
#           will be informed. Otherwise all hosts defined in gen_hosts
#           are informed.
#     Default value is OFF.
# end_global_info

```

```
gen_global_info
archive_type=scsi-1
original_version=V7.5
location=ROBOTER1
archive_serial_number=1
multi_processing_level=10
robot_address1=SCSI(/dev/rob/1ADIC_203100195_LL5)
notification_host=HOST01
trace_limit=10000000
volume_error_limit=3
device_error_limit=3
repetition_count=20
hicap_var=OFF
end_global_info
```

Notes on the section Global definitions (SCSI interface)

archive_type configuration parameter

Defines the type of archive system.

Default value: `scsi_1` (may not be changed).

location configuration parameter

A storage location name is required for the MTC devices administered by ROBAR.

A separate storage location name must be defined for each ROBAR-SV instance in accordance with the MTC devices administered and the archive system.

archive_serial_number configuration parameter

This configuration parameter is only described for reasons of compatibility.

Specification of a value <1 .. 4> is required to create default names for local CMX names.

A different value should be defined for each ROBAR-SV instance if the default names are used for local CMX names.

robot_address1 configuration parameter

See [page 196](#).

repetition_count configuration parameter

When ROBAR-SV is started, a connection to the archive system is established. The response from the archive system is expected within 20 seconds. If there is no response from the archive system, the connection is closed down and all processes of the ROBAR-SV instance are terminated.

The number of connection establishment attempts can be defined using the `repetition_count` configuration parameter. Default value: `repetition_count=1`.

```
# Host definitions
#
# gen_hosts
# <host_alias_name_1..6> partner=<TNS_partner_name_8..8>
#                               [local=<TNS_local_name_1..8>]
#   <host_alias_name_1..6>
#       identifies the system of the ROBAR client installation.
#   <TNS_partner_name_8..8>
#       identifies the system of the ROBAR client installation
#       in the configuration file for CMX.
#   <TNS_local_name_1..8>
#       identifies the ROBAR client application. If it is
#       omitted a name will be created concatenating
#       "robar" and "(archive_serial_number - 1) + 40".
# [...]
# end_hosts

gen_hosts
HOST01 partner=PARNAME1 local=LOCNA1
HOST02 partner=PARNAME2 local=LOCNA2
HOST03 partner=PARNAME3 local=LOCNA3
end_hosts
```

```

# Device definitions
#
# gen_devices
# for native MTC device processing
# <device_mnemonic> type=<device_type> [RRF_dir=<RRFname_1..10>]
# devaddr=<DevAddr_(256|..|4095)> [devname=<DevName>]
# logic_library_lun=<LUN_number_(1|2|...|255)>
#
# <device_mnemonic>
# the mnemonic device name in BS2000.
# It consists of 2 or 4 letter and/or digits.
# <device_type>
# a device type defined in BS2000, i.e. LT0-U2.
# <RRFname_1..10>
# identifies the directory containing the Robar Rule File
# to be used for this device.
# <DevName>
# is a character string of length 2 (0..9, A..Z).
# It allows to convert a 4 byte device mnemonic into a 2 byte
# archive system device identification.
# Due to compatibility reasons ROBAR-SV uses 2 Byte mnemonics
# internally. Therefore this parameter is important for the
# archive systems.
# <DevAddr_(256|..|4095)>
# This value establishes the relationship between the device
# mnemonic and the element address of the MTC drive in the
# scalar i archive system.
# DevAddr conforms with the Data Transfer Element Address
# of the MTC drive in the assigned logical library.
# <LUN_number_(1|2|...|255)>
# LUN number of the logical library which the drive
# is assigned to.
# [...]
# end_devices

gen_devices
A0 type=TAPE-U2 RRF_dir=TYPE-1 devaddr=256 logic_library_LUN=1
A001 type=TAPE-U2 RRF_dir=TYPE-1 devname=M1 devaddr=257 logic_library_LUN=1
end_devices

```

Notes on the section Device definitions (SCSI interface)

RRF_dir configuration parameter

See [chapter “ROBAR rule files” on page 247](#).

Names / addresses of the MTC devices

The name and consequently also the address of the MTC devices differ in BS2000 and the archive system. The mnemonic device name in BS2000 cannot be used directly. In this section you must specify the assignments for the device address.

In this section an entry with the assignment of the mnemonic device name to the `devaddr` and `logic_library_LUN` configuration parameters must exist for each device. The relationship to the mnemonic name of the tape device is preset by the BS2000 generation.



In the **Scalar i500** archive system `<LUN_number>=1`. You can ascertain the device addresses `<DevAddr>` using the Internet access from the Reports menu item, All Slots submenu, Element Address column.

In the **Scalar i2000** and **i6000** archive system you can ascertain the device addresses `<DevAddr>` and the LUN `<LUN_number>` using the LMC.

You will find `<LUN_number>` (when you specify the physical library) in the Setup --> Blades --> Access --> FC Host --> LUN Mapping menu.

You will find `<DevAddr>` in the View menu (when you specify the partition), then in the Monitor menu and there under the Drives menu. The WWPN and other information for the configured devices are displayed in the Drive Status window. The devices are displayed in ascending order in accordance with their position in the archive system's housing. The position is shown in the Location column. According to the SCSI Reference Guide, the start address for the drives (Data Transfer Elements) has the value 256 (hexadecimal: 0100). Consequently the first device displayed in the table will be assigned the value 256 in the `devaddr` configuration parameter. The other devices will each receive an element address which is incremented by 1.

MTC devices can be assigned a 4-character device name (4-byte MN). However, at the interface to the archive systems ROBAR-SV still only uses a 2-character field for the device name (`<DevName>`).

If 4-byte MNs are used in a BS2000 system, ROBAR-SV must convert the 4-byte MN into the 2-byte device name of the archive system. The `devname = <DevName>` operand is provided for this purpose in the device definitions. The device names must be unique within an archive system.

Example

```
# Device definitions
gen_devices
A000 type=LT0-U2 devname=G1 devaddr=256 logic_library_LUN=1
A001 type=LT0-U2 devname=G2 devaddr=257 logic_library_LUN=1
A002 type=LT0-U2 devname=G3 devaddr=258 logic_library_LUN=1
F000 type=LT0-U2 devname=G4 devaddr=259 logic_library_LUN=1
. . .
FFFF type=LT0-U2 devname=ZZ devaddr=... logic_library_LUN=1
end_devices
```



It is advisable to use either 2-byte MNs or 4-byte MNs for the tape devices of an archive system.

A mixture of 2-byte MNs and 4-byte MNs can also occur in the device definition. In this case you must ensure that a 2-byte MN is not used as `<DevName>` in one of the `devname = <DevName>` operands.

ROBAR-SV also uses a 2-byte MN automatically as a 2-byte device name (in this case the `devname` operand can be omitted).

Example

```
# Device definitions
gen_devices
T0 type=LT0-U2 devaddr=256 logic_library_LUN=1
T1 type=LT0-U2 devaddr=257 logic_library_LUN=1
A000 type=LT0-U2 devname=M3 devaddr=258 logic_library_LUN=1
A001 type=LT0-U2 devname=M4 devaddr=259 logic_library_LUN=1
A002 type=LT0-U2 devname=M5 devaddr=260 logic_library_LUN=1
F000 type=LT0-U2 devname=M6 devaddr=261 logic_library_LUN=1
. . .
F123 type=LT0-U2 devname=T1    !!! INHIBITED !!!
. . .
FFFF type=LT0-U2 devname=ZZ devaddr=... logic_library_LUN=1
end_devices
```



```
# MAREN host definitions
#
# gen_maren_processors
# <host alias list (1 to 10 items)>|*NO_HOST|*ALLHOST
# Notice : physically exists only one central MAREN host which controls the
#           MAREN-catalog. Therefore the definition of more than one processor
#           could cause redundant updates of the MAREN-catalog.
# The central MAREN host has to be attached.
# end_maren_processors

gen_maren_processors
HOST01
end_maren_processors

# Host-VSN definitions
#
# gen_hosts_vsn
# <TNS_partner_name_8..8> <vsn_list>;
# A list of up to 1024 characters is allowed for each partner system.
#   <TNS_partner_name_8..8> is the partner as defined in gen_hosts.
#   <vsn_list> is
#       <vsn_name_1..6>;|<vsn_name_1..6>--<vsn_name_1..6>;[<vsn_list>;]
#   <vsn_name_1..6> volume identifier.
# [...]
# end_hosts_vsn

gen_hosts_vsn
PARNAME1 volna1-volna2;
PARNAME2 volna3-volna4;volna5-volna6;volnak-volnan;
PARNAME3 volna7-volna8;voln9-voln10;volna1;volnam;
end_hosts_vsn
```

Notes on the section Host VSN definitions (SCSI interface)

You can define VSN number ranges in two ways in ROBAR-SV:

- Definition of global VSN number ranges via the configuration parameter `ROBAR_ARCHIV` (see [page 218](#)). This means, however, that the VSNs entered there can be used by all BS2000 systems which communicate with ROBAR-SV.
- Definition of server-related VSN number ranges in the ROBAR-SV configuration file. This enables you to assign VSN-dependent actions to selected servers (multiclient capability).

In the `Host VSN definition` section you can define lists in the form

```
<Hostname> <vsnbeg>--<vsnend>;      (specification of range)
```

and / or

```
<Hostname> <vsn>; ...; <vsn>;      (specification of single VSN)
```

`<vsnbeg>` and `<vsnend>` specify the first and last elements in a range of MTC VSNs.

When a range is specified, the letters in `<vsnbeg>` and `<vsnend>` must match; the range is defined by the number part. The number in `<vsnbeg>` must be less than that in `<vsnend>`. Example: D00100–D00800.

For compatibility reasons, all VSNs defined in the `gen_hosts_vsn` section must also be contained in the set of values of the `ROBAR_ARCHIV` configuration parameter. Otherwise the definitions in the `gen_hosts_vsn` section will be meaningless. The lines in the `gen_hosts_vsn` lines must be terminated by a semicolon.

Example

```
gen_env_vars
ROBAR_ARCHIV=A00100–A01200,B11111,C10000–C11000,D00100–D00800,D02222,
D03333,E00500–E01000
end_env_vars

gen_hosts
S200 partner=PAD1EDXX local=PAD1ED
SANDRA partner=PAD3EDXX local=PAD3ED
end_hosts

gen_hosts_vsn
PAD1EDXX A00100–A01200;B11111;C10000–C11000;
PAD3EDXX D00100–D00800;D02222;D03333;E00500–E01000;
end_hosts_vsn
```

6.5.3.5 Sample of the interface-specific configuration file (ABBA interface)

The sample configuration file `/etc/robar/abba.conf.d/templates/template.txt` below is supplied for the ABBA interface.

The file contains notes in English and German. Only the English comments are shown in this manual.

The notes on the various sections of the file are contained at the end of the section concerned; they are arranged according to the order of their occurrence.

```
# This file is an example of an editable configuration file for
# ROBAR-SV 7.5A for ABBA interface.
# It serves as a template to create real configurations for the virtual
# tape library system ETERNUS CS HE (formerly: CentricStor).
#
# As for the handling of configuration files, please refer to the section
# "Configuring ROBAR-SV" in the ROBAR manual,
#
# The following shortcuts are used in this context:
# <text_m..n> : string of characters; m, n are integers and m..n defines
#               the minimal and maximal fieldwidth.
# <instance_number_(l|m|..|n)> : the available values are enumerated from l up
#                               to n. l, m, n can be integers, strings, $, #, @.
# Notice : it is an error to define parameters not supported with values!
#         Each parameter must always have a value.
#         All string identifiers are case sensitive.

# Internal environment variables
#
# The next line is a specially formatted comment to display optionally
# additional user info in ROBAR-SV Manager.
# It has to begin with #%INFO%= without blank characters before it.
# Max. up to 80 characters after "=" can be displayed.
# Example:
#%INFO%= Eternus CS HE
#
# gen_env_vars
# CLOSE_DISPLAY=YES|NO
#         If CLOSE_DISPLAY=YES, open DISPLAY and MANUAL menus are closed when
#         ROBAR-SV is started.
# LTRACE=YES|NO
# ROBAR_TRACE=YES|NO
```

```
# SERVER_TRACE=YES|NO
#     The LTRACE, ROBAR_TRACE and SERVER_TRACE variables are used
#     internally and are therefore not described here.
# MANCHECK=YES|NO
#     Input parameter check in commands of the menu MANUAL
# MAX_CLEAN=<mounts_number>
#     Maximum number of mounts of a cleaning cartridge.
# MIN_SCRATCH=<number_of_MTC>
#     Minimum number of MTCs in standard freepool.
# ROB_STAT_NOTIF=TYPE|PAUSE
#     If this variable is defined, a TYPE or a PAUSE message
#     is output depending on the setting.
# ROBAR_ARCHIV=<vs_n_list>
#     Archive numbers (VSNs) which may be processed by this
#     ROBAR-SV instance.
# ROBAR_INFO_MSG=YES|NO
#     Specifies whether ROBNxxx messages are to be output
#     to the BS2000 console
# ROBOT_OFF_MSG=TYPE|PAUSE
#     If the robot switches to OFF mode, the message sent to
#     the BS2000 system is a TYPE or a PAUSE message.
# INIT_RESTART_OPTION=YES|NO
#     Sets the initial value of automatic instance restart during
#     the first start of DEFINED instance.
#     This can be dynamically changed afterwards with
#     SET_RESTART_OPTION_ABBA command or by the web application.
# end_env_vars
```

```
gen_env_vars
CLOSE_DISPLAY=NO
LTRACE=NO
ROBAR_TRACE=NO
SERVER_TRACE=NO
MANCHECK=NO
MAX_CLEAN=100
MIN_SCRATCH=50
#ROB_STAT_NOTIF=
#ROBAR_ARCHIV=volna1-volna8,volna1,volnam
ROBAR_INFO_MSG=NO
ROBOT_OFF_MSG=PAUSE
INIT_RESTART_OPTION=NO
end_env_vars
```

Notes on the section Internal environment variables (ABBA interface)

See also the notes on [page 217](#).

MAX_CLEAN configuration parameter

MAX_CLEAN contains the maximum number of mounts of a cleaning cartridge. When this number is reached, the cleaning cartridge is removed from the archive and placed in the output unit. Default value: 100

MIN_SCRATCH configuration parameter

MIN_SCRATCH specifies the minimum number of MTCs in the ROBAR standard freepool (scratch cartridges). Whenever a non-specific volume request is to be satisfied from the ROBAR standard freepool, a check is made as to whether the number has fallen below this limit. If so, an appropriate message is displayed on the console of the BS2000 system. Default value: 50

INIT_RESTART_OPTION configuration parameter

INIT_RESTART_OPTION defines whether the automatic restart is enabled (YES) or not (NO) for the instance when a ROBAR-SV instance is started for the first time. See section [“Automatic restart of ROBAR-SV instances” on page 46](#).

Default value: NO

```

# Global definitions
#
# gen_global_info
# archive_type=CentricStor
#     CentricStor - ETERNUS CS HE (CentricStor) virtual archive system
# original_version=<version_1..4>
#     Version of the ROBAR-SV installation.
#     The identity of this parameter and the version of the actually
#     installed ROBAR-SV is expected.
# location=<robot_location_name_1..8>
#     location must match the location name defined in MAREN and NDM
#     (see also /ADD-DEVICE-DEPOT)
# archive_serial_number=<instance_number_(1|2|3|4)>
# robots_count=<number_of_robot_arms_(1|2)>
#     Must be 1 for ETERNUS CS.
# robot_devid=IMPLICIT|EXPLICIT
#     IMPLICIT means that the AML device identification is computed on
#     basis of the drive position in the ROBAR-SV configuration file.
#     EXPLICIT means the device mnemonic of the ROBAR-SV configuration
#     file is used as AML device identifier.
# multi_processing_level=<multi_processing_level_(1|..|10)>
# robot_address1=<connection_type>(<AML_address>)
#     <connection_type> : TCP/IP.
#     <AML_address> its format depends on the connection type.
#     for TCP/IP: <AML_address_1..253>,<port_number_1..5>.
#     <AML_address> can be specified as numeric IP address or
#     by FQDN.
# robar_host_id1=<name_2..2> : the identifier must be assigned in the
#     configuration of the archive system to a host
#     resp. host alias name.
# robot_output_area=*DEFAULT|<name_3..3>
# robot_input_area=*DEFAULT|<name_3..3>
# notification_host=*ALL|<name_1..6>
#     defines the target for the commands TYPE, PAUSE or COMMAND
#     transmitted by ROBAR.
#     Its value is the host alias name defined in gen_hosts.
# trace_limit=<maximum trace file size in bytes>
#     If this parameter is not specified, then 1000000 is assumed.
# volume_error_limit=<maximum error number per volume>
#     If this parameter is not specified, then 3 is assumed.
# device_error_limit=<maximum error number per device>
#     If this parameter is not specified, then 3 is assumed.
# repetition_count=<counter_value>
#     <counter_value> is a positive integer number.
#     The repetition_count defines the maximum number of connection
#     attempts to the archive system during its startup.
#     If this parameter is omitted then the value 1 is assumed.
# Notice : However to ensure a successfully communication start also

```

```
#           in the start up phase of the robot we suggest a value of
#           at least 20.
# hicap_var=<value_(ON|OFF)>
#           This parameter controls the transmission of MAREN-related messages
#           for export or import requests.
#           ON : only the MAREN-hosts defined in gen_maren_processors will be
#                 informed.
#           OFF : if there are MAREN-hosts defined in gen_maren_processors they
#                 will be informed. Otherwise all hosts defined in gen_hosts
#                 are informed.
#           Default value is OFF.
# end_global_info
```

```
gen_global_info
archive_type=CentricStor
original_version=V7.5
location=ROBOTER1
archive_serial_number=1
robots_count=1
robot_devid=EXPLICIT
clean_count=10
multi_processing_level=10
robot_address1=TCP/IP(193.192.191.190,7055)
robar_host_id1=H1
robot_output_area=*DEFAULT
robot_input_area=*DEFAULT
notification_host=HOST01
trace_limit=10000000
volume_error_limit=3
device_error_limit=3
repetition_count=1
hicap_var=OFF
end_global_info
```

Notes on the section Global definitions (ABBA interface)

See also the notes on [page 220](#).

archive_type configuration parameter
Defines the type of archive system.
Default value: `CentricStor` (must not be changed).

robots_count configuration parameter
Number of robots (ETERNUS CS is supported only as a single-robot system).
Default value: 1 (must not be changed).

robot_devid configuration parameter (mnemonic device names)
To simplify device configuration, archive systems support device names in mnemonic format (00..ZZ). The configuration parameter `robot_devid` can be used to stipulate that the device mnemonics will be used in the ROBAR configuration to address the devices operated by the robot in the commands intended for the robot.

The mode of address to be used is selected in the configuration parameter `robot_devid`. If the value `EXPLICIT` is defined for `robot_devid`, the mnemonic format is used. If the value `IMPLICIT` is defined for `robot_devid` (not recommended), the “numbered topologic form” is used.

Further explanations are provided in [“Notes on the section Device definitions \(ABBA interface\)” on page 235](#).

Configuration parameter `robot_address1`
The AML address for the configuration parameter `robot_address1` must be included in the file `/etc/hosts`.

`robot_input_area`, `robot_output_area` configuration parameters
Name of the logical input resp. output area to be used by ROBAR-SV
(*DEFAULT: setting in the archive system).

`repetition_count` configuration parameter
When ROBAR-SV is started, a connection to the archive system is established. The response from the archive system is expected within 20 seconds. If there is no response from the archive system, the connection is closed down and all processes of the ROBAR-SV instance are terminated.

The number of connection establishment attempts can be defined using the `repetition_count` configuration parameter.
Default value: `repetition_count=1`.

```
# Host definitions
#
# gen_hosts
# <host_alias_name_1..6> partner=<TNS_partner_name_8..8>
#                               [local=<TNS_local_name_1..8>]
#   <host_alias_name_1..6>
#       identifies the system of the ROBAR client installation.
#   <TNS_partner_name_8..8>
#       identifies the system of the ROBAR client installation
#       in the configuration file for CMX.
#   <TNS_local_name_1..8>
#       identifies the ROBAR client application. If it is
#       omitted a name will be created concatenating
#       "robar" and "(archive_serial_number - 1) + 40".
# [...]
# end_hosts

gen_hosts
HOST01 partner=PARNAME1 local=LOCNA1
HOST02 partner=PARNAME2 local=LOCNA2
HOST03 partner=PARNAME3 local=LOCNA3
end_hosts
```

```
# Device definitions
#
# gen_devices
#
# for CentricStor operation
#   <device_mnemonic> robot=<managing_robot> [type=<device_type>]
#                                     [devname=<DevName>]
#
#   <device_mnemonic>
#       the mnemonic device name in BS2000.
#       It consists of 2 or 4 letter and/or digits.
#   <managing_robot_(0|1|2)>
#       the robot arm number (0 for manual drives).
#   <device type>
#       a device type defined in BS2000, i.e. TAPE-C4.
#   <DevName>
#       is a character string of length 2 (0..9, A..Z).
#       It allows to convert a 4 byte host device mnemonic in a 2 byte
#       archive system device identification.
#       DevName must be identical with the related device name in the
#       archive system configuration.
# [...]
# end_devices

gen_devices
# CentricStor devices
T0 type=TAPE-C4 robot=1
T1 type=TAPE-C4 robot=1
end_devices
```

Notes on the section Device definitions (ABBA interface)

Names / addresses of the MTC devices

MTC devices can be assigned a 4-character device name (4-byte MN). However, at the interface to the archive systems ROBAR-SV still only uses a 2-character field for the device name (<DevName>).

robot_devid=EXPLICIT and 4-byte MNs in BS2000



The use of 4-byte MNs and device names means that the device names used in the server and archive system are disjunctive. When multiple large ETERNUS CS systems are used, for example, it may also be necessary to assign identical device names. This increases the diagnostic effort when a fault occurs. You are therefore recommended to convert operation to 4-byte MNs only if the set of values for the 2-byte MNs is no longer adequate for the entire device configuration.

If 4-byte MNs are used in a BS2000 system, ROBAR-SV must convert the 4-byte MN into the 2-byte device name of the archive system. The `devname = <DevName>` operand is provided for this purpose in the device definitions. The two-byte device identifier (set of values: 0..9, A..Z) which must be specified there corresponds to the device name definition in the device configuration of the archive system (e.g. `DevName` in the ETERNUS CS configuration tool GXCC). The device names must be unique within an archive system.

Example

```
# Device definitions
gen_devices
A000 type=TAPE-C4 devname=G1
A001 type=TAPE-C4 devname=G2
A002 type=TAPE-C4 devname=G3
F000 type=TAPE-C4 devname=G4
. . .
FFFF type=TAPE-C4 devname=ZZ
end_devices
```



It is advisable to use either 2-byte MNs or 4-byte MNs for the (virtual) tape devices of an archive system.

A mixture of 2-byte MNs and 4-byte MNs can also occur in the device definition. In this case you must ensure that a 2-byte MN is not used as <DevName> in one of the `devname = <DevName>` operands. ROBAR-SV also uses a 2-byte MN automatically as a 2-byte device name.

Example

```
# Device definitions
gen_devices
T0 type=TAPE-C4
T1 type=TAPE-C4
A000 type=TAPE-C4 devname=M3
A001 type=TAPE-C4 devname=M4
A002 type=TAPE-C4 devname=M5
F000 type=TAPE-C4 devname=M6
. . .
F123 type=TAPE-C4 devname=T1    !!! INHIBITED !!!
. . .
FFFF type=TAPE-C4 devname=ZZ
end_devices
```

robot_devid=IMPLICIT and 4-byte MNs in BS2000

You are recommended not to use **IMPLICIT** addressing mode any longer. However, ROBAR-SV still supports this mode and accepts the specification of 2-byte and 4-byte MNs in the device definitions section for up to 99 devices. The `devname` operand may not be specified in **IMPLICIT** addressing mode.

```

# MAREN host definitions
#
# gen_maren_processors
# <host alias list (1 to 10 items)>|*NO_HOST|*ALLHOST
# Notice : physically exists only one central MAREN host which controls the
#           MAREN-catalog. Therefore the definition of more than one processor
#           could cause redundant updates of the MAREN-catalog.
# The central MAREN host has to be attached.
# end_maren_processors

gen_maren_processors
HOST01
end_maren_processors

# Host-VSN definitions
#
# gen_hosts_vsn
# <TNS_partner_name_8..8> <vsn_list>;
# A list of up to 1024 characters is allowed for each partner system.
#   <TNS_partner_name_8..8> is the partner as defined in gen_hosts.
#   <vsn_list> is
#       <vsn_name_1..6>;|<vsn_name_1..6>--<vsn_name_1..6>;[<vsn_list>;]
#   <vsn_name_1..6> volume identifier.
# [...]
# end_hosts_vsn

gen_hosts_vsn
PARNAME1 volna1-volna2;
PARNAME2 volna3-volna4;volna5-volna6;volnak-volnan;
PARNAME3 volna7-volna8;voln9-voln10;volna1;volnam;
end_hosts_vsn

```

Notes on the section Host VSN definitions (ABBA interface)

See the notes on [page 226](#).

6.5.4 Generation of names for CMX

ROBAR-SV communicates with ROBAR-CL via CMX (see “CMX Communication Manager” [12, 13]). You will find further details on the installation and configuration of CMX in the manual “CMX Communication Manager” [12] and in the hardware description of the ROBAR server.

Systems support must therefore set up the following:

- the data for the connection to the remote partner
- Local application name which is addressed by the remote partner (in ROBAR V7.5 and higher the local name can also be generated automatically by ROBAR, see [section “Add a new partner” on page 145](#))

So that ROBAR can set up connections, requisite names must be entered in the Transport Name Service (TNS). A name for the local system and a name for the remote system must be entered for each connection. For the remote system, only the fifth name part is used.

The ROBAR-SV Manager offers user-friendly functions to configure and manage partner systems and local names, see [section “Managing the partner configuration \(CMX\) of the ROBAR server” on page 144](#).

Local and global name

A local and global name must be defined in the Transport Service directory (TS directory) for each remote system.

The global name is used as a keyword and allows remote applications to be accessed via a TCP/IP connection. It must be unique within the ROBAR server. The global name describes the TCP/IP connection and creates a link to the address and name or port of the remote application (depending on the connection type).

The local name is the name of the local application whose task it is to communicate with the remote application. Like the global name, the local name must also be unique within the ROBAR server.

Both a global (TNS partner name in the `gen_hosts` section) and a local name (`local` in the `gen_hosts` section) must be defined in the interface-specific ROBAR-SV configuration file for each remote system with which a communication link is to be established. The global names for the remote systems are freely selectable but must be specified in uppercase letters and comprise exactly 8 characters (e.g. `ROB1WAN1`).

Example

Determine the communication with the BS2000 systems (only the part affected by the communication is described):

```
# Global definitions
gen_global_info
...
archive_serial_number=1
...
end_global_info

# Host definitions
gen_hosts
* definition of GLOBAL names (partner=) and LOCAL names (local=)
* via RFC1006 (ISO protocol on TCP/IP network)
EVARFC partner=RORFCEVA local=robrfc1
end_hosts
...
```

The global names defined in the TS directory describe the TCP/IP connection. Name and IP address of the ROBAR server must be known in the (remote) BS2000 system (BCAM component).

```
RORFCEVA\
      TA      RFC1006   193.210.194.170 PORT 102 T'ROBAR1DC'
robrfc1\
      TSEL    RFC1006   T'ROBRFC1'
```

You can output a TNS directory to a file using the following command: `tnsxcom -D <file>`. You can edit the `<file>` file (e.g. using `vi`), for instance to make a new BS2000 system known.

Enter the following command to update the TNS directory (root authorization required): `tnsxcom -u <file>`.

6.5.5 Multiprocessing

Requests addressed to a ROBAR-SV instance are processed asynchronously and simultaneously (multi-processing).

The multi-processing concept employed by ROBAR-SV allows the archive system to be used to the full. While a normal MTC processing request is waiting to be executed, for instance, requests from other processes, such as a request to the archive system, can be executed. A single ROBAR-SV installation can process up to 10 requests per archive system and robot arm at the same time.

You define the number of processes that can be performed simultaneously in the interface-specific ROBAR-SV configuration file. At least one process must, but no more than 10 processes can be defined. The default value is 10 processes (see note on [page 242](#)).

Parallel processing improves system performance when the request currently being processed by ROBAR-SV cannot be continued until a certain event has taken place (e.g. waiting for `NKVT097 UNLOAD INITIATED`).

Cleaning up a volume after use

Depending on the tape position, an indefinite period of time may pass between `UNLOAD INITIATED` and `Volume ready (for cleanup)`. Therefore ROBAR-SV assigned `KEEP` requests for cleaning up a used volume at relatively short intervals. With the availability of the `DISMOUNT MANAGERS` (see Reference Guides of the archive systems), this procedure has been changed. The `DISMOUNT MANAGER` receives the `KEEP` request and controls the `KEEP` cycle according to the preset values.



The following paragraph only applies to archive systems **without** `DISMOUNT MANAGER`:

`KEEP` requests can be delayed with delay times that can be defined in the ROBAR rule file. In this way you can avoid the robot being blocked by permanent `KEEP` requests. This means that longer delay times can be defined without robot processing being interrupted. Longer delay times can be set with the following options:

- `MRV0i` for exporting after a normal `UNLOAD` message
 - `MRVFi` and `MRVGi` for dismounting after an emergency unload (if an error occurs)
 - `MRVAi` for cleaning the MTC device
- `i = 2` for device 3590E
`i = 3` for device LTO-Ux

Notes on setting wait times

The adjustment of the wait times in the direction of the maximum MTC rewind times does guarantee the highest level of robot availability (no interruption through unsuccessful UNMOUNT attempts), however the availability of the MTC devices and the cartridges is frequently not satisfactory. Such settings are only practical if there is a large number of MTC devices available and the same cartridge is rarely affected by successive requests. The optimum values for the settings can be determined by observing the behavior of the robot.

The following table contains information on the settings that can be used to eliminate the problems described.

Problem	Option	Action
Cartridge rewind time is too long	MRV01	Increase the value
MTC device not available as the robot is removing the MTC from the MTC device long after unloading	MRV01	Reduce the value
Robot is waiting for the cleaning cartridge to be unloaded	MRVAi ¹	Increase the value
MTC device not available as the robot is removing the cleaning cartridge from the MTC device long after unloading	MRVAi ¹	Reduce the value
Archive system timeout (message N206) after message NKVT097 occurred	MRV01	Increase the value
Archive system timeout (message N206) after KEEP for cleaning cartridges	MRVAi ¹	Increase the value
After a device error (message EXC0858), the robot remains in front of the affected MTC device	MRVFi ¹ MRVGi ¹	Increase the value ² Reduce the value ²
After a device error (message EXC0858), the robot does not remove the cartridge from the affected MTC device immediately	MRVFi ¹ MRVGi ¹	Reduce the value ² Increase the value ²

¹ i = 2 for device type 3590E; i = 3 for device typeLTO-Ux; i = 4 for ETERNUS CS

² each by the same value

The most frequent reason for time loss in the archive system is the requesting of a robot KEEP operation for an MTC device even though the tape will be removed in a few seconds time. This situation arises in the following cases:

- A BS2000 task releases a cartridge, NDM then informs the system via console message NKVT097 that the cartridge is being unloaded and instructs the MTC device to rewind and unload the cartridge. ROBAR reacts to message NKVT097 by requesting a robot KEEP operation for this MTC device. The archive system is blocked until the cartridge is unloaded or an archive system timeout occurs.

- With certain MTC device or cartridge errors (e.g. loss of tape tension) the emergency unload process is initiated for the affected device (by ROBAR using the robot command `ULU` or using the operator command `/UNLOAD`). The cartridge is then rewound slowly and then unloaded. If a `KEEP` operation is requested during this phase, the robot is blocked for the duration of the rewind time (which can last several minutes).
- ROBAR initiates the mounting of a cleaning cartridge according to the parameters set, but also when eliminating certain MTC device errors. If a `KEEP` operation is requested for this cleaning cartridge immediately after `MOUNT CLEAN`, it blocks the robot until the cleaning process is complete.



The default of ten processes defined in the `multiprocessing_level` configuration parameter (maximum value) need only be replaced with a lower value if the memory of the ROBAR server becomes saturated.

6.5.6 Configuration variants

ROBAR-SV permits configuration variants for real archive systems:

6.5.6.1 Installing ROBAR-SV in a uniform configuration

A uniform device type (LTO-Ux) is used in the archive system.

In a uniform configuration

- only one ROBAR-SV instance needs to be installed
- only one ROBAR rule file type must be defined for the ROBAR device configuration.

6.5.6.2 ROBAR-SV in the case of multiple configuration

Multiple ROBAR-SV instances control separate areas in one archive system.

The following points must be noted in multiple configurations:

- One ROBAR instance can administer exactly one logical archive system.
- If two ROBAR-SV instances are to administer two different areas (storage locations) in a single archive system, the archive system must have been set up accordingly, e.g. by means of partitioning (SCSI interface) or configuration (ABBA interface).

6.5.6.3 Installing storage locations

Additional manually operated devices

However, if MTC devices of the same type exist outside the archive system, a storage location must be defined for the devices and cartridges managed by ROBAR. In this case, the use of MAREN (for cartridge storage locations) and NDM DEVICE-DEPOT (to guarantee that the storage locations of the devices match the storage locations of the cartridges) is mandatory.

Several archive systems

If ROBAR is to manage several archive systems or partitions, a separate ROBAR-SV instance with its interface-specific ROBAR-SV configuration file and with its own storage location is required for each archive system or partition.

6.6 Upgrading from previous ROBAR versions

The current ROBAR version can execute from a particular version of BS2000. Ensure that the ROBAR versions in both BS2000 and on the ROBAR server are identical or are at least compatible.

MAREN can be used with ROBAR from a particular version of MAREN.

All version dependencies are described in the ROBAR Release Notice. The hardware and software dependencies of ROBAR are also described there.

Notes for ROBAR-CL

- If you made modifications to any already existing ROBAR-CL files, the relevant files should be saved before installing ROBAR-CL.
- Any installation of ROBAR-CL will overwrite all existing ROBAR-CL files.

Notes for ROBAR-SV V6.0 and earlier

ROBAR-SV V7.5 uses a different structure of files and directories from ROBAR-SV V6.0 and earlier.

- You do not need to save any files of ROBAR-SV.
- The files of ROBAR-SV are used to migrate to ROBAR-SV V7.5. ROBAR-SV should therefore not be uninstalled.

The configuration files of ROBAR-SV V7.5 are not compatible with ROBAR-SV V6.0 and earlier.

- Configuration files of ROBAR-SV can be converted to interface-specific configuration files of ROBAR-SV V7.5 using the ROBAR-SV Manager, see [section “Migrating an existing configuration file” on page 213](#).
- Configuration files of ROBAR-SV can also be converted manually to interface-specific configuration files of ROBAR-SV V7.5. For this purpose they must be stored in the relevant directories, see [section “Directories and files of ROBAR-SV” on page 202](#).

In this case you are recommended to integrate the differing configuration data of ROBAR-SV in the sample configuration files of ROBAR-SV V7.5.

- In ROBAR-SV V6.5 and higher configuration files no longer need to be converted manually to binary format. This is done automatically by ROBAR-SV when the ROBAR-SV instance is started.

Note on the ROBAR rule files (RRFs)

When a ROBAR-SV instance is started, RRFs, together with the other files of the ROBAR-SV instance, are placed in the `/var/lib/<interface>/<instance>/message_storage` directory. There they can be overwritten with modified RRFs from the previous version.

7 ROBAR rule files

To enable you to deal with all the different eventualities that may occur in the tape processing handled by a data center, you are allowed to define your own console messages and message processing by ROBAR. This is done using device-specific execution control files, the so-called ROBAR rule files (RRF), which are used to define the actions that the archive system should perform in specific situations.

In addition to the BS2000 files `SYSPAR.ROBAR-CL.<ver>.MESSAGES` and `SYSPAR.ROBAR-CL.<ver>.PROZPARAM`, ROBAR uses the following RRFs on the ROBAR server (gray background in table):

File name	Meaning	See
<code>SYSPAR.ROBAR-CL.<ver>.MESSAGES</code>	This file contains the message numbers of the console message that ROBAR-CL passes to ROBAR-SV	page 255
<code>SYSPAR.ROBAR-CL.<ver>.PROZPARAM</code>	This file contains the internal parameters for execution control	page 259
<code>message_file</code>	This file contains all BS2000 and archive system messages relevant to ROBAR	page 260
<code>message_xref</code>	This file contains BS2000, ROBAR and archive system actions triggered by events specified in the <code>message_file</code> ¹	page 268
<code>message_resp</code>	This file contains among others the keywords for the BS2000 and ROBAR actions of the messages used in <code>message_xref</code>	page 273
<code>robarer_cmds</code>	This file contains the archive system commands used in <code>message_xref</code>	page 304
<code>error_defines</code>	This file contains actions to be taken in the event of an error ¹	page 307
<code>3590/message_xref</code>	Special file for devices of the type 3590E ²	
<code>TYPE-1/message_xref</code>	Special file for devices of the type LTO-Ux ²	

¹ This file contains the keywords for the ROBAR actions

² The different rule files allow ROBAR to take account of the specific device attributes (e.g. error handling) of the relevant device types

The RRFs are placed in the interface specific `message_storage` directory when ROBAR-SV is installed, see [page 202](#). When a ROBAR-SV instance is started, they are transferred to the `/var/lib/<interface>/<ROBAR-SV-Instance>/message_storage` directory together with the other files of the ROBAR-SV instance.

Several RRF sets are available:

- set `CentricStor` for ETERNUS CS
- Set `SCSI_1` for Scalar i500, i2000 and i6000

ROBAR is shipped with standard ROBAR rule files for both the BS2000 systems and the ROBAR server.

If the standard files do not cover all the requirements of your data center, you can modify them to suit the needs of your data center at your own responsibility before ROBAR is used for the first time, see [section "Modifications in the ROBAR rule files" on page 311](#).

7.1 Interrelationships between the files

7.1.1 BS2000 message - message_file

The BS2000 messages of relevance for the archive system are contained in the SYSPAR.ROBAR-CL.<ver>.MESSAGES file. This file contains the message numbers of the system messages that are to be forwarded by ROBAR-CL to ROBAR-SV, together with information on which message inserts are to be passed to ROBAR-SV.

Upon receipt of the messages transferred from ROBAR-CL, ROBAR-SV allocates a unique message key to each message transferred. This is done using the file `message_file` that contains all BS2000 messages of relevance for ROBAR and the archive system notification messages to be processed by ROBAR.

An entry in this `message_file` could look like this:

```
:*:MF000: %NKVT011 vvvvvv mmmm
```

Console message NKVT011 is assigned message code MF000. The VSN to be processed and the device mnemonic are passed at the same time.

Structure of the message code

The message code is 5-digit (MF000) and consists of the abbreviation MF, which identifies a console message, and a 3-digit message number. The message code enables the unique identification of any console message in the ROBAR system.

The message code, which is taken from `message_file`, is in turn used to specify in `message_xref` the actions to be executed by ROBAR.

7.1.2 message_file - message_xref

The file `message_xref` contains the same message code as `message_file`. In `message_xref` the message code is followed by 5-character action codes defining the actions to be executed by ROBAR. Processing steps and error handling can be defined by a separate syntax.

7.1.3 message_xref - roboter_cmds/message_resp

The actions to be executed are stored in one of two files:

Archive system actions are stored in `roboter_cmds` (action type RC), e.g.

```
:*:RC005:H '<####,EJ , ,FFFF,1,r, ,vvvvvv, ,AAAAAAA,BBBBBBBB,UUUUUUUU>'
```

Non-archive system actions are stored in `message_resp` (action type MR), e.g.

```
:*:MR760: TYPE % ROB7060 VOLUME EJECTED
(TSN=tttt / VSN=vvvvvv)
*:MR300: RESPONSE tttt.
```

Every action code has a 3-digit number suffixed to the action type (RC005, MR760, MR300).

Processing steps and error handling

In the `message_xref` file a number of actions can be defined for each message code.

Actions separated by ',' belong to the same processing step.

An archive system error code can be specified in angle brackets at the beginning of a processing step. In this case, control will branch to this processing step only if the corresponding error has occurred.

The end of a processing step is indicated by ';':

If an error occurs during the execution of an action, ROBAR-SV branches either to the processing step with the corresponding error code or to the next processing step without an error code.

Actions which are to be executed in the event of particularly serious errors, such as robot failure, are defined in the `error_defines` file. The keywords ATOP, EXIT and STOP are available for this purpose. They are described on [page 307](#).

Example

For a console message with the message code MF999 (for example):

```
:*:MF999: RC005,MR760,MR300;\
<N301>MR765,MR320;\
<N302>MR765,MR320;\
MR765,MR330
```

the following actions are to be executed:

1. Archive system action RC005
2. BS2000 actions MR760 and MR300

If both actions have been successfully executed, processing of the console message terminates here.

If the first action (RC005) is acknowledged by the archive system with error code N301 or N302, the actions following <N301> or <N302>, i.e. actions MR765 and MR320, are executed. If no error occurs, processing of the console message is complete.

All other negative acknowledgments will cause actions MR765 and MR330 to be executed.

7.1.4 Overview

The following example of a mount request outlines the steps followed by ROBAR in processing a console message, and also shows which files are used in the process:

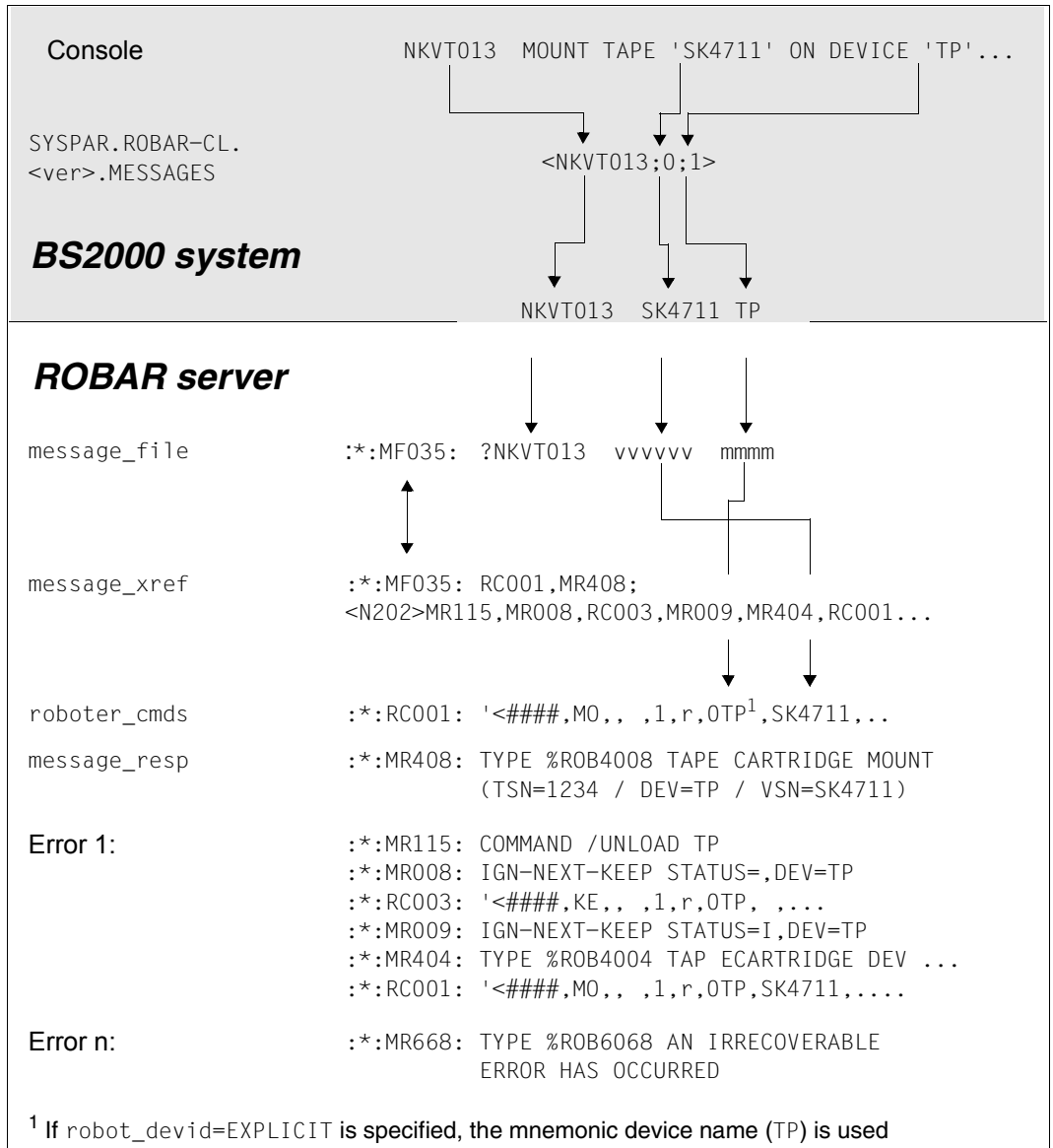

Figure 20: Example of processing of a console message by ROBAR

7.2 Description of the files



The contents of the ROBAR rule file depend of the archive system used and of the devices supported. For this reason, the contents of the ROBAR rule file illustrated here may differ from the ROBAR rule file shipped. You can also modify the ROBAR rule files to meet your specific requirements, see the [section “Modifications in the ROBAR rule files” on page 311](#).

Special characters in the files

All messages and actions in the ROBAR rule files must be written in uppercase letters. The lowercase letters `t, m, v, l, s, a, b, r, f, n, z, u` and the characters `#` and `/` have a special meaning in ROBAR. Wherever they occur in the message files, they are replaced by the text of the BS2000 message. This enables the following variables to be defined:

<code>tttt</code>	TSN
<code>mmmm</code>	Device mnemonic (2- or 4-character MN)
<code>vvvvvv</code>	VSN of the volume
<code>llllllll</code>	Storage location of the volume
<code>ss</code>	Archive system status byte (for manual command input only)
<code>aaaaaaaa</code>	Archive system coordinate, storing position for foreign cartridges, SUBTSN, or other content
<code>bbbbbbbb</code>	Archive system coordinate (for manual command input only), or other content
<code>r</code>	Robot number
<code>ffff</code>	Archive system-response
<code>####</code>	Sequence number of the ROBAR job (used internally)
<code>zzzzzzz</code>	Other information
<code>uuuuuuuuu</code>	Date and time in the format <code>dd/hhmmss</code>
<code>/</code>	Dummy character in <code>message_file</code> for insignificant text positions
<code>iii</code>	Logical input area
<code>eee</code>	Logical output area



Each group of these special characters may appear once only in a message. Successive identical special characters indicate the length of the variable, and the first occurrence of the special character indicates its position in the message.

The lengths of the variables `m, v, l, s, a, b, r, f, #, z, u, i, e` refer to the archive system commands or inserts of the BS2000 system messages. These lengths must be adhered to (see above).

*Example***BS2000 message:**

```
NKVT011 TAPE 'A0001K' DISMOUNTED FROM DEVICE 'T0'
```

Entry in message_file:

```
:*:MF000: %NKVT011 vvvvvv mmmm
```

Since the BS2000 message is identified uniquely by the message number `NKVT011`, certain text positions in ROBAR message can be dispensed with. All character strings consisting of uppercase letters, blanks and special characters are always checked.

In all actions which are executed by ROBAR for this message, the special characters `vvvvvv` and `mmm` are replaced with `A0001K` and `T0` respectively.

The TSN (`tttt`) is not given in `message_file` since it is determined internally.

7.2.1 File SYSPAR.ROBAR-CL.<ver>.MESSAGES

The BS2000 file SYSPAR.ROBAR-CL.<ver>.MESSAGES contains the message numbers of the console messages to be forwarded by ROBAR-CL to ROBAR-SV. The specified message inserts are extracted and transferred together with the message key to ROBAR-SV.

The file contains all message numbers currently required for robot operation. This also comprises the message numbers of DMS, HSMS/ARCHIVE and MAREN.

Structure of the entries

Comment lines always being with *.

Each entry begins in column 1 of the line and has the format:

```
<msg_no;insert_list;<mn_insert>>, z.B. <NKVT010;0;1;<1>>.
```

where:

msg_no

7-character message number of the BS2000 message

insert_list

List of insert numbers

The insert numbers correspond to the variable inserts in the BS2000 messages. In the BS2000 messages they are marked with (&nn) where nn = insert number. Several inserts may be specified and separated by ;. The inserts must be in ascending order.

mn_insert

The insert with the mnemonic device name (MN insert) is specially marked by the number of the MN insert being entered again in angle brackets at the end of the insert list.

<1> in the example above means that &01 is the MN insert. This enables the MN insert to be extracted from a message. This enables messages to be filtered before they are forwarded to ROBAR-SV.

ROBAR-CL maintains a table in which the MNs which are relevant for the connected ROBAR-SV instance are recorded. A message with an MN insert is forwarded to ROBAR-SV only if the MN insert is contained in the table of the MNs which are relevant for the connected ROBAR-SV instance.

Examples

The message NKVT011 TAPE '(&00)' DISMOUNTED FROM DEVICE '(&01)' is to be forwarded to ROBAR-SV.

The console output could look like this:

```
NKVT011 TAPE 'A0001K' DISMOUNTED FROM DEVICE 'GO'
```

The following entries would be permissible in SYSPAR.ROBAR-CL.<ver>.MESSAGES:

Format 1: <NKVT011;0;1<1>>

Format 2: <NKVT011;1<1>>

Format 3: <NKVT011;0>

The messages would be forwarded to the ROBAR server as follows:

Format 1: NKVT011 A0001K GO

Format 2: NKVT011 GO

Format 3: NKVT011 A0001K

Formats 1 and 2 are forwarded to ROBAR-SV only if GO is configured in the connected ROBAR-SV.

The following entries, for example, would be incorrect:

Format 4: <NKVT011;0,1>

Format 5: <NKVT011;1;0>

Format 6: <NKVT011;0;2>

In format 4 the inserts are not separated by ;.

In format 5 the inserts are not in ascending order.

In format 6 insert 2 was selected although the BS2000 message only contains insert 0 and insert 1.

Extract from the file SYSPAR.ROBAR-CL.<ver>.MESSAGES

```

*-----#
* Tape-Messages
*-----#
<NKVT010;0;1;<1>>
<NKVT011;0;1;<1>>
<NKVT012;0;1;<1>>
<NKVT013;0;1;2;3;6;<1>>
<NKVT014;0;1;2;<1>>
<NKVT017;1;<1>>
<NKVT018;0;1;<1>>
<NKVT024;0;<0>>
<NKVT046;0;1;<1>>
<NKVT053;0;1;<1>>
<NKVT075;0;1;<1>>
<NKVT077;0;1;<1>>
<NKVT097;0;1;<1>>
<NKVT098;0;<0>>
*
*-----#
* DETACH/ATTACH-Messages
*-----#
<NKR0040;0;<0>>
<NKR0045;0;<0>>
<NKR0046;0;<0>>
<NKR0048;0;<0>>
<NKR0097;0;<0>>
<NKR0110;0;<0>>
*
*-----#
* MAREN
*-----#
<MARUP44;0;1;<1>>
<MARM1IB;0;1;<1>>
<MARM1IA;1;2;<2>>
<MARM1RO;0;1;2>
<MARM1R2;0;<0>>
<MARM1S1;0;1>
*
*-----#
* ROBAR-CL-SDF-Statements
*-----#
<ROB1010;0;1>
<ROB1011;0;1>
<ROB1013;0;1;2;3>
<ROB1020;0>
<ROB1021;0;1;2>

```

```
<ROB1030;0;1;2>
<ROB1031;0;1;2>
<ROB1040;0;1;2>
<ROB1050;0;1;2;3>
*
*-----#
* Device-errors-Messages
*-----#
<EXC0858;0>
*
*-----#
* MIM-Messages
*-----#
<NJT0031;0>
*
*-----#
* DMS-Messages
*-----#
<DMS0591;1;2;3>
<DMS0DA3;0;1>
<DMS0DDB;0>
<DMS0DF7;0;1;<0>>
<DMS0DFB;0;3;<0>>
<DMS0DDE;0>
*
*-----#
* ARCHIVE-Messages
*-----#
<ARC0000;0>
<ARC0018>
<ARC0850;0>
<ARC0901;1>
<ARC0902;1>
<ARC0903;1>
<ARC0906;1>
<ARC0907;0>
<ARC0908;0;1>
*
<FDB4015;0>
***** END *****
```

7.2.2 File SYSPAR.ROBAR-CL.<ver>.PROZPARAM

In addition to internally-used parameters for the ROBAR system execution control, the BS2000 file SYSPAR.ROBAR-CL.<ver>.PROZPARAM contains the routing code for TYPE commands that are to be received from ROBAR-CL via \$CONSOLE.

```
*
* Routing code for SEND-MESSAGE commands
*
TypeRoutingcodes=T
*
*****
* Time between two ROBAR-SV requests, when the partner does not
* answer anymore (in seconds)
*
VerbUeberwachung=300
*
*****
* Maximum wait time (in seconds), when ROBAR-DCAM waits for a
* ROBAR-SV response.
*
VerbUeberwachungZeit=180
```

You can change the following entries using an editor:

TypeRoutingcodes=

List of routing codes in BS2000: types beginning with T are forwarded to ROBAR-SV.

VerbUeberwachung=

Length of time in seconds of monitoring period of connections between BS2000 systems and the ROBAR server.

VerbUeberwachungZeit=

Time in seconds for maximum runtime of response to the monitoring query (if there is no response, it is assumed that the connection has been severed).

7.2.3 File message_file

The file `message_file` contains all BS2000 messages and archive system notification messages relevant to ROBAR-SV. A maximum of 600 entries can be made in this file.

New BS2000 messages relevant to ROBAR-SV may be added to the file.

Structure of the entries

Each entry begins in column 1 of the line and has the format: `.*:MF###:PS?msgtext e.g.
.*:MF020: ?NKVT013 *SCRAT mmmm SPECIAL INIT T////////,VSN=vvvvvv.`

where

3-digit number of the message code.
This message code must be unique within the file. However, a BS2000 message may be repeated a number of times with different inserts if each has a different message code.
If the first character is a digit, the message code is reserved for the manufacturer.

P Priority identifier:
H: message with high priority
N or `_`: message with no priority
L: message with low priority
Prioritized messages are given preference during job processing; otherwise the FIFO (first in - first out) principle applies.

S Serialization indicator:
P: Parallel processing, simultaneous accessing of resources
`_`: Normal serialization

? Indicates whether the message requires a response:
?: message requires a response
%: message does not require a response
/: other message

`msgtext` Message text.
In the case of TYPE or PAUSE messages:
routing code and text (e.g. `<T MOUNT . . .`)

The message texts must always be written in uppercase letters.

The message text at positions that are not significant can be escaped by means of a slash (/).

The position and length of the VSN, device mnemonic, and possibly storage location should be indicated using the lowercase letters `v`, `m` and `l`. ROBAR-SV refers to the VSN, the device mnemonic, and the storage location name to determine whether ROBAR-SV itself is responsible for processing the message.

The maximum line length is restricted to 127 characters.

Comment lines always begin with /*.

Example

The following console message is to be processed by ROBAR:

```
NKVT012 PREMOUNT TAPE 'C05000' ON DEVICE 'T1'
```

The message could be added to `message_file` as follows, where `###` is the ROBAR message number:

```
:*:MF### ?NKVT012 vvvvvv mmmm
```

The following entry would be incorrect as the inserts are in the wrong order:

```
:*:MF### ?NKVT012 mmmm vvvvvv
```

Extract of the file message_file

```

/*****
/*
/* English notice
/*
/* 1. Init with MAREN or INIT
/*
/* - MF020 and MF028 allow tape initialisation with MARM1IB and NKVT013.
/* They are activated by default.
/* - MF024 and MF029 allow tape initialisation with MARM1IB only.
/* They are deactivated by default.
/*
/* With MAREN up to 8.0A, initialisation with INIT can be disabled by
/* activating MF024 and MF029 and deactivating MF020 and MF028
/*
/* For volume initialisation with MAREN 8.1 and up, the messages MF020 and
/* MF028 must be kept activated because MAREN uses NKVT013 for mount
/* requests for tape initialisation.
/*
/* 2. Working without MAREN
/* Optionally ROBAR can process the following scratch tape request:
/* - To process the NKVT013 MOUNT '*SCRAT' ON DEVICE 'mm'; (USE='DMS'...
/* activate the MF030 and MF830 messages.
/* - To process the DMS0591 ENTER VSN(S) FOR 1 PRIVATE TAPE TAPE-C5,
/* activate the MF819 message. If, for example, the customer has 3591
/* devices inside the robot system and 3590E devices outside, he could
/* use the freepool management of ROBAR for TAPE-C5 without influence
/* to unspecific requests for TAPE-C4. In case of a similar
/* configuration (type A inside the robot system, type B outside) the
/* type has to be changed to the entry MF819.
/* - To process the DMS0591 ENTER VSN(S) FOR 1 PRIVATE TAPE,
/* activate the MF820 message.
/*
/* 3. Volume ejection with MAREN
/* Standard : MF220 is activated - Database record is NOT deleted
/* Optional : MF221 - Database record IS lost
/*
/* 4. For ARCHIVE messages, the U routing code must be selected.
*****/

```

```

/*
:*:MF000: %NKVT011 vvvvvv mmmm
:*:MF004: %NKVT097 *UNKNO mmmm
:*:MF005: %NKVT097 vvvvvv mmmm
:*:MF007: %NKVT024 mmmm
:*:MF008:H %NKVT010 *UNKNO mmmm
:*:MF009:H %NKVT010 vvvvvv mmmm
:*:MF010:H ?NKVT012 vvvvvv mmmm
:*:MF017: %NKVT017 mmmm
:*:MF018:H %NKVT018 vvvvvv mmmm
/*
:*:MF020: ?NKVT013 *SCRAT mmmm SPECIAL INIT T////////,VSN=vvvvvv
:*:MF022: ?NKVT013 *SCRAT mmmm SPECIAL LIST T////////,VSN=vvvvvv
:*:MF023: ?NKVT013 vvvvvv mmmm SPECIAL LIST T
/*:MF024: ?NKVT013 *SCRAT mmmm SPECIAL INIT T////////,VSN=vvvvvv
:*:MF027: ?NKVT013 *SCRAT mmmm SPECIAL INIT T
:*:MF028: ?NKVT013 vvvvvv mmmm SPECIAL INIT T
/*:MF029: ?NKVT013 vvvvvv mmmm SPECIAL INIT T
:*:MF02A: ?NKVT013 vvvvvv mmmm SPECIAL FDDRL
:*:MF02B: ?NKVT013 vvvvvv mmmm SPECIAL
/*
:*:MF02F: ?NKVT013 vvvvvv mmmm ,( REASON : WRONG_VOLUME=*EMPTY
/*
/*:MF030: ?NKVT013 *SCRAT mmmm DMS
:*:MF031: ?NKVT013 *UNKNO mmmm
:*:MF032: ?NKVT013 *SCRAT mmmm
/*
:*:MF033: ?NKVT013 vvvvvv mmmm ,( REASON : VIRTUAL_DEVICE
:*:MF034: ?NKVT013 vvvvvv mmmm ,( REASON : WRONG_VOLUME
:*:MF035: ?NKVT013 vvvvvv mmmm
/*
:*:MF050: ?NKVT014 vvvvvv mmmm ,( REASON : MOVE_COMMAND
:*:MF051: ?NKVT014 vvvvvv mmmm ,( REASON : DEVICE_INOPERABLE
:*:MF052: ?NKVT014 vvvvvv mmmm ,( REASON : WRITE_PERMISSION_MISSING
:*:MF053: ?NKVT014 vvvvvv mmmm ,( REASON : NO_DEVICE_END
:*:MF054: ?NKVT014 vvvvvv mmmm ,( REASON : WRONG_VOLUME
:*:MF056: ?NKVT014 vvvvvv mmmm ,( REASON : I/O-ERROR: MOVE
:*:MF058: ?NKVT014 vvvvvv mmmm ,( REASON : POSITION_NOT_SAVED
:*:MF060: ?NKVT014 vvvvvv mmmm ,( REASON : POSITIONING_ERROR
:*:MF062: ?NKVT014 vvvvvv mmmm ,( REASON : NO_POSITION_INFORMATION
:*:MF065: ?NKVT014 vvvvvv mmmm ,( REASON : DEVICE_CHANGED_BY_SYSTEM
:*:MF070: ?NKVT014 vvvvvv mmmm
:*:MF079: /NKVT044 vvvvvv mmmm
:*:MF080: /NKVT046 vvvvvv mmmm
:*:MF081: /NKVT053 vvvvvv mmmm
:*:MF085: %NKVT075 vvvvvv mmmm
:*:MF086:H %NKVT077 vvvvvv mmmm
:*:MF087: /NKVT098 mmmm

```

```

/*
:*:MF100:H %NKR0045 mmmm
:*:MF101:H %NKR0046 mmmm
:*:MF102:H %NKR0048 mmmm
:*:MF103:H %NKR0097 mmmm
:*:MF104:H %NKR0110 mmmm
:*:MF105:H %NKR0040 mmmm
/*
:*:MF205: ?MARUP44 vvvvvv mmmm
:*:MF210: ?MARM1IB vvvvvv mmmm
:*:MF215: %MARM1IA vvvvvv mmmm
/*
:*:MF220: ?MARM1R0 vvvvvv 11111111 ROBTER.EJNR/PN
/*:MF221: ?MARM1R0 vvvvvv 11111111 ROBTER.EJNR/PN
:*:MF225: ?MARM1R0 vvvvvv 11111111 ROBTER.EJTR/PN
:*:MF230: ?MARM1R0 vvvvvv 11111111 ROBTER.EJRR/PN
:*:MF235: ?MARM1R0 vvvvvv 11111111
/*
/*
:*:MF250: %MARM1R2 mmmm
/*
:*:MF300: ?ROB1010 STD vvvvvv
:*:MF302: ?ROB1010 TSN vvvvvv
:*:MF304: ?ROB1011 STD vvvvvv
:*:MF306: ?ROB1011 TSN vvvvvv
:*:MF308: ?ROB1013 FOREIGN vvvvvv aaaaaa r
:*:MF310: ?ROB1020 TSN
:*:MF320: ?ROB1021 FOREIGN vvvvvv 11111111
:*:MF321: ?ROB1021 FOREIGN vvvvvv *NO
/*:MF322: ?ROB1021 FOREIGN vvvvvv LOCATION
:*:MF32Z: ?ROB1021 FOREIGN vvvvvv /
:*:MF330: ?ROB1030 vvvvvv r 11111111
:*:MF331: ?ROB1030 vvvvvv r *NO
/*:MF332: ?ROB1030 vvvvvv r LOCATION
:*:MF33Z: ?ROB1030 vvvvvv r /
:*:MF340: ?ROB1031 vvvvvv r 11111111
:*:MF341: ?ROB1031 vvvvvv r *NO
/*:MF342: ?ROB1031 vvvvvv r LOCATION
:*:MF34Z: ?ROB1031 vvvvvv r /
:*:MF350: ?ROB1040 OWN r 11111111
:*:MF351: ?ROB1040 OWN r *NO
/*:MF352: ?ROB1040 OWN r LOCATION
:*:MF35Z: ?ROB1040 OWN r /
/*
:*:MF360: ?ROB1050 *ALL *ALL 11111111 hhh
:*:MF361: ?ROB1050 *ALL *ALL *NO hhh
/*:MF362: ?ROB1050 *ALL *ALL LOCATION
:*:MF36Z: ?ROB1050 *ALL *ALL /

```



```

/*
:*:MF370: ?ROB1050 *ALL aaaaaa 11111111
:*:MF371: ?ROB1050 *ALL aaaaaa *NO
/*:MF372: ?ROB1050 *ALL aaaaaa LOCATION
:*:MF37Z: ?ROB1050 *ALL aaaaaa /
/*
:*:MF380: ?ROB1050 vvvvvv *ALL 11111111
:*:MF381: ?ROB1050 vvvvvv *ALL *NO
/*:MF382: ?ROB1050 vvvvvv *ALL LOCATION
:*:MF38Z: ?ROB1050 vvvvvv *ALL /
/*
/*
:*:MF500: /EXC0858 /////m m m m IVRQ////////////////////-TENSION LOSS-
:*:MF501: /EXC0858 /////m m m m IVRQ////////////////////-DRIVE RESET SWITCH
:*:MF502: /EXC0858 /////m m m m IVRQ////////////////////-DRIVE OFFLINE-
:*:MF503: /EXC0858 /////m m m m IVRQ////////////////////-TAPE LENGTH VIOLATION-
:*:MF504: /EXC0858 /////m m m m IVRQ////////////////////-UNLOAD CARTRIDGE-
:*:MF505: /EXC0858 /////m m m m IVRQ////////////////////-DEVICE INOPERABLE-
:*:MF50A: /EXC0858 /////m m m m IVRQ////////////////////-EQUIPMENT CHECK-
:*:MF50B: /EXC0858 /////m m m m IVRQ////////////////////-MEDIUM LENGTH ERROR-
:*:MF50C: /EXC0858 /////m m m m IVRQ////////////////////-MEDIUM REMOVED-
:*:MF50D: /EXC0858 /////m m m m IVRQ////////////////////-DEVICE INTERVENTION-
:*:MF50Z: /EXC0858 /////m m m m IVRQ
:*:MF510: /EXC0858 /////m m m m EQCH////////////////////-LOAD DISPLAY CHECK-
:*:MF511: /EXC0858 /////m m m m EQCH////////////////////-CU-FAILURE-
:*:MF51Y: /EXC0858 /////m m m m EQCH////////////////////-EQUIPMENT CHECK-
:*:MF51Z: /EXC0858 /////m m m m EQCH
:*:MF520: /EXC0858 /////m m m m INOP////////////////////-/////INOPERABLE OR
INCOMPATIBLE DUAL CONTROL UNIT
:*:MF52A: /EXC0858 /////m m m m INOP////////////////////-INOPERABLE CC=/-
:*:MF52Z: /EXC0858 /////m m m m INOP
:*:MF530: /EXC0858 /////m m m m LDCK////////////////////-RELOAD CARTRIDGE-
:*:MF53A: /EXC0858 /////m m m m LDCK////////////////////-LOAD CHECK-
:*:MF53B: /EXC0858 /////m m m m LDCK////////////////////-UNLOAD CHECK-
:*:MF54Y: ?EXC0858 /////m m m m READ
:*:MF54Z: %EXC0858 /////m m m m READ
:*:MF55Z: /EXC0858 /////m m m m SEQU
:*:MF56Z: /EXC0858 /////m m m m RAWR
:*:MF57Z: /EXC0858 /////m m m m EMPT
:*:MF58Z: /EXC0858 /////m m m m UNRC
:*:MF590: /EXC0858 /////m m m m DSEE////////////////////-DSEE FAILURE2-
:*:MF59A: /EXC0858 /////m m m m DSEE////////////////////-ERASE ERROR-
:*:MF5AZ: /EXC0858 /////m m m m IOER////////////////////-DEFECTIVE PATH SHOULD BE
REMOVED-
:*:MF5B0: /EXC0858 /////m m m m NINT////////////////vvvvvv//--0000000A1AF
:*:MF5BZ: /EXC0858 /////m m m m NINT
:*:MF5CZ: /EXC0858 /////m m m m RCNF
:*:MF5DZ: /EXC0858 /////m m m m CSBE

```

```

:*:MF5EZ: /EXC0858 //m/ EBM
:*:MF5FZ: /EXC0858 //m/ BUSY
:*:MF5GZ: /EXC0858 //m/ NAIN
:*:MF5HZ:H /EXC0858 //m/ CLRQ
:*:MF5IZ: /EXC0858 //m/ OVER
/*
:*:MF600: /EXC0858 //m/ CUTE//////////--VOLUME FENCED-
:*:MF61Z: /EXC0858 //m/ IDCK
:*:MF630: /EXC0858 //m/ BOPE//////////--DEFECTIVE PATH SHOULD BE
REMOVED-
/*
:*:MF700: /EXC0858 //m/ ////////////--DEVICE FENCED-
:*:MF701: /EXC0858 //m/ ////////////--DEVICE-PATH FENCED-
:*:MF710: /EXC0858 //m/ ALRS//////////--ALLEGIANCE RESET-
:*:MF72Z: /EXC0858 //m/ BOEX
:*:MF73Z: /EXC0858 //m/ CALG
:*:MF740: /EXC0858 //m/ CMDR//////////--COMMAND REJECT-
:*:MF750: /EXC0858 //m/ COEX//////////--CONFIGURATION ERROR-
:*:MF76Z: /EXC0858 //m/ DTCK
:*:MF770: /EXC0858 //m/ EODM//////////--END OF DATA-
:*:MF78Z: /EXC0858 //m/ EXEX
:*:MF79Z: /EXC0858 //m/ IFCK
:*:MF7AZ: /EXC0858 //m/ LIBE
:*:MF7BZ: /EXC0858 //m/ NASG//////////--ASSIGNED ELSEWHERE-
:*:MF7CZ: /EXC0858 //m/ NCAP
:*:MF7EZ: /EXC0858 //m/ PREX
:*:MF7FO: /EXC0858 //m/ PROT//////////--PROTECTION EXCEPTION-
:*:MF7F1: /EXC0858 //m/ PROT//////////--WRITE PROTECT-
:*:MF7GZ: /EXC0858 //m/ RSET
:*:MF7H0: /EXC0858 //m/ UATT//////////--MEDIA INFORMATION
MESSAGE-
:*:MF7H1: /EXC0858 //m/ UATT//////////--I/O SUBSYSTEM SIM-
:*:MF7H2: /EXC0858 //m/ UATT//////////--DEVICE SIM-
:*:MF7H3: /EXC0858 //m/ UATT//////////--MEDIUM REMOVED-
:*:MF7HZ: /EXC0858 //m/ UATT
:*:MF7I0: /EXC0858 //m/ WREJ
/*
:*:MF800: P?DMSODA3 vvvvvv
:*:MF810: ?DMSODF7 mmmm vvvvvv
/*:MF819: ?DMS0591 1 TAPE TAPE-C5
/*:MF820: ?DMS0591 1 TAPE
/*:MF830: ?DMSODFB mmmm vvvvvv
:*:MF840: P?DMSODDB vvvvvv
/*
:*:MF850: %ARC0000 aaaa
:*:MF855: %ARC0018
:*:MF861: P?ARC0901 vvvvvv
:*:MF862: P?ARC0902 vvvvvv

```

```

:*:MF863: P?ARC0903 vvvvvv
:*:MF864: P%ARC0904 vvvvvv
:*:MF865: %ARC0905
:*:MF866: P?ARC0906 vvvvvv
:*:MF867: P?ARC0907 ////
:*:MF868: P?ARC0908 //// vvvvvv
/*
:*:MF900: %<T DEV mmmm NOTENTLADEN
:*:MF903: %<T E/A-BOX LEER
:*:MF904: %<T I/O-BOX EMPTY
:*:MF910: %<T DEVICE mmmm REPAIRED
:*:MF915: %<T VOLUME vvvvvv REPAIRED
/*
:*:MFOKE: ROBAR-KEEP vvvvvv mmmm
/*
:*:MFSAT: START-ATT mmmm
:*:MFSKE: START-KEEP mmmm
:*:MFSOC: START-OCCUPIED mmmm
:*:MFSMT: START-EMPTY mmmm
:*:MFSER: START-ERROR mmmm
/*
:*:MFXNR: <////,////,/,EXIT,N,/,///,////,/,/,////////,////////,uuuuuuuu>
:*:MFXIT: <////,////,/,EXIT,/,/,///,////,/,/,////////,////////,uuuuuuuu>
/*
:*:MFN00: <ASYN,NTFY,M,1300,/,r, ,vvvvvv,/,E, , ,uuuuuuuu>
:*:MFN01: <ASYN,NTFY,M,1301,/,r,aaa, ,bb, , ,uuuuuuuu>
:*:MFN09: <ASYN,NTFY,M,1309,/,r,Dmm, , , ,uuuuuuuu>
:*:MFN10: <ASYN,NTFY,M,1310,/,r,Dmm,vvvvvv, ,////////, ,uuuuuuuu>
:*:MFN11: <ASYN,NTFY,M,1311,/,r,Dmm,vvvvvv, ,aaaaaaaa, ,uuuuuuuu>
:*:MFN12: <ASYN,NTFY,M,1312,/,r,aaa, , , ,uuuuuuuu>
:*:MFN14: <ASYN,NTFY,M,1314,/,r, ,vvvvvv, ,////////,////////,uuuuuuuu>
:*:MFN15: <ASYN,NTFY,M,1315,/,r, ,vvvvvv, ,////////,////////,uuuuuuuu>
:*:MFN30: <ASYN,NTFY,M,0930,/,r,aaa, , , ,uuuuuuuu>
:*:MFN34: <ASYN,NTFY,M,1334,/,r, , , , ,uuuuuuuu>
:*:MFN35: <ASYN,NTFY,M,1335,/,r, , , , ,uuuuuuuu>
:*:MFN36: <ASYN,NTFY,M,1336,/,r, , , , ,uuuuuuuu>
:*:MFN37: <ASYN,NTFY,M,1337,/,r,hhh, , , ,uuuuuuuu>
:*:MFN38: <ASYN,NTFY,M,1338,/,r, , ,ss, , ,uuuuuuuu>
:*:MFN39: <ASYN,NTFY,M,1339,/,r, , , , ,uuuuuuuu>
:*:MFN40: <ASYN,NTFY,M,1340,/,r, , , , ,uuuuuuuu>
:*:MFN95: <ASYN,NTFY,M,1195,/,r,aaa, ,bb, , ,uuuuuuuu>
:*:MFN97: <ASYN,NTFY,M,1297,/,r, , ,OF, , ,uuuuuuuu>
:*:MFN98: <ASYN,NTFY,M,1298,/,r, , ,ON, , ,uuuuuuuu>
:*:MFN99: <ASYN,NTFY,M,1299,/,r, ,vvvvvv,/,B, , ,uuuuuuuu>
:*:MFN50: <ASYN,NTFY,M,5000,/,r, , , , ,uuuuuuuu>

```

7.2.4 File message_xref

The `message_xref` file defines the actions which are to be triggered by the messages (defined in the file `message_file`). The entries are linked through the ROBAR message code `MF###`.

A maximum of 600 entries can be made in this file.

The codes of the archive system or BS2000 actions to be executed by ROBAR must be specified in this file for every BS2000 message. The actions must be separated by `,` or `;`; `;` defined the end of processing. An archive system error code can be specified in angle brackets at the beginning of a processing step. Control branches to the processing step only if the corresponding error occurs.

Structure of the entries

Each entry begins in column 1 of the line and has the format: `:*:MF###: msgno, . . . , e.g. <STA8>MR080,MR525;\ .`

where

`###` 3-digit number of the message code

Message code of the message, defined in `message_file`, for which the specified actions are to be executed

`m1dnr` Action code of action to be executed.

`RC###` Archive system command (see [page 304](#))

`MR###` ROBAR action (see [page 273](#))

`<CHGT>` Device to be mounted is not ATTACHED and ASSIGNED

`<DOUB>` Tape initialization: allocation not unique

`<DVDT>` Device is detached,
robot actions are no longer possible for this device

`<DVER>` The device error limit has been reached

`<DVMT>` The device is empty, no KE possible
(as a result of the `SKIP-IF-EMPTY / GET-VSN` command)

`<DVOC>` The device is occupied (as a result of the `SKIP-IF-OCCUPIED` command)

`<DVSNI>1` VSN in freepool not unique

`<ECON>1` Inconsistency when creating / deleting the TSN freepool

`<EEXT>1` Foreign file already exists

`<EOPNI>1` Freepool file/foreign file cannot be opened

`<EREMI>1` Error when deleting freepool file

<ERF0>	Internal error in the foreign cartridge definition
<ESYN> ¹	Syntax error in VSN specification
<ETSN> ¹	Error while deleting the foreign file with TSN reference / TSN freepool does not exist
<EVSN> ¹	Error when deleting foreign file with VSN reference / VSN for freepool in ROBAR_ARCHIV not known
<FPMT>	Freepool is empty, no freepool allocations possible
<INIT>	MTC initialization by the INIT utility (cartridge is not yet mounted)
<MAR5>	Tape initialization using MAREN (cartridge is already mounted)
<MDEV>	Processing step for devices to be operated manually
<Nxxx>	Archive system error code
<NDF0>	End of foreign cartridge definition (GET_FOREIGN INDEX=hhh)
<NOAS>	No cartridge is allocated to this foreign cartridge storing position (GET_FOREIGN POSITION=aaaaaa) or there is no cartridge with the specified archive number (GET_FOREIGN VOLUME=vvvvvv)
<NOF0>	The ROBAR_FOREIGN.<instance> file does not exist
<NOHO>	There is currently no server (host) defined (as a result of the RESPONSE / GET-HOST command)
<NOTS>	No TSN has a cartridge in the device (as a result of the GET-TSN command)
<RCLN>	Error in cleaning job
<VVER>	The volume error limit has been reached

¹ Action code only occurs in conjunction with ROBAR-CL-SDF messages.

Comment lines always begin with /*. The length of an entry is restricted to 2000 characters. If a line ends with \, the next line is interpreted as a continuation line. Up to 40 continuation lines are permitted.

Furthermore, branch destinations which the user can select freely can be defined using the TEST-FIELD keyword.

Extract from the file message_xref

```
/*
:* :MF000:
MR07I,MR08F,MR08G,MR078,MR079,MR070,MRV01,RC003,MR069,MR08B,MR08J,MR08P,MR404
,MR010,MR086,MR07A,\
MR077,MR071,MR096,MR081,MR07H;\
<N206>RC003,MR069,MR08B,MR08J,MR08P,MR404,MR010,MR086,MR07A,MR077,MR071,MR096
,MR081,MR07H;\
<STA0>MR080,RC003,MR069,MR08B,MR08J,MR08P,MR404,MR010,MR086,MR07A,MR077,MR071
,MR096,MR081,MR07H;\
<N206>MR115,MR215,RC003,MR069,MR08B,MR08J,MR08P,MR404,MR010,MR086,MR07A,MR077
,MR071,MR096,MR081,MR07H;\
<N206>MR07D,MRV13,MR115,MR815,MRVF3,RC003,MR069,MR08B,MR08J,MR08P,MR820,MR07A
,MR077,MR071,MR096,MR081,MR07H;\
<N206>MRVG3,RC003,MR069,MR08B,MR08J,MR08P,MR820,MR07A,MR077,MR071,MR096,MR081
,MR07H;\
<N112>RC003,MR069,MR08B,MR08J,MR08P,MR404,MR010,MR086,MR07A,MR077,MR071,MR096
,MR081,MR07H;\
<N112>MR033,MR183,MR202,MR02A,MRV22,MRV23,MR525,MR093,MR962,MR960,MR061,MR09A
,MR09B;\
<N206>MR033,MR183,MR202,MR02A,MRV22,MRV23,MR525,MR093,MR962,MR960,MR061,MR09A
,MR09B;\
<N203>MR069,MR08B,MR08J,MR024,MR096,MR081,MR07H;\
<N205>MR069,MR08B,MR08J,MR024,MR096,MR081,MR07H;\
<N101>RC003,MR069,MR08B,MR08J,MR08P,MR404,MR010,MR086,MR07A,MR077,MR071,MR096
,MR081,MR07H;\
<N101>MR182,MR611;\
<N208>RC003,MR069,MR08B,MR08J,MR08P,MR404,MR071,MR096,MR081;\
<N208>MR033,MR505,MR183,MR202,MR02A,MRV22,MRV23,MR525,MR093,MR962,MR960,MR061
,MR09A,MR09B;\
<STA8>MR080,MR525;\
<STA9>MR080;\
<N304>MRV54,MR096,MR081,MR07H;\
<STAA>MR08A,MR062,MR072;\
<STA7>MR087,MR062,MR072;\
<STAI>MR200;\
<STA1>MR09A,MR09B,MR07H;\
<DVMT>MR092,MR960,MR061,MR09B,MR07H;\
<DVER>MR669,MRV24,MR180;\
<VVER>MR09B,MR670,MRV25,MR181,MR072;\
<DVER>MR670,MRV25,MR181,MR669,MRV24,MR180,MR072;\
<STA2>MR082,MR04A,MR14E,RC038,MR14B,MR720;\
<SSOC>MR011,MR141,MR142,RC039,MR097;\
<NORM>MR011,MR097;\
<NOFO>RC005,MR097,MR760;\
<NOAS>RC005,MR097,MR760;\
<N308>MR762;\
```

```
<N309>MR200;\
<STA>RC004,MR089,MRVA3,RC022,MR045,MR069,MR418,MR08H;\
<N700>MR422;\
<RCLN>MR200;\
<DVDT>MR200;\
<N004>MR182,MR505;\
<N005>MR182,MR505;\
<N006>MR182,MR505;\
<N008>MR182,MR505;\
<N009>MR182,MR505;\
<N011>MR184,MR511;\
<N015>MR182,MR505;\
<N016>MR182,MR505;\
<N017>MR182,MR505;\
<N100>MR182,MR505;\
<N102>MR182,MR505;\
<N103>MR182,MR505;\
<N104>MR182,MR614;\
<N105>MR182,MR505;\
<N501>MR182,MR505;\
<N503>MR200;\
MR406
/*
:*:MF004:
MR07I,MR086,MR08F,MR08G,MR078,MR079,MR074,MR070,MRV01,MR077,RC003,MR069,MR08B
,MR08J,MR08P,MR404,\
MR071,MR095,MR081,MR07H;\
<STA7>MR033,RC003,MR069,MR08B,MR08J,MR08P,MR404,MR087,MR062,MR072;\
<N206>RC003,MR069,MR08B,MR08J,MR08P,MR404,MR077,MR071,MR095,MR081,MR07H;\
<STA0>MR080,RC003,MR069,MR08B,MR08J,MR08P,MR404,MR077,MR071,MR095,MR081,MR07H
;\
<N206>MR07D,MRV13,MR115,MR815,MRV3,RC003,MR069,MR08B,MR08J,MR08P,MR820,MR077
,MR071,MR095,MR081,MR07H;\
<N206>MRV3,RC003,MR069,MR08B,MR08J,MR08P,MR820,MR077,MR071,MR095,MR081,MR07H
;\
<N112>RC003,MR069,MR08B,MR08J,MR08P,MR404,MR077,MR071,MR095,MR081,MR07H;\
<N112>MR033,MR183,MR202,MR02A,MRV22,MRV23,MR525,MR092,MR960,MR061,MR09B;\
<N206>MR033,MR183,MR202,MR02A,MRV22,MRV23,MR525,MR092,MR960,MR061,MR09B;\
<N203>MR069,MR08B,MR08J,MR024,MR095,MR081,MR07H;\
<N205>MR069,MR08B,MR08J,MR024,MR095,MR081,MR07H;\
<N101>RC003,MR069,MR08B,MR08J,MR08P,MR404,MR077,MR071,MR095,MR081,MR07H;\
<N101>MR182,MR611;\
<N208>RC003,MR069,MR08B,MR08J,MR08P,MR404,MR071,MR095,MR081;\
<N208>MR033,MR505,MR183,MR202,MR02A,MRV22,MRV23,MR525,MR092,MR960,MR061,MR09B
;\
<STA8>MR080,MR525;\
<STA9>MR080;\
<STA4>MR200;\
```

<N304>MRV54,MR07H;\

<STA7>MR087,RC005,MR760;\

<STAD>MR080,MR525;\

<STAI>MR200;\

<STA1>MR09B,MR07H;\

<DVMT>MR092,MR960,MR061,MR09B,MR07H;\

<DVER>MR669,MRV24,MR180;\

<STAH>RC004,MR089,MRVA3,RC022,MR045,MR069,MR418,MR08H;\

<N700>MR422;\

<RCLN>MR200;\

<DVDT>MR200;\

<N004>MR182,MR505;\

<N005>MR182,MR505;\

<N006>MR182,MR505;\

<N008>MR182,MR505;\

<N009>MR182,MR505;\

<N011>MR184,MR511;\

<N015>MR182,MR505;\

<N016>MR182,MR505;\

<N017>MR182,MR505;\

<N100>MR182,MR505;\

<N102>MR182,MR505;\

<N103>MR182,MR505;\

<N104>MR182,MR614;\

<N105>MR182,MR505;\

<N501>MR182,MR505;\

<N503>MR200;\

MR185,MR668

...

7.2.5 File message_resp

The `message_resp` file contains both BS2000 and ROBAR actions. The individual actions are defined using keywords. A maximum of 600 entries can be made in this file.



The message class `ROBxxxx` of the file `message_resp` is reserved for the manufacturer.

The following three different adjustable waiting times can be specified in the file:

- wait before normal KEEP (`MRV01`)
The selected value for the waiting time (in seconds) should be as close as possible to the average rewind time (note that the average rewind time (default case and emergency unload) depends on the cartridges and the MTC device type used). The defined waiting time can range from “0” (no modification in terms of the ROBAR predecessor version) to the maximum rewind time (the robot is never blocked by a KEEP operation, the relevant MTC device and MTC are not, however, available for a long period of time). The recovery procedure is introduced (see next point) if the subsequent KEEP operation fails as a result of a timeout action initiated by the robot (e.g. with MTC device problems).
- wait between ULU and KEEP (`MRVFi` and `MRVGi`)
The value selected for the waiting time (in seconds) for `MRVFi` should come as close as possible to the average rewind time. If 0 is set, the robot is immediately blocked by a KEEP operation. The maximum value that can be set matches the maximum exceptional rewind time (the robot is never blocked by a KEEP operation, the relevant MTC device and MTC are not, however, available for a long period of time). In short, if ROBAR discovers that a KEEP operation will be canceled as the result of a timeout, a subsequent KEEP operation (`MRVGi`) increases the waiting time.

The following table gives the default values for waiting times. If the values are changed, ensure that the total waiting time which is made up of the two waiting times is not changed.

MTC device	3590E	LTO-Ux	ETERNUS CS
<code>MRVF_i</code> ¹	180 sec.	180 sec.	0 sec.
<code>MRVG_i</code> ¹	60 sec.	60 sec.	0 sec.

¹ `i = 2`: for device type 3590E; `i = 3`: for device type LTO-Ux;
`i = 4`: for ETERNUS CS (only for reasons of consistency; not used as no cleaning procedures are required for ETERNUS CS).

- waiting time for the cleaning action (MRVA_i)
Time required for a cleaning action (period from insertion of the cleaning cartridge into the MTC device until the point when it is removed automatically from the MTC device).

MTC device	3590E	LTO-Ux	ETERNUS CS
MRVA _i ¹	35 sec.	140 sec.	0 sec.

¹ i = 2: for device type 3590E; i = 3: for device type LTO-Ux;
i = 4: for ETERNUS CS (only for reasons of consistency; not used as no cleaning procedures are required for ETERNUS CS).

Structure of the entries

Each entry begins in column 1 of the line and has the format:

```
:*:MR###: key aktop
```

Example

```
:*:MRV01: WAIT    0
```

where

3-digit number of the action code
 This action code must be **unique** within the file.

key Keyword, beginning in column 12

aktop Action operand, beginning in column 25

Comment lines always begin with /*. The maximum line length is restricted to 250 characters. If a line ends with \, the next line is interpreted as a continuation line. Only one of these continuation lines is permitted.



If you make changes to the file `message_resp`, ensure that the structure and order of the entries is retained. In particular, if you are adding action operands, you should make certain that they begin in column 25.

Keywords

The individual actions are explicitly defined by means of keywords. Each keyword may be followed by one or more action operands, beginning in column 25. The action operands are permanently assigned (except for those marked ¹) and must not be changed (an individual explanation of the keywords is given after the table).

Keyword	action
ALLOW-PARALLEL-PROCESSING	Allow parallel processing for resources (MTC device, MTC)
ASYNC	Asynchronous processing
CHECK	Check the device and the volume error counters and their limits
CHK-DEVSTAT	Query status byte
CHK-RESPSWI	Ignore subsequent actions in <code>message_xref</code>
CLEAN-DEV	Set the cleaning counter to the value at which the cleaning operation takes place
COMMAND ¹	Enter operator command
DECLARE	Manage subtasks
DELETE-SUBTASK	Remove subtask
DISCARD_MSG	Discard obsolete messages from the message queue (<code>cmx/robar.mess</code> file)
EJECT-CONT	List of EJECT requests previously rejected due to the input/output unit being full
EMPTY-DEV	Set device logically to empty
GET_DEVSTAT	Query user status byte
GET_FOREIGN ²	Get information from the <code>ROBAR_FOREIGN.<instance></code> file
GET_HOST	Query the identity of the server to which the device is connected
GET_MAINTASK	If <code>DECLARE SUBTASK</code> was previously issued for the sub TSN, the TSN of the corresponding main task is stored in the variables <code>aaaa</code> . Otherwise the value of <code>tttt</code> is stored in the variables.
GET_TSN	Assign an internal variable field the TSN that initiated mounting of the data medium
GET_VSN	Assign an internal variable field the archive number of the mounted data medium
IGN-NEXT-KE	Ignore next <code>KEEP</code>
MAREN-INIT	Search devices for requested VSN
PAUSE ¹	Display message text on BS2000 console with operator response
PROCESS-OFFLINE	Cancel online processing of a notification message
RE-ENTER	Re-enter the current message in the message queue

Keyword	action
READ-BARCODE	Preset barcode evaluation for subsequent M0 and EJ commands
READ-CONFIG	Reread the configuration file and update its status
RECORD	Write text to error logging file or change error counter
RELEASE ²	Release freepool files and foreign cartridges
REPEAT	Pend job
RESET-DEVSTA	Reset device status byte
RESET-MOUNT-COUNTER	Reset counter for MTC mount operations
RES_DEVSTAT	Reset user status byte
RESPONSE ¹	Respond to BS2000 message
RESUME-ROBOT-PROCESSING	Switch the robot that is currently inactive to "ON" mode logically
ROBAR-FPOOL	Withdraw next free VSN from freepool
ROBAR-MESS	Define type of ROBAR error message
ROUTINGCODE	Routing code of SEND-MESSAGE command
SET-DEVSTAT	Set device status byte
SET_DEVSTAT	Set user status byte
SET-FIELD	Define the value of an RRF variable for BS2000 or archive system command
SET_HOST	Modify the target location of subsequent TYPE, PAUSE or COMMAND commands
SINIX-SYSTEM ¹	Execute system command
SKIP-IF-EMPTY	Branch to <DVMT> if device empty
SKIP-IF-OCCUPIED	Branch to <DVOC> if device occupied
SUSPEND-ROBOT-PROCESSING	Switch the robot that is currently active to "OFF" mode logically
SWITCH-CONNECTION	Use an alternative address as the connection address at the next start of ROBAR-SV
TEST-FIELD	Compare internal variable field with the defined value
TYPE ¹	Display message text on BS2000 console
UPD-VOLMGR	Transfer information relating to data media to BS2000 MAREN system
UPDCONF	Record device allocation to BS2000 hosts
WAIT ¹	Wait time in seconds

¹ The action operand must be specified by the user

² This statement is obsolete

ALLOW-PARALLEL-PROCESSING**Allow parallel processing for resources (MTC device, MTC) (multiprocessing)**

This instruction allows you to release resources involved in the current (MTC device or cartridge) request. Thereby allowing the parallel processing of a further request that accesses the same resources.

The configuration cannot be changed once the statement has been executed.

Action operands:	none
------------------	------

ASYNC**Asynchronous processing**

This keyword generates a further ROBAR process which executes the following ROBAR actions for the BS2000 message about to be processed. In a processing step **no** robot actions may be defined after this keyword. Generally you should specify this keyword only prior to relatively long `WAIT` statements..

Action operands:	none
------------------	------

CHECK**When the defined maximum number of errors has been reached, go to branch destination**

Action operands:	ERRCNT, VSN=vvvvvv	Go to branch destination <VVER> when the error counter in the configuration file has reached the number of errors specified in <code>volume_error_limit</code>
	ERRCNT, DEV=mmmm	Go to branch destination <DVER> when the error counter in the configuration file has reached the number of errors specified in <code>device_error_limit</code>

CHK-DEVSTAT**Query status byte**

The DETACH identifier for the specified device is checked in the configuration file (see SET-DEVSTAT). If the DETACH identifier is set, the next action defined in the message_xref file (see [page 268](#)) is executed. If the DETACH identifier is not set, a branch is made to the action after the next ';'.

Action operands:	STATUS=DETACH,DEV=mmmm
------------------	------------------------

CHK-RESPSWI**Ignore subsequent actions in message_xref**

You can use CHK-RESPSWI to control responses to non-specific volume requests. If a MTC is removed from the ROBAR freepool in response to a non-specific volume request, the actions after CHK-RESPSWI are executed. Otherwise, processing of the job concludes here.

Action operands:	none
------------------	------

CLEAN-DEV**Initiate mounting of the cleaning cartridge after the next MOUNT CLEAN request**

When certain actions have been executed on a device, it may be necessary to clean the device immediately afterwards. CLEAN-DEV sets the mount counter so that the cleaning cartridge is mounted for the next MOUNT CLEAN request.

Action operands:	DEV=mmmm
------------------	----------

COMMAND**Enter operator command**

This enables a BS2000 console command to be issued from ROBAR.

Action operands:	BS2000 console command (to be specified by the user)
------------------	--

Example

:*:MR110:	COMMAND	/UNLOAD mmmm
-----------	---------	--------------

DECLARE**Manage foreign and *SCRATCH cartridges, and subtasks**

The keyword `DECLARE` is used to

- manage the ROBAR freepool files,
- pass the positions of foreign cartridges in the output chutes to ROBAR, and
- assign subtasks to the user tasks.

Action operands:	<code>FREEPool-TSN</code>	(task-spec. ROBAR freepool)
	<code>FREEPool-STD</code>	(standard freepool)
	<code>FOREIGN-TAPE</code>	(foreign cartridges)
	<code>SUBTASK, TSN=tttt, SUBTSN=aaaa</code>	(subtasks)

DELETE-SUBTASK**Remove subtask**

You can use this keyword to remove a subtask generated using `DECLARE SUBTASK`.

Action operands:	<code>SUBTASK, SUBTSN=tttt</code>
------------------	-----------------------------------

DISCARD_MSG**Discard obsolete messages from the message queue**

This keyword allows you to discard obsolete messages from the message queue (cmx/robar.mess file). At least one operand has to be specified. vvvvvv and mmmm must not be switched, because they are dynamically replaced by the current contents of the variables vvvvvv and mmmm. If PATTERN= is specified, <text> must be replaced by freely selectable text (maximum 64 characters). The specifications define the criteria according to which messages are deleted from the message queue, i.e. a message is deleted when all of the specified criteria are fulfilled.



Use the DISCARD_MSG statement with the greatest of care, since it might otherwise produce undesirable side effects.

Action operands:	DEV=mmm	The messages that refer to the device with the current mnemonic device name mmmm are removed from the message queue
	VSN=vvvvv	The messages that refer to the archive number vvvvv are removed from the message queue
	PATTERN=<text>	The messages that contain the character string <text> are removed from the message queue

Example

```
DISCARD_MSG DEV=mmm,VSN=D12558,PATTERN=EXC0858
```

All messages in the message queue that refer to archive number D12558 and the device with the current mnemonic device name mmmm and that contain the character string EXC0858 are marked as obsolete. ROBAR ignores any error messages for the device that occurred before the statement was issued.

EJECT-CONT**Continue EJECT requests**

A list of cartridges to be removed from the archive system could not be fully processed due to an input/output unit being full. The keyword EJECT-CONT is used to resume processing of this list once the input/output unit is emptied.

Action operands:	none
------------------	------

EMPTY-DEV**Set device logically to empty**

This keyword is required if the archive system returns a negative acknowledgment for device unloading and also the error code N203 (device empty, determined by the archive system), N205 (device empty, determined by the robot), N504 (cartridge in the problem box) or N505 (cartridge store full). The device is actually physically free, but is logically occupied as far as ROBAR is concerned. `EMPTY-DEV` sets this device to logically free. ROBAR then behaves as if a positive acknowledgment had been returned for the `KEEP` command.

Action operands:	DEV=mmmm
------------------	----------

GET_DEVSTAT**Query user status byte**

The status byte (n = 0 ... 9 a ... z) set using `SET_DEVSTAT` is checked for the specified device. If the status byte is set, processing is resumed at the point at which the action with the status `<STAn>` is marked in the `message_xref` file.

If the status byte is not set, processing is resumed normally.

Action operands:	DEV=mmmm, STATUS=n
------------------	--------------------

GET_FOREIGN**Query user status byte**

This statement gets information from the `ROBAR_FOREIGN.<instance>` file for a specific foreign cartridge (`VOLUME`), a foreign cartridge in a specific foreign cartridge storing position (`POSITION`) or a cartridge identified via `INDEX`.

In the case of an error, the error reason is displayed in the following format:

<NOFO> **The ROBAR_FOREIGN.<instance> file does not exist**
 <NOAS> **No cartridge is allocated to this foreign cartridge storing position (GET_FOREIGN POSITION=aaaaaa) or there is no cartridge with the specified archive number (GET_FOREIGN VOLUME=vvvvvv)**
 <NDF0> **End of foreign cartridge definition (GET_FOREIGN INDEX=hhh)**
 <ERF0> **Error in the foreign cartridge definition**

Action operands:	VOLUME=vvvvvv
	POSITION=aaaaaa
	INDEX=hhh

GET_HOST**Query the identity of the server to which the device is connected**

Execution of this instruction is currently triggered, when the notification handler reports the beginning or end of a cleaning procedure. ROBAR finds out to which BS2000 system the device belongs. This allows subsequent instructions or the TYPE, PAUSE or COMMAND commands to be forwarded to the BS2000 system administering the device. If the device that is referenced in this instruction is not connected to a BS2000 system or if no device is specified in the message, the system branches to <NOHO> when the instruction is issued.

Action operands:	DEV=mmmm
------------------	----------

GET-MAINTASK**Output value defined using DECLARE SUBTASK**

If DECLARE SUBTASK was previously issued for the sub TSN, the TSN of the corresponding main task is stored in the variables aaaa. Otherwise the value of tttt is stored in the variables.

Action operands:	MAINTASK, SUBTSN=tttt
------------------	-----------------------

GET_TSN**Assign an internal variable field the TSN that initiated mounting of the data medium**

The internal variable field tttt is assigned the TSN that initiated mounting of a data medium on the device mmmm. If no TSN is available, the field remains empty and the system branches to the <NOTS> exit.

Action operands:	DEV=mmmm
------------------	----------

GET_VSN**Assign an internal variable field the archive number of the mounted data medium**

The internal variable field vvvvvv is assigned the archive number of the data medium mounted on the device mmmm. If no data medium is mounted, the field remains empty and the system branches to the <DVMT> exit.

Action operands:	DEV=mmmm
------------------	----------

IGN-NEXT-KE

Ignore next KEEP

If ROBAR executes an UNLOAD-TAPE and subsequent KEEP as its actions, this keyword causes the next KEEP for this device to be ignored as a result of the BS2000 message NKVT011 or NKVT097.

Action operands:	STATUS=I , DEV=mmmm	(KEEP is ignored only if the VSN of the mounted MTC is not the same as the VSN in the BS2000 message.)
	STATUS=N , DEV=mmmm	(The next KEEP for this device is always ignored)
	STATUS=_ , DEV=mmmm	(Reset status "ignore next KEEP")

MAREN-INIT

Search devices for requested VSN

When initializing an MTC, there is a distinction between initializing using the INIT utility and using MAREN. If MAREN is used, the MTC is initialized and mounted. If INIT is used, the MTC is initialized but not mounted.

In both cases, however, ROBAR must respond to an appropriate mount message (for initialization with MAREN only for MTCs that do not yet have a BOT label).

If the mount message is received via MAREN, a branch is made to "error case" <MAR5>. If initialization is performed using INIT, processing is resumed at "error case" <INIT> (see message_xref file, [page 269](#)).

Action operands:	VSN=vvvvvv , DEV=mmmm
------------------	-----------------------

PAUSE**Display message text on BS2000 console with operator response**

This keyword causes a message to be displayed either on the BS2000 console of the job submitter or (in the case of an archive system message) on the consoles of all connected BS2000 systems. Confirmation of message receipt by the operator is mandatory.

The `GET_HOST` and `SET_HOST` instructions allow the BS2000 system for which the command is specified to switch to a different value.

Job processing by ROBAR is not suspended.

Action operands:	Text (to be specified by the user)
------------------	------------------------------------

Example

:*:MR500:	PAUSE	? ROB5000 VOLUME (vvvvvvv) NOT IN ARCHIVE; CONTACT SYSTEM ADMINISTRATOR (TEL: ..)
-----------	-------	--

PROCESS-OFFLINE**Cancel online processing of a notification message**

You can use this instruction to cancel online processing of a notification message and add it to the client server message queue (the priority must be specified).

The instruction is ignored in batch mode.

Action operands:	PRIORITY=[L / N / H]
------------------	----------------------

RE-ENTER**Re-enter the current message in the message queue**

This statement re-enters the current message in the server message queue so that it can be restarted later (e.g. once an error is eliminated). The statement is frequently issued together with `SUSPEND-ROBOT-PROCESSING` as this prevents messages being lost.

Note that this statement can affect message sequences.

Action operands:	TSN=tttt,VSN=vvvvvv
------------------	---------------------

READ-BARCODE**Preset barcode evaluation for subsequent MO and EJ robot commands**

This statement allows you to make presettings relating to barcode reading for subsequent MO and EJ robot commands. This is done by changing the status field, which is recognizable by the `ss` in the command MO in the `roboter_cmds` file. Further details can be found in the documentation of the manufacturer [15].

The following definitions are set by default in the `robar_resp` file:

```
:*:MR051: READ-BARCODE ON
*:MR052: READ-BARCODE OFF
*:MR053: READ-BARCODE DEFAULT
```

Action operands:	ON	Barcode reading enabled; status field filled with value 1
	OFF	Barcode reading disabled; status field filled with value 0
	DEFAULT	The global robot barcode status is used; status field empty

Example

The following sequence is provided for mounting a cartridge and checking the barcode:
MR051,RC001,MR052

READ-CONFIG**Reread the configuration file and update its status**

Action operands:	none
------------------	------

RECORD**Write text to error logging file or change error counter**

Action operands:	ERRLOG=<text>	Write <text> in the ROBAR error logging file; <text> can contain the variable fields vvvvvv, tttt, mmmm etc. Message text: uppercase letters, variable fields: lowercase letters
	ERRCNT=INCREMENT, VSN=vvvvvv [,DEV=mmmm]	Increment error counter of the specified cartridge (and of the specified device)
	ERRCNT=INCREMENT, DEV=mmmm	Increment error counter of the specified device
	ERRCNT=DECREMENT, VSN=vvvvvv [,DEV=mmmm]	Reduce error counter of the specified cartridge (and of the specified device)
	ERRCNT=DECREMENT, DEV=mmmm	Reduce error counter of the specified device
	ERRCNT=RESET, VSN=vvvvvv [,DEV=mmmm]	Set error counter of the specified cartridge (and of the specified device) to "0"
	ERRCNT=RESET, DEV=mmmm	Set error counter of the specified device to "0"

Example

:*:MR180:	RECORD	ERRLOG=TOO MANY ERRORS OR UNRECOVERABLE ERROR FOR THAT DEVICE mmmm
-----------	--------	--

See also [section "Information on the error logging file"](#) on page 53.

RELEASE**Release freepool files and foreign cartridges**

RELEASE releases task-specific freepool files (see [page 86](#)) and foreign MTCs in the output units (see [page 92](#)).

Action operands:	FREEPOOL-TSN	(task-spec. ROBAR freepool)
	FOREIGN-TAPE	(Foreign cartridges)

RES_DEVSTAT**Reset user status byte**

The status byte with the number *n* set using SET_DEVSTAT is reset for the specified device. All status bytes are reset if STATUS=ALL is set.

Action operands:	DEV=mmm, STATUS= <i>n</i> (<i>n</i> = 0 ... 9, a ... z)	(Reset status byte <i>n</i>)
	DEV=mmm, STATUS=ALL	(Reset all status bytes)

RESET-DEVSTA**Reset device status byte**

The DETACH identifier for the specified device is reset in the configuration file. The device then has the status ATTACH.

Action operands:	DEV=mmm
------------------	---------

RESET-MOUNT-COUNTER**Reset counter for MTC mount operations**

The counter that counts the MTC mount operations on this device is set to 0. This instruction must be executed after a cleaning process if the archive numbers of the cleaning cartridge do not start with *CL.

Action operands:	DEV=mmm
------------------	---------

RESPONSE**Respond to BS2000 message**

Response to a BS2000 message.

If you want to define a new response to a BS2000 message, you must ensure that the waiting program actually expects this response.

The system branches to <NOHO> if an error occurs.

Action operands:	Text (to be specified by the user)
------------------	------------------------------------

Example

:*:MR333:	RESPONSE	tttt.X
-----------	----------	--------

If the action `RESPONSE tttt.vvvvvv` follows the action `ROBAR-FPOOL (MR025)`, for example, `tttt` is replaced with the current TSN of the DMS message and `vvvvvv` with the VSN taken from the ROBAR freepool.

RESUME-ROBOT-PROCESSING**Switch the robot that is currently inactive to “ON” mode logically**

If, after receiving a notification message, this instruction is executed by the notification handler without a special robot arm being accessed (`Rob` parameter, see the documentation of the manufacturer [15]) in the actual notification (e.g. N1298, N1335, N1336), all configured robot arms are switched on logically. Otherwise only the accessed robot arm is switched on logically.

Action operands:	none
------------------	------

ROBAR-FPOOL**Remove next free cartridge from the freepool**

This keyword is used to remove the next free VSN from the freepool.

Action operands:	none
------------------	------

ROBAR-MESS**Define type of ROBAR error messages**

This keyword determines whether archive system or ROBAR messages are sent to the BS2000 system as TYPE or PAUSE messages.

Action operands:	TYPE
	PAUSE

ROUTINGCODE**Routing code of the SEND-MESSAGE command (TYPE/PAUSE)**

This keyword is used to inform the ROBAR system of the routing code specified for the parameter TypeRoutingcodes in the file SYSPAR.ROBAR-CL.<ver>.PROZPARAM.

Action operands:	<x (x = routing code, to be specified by the user)
------------------	--

SET-DEVSTAT**Set device status byte**

The DETACH identifier is entered in the configuration file for the specified file. This identifier should be set only if a DETACH, FORCE=YES is to be subsequently issued for a device by ROBAR as a result of the return code of CHK-DEVSTAT.

Action operands:	STATUS=DETACH, FORCE=YES, DEV=mmm
------------------	-----------------------------------

SET_DEVSTAT**Set user status byte**

Up to 36 different bytes can be set for the specified device during an action. These bytes should be managed by the user. They can be used, for example, to intercept infinite loops between ROBAR, NDM and DER.

Action operands:	DEV=mmm, STATUS=n (n = 0 ... 9, a ... z)
------------------	--

SET-FIELD**Define the value of an RRF variable for BS2000 or archive system command**

A constant value 'vvv..vv' with a maximum of 19 characters is assigned to the internal variable field V[f]. Each time this variable field is accessed, caused either by subsequent statements (MRxxx) or by robot commands (RCxxx), this value is used.

V[f] is a variable field in a message received by a client server (f can be one of the following characters: #, T, M, V, S, A, B, R, F, Z, U, L, H, I, E).

Action operands:	V[f]='vvv..vv'
------------------	----------------

Example

```
SET-FIELD V[S]='MB'
```

SET_HOST**Modify the target location of subsequent TYPE, PAUSE or COMMAND commands**

This instruction permits you to modify the target location of subsequent commands (TYPE, PAUSE, COMMAND).

Action operands:	*CONFIG_DEFAULT	The value of the notification_host parameter defined in the configuration file defines the target location (either *ALL or a specific server).
	*ALL	The target location is all servers defined in the configuration file.
	*NONE	No server will forward a subsequent TYPE, PAUSE or COMMAND.
	*UNCHANGED	The current valid setting remains unchanged
	text_1..6	Defines a specific server as the target location.

SINIX-SYSTEM**Execute system command**

The keyword `SINIX-SYSTEM` is used to issue a system command on the ROBAR server.

System commands are normally entered in lowercase letters. However, in ROBAR rule files lowercase letters are reserved for variables that must be supplied with their appropriate values. It is therefore necessary to enter system commands in uppercase letters or store them in a procedure whose name is in uppercase letters. The procedure name can then be used as an action operand.

Action operands:	<system command> (to be specified by the user)
------------------	---

Example

The system command `echo` is to display the current VSN on the console.

This command must be written as a shell procedure so that it can be executed. An entry in the `message_resp` file could look like this:

:*:MR050:	SINIX_SYSTEM	ECHO vvvvvv
-----------	--------------	-------------

The `ECHO` procedure under `$HOME` could have the following contents:

```
echo "VSN = $1 " > /dev/console
```

When the action `MR050` is executed, the console displays:

```
VSN = <current_VSN>
```

If further information of the system message passed to the ROBAR server is to be displayed (after the TSN), the `ECHO` procedure can be extended:

```
echo "VSN = $1 Console message = $2" > /dev/console
```

When the action `MR050` is executed, the console displays:

```
VSN = <current_VSN> Console message = <TSN> <msg_no> ....
```

SKIP-IF-EMPTY**Branch to <DVMT> if device empty**

This keyword is used to branch to the `<DVMT>` exit if the device `mmmm` is empty.

Action operands:	DEV=mmmm
------------------	----------

SKIP-IF-OCCUPIED**Branch to <DVOC> if device occupied**

This keyword is used to branch to <DVOC> exit if the device mmmm is occupied.

Action operands:	DEV=mmmm
------------------	----------

SUSPEND-ROBOT-PROCESSING**Switch robot arm to “OFF” mode logically**

If, after receiving a notification message, this instruction is executed by the notification handler without a special robot arm being accessed (parameter Rob, see the documentation of the manufacturer [15]) in the actual notification (e.g. N0930), all configured robot arms are switched off logically. Otherwise only the accessed robot arm is switched off logically.

Action operands:	none
------------------	------

SWITCH-CONNECTION**Use an alternative address as the connection address at the next start of ROBAR-SV**

If two connection addresses are defined in the configuration file, issuing this instruction has the effect of using the previous alternative address as the connection address for the next start.

If only one connection address is specified, it is also used in the next start. SWITCH is output as the ROBAR status in the DISPLAY and MANUAL menu.

Action operands:	none
------------------	------

TEST-FIELD**Compare internal variable field with the defined value**

This statement compares the internal variable field V[f] or A[f] with the constant value 'vvv..vv' (maximum 19 characters). If the values are identical, a branch to the destination <LABL> is performed, if the values are not identical, the file sequence of the message_xref file is continued.

V[f] stands for the variable field in a message received from the client server, A[f] stands for the variable field in a response received from the archive system. f can be one of the following characters: #, T, M, V, S, A, B, R, F, Z, U, L, H, I, E. <labl> is a freely selectable branch destination in the algorithm of the current message_xref-file.

Action operands:	V[f]='vvv..vv',SKIP=<labl>
	A[f]='vvv..vv',SKIP=<labl>

Example

```
TEST-FIELD V[Z]='-----',SKIP=<CDAS>
```

TYPE**Display message text on BS2000 console**

This keyword causes a message to be displayed either on the BS2000 console of the job submitter or (in the case of an archive system message) on the consoles of all connected BS2000 systems.

The GET_HOST and SET_HOST instructions allow the server for which the command is specified to switch to a different value.

Action operands:	<text> (to be specified by the user)
------------------	--------------------------------------

Example

:*:MR410:	TYPE	% ROB4004 TAPE CARTRIDGE DEVICE UNLOADED (DEV=mmmm / VSN = vvvvvv)
-----------	------	---

UPD_VOLMGR**Transfer information relating to data media to MAREN system**

This instruction informs the tape management program MAREN running on the BS2000 system that the data medium defined using `VOLIN` is henceforth available via the storage location defined using `LOC`. `VOLOUT` is used to define that the relevant data medium is no longer available in the storage location.

Action operands:	<code>VOLIN=vvvvvv,LOC=11111111</code>
	<code>VOLOUT=vvvvvv,LOC=11111111</code>

UPDCONF**Record device allocation to BS2000 hosts**

UPDCONF causes an entry defining the allocation of devices to the BS2000 systems to be made in the ROBAR-SV configuration file. This action should be specified for the BS2000 messages NKR0110, NKR0045 and NKR0048.

If no target server can be defined, the system branches to the error exit <DVDT>.

Action operands:	<code>ATTACH-DEV mmmm</code>
	<code>DETACH-DEV mmmm</code>

WAIT**Wait time in seconds**

`n` seconds are waited.

Action operands:	Wait time <code>n</code> in seconds (to be specified by the user)
------------------	---

Example

<code>::MR205:</code>	WAIT	10
-----------------------	------	----

Extract from the file message_resp

```

/*****
/*
/* CUSTOMER OPTIONS :
/*****
/*
/*****
/* MRV01 : wait time before KEEP can be activated
/* STANDARD=0
/* OPTION=20 (seconds)
/*****
*:MRV01: WAIT 0
*:MRV01: WAIT 20
/*****
/* MRV02 : response for a wrong tape volume by MAREN-INIT
/* STANDARD=<tsn>.N wrong VSN is rejected
/* OPTION=<tsn>. overwrite tapes with a new VSN (different from
/* the mounted one)
/*****
*:MRV02: RESPONSE tttt.N
*:MRV02: RESPONSE tttt.
/*****
/* MRV10 : response for a NKVT013 'WRONG_VOLUME' treatment (*UNKNOWN)
/* SET_DEVSTAT DEV=mmm,STATUS=6 -> <tsn>. (STANDARD)
/* RES_DEVSTAT DEV=mmm,STATUS=6 -> <tsn>.N (OPTION)
/* Note: if the tttt.N case is activated, the MRV14 is also called
/*****
*:MRV10: RES_DEVSTAT DEV=mmm,STATUS=6
*:MRV10: SET_DEVSTAT DEV=mmm,STATUS=6
/*****
/* MRV11 : response for a NKVT013 'WRONG_VOLUME' treatment (WRONG VSN)
/* STANDARD=<tsn>.N Wrong VSN is rejected
/* (with SET_DEVSTAT DEV=mmm,STATUS=M)
/* OPTION=<tsn>.
/* Note: if the tttt.N case is activated, the MRV15 is also called
/*****
*:MRV11: SET_DEVSTAT DEV=mmm,STATUS=M
*:MRV11: RESPONSE tttt.
/*****
/* MRV12 : action for 'UNLOADED TAPE' treatment when the tape cannot be
/* removed from the device
/* STANDARD=<tsn>.N Job is cancelled
/* OPTION=WAIT 0 Job is pended
/*****
*:MRV12: RESPONSE tttt.N
*:MRV12: WAIT 0
/*****

```

```

/* MRV13 : action for 'TAPE LENGTH VIOLATION' - volume cannot be used      *
/*          STANDARD=SET_DEVSTAT Put volume in I/O-box                      *
/*          OPTION=WAIT 0          Put volume back at storage position      *
/*****
*:MRV13: SET_DEVSTAT DEV=mmm,STATUS=A
*:MRV13: WAIT          0
/*****
/* MRV14 : action on volume after a wrong volume (*UNKOWN) is rejected      *
/*                                               (MRV10)*
/*          STANDARD=WAIT 0          Put volume back at storage position      *
/*          OPTION =SET_DEVSTAT Put volume in I/O-box                      *
/*****
*:MRV14: WAIT          0
*:MRV14: SET_DEVSTAT DEV=mmm,STATUS=7
/*****
/* MRV15 : action on volume after a wrong volume (WRONG VSN) is            *
/*          rejected (MRV11)
/*          STANDARD=WAIT 0          Put volume back at storage position      *
/*          OPTION =SET_DEVSTAT Put volume in I/O-box                      *
/*****
*:MRV15: WAIT          0
*:MRV15: SET_DEVSTAT DEV=mmm,STATUS=7
/*****
/* Negative response to MARM1IB message when device is detached:          *
/* -----
/* tttt.A : abort all the requests (default)
/* tttt.N : cancel the current request
/* WAIT 0 : do nothing
/*****
*:MRV17: RESPONSE      tttt.A
*:MRV17: WAIT          0
*:MRV17: RESPONSE      tttt.N
/*****
/* MRV20 : action for DMSODF7 message, if a volume with std tape label is  *
/*          overwritten with a non-std tape label
/*          STANDARD=WAIT 0 Job is pended
/*          OPTION=<tsn>.0 Job error (overwrite rejected)
/*          OPTION=<tsn>. Warning message is accepted - go further
/*****
*:MRV20: WAIT          0
*:MRV20: RESPONSE      tttt.0
*:MRV20: RESPONSE      tttt.
/*****
/* Action after successful recovery of a EXC0858 LOAD/UNLOAD CHECK          *
/* -----
/* /CHA-TAPE UNIT=mmm,ACT=MOVE : Usage of another device
/* /CHA-TAPE UNIT=mmm,ACT=CANCEL : cancel the current request
/*****

```



```

:*:MRV21:  COMMAND          /CHA-TAPE UNIT=mmmm,ACT=MOVE
/*:MRV21:  COMMAND          /CHA-TAPE UNIT=mmmm,ACT=CANCEL
/*****
/* MRV22: response to the job when the tape cannot be removed from the device*
/* -----*
/* WAIT 0                                : do nothing*
/* /CHA-TAPE UNIT=mmmm,ACT=CANCEL : cancel the current request*
/*****
:*:MRV22:  WAIT            0
/*:MRV22:  COMMAND          /CHA-TAPE UNIT=mmmm,ACT=CANCEL
/*****
/* MRV23: action on a device when the tape cannot be removed from device*
/* -----*
/* SET_DEVSTAT DEV=mmmm,STATUS=I : do nothing (default)*
/* /DET mmmm,FORCE=YES           : the device is detached*
/*****
:*:MRV23:  SET_DEVSTAT    DEV=mmmm,STATUS=I
/*:MRV23:  COMMAND          /DET mmmm,FORCE=YES
/*****
/* MRV24: action on a device when too many errors occurred for the device*
/* -----*
/* /DET mmmm,FORCE=YES           : the device is detached (default action)*
/* SET_DEVSTAT DEV=mmmm,STATUS=I : ignore all future actions for the device*
/*                               When the device is repaired, a command*
/*                               /DET FORCE=YES must be manually issued and,*
/*                               then the device can be attached for normal*
/*                               usage*
/*****
:*:MRV24:  COMMAND          /DET mmmm,FORCE=YES
/*:MRV24:  SET_DEVSTAT    DEV=mmmm,STATUS=I
/*****
/* MRV25: action on a volume when too many errors occurred for the volume*
/* -----*
/* SET_DEVSTAT DEV=mmmm,STATUS=2 : the volume is ejected and the message*
/*                               ROB7060 is issued (default)*
/* RES_DEVSTAT DEV=mmmm,STATUS=2 : the volume is kept in the robot*
/*****
:*:MRV25:  SET_DEVSTAT    DEV=mmmm,STATUS=2
/*:MRV25:  RES_DEVSTAT    DEV=mmmm,STATUS=2
/*****
/* MRV26: action on the job when too many errors occurred for the device*
/* -----*
/* /CHA-TAPE UNIT=mmmm,ACT=MOVE : job is moved to another device (default)*
/* /CHA-TAPE UNIT=mmmm,ACT=CANCEL : the job is cancelled*
/* WAIT 0                                : nothing special is done*
/* Note: The MRV26 is not available for direct MAREN mount request*
/*****
:*:MRV26:  COMMAND          /CHA-TAPE UNIT=mmmm,ACT=MOVE

```

```

/*:MRV26:  COMMAND      /CHA-TAPE UNIT=mmmm,ACT=CANCEL
/*:MRV26:  WAIT         0
/*****
/* MRV27: action on the job when too many errors occurred for the volume      *
/* -----
/* /CHA-TAPE UNIT=mmmm,ACT=CANCEL : the job is cancelled (default)           *
/* WAIT 0                          : nothing special is done                   *
/* Note: The MRV27 is not available for direct MAREN mount request           *
/*****
*:MRV27:  COMMAND      /CHA-TAPE UNIT=mmmm,ACT=CANCEL
*:MRV27:  WAIT         0
/*****
*
/* MRV28: action on error counter when a device is attached                    *
/* -----
/* RECORD  ERRCNT=RESET,DEV=mmmm : reset the device error counter (default)*
/* WAIT 0                          : the device error counter remains unchanged*
/*****
*:MRV28:  RECORD      ERRCNT=RESET,DEV=mmmm
*:MRV28:  WAIT         0
/*****
*
/* MRV29: action on error counter when a volume is inserted                    *
/* -----
/* RECORD  ERRCNT=RESET,VSN=vvvvvv : reset the error counter (default)      *
/* WAIT 0                          : the error counter remains unchanged    *
/*****
*:MRV29:  RECORD      ERRCNT=RESET,VSN=vvvvvv
*:MRV29:  WAIT         0
/*****
/* Option for automatic Eject continuation after an HICAP door is closed      *
/* -----
/* The MRV30 option allows to have an automatic continuation of the EJECT    *
/* operation after a HICAP door has been opened and closed.                   *
/* -----
/* Possible values:
/* -----
/* WAIT 0 : No automatic continuation is done. When the message ROB0035 is   *
/* issued. When the I/O-BOX is empty, the operator must still issue*
/* the command: /SEND-MESSAGE TO=OPERATOR,MESSAGE='<T I/O-BOX EMPTY' *
/* -----
/* EJECT-CONT : When an HICAP door is closed, ROBAR automatically restarts  *
/* the ejection.
/*****
*:MRV30:  WAIT         0
*:MRV30:  EJECT-CONT
/*****
/* MRV31: action of ROBAR-CL-SDF in case of //EXPORT-ROBAR-VOLUME            *

```

```

/* ----- *
/* Default: tttt. : MAREN is present and catalogue must be updated *
/* Option: tttt.1 : Either MAREN is not present or the catalogue is not to *
/* be updated *
/******
*:MRV31: RESPONSE tttt.
*:MRV31: RESPONSE tttt.1
/******
/* Setting of BARCODE reader for a normal MOUNT (READ-BARCODE options) *
/* ----- *
/* This option is relevant with AMU version 3.0 or higher. For previous *
/* AMU versions, please use the RCV01 option in the roboter_cmds file. *
/* *
/* ON: the BARCODE reader is set to ON for all MOUNT's *
/* OFF: the BARCODE reader is set to OFF for normal MOUNT's *
/* DEFAULT: the current setting of the BARCODE reader in the AMU is used *
/* for the normal MOUNT's. *
/* *
/* Remark: *
/* ----- *
/* The BARCODE is always set to ON for the special MOUNT (INIT, MARM1IB,...)*
/******
*:MRV54: READ-BARCODE DEFAULT
*:MRV54: READ-BARCODE ON
*:MRV54: READ-BARCODE OFF
/******
/* MRV60: response to message DMS0DB (SPECIFIED FILE SEQUENCE NUMBER NOT *
/* FOUND ON TAPE) *
/* - WAIT 0 : no action *
/* - tttt.0 : skip file *
/* - tttt.1 : retry *
/******
*:MRV60: WAIT 0
*:MRV60: RESPONSE tttt.0
*:MRV60: RESPONSE tttt.1
/******
/* MRV61: response to message ARC0901 (READ ERROR ON VSN) *
/* - WAIT 0 : no action *
/* - tttt.0 : skip file *
/* - tttt.1 : skip block *
/******
*:MRV61: WAIT 0
*:MRV61: RESPONSE tttt.0
*:MRV61: RESPONSE tttt.1
/******
/* MRV62: response to message ARC0902 (FORMAT OR BLOCK NUMBER ERROR ON VSN) *
/* - WAIT 0 : no action *
/* - tttt.0 : skip file *

```

```

/* - tttt.1 : skip block
/*****
*:MRV62: WAIT 0
/*:MRV62: RESPONSE tttt.0
/*:MRV62: RESPONSE tttt.1
/*****
/* MRV63: response to message ARC0903 (OPEN ERROR ON VSN)
/* - WAIT 0 : no action
/* - tttt.0 : skip file
/* - tttt.1 : skip block
/*****
*:MRV63: WAIT 0
/*:MRV63: RESPONSE tttt.0
/*:MRV63: RESPONSE tttt.1
/*****
/* MRV66: response to message ARC0906 (WRONG BLOCK FOUND ON VSN)
/* - WAIT 0 : no action
/* - tttt.0 : abandon volume
/* - tttt.1 : continue processing
/*****
*:MRV66: WAIT 0
/*:MRV66: RESPONSE tttt.0
/*:MRV66: RESPONSE tttt.1
/*****
/* MRV67: response to message ARC0907 (DMS ERROR DURING MOUNT OF VSN FOR
/* ARCHIVE)
/* - WAIT 0 : no action
/* - tttt.T : terminate ARCHIVE with error
/* - tttt.C : continue ARCHIVE with another VSN
/*****
*:MRV67: WAIT 0
/*:MRV67: RESPONSE tttt.T
/*:MRV67: RESPONSE tttt.C
/*****
/* MRV68: response to message ARC0908 (DMS ERROR DURING MOUNT OF VSN FOR
/* ARCHIVE)
/* - WAIT 0 : no action
/* - tttt.T : terminate ARCHIVE with error
/* - tttt.C : continue ARCHIVE with another VSN
/* - tttt.R : retry
/*****
*:MRV68: WAIT 0
/*:MRV68: RESPONSE tttt.T
/*:MRV68: RESPONSE tttt.C
/*:MRV68: RESPONSE tttt.R
/*****
/* device type specific wait times are in the form MRVxi with
/* MRVx1 for 3588

```

```

/*      MRVx2 for 3590                                          *
/*      MRVx3 for 3591/LTO-Ux                                  *
/*      MRVx4 for CentricStor                                  *
/*
/*      MRVxE extends wait times for extended media          *
/*****
/*****
/* MRVAi (previously MRV04)                                    *
/* different keep after cleaning time for the different device types *
/* 3588: cleaning time is 25 sec    -> wait time is 20 sec  MRVA1  *
/* 3590: cleaning time is 42 sec    -> wait time is 35 sec  MRVA2  *
/* 3591: cleaning time is 145 sec   -> wait time is 140 sec MRVA3  *
/* CentricStor: no cleaning by ROBAR -> wait time is 0 sec  MRVA4  *
/*****
*:MRVA1:  WAIT          20
*:MRVA2:  WAIT          35
*:MRVA3:  WAIT         140
*:MRVA4:  WAIT          0
*:MRVAE:  WAIT          0
/*****
/* wait times before response tttt.mmmm or tttt. or ...      *
/*  MRVBi:  for MARM1IB message                               *
/*  MRVCi:  for USAGE = SPECIAL (INIT, LIST, FDDRL,...)     *
/*  MRVDi:  for NKVT014 message                               *
/*****
*:MRVB1:  WAIT          10
*:MRVB2:  WAIT          10
*:MRVB3:  WAIT          10
*:MRVB4:  WAIT          10
*:MRVBE:  WAIT          0
*:MRVC1:  WAIT          40
*:MRVC2:  WAIT          40
*:MRVC3:  WAIT          45
*:MRVC4:  WAIT          10
*:MRVCE:  WAIT          36
*:MRVD1:  WAIT          40
*:MRVD2:  WAIT          40
*:MRVD3:  WAIT          45
*:MRVD4:  WAIT          10
*:MRVDE:  WAIT          36
/*****
/* Wait time for EMERGENCY UNLOAD                             *
/* -----                                                    *
/*
/*  MRVii:  wait before making the ULU                        *
/*
/*  MRVEi:  when tape is at LOT (Label of Tape)              *
/*  MRVFi:  first keep trial, near to BOT (Beginning Of Tape) *

```

```

/* MRVGi: second keep trial, means fullness of the tape (Middle Of Tape) *
/* MRVHi: last keep trial, near to EOT (End Of Tape) *
/* (only for slow devices) *
/* *
/* with i = 1 for 3588 *
/* 2 for 3590 *
/* 3 for 3591 *
/* 4 for CentricStor *
/* *
/* E to extend wait times for extended media *
/* *
/* These values can be modified to optimize the wait times of ROBAR *
/* according to the mean level of fullness of the tapes. *
/* *
/* The sum of the MRVFi, MRVGi and MRVHi corresponds to the maximal UNLOAD *
/* time of the device in case of EMERGENCY UNLOAD *
/* *
/* If the sum is reduced under the maximal unload time of the device, *
/* the UNLOAD is no more guaranteed in all cases, but ROBAR will not *
/* remain busy for a long time. *
/* *****
:*:MRVE1: WAIT 0
:*:MRVE2: WAIT 0
:*:MRVE3: WAIT 0
:*:MRVE4: WAIT 0
:*:MRVEE: WAIT 0
:*:MRVF1: WAIT 70
:*:MRVF2: WAIT 180
:*:MRVF3: WAIT 180
:*:MRVF4: WAIT 0
:*:MRVFE: WAIT 0
:*:MRVG1: WAIT 140
:*:MRVG2: WAIT 60
:*:MRVG3: WAIT 60
:*:MRVG4: WAIT 0
:*:MRVGE: WAIT 0
:*:MRVH1: WAIT 0
:*:MRVH2: WAIT 0
:*:MRVH3: WAIT 0
:*:MRVH4: WAIT 0
:*:MRVHE: WAIT 0
:*:MRVI1: WAIT 10
:*:MRVI2: WAIT 10
:*:MRVI3: WAIT 10
:*:MRVI4: WAIT 0
:*:MRVIE: WAIT 0
/* *****
/* wait time before keep *

```

```

/* MRVJi : after a normal UNLOAD when <N202> /UNLOAD - old MRV15          *
/*****
:*:MRVJ1:  WAIT           25
:*:MRVJ2:  WAIT           25
:*:MRVJ3:  WAIT           40
:*:MRVJ4:  WAIT           0
:*:MRVJE:  WAIT           0
/*****
/* END OF THE CUSTOMER OPTIONS                                           *
/*****
. . .

:*:MR960:  TYPE           %  ROB9600 ROBAR COUNTS A GRAVE ERROR ON DEVICE mmmm
:*:MR961:  TYPE           %  ROB9601 ROBAR DEDUCTS A GRAVE ERROR FOR DEVICE
mmmm
:*:MR962:  TYPE           %  ROB9602 ROBAR COUNTS A GRAVE ERROR ON VOLUME
vvvvvv
:*:MR963:  TYPE           %  ROB9603 ROBAR DEDUCTS A GRAVE ERROR FOR VOLUME
vvvvvv
:*:MR980:  TYPE           %  ROB9800 CENTRICSTOR IS UNABLE TO EXECUTE COMMAND
:*:MR981:  TYPE           %  ROB9801 COMMAND IS NOT PERMITTED
/*-----
:*:MR983:  TYPE           %  ROB9803 COMMAND NOT PERMITTED: FOREIGN VOLUMES AND
FREEPOOLS NOT SUPPORTED
/*-----
:*:MRSAT:  TYPE           %  ROBOSAT FROM ROBAR VIEW TAPE CARTRIDGE mmmm DEVICE
IS ATTACHED
:*:MRSKE:  TYPE           %  ROBOSKE REMOVING TAPE CARTRIDGE FROM DEVICE mmmm
:*:MRSER:  PAUSE          ?  ROBOSER INCONSISTENCY IN AML DATABASE FOR DEVICE
mmmm

```

7.2.6 File roboter_cmds

The specific `roboter_cmds` file is shipped with ROBAR and should not be changed. It contains the archive system commands as required by the archive system.

Structure of the entries

Each entry begins in column 1 of the line and has the format:

```
:*:RC###:H '<cmd>' F
```

Example

```
:*:RC004:H '<####,MO , ,FFFF,1,r,0mm,CLEAN,SS,AAAAAAA,BBBBBBBB,
UUUUUUUUU>' F.
```

where

- ### 3-digit number of the action code
This action code must be **unique** within the file.
- H Identifier as to whether the command should be listed in the menu bar of the
MANUAL parameter.
- cmd Archive system command (see the documentation of the manufacturer [15])
- F Identifier for device allocation (column 78)
F = fixed device allocation

To indicate fixed device allocation (MTCs are mounted only on devices proposed by BS2000 device management) column 78 of the archive system commands `MO` and `MO, , ,CLEAN` contains the identifier `F`.

Extract from the file roboter_cmds for the SCSI interface

```

/*
/* WARNING: DO NOT MODIFY, DELETE OR EVEN MOVE THE NEXT LINE (RC000)
*:RC000:  '<####,CCCC, ,FFFF,1,R,OMM,VVVVVV,SS,AAAAAAAA,BBBBBBBB,UUUUUUUU>'
/*
*:RC001:H  '<####,MO  ,
,FFFF,1,r,0mm,vvvvvv,ss,AAAAAAAA,BBBBBBBB,UUUUUUUU>' F
*:RC003:H  '<####,KE  , ,FFFF,1,r,0mm,VVVVVV, ,AAAAAAAA,BBBBBBBB,UUUUUUUU>'
*:RC004:  '<####,MO  , ,FFFF,1,r,0mm,CLEAN
,SS,AAAAAAAA,BBBBBBBB,UUUUUUUU>' F
*:RC005:H  '<####,EJ  , ,FFFF,1,r,eee,vvvvvv,ss,AAAAAAAA,BBBBBBBB,UUUUUUUU>'
*:RC006:H  '<####,IN  , ,FFFF,1,r,iii,VVVVVV, ,AAAAAAAA,BBBBBBBB,UUUUUUUU>'
*:RC007:H  '<####,ULV , ,FFFF,1, , ,vvvvvv,SS,AAAAAAAA, ,UUUUUUUU>'
*:RC008:H  '<####,ULK , ,FFFF,1, , ,VVVVVV,SS,aaaaaaa, ,UUUUUUUU>'
*:RC014:  '<####,ACOM, ,FFFF,1, , ,VVVVVV, ,AAAAAAAA,BBBBBBBB,UUUUUUUU>'
*:RC015:  '<####,ROSA, ,FFFF,1,z, , , , , ,UUUUUUUU>'
*:RC016:  '<####,ROSO, ,FFFF,1,r, , , , , ,UUUUUUUU>'
*:RC018:  '<####,MAN , ,FFFF,1,r,hhh, , , , ,UUUUUUUU>'
*:RC019:  '<####,AUTO, ,FFFF,1,r, , , , , ,UUUUUUUU>'
*:RC022:  '<####,KE  , ,FFFF,1,r,0mm,CLEAN , ,AAAAAAAA,BBBBBBBB,UUUUUUUU>'
*:RC026:  '<####,ULU , ,FFFF,1,r,0mm, , , , , ,UUUUUUUU>'
*:RC028:H  '<####,EJT , ,FFFF,1,r,eee,vvvvvv,ss,AAAAAAAA,BBBBBBBB,UUUUUUUU>'
*:RC029:  '<####,INSC, ,FFFF,1,r,iii, , , , ,bbbbbbb,UUUUUUUU>'
*:RC030:  '<####,EJTC, ,FFFF,1,r,eee, , , , ,bbbbbbb,UUUUUUUU>'
*:RC031:  '<####,ULK , ,FFFF,1, , ,VVVVVV,SS,0000mm01, ,UUUUUUUU>'
*:RC045:  '<####,EJCL, ,FFFF,1,r,0mm, , , , , ,UUUUUUUU>'
/*
/* From here, the numbering cannot be modified.
/* RC052 and RC054 cannot be activated for MANUAL menu (with H).
/* RC050, RC052, RC053 and RC054 are not permitted action in message_xref.
/*
*:RC050:H  '<####,EJP , , ,1,r,eee,VSN=aaaaaa-bbbbb>'
*:RC051:H  '/UNLOAD mm,SYSTEM=aaaaaa'
*:RC052:  '<####,ROBS, ,ffff,1,r, , , ,ss, , ,uuuuuuuu>'
*:RC053:  '<####,EJTP, , ,1,r,eee,VSN=aaaaaa-bbbbb>'
*:RC054:  '<####,NTFY, ,ffff,1,r, , ,vvvvvv,ss, , ,uuuuuuuu>'

```

Extract from the file roboter_cmds for ETERNUS CS (ABBA interface)

```

/*
/* WARNING: DO NOT MODIFY, DELETE OR EVEN MOVE THE NEXT LINE (RC000)
*:RC000:  '<####,CCCC, ,FFFF,1,R,0mm,VVVVVV,SS,AAAAAAAA,BBBBBBBB,UUUUUUUU>'
/*
*:RC001:H '<####,MO , ,FFFF,1,r,0mm,vvvvvv,
,AAAAAAAA,BBBBBBBB,UUUUUUUU>' F
*:RC003:H '<####,KE , ,FFFF,1,r,0mm,VVVVVV, ,AAAAAAAA,BBBBBBBB,UUUUUUUU>'
*:RC005:H '<####,EJ , ,FFFF,1,r,eee,vvvvvv,ss,AAAAAAAA,BBBBBBBB,UUUUUUUU>'
*:RC007:H '<####,ULV , ,FFFF,1, , ,vvvvvv,SS,AAAAAAAA, ,UUUUUUUU>'
*:RC008:H '<####,ULK , ,FFFF,1, , ,VVVVVV,SS,aaaaaaa, ,UUUUUUUU>'
*:RC014:  '<####,ACOM, ,FFFF,1, , ,VVVVVV, ,AAAAAAAA,BBBBBBBB,UUUUUUUU>'
*:RC015:  '<####,ROSA, ,FFFF,1,z, , , , , ,UUUUUUUU>'
*:RC019:  '<####,AUTO, ,FFFF,1,r, , , , , ,UUUUUUUU>'
*:RC026:  '<####,ULU , ,FFFF,1,r,0mm, , , , , ,UUUUUUUU>'
*:RC028:H '<####,EJT , ,FFFF,1,r,eee,vvvvvv,ss,AAAAAAAA,BBBBBBBB,UUUUUUUU>'
*:RC031:  '<####,ULK , ,FFFF,1, , , ,VVVVVV,SS,0000mm01, ,UUUUUUUU>'
*:RC038:  '<####,ULK , ,FFFF,1, , , , ,SS,bbbbbbbb, ,UUUUUUUU>'
*:RC040:H '<####,CVA , ,FFFF,1, , , ,vvvvvv, , , , >'
*:RC041:H '<####,MO , ,FFFF,1,r,0mm,vvvvvv,S
,AAAAAAAA,BBBBBBBB,UUUUUUUU>' F
*:RC042:  '<####,PR , ,FFFF,1,r, , ,vvvvvv,S , , ,UUUUUUUU>'
/*
/* From here, the numbering cannot be modified.
/* RC052 and RC054 cannot be activated for MANUAL menu (with H).
/* RC052 and RC054 are not permitted action in message_xref.
/*
*:RC051:H '/UNLOAD mm,SYSTEM=aaaaaa'
*:RC052:  '<####,ROBS, ,ffff,1,r, , , ,ss, , ,uuuuuuuu>'
*:RC054:  '<####,NTFY, ,ffff,1,r, , ,vvvvvv,ss, , ,uuuuuuuu>'

```

7.2.7 File error_defines

The `error_defines` file contains the actions to be executed in the event of serious errors (e.g. robot failure):

```
N002: STOP
N003: EXIT
N004: EXIT
NRDY: STOP
TIME: STOP, REPEAT=YES
```

The archive system error code (for archive systems that are not ready for operation (NRDY)), the appropriate action and the action operands should be specified for each error. The action operands are optional. Keywords must be used for the individual actions. The identifier A can be placed in front of each keyword (but only if there is an automatic operator connected to the ROBAR server). The following entries are permitted as keywords:

Keyword	Meaning
ATOP	Output to the automatic operator
[A]EXIT	Program termination [with output to the automatic operator]
[A]STOP	Stop archive system [with output to the automatic operator]

Neither `STOP` nor `EXIT` should be used if possible, instead an appropriate action should be included in the `message_xref` file (e.g. notify all BS2000 consoles by means of a message and then issue the `SUSPEND-ROBOT-PROCESSING` command. Once the reason for the interruption has been removed, the `RESUME-ROBOT-PROCESSING` command will be issued by means of an archive system notification).

ATOP

Output to the automatic operator

This keyword causes the archive system error code to be passed to the automatic operator. The appropriate actions (such as output to loudspeaker, or telephone dialing) for these error codes should be entered in the automatic operator menu. This keyword may be specified only if there is an automatic operator connected to the ROBAR server.

Example

```
N001: ATOP
```

EXIT**Program termination**

EXIT terminates the ROBAR system if the corresponding error occurs.

Example

```
N002: EXIT
N003: AEXIT
```

STOP**Stop archive system**

The effect of this keyword is to stop any further jobs being sent to the archive system in which the error occurred.

Action operands:	REPEAT=YES
------------------	------------

The action operand REPEAT=YES causes the current job (which ROBAR already considers as deleted) to be given preference when the robot status changes to ON.

If the archive system sends an error message to ROBAR as a result of an action, the message is first displayed on the console of the appropriate BS2000 system. A check is then made as to whether it is an error message defined in `error_defines`. If so, the actions defined there for the message are executed and processing of the BS2000 job is terminated.

If the error is not defined in `error_defines`, the appropriate processing step in `message_xref` is performed.

Example

The `error_defines` file contains the following archive system error codes:

```
NRDY:  ASTOP
N002:  ASTOP
N003:  AEXIT
```

In response to the BS2000 message

```
NKVT011 TAPE 'vvvvvv' DISMOUNTED FROM DEVICE 'mmmm'
```

the following ROBAR actions in the action list are to be executed:

```
:*:MF005: RC003,MR404,RC004,RC022,MR418;\
. . .
MR668
```

If a negative acknowledgment with error code N002 is received from the archive system in response to the action RC003, the following actions are executed:

1. The archive system return message and information on the error code are sent to the BS2000 system.
2. The archive system error code is sent to the automatic operator.
3. No further jobs are allocated to the defective robot.
4. The current job is not completed by ROBAR, i.e. the actions MR404, RC004, RC022 and MR418 are not executed.

Structure of the entries

Comment lines always begin with /*.

Each entry begins in column 1 of the line and has the format:

eno: keywd

where

eno 4-character archive system error code, NRDY or TIME.
This error code must be unique within the file.

keywd Keyword + action operand.

7.3 ROBAR rule files for ETERNUS CS

Operating ETERNUS CS requires special ROBAR rule files which differ from the usual ROBAR rule files in the following points:

- No rewind time. ETERNUS CS allows a virtual volume to be unmounted directly after the operator has issued an UNLOAD. This also applies to “manual” unload procedures (ULU statement) performed by the operator when an accessing problem occurs (i.e. KE generally immediately after ULU).
- Reduced waiting time while checking the MTC header (tape label) during mounting.
- Device cleaning for real tape drives is controlled by ETERNUS CS, so device cleaning no longer features in the ROBAR rule file.
- Volume import or export of MTCs are not possible.
- Foreign volumes are unknown.
- “Fast mount” support (see [page 68](#)) via CVA statement.

ROBAR only acknowledges MOUNT statements for initializations. In this case a “fast mount” request is issued to ETERNUS CS and the waiting time for the acknowledgment to be received is adjusted to the short reaction times of ETERNUS CS.

7.4 Modifications in the ROBAR rule files

If the standard files do not cover all the requirements of your data center, you can modify them before the relevant ROBAR-SV instance is started to suit the needs of your data center at your own responsibility before ROBAR is used for the first time.

The ROBAR-SV service department will only correct errors arising from an original ROBAR rule file in conjunction with the standard maintenance contract.

The ROBAR-SV Manager offers user-friendly functions for editing ROBAR rule files using the ROBAR editor, see section [“Editing the ROBAR rule files” on page 128](#).

The ROBAR `message_file` and `message_resp` shipped with ROBAR-SV can be adapted to user requirements, i.e. you can make optional entries directly in the relevant file in accordance with the options described in the relevant introduction.

The standard maintenance contract, which otherwise relates only to the ROBAR rule files in their original state, extends to these changes.

Responsibility for changes to the supplied ROBAR rule files that go beyond this must be borne by the person that made them (e.g. additional software vendor).

If the ROBAR rule files are shipped to the customer by an additional software vendor, it is the vendor who is responsible for maintenance of the changes made to the ROBAR rule files. The customer must regulate this in the contracts concluded with these vendors.

The standard maintenance contract covers neither diagnosis nor correction of errors arising from modification of a ROBAR rule file. This type of error must be diagnosed and corrected by the person responsible for the modifications, and not by the ROBAR-SV service.

Support for ROBAR-SV installations with customer-specific ROBAR rule files that goes beyond the general customer support and product range can be offered by the manufacturer within the framework of an additional consultancy agreement or customer-specific project. The same is true for additional support for ROBAR rule files that were obtained from additional software vendors.

The BS2000 file `SYSPAR.ROBAR-CL.<ver>.PROZPARAM` contains default times set for connection monitoring. If these times do not suit your requirements, you can change them before starting ROBAR-CL.

Adding new BS2000 messages

If the message number of the BS2000 system message has not been added to the `SYSPAR.ROBAR-CL.<ver>.MESSAGES` to add new messages to the default files, the operator must:

- terminate the DCAM application `SYSPRG.ROBAR-CL.<ver>.DCAM`, see [page 38](#).
- add the message number of the system message to the `SYSPAR.ROBAR-CL.<ver>.MESSAGES` file (see [page 255](#)).
- if not already done, allocate the routing code of the new message to the DCAM application before ROBAR-CL-DCAM is started (`/ADD-CONSOLE-FILTER` command).
- restart the DCAM application (see [page 37](#)).

The changes to the `SYSPAR.ROBAR-CL.<ver>.MESSAGES` file do not take effect until ROBAR-CL-DCAM is restarted.

Modify ROBAR actions

You can modify and reactivate the ROBAR rule files on the ROBAR server during the current ROBAR session without having to terminate the relevant ROBAR-SV instance.

Delete BS2000 messages

If ROBAR is no longer required to process a BS2000 message, this message should be deleted from the files `message_file` and `message_xref` as well as from the file `SYSPAR.ROBAR-CL.<ver>.MESSAGES`.

If a message is to be deactivated immediately or made ineffective temporarily, the message can be deleted in the `message_file` only.

If the message is deleted from the `SYSPAR` file, it is no longer forwarded to the ROBAR server and therefore the archive system is no longer instructed to react to this message.

Example for modifications in the ROBAR rule file `message_xref`

ROBAR is to deposit cartridges in the output area of the input/output unit for mounting on manually-operated devices. Mount jobs for robot-operated devices should be executed as normal.

Select a new message code from the range of free numbers reserved for you (MFV01) and make the following entries in the `message_xref` file (see also the section [“Special characters in the files” on page 253](#)):

```
:*:MFV01: RC001,MR408;\
MR416;
```

The following actions are performed:

```
:*:MFV01:
```

1.

```
RC001:'<####,MO . ,FFFF,1,r,0mm,vvvvvv,.... >'F
MR408: TYPE % ROB4008 TAPE CARTRIDGE MOUNTED (DEV=mmm / TSN=tttt /
VSN=vvvvvv)
```

2. *In the case of an error*

```
MR416: TYPE % ROB4016 TAPE CARTRIDGE NOT MOUNTED (DEV=mmm /
TSN=tttt / VSN=vvvvvv)
```

Explanations of the ROBAR actions

1. The statements `RC001` and `MR408` are only executed if the device is robot-operated.
2. If an error occurs in the statements `RC001` or `MR408`, the `MR416` statement is executed. This completes job processing for robot-operated devices.

Example of issuing an archive system command from the BS2000 system

Archive system commands which are usually entered using the `MANUAL` menu can also be issued directly from the console. The variables expected by the archive system command must be set.

The operator wishes to output the archive record entry of the cartridge with the VSN `A0001K` on the console.

- The operator issues the following command at the console (see the “Commands” manuals [3]):

```
/SEND=MESSAGE TO=OPERATOR,MESSAGE='<T ULV A0001K'
```

The routing code `T` must be included in the list of routing codes defined in the `SYSPAR.ROBAR-CL.<ver>.PROZPARAM` file under the `TypeRoutingcodes` parameter.

- Select a new message code from the range of free numbers reserved for you (e.g. `MFA99/MRA99`) and make the following entries in the ROBAR rule files so that ROBAR can react to this request:

- in the `message_file` file

```
:*:MFA99: %<T ULV vvvvvv
```

- in the `message_xref` file

```
:*:MFA99: RC007,MRA99
```

The archive system action `RC007` (ULV command) is already in the `roboter_cmds` file; the BS2000 action `MRA99` is redefined:

- in the `message_resp` file

```
MRA99: TYPE          % ROBMA99 ARCHIVE RECORD ENTRY FOR VSN vvvvvv:
                    COORDINATE=aaaaaaaa, STATUS=ss
```

8 Messages

This chapter provides information on the ROBAR-SV messages and on how ROBAR groups the BS2000 messages.

8.1 ROBAR-SV messages

All messages issued by ROBAR-SV on the ROBAR server (including the error logging messages) are created using the standard NLS features. The message texts are now displayed with a leading key, and can therefore be identified for further diagnostic purposes.

8.2 BS2000 messages

The BS2000 messages from ROBAR are divided into the following groups:

- Console messages from ROBAR-SV
These inform the operator of return messages from ROBAR-SV
- Console messages from ROBAR-CL-SDF
These pass information and jobs from ROBAR-CL-SDF to ROBAR-SV
- Messages to SYSOUT and SYSLST
These indicate which actions can(not) be executed and for what reasons

The ROBAR messages, like the BS2000 system messages, consist of

- message code (7 digits, see above)
- attribute line
- message text
- meaning and response text (optional)

The message code has the following format: ROBxxnn

where

xx	the message type: 00 console messages from ROBAR-SV 10 console messages from ROBAR-CL-SDF 11-30 messages to SYSOUT and SYSLST 41-99 messages whose text is defined in the RRF file <code>message_resp</code> and whose output is initiated via ROBAR rule files
nn	serial number of the message (2 digits, 00 to 99)
ROBNxxx	Archive system error code Nxxx (the archive system error codes Nxxx are also defined under the message code ROBNxxx in the ROBAR-CL message file)

Output of messages using /HELP-MSG-INFORMATION

The BS2000 command `/HELP-MSG-INFORMATION MSG-ID=ROBnnnn` allows you to query the meaning and response texts for a message in ongoing operation.



The inserts in the ROBAR-SV messages defined in the `message_resp` file are not actually inserts, the text to be inserted in the message is incorporated with the help of variables (`vvvvvv`, `tttt` etc.; see [page 253](#)).

Output of messages on the internet

You can also find the messages on our manual server using the HTML application in the place of the former “System Messages” manual (URL: <http://manuals.ts.fujitsu.com>) and on the DVD “BS2000 SoftBooks”.

Output of messages using MSGMAKER

The utility routine MSGMAKER enables you to view messages from the ROBAR message file or to output them, see the “Utility Routines” manual [5].

You will find the message file under the file name `SYSMES.ROBAR-CL.<ver>`.

Please ask your local systems support for the user ID which contains the message file.

IMON also allows you to ascertain the file name using the following command:

```
/SHOW-INSTALLATION-PATH INSTALLATION-UNIT=ROBAR-CL, LOGICAL-ID=SYSMES
```

9 Troubleshooting

This chapter describes error situations in the ROBAR system and how you must respond to them. Particular attention is paid to the preparation of diagnostic documents.

If an action causes the archive system to send an error message to ROBAR-SV, ROBAR-SV performs the necessary error recovery actions. The error recovery actions undertaken are of a general character that can also incorporate unnecessary actions (e.g. detachment of a device that has already been detached).

The error recovery actions are used to increase the availability of the archive system. They should not be interpreted as ROBAR errors.

In the majority of cases, the message of the archive system does not display error situations, rather it is used by ROBAR as the basis for executing requested actions. For this reason, such a message is generally not sent to the console. ROBAR checks the message to see whether it is one of the error messages defined in the `error_defines` file. If so, the actions specified there are executed and processing of the BS2000 job is aborted. If the error is not included in the `error_defines` file, the appropriate processing step in the `message_xref` is carried out.

If, on the other hand, the error is an irrecoverable error, the ROBAR message together with the error code of the archive system is sent to the appropriate console.

Information and diagnostic data

The ROBAR-SV Manager displays information on device and volume errors and the error limits for a ROBAR-SV instance. In addition, you can create current diagnostic data and statistics for a ROBAR-SV instance, see [section “Diagnostic information on the ROBAR-SV instance” on page 136](#).

This information is also available via corresponding menus of the `robar` menu program.

9.1 Device and volume error counters

When using the standard ROBAR rule file, ROBAR utilizes device and volume (cartridge) error counters as follows:

1. If an error occurs on a device (usually message `EXC0858`), ROBAR registers the error for the device in question. If a cartridge is mounted in the device at the time the error occurs, then ROBAR also registers an error for the cartridge.
2. When the error has been registered, the error handling procedure appropriate to the error is started (e.g. the cartridge is removed from the device).
3. ROBAR checks the device error counter for the device. If the defined limit (see the `device_error_limit` configuration parameter) has been reached, ROBAR begins with the relevant actions both for the job and for the device. (The actions are provided with default settings, but these can be changed to meet the requirements of your data center.)

- Action key `MRV26` in the ROBAR rule file `message/message_resp` defines the actions for the job. The following possibilities are available:

<code>MOVE</code>	Move the job to another device (default).
<code>CANCEL</code>	Cancel the job.
<code>IGNORE</code>	Ignore the error (i.e. no action).



The action defined with action key `MRV26` is only started if the job affected by the error is still being processed. If, however, an error occurs while a cartridge is being removed, either no job is being processed on the device at that point in time or the job using the device has already changed and is not affected by the error.

If MAREN has caused a `MOUNT` (message `MARxxxx`), the action is not started; the only reaction that is permitted is `tsn.N`.

- Action key `MRV24` in the ROBAR rule file `message/message_resp` defines the actions for the device. The following possibilities are available:

<code>DETACH</code>	Detach the device from the BS2000 system with <code>/DETACH-DEVICE mn, FORCE=*YES</code> (default).
<code>IGNORE</code>	Ignore the error (i.e. no action).



If you select the option `IGNORE`, the device continues to be available to the robot. Any new mount request issued for the cartridge in the course of this job is, however, rejected with the action key `MRV027`.

4. If an error counter exists for the cartridge (see the `volume_error_limit` configuration parameter), ROBAR checks it. If the defined limit has been reached, ROBAR starts the specified actions both for the job and for the cartridge (the actions are supplied with default settings, but you can adjust them to the specific requirements of your data center).

- Action key `MRV27` in the ROBAR rule file `message/message_resp` defines the actions for the job. The following possibilities are available:

`CANCEL` Cancel the job (default).

`IGNORE` Ignore the error (i.e. no action).



The action defined with action key `MRV27` is only started if the job affected by the error is still being processed. If, however, an error occurs while a cartridge is being removed, either no job is being processed on the device at that point in time or the job using the device has already changed and is not affected by the error.

If MAREN has caused a `MOUNT` (`message MARxxxx`), the action is not started; the only reaction that is permitted is `tsn.N`.

- Action key `MRV25` in the ROBAR rule file `message/message_resp` defines the actions for the cartridge. The following possibilities are available:

`EJECT` Place the cartridge in the output area (default).
This option is not available in RRF `CentricStor`.

`IGNORE` Ignore the error (i.e. no action).



If you select `EJECT`, the MTC error counter is reset as soon as the cartridge has been removed.

If you select `IGNORE`, the device continues to be available to the robot. Any new mount request issued for the cartridge in the course of this job is, however, rejected with the action key `MRV027`.

Updating the MAREN catalog

When the error counter of a cartridge (see the `volume_error_limit` configuration parameter) reaches its maximum value, the ROBAR rule file causes the cartridge to be ejected into the input/output unit.

A notification is sent to ROBAR when this situation occurs, and the MAREN catalog is also updated.

Error counters and attached drives

If a device is attached to the system, ROBAR assumes by default that the device works free of errors and that it is empty (i.e. the archive system command `ULK` issues a message indicating that the device is free or a successful `KEEP` command is sent to the archive system). The device error counter is therefore reset in the following cases:

- If a device is empty and its status is “attached and assigned” or “detach pending”, as soon as a connection to a BS2000 system is established
- As soon as an empty device is attached in the BS2000 system

If the device error counter is not to be reset, resetting has to be deactivated by making the necessary modifications to the `MRV28` action key in the ROBAR rule file `message/message_resp`. The following settings are possible:

<code>RESET</code>	Reset the error counter (default).
<code>DO NOTHING</code>	Do not reset the error counter.

Error counters and importing cartridges

By default, ROBAR categorizes an imported cartridge as “new” and automatically resets the error counter for the cartridge.

If you do not want the cartridge’s error counter to be reset, action key `MRV29` in the ROBAR rule file `message_resp` has to be modified accordingly.

The following settings are possible:

<code>RESET</code>	Reset the error counter (default).
<code>DO NOTHING</code>	Do not reset the error counter.

Error counters and foreign cartridge definitions (ABBA interface)

The MTC error counter is reset when a foreign cartridge definition is added or removed.

Preparing a repaired device for use

If a device that has been repaired is to be made operational again, ROBAR requires the relevant information.

Action key `MRV28` of the ROBAR rule file `message_resp` (see [page 273](#)) determines whether the error counter is reset when a device is attached:

- If `MRV28` has the value `RESET`, ROBAR resets the error counter after the device has been attached.
- If `MRV28` has the value `WAIT 0 (DO NOTHING)`, ROBAR must be informed of the successful repair by means of a command input.

Examples

- The device is detached in the BS2000 system
 - The `MRV28` action code has the value `RESET`:
Attach the device in the BS2000 system (`/ATTACH-DEVICE`).
The device error counter and all other error indicators are reset.
 - The `MRV28` action code has the value `DO NOTHING`:
ROBAR must be explicitly informed that the device has been repaired and can thus be used again. To do this, issue the command `/INFORM-OPERATOR MSG='<T DEVICE mmmm REPAIRED'` or `/SEND-MESSAGE TO=OPERATOR,MSG='<T DEVICE mmmm REPAIRED'` (`mmmm` = repaired device). Message `ROB6071` confirms that the device error counter has been reset.
- The device is attached in the BS2000 system
The following action sequences are possible:
 - Sequence allowing unloading if the cartridge can be removed from the device and action key `MRV28` is set to `RESET`:
 - unload the device (`/UNLOAD-TAPE`)
 - detach the device (`/DETACH-DEVICE`)
 - attach the device again (`/ATTACH-DEVICE`)
 ROBAR only resets the device error counter.
 - Sequence that can always be used if the device is attached and the action key `MRV28` is set to `DO NOTHING`.
 - unload the device (`/UNLOAD-TAPE`)
 - detach the device (`/DETACH-DEVICE`)
 - attach the device again (`/ATTACH-DEVICE`)
 - issue the command `/INFORM-OPERATOR MSG='<T DEVICE mmmm REPAIRED'` or `/SEND-MESSAGE TO=OPERATOR,MSG='<T DEVICE mmmm REPAIRED'` (`mmmm` = repaired device)
Message `ROB6071` confirms that the device error counter has been reset.

Preparing a repaired cartridge for use

When a cartridge has been repaired, ROBAR must be informed of the fact.

Action key `MRV29` of the ROBAR rule file `message_resp` (see [page 273](#)) determines whether the error counter is reset when the cartridge is imported:

- If `MRV29` has the value `RESET`, ROBAR resets the cartridge error counter after the cartridge has been imported.
- If `MRV29` has the value `WAIT 0 (DO NOTHING)`, ROBAR must be informed of the successful repair by means of a command input.

Example

The cartridge has been exported, messages concerning its import are available.

- If action key `MRV29` is set to `RESET`, the cartridge error counter is reset when the cartridge is imported.
- When the `MRV29` action code has the value `DO NOTHING`, ROBAR must be explicitly informed that the cartridge has been repaired
(`/INFORM-OPERATOR MSG='<T VOLUME vvvvvv REPAIRED'` or `/SEND-MSG TO=OPERATOR,MSG='<T VOLUME vvvvvv REPAIRED'` command (`vvvvvv` = repaired cartridge)).
Message `ROB6073` confirms that the error counter for the cartridge has been reset.



When entering a message text for the BS2000 commands `INFORM-OPERATOR` and `SEND-MSG`, the syntax rules must be adhered to accurately, in particular the message texts must be written in uppercase letters.

9.2 Robot failure

Only the following action operands should be specified in the `error_defines` file: `ATOP`, `EXIT`, `AEXIT`, `STOP`, `ASTOP` and `TIME`.

If a robot fails, the operator must mount the MTCs on the appropriate devices. Make sure that there are no inconsistencies arising in the archive record. The following options are available:

- The operator responds to the display of the devices by mounting the MTCs and placing them in the archive system input unit once they have been unloaded. When the archive system has started up, the archive system command `INSERT` is issued manually to “tidy up” the MTCs.

Disadvantage

The running ROBAR processes must be terminated and the MTCs just mounted must be added to the archive record by hand.

- The operator responds to the display of the devices by mounting the MTCs on the devices and, once they have been unloaded, returning them to their original location. It is not necessary to update the archive record in this case.

Disadvantage

Here, too, the running ROBAR processes must be terminated (`STOP` menu). When the archive system is restarted, the MTCs just mounted must be added to the archive record entry by hand.



Operator intervention is not always required if a robot fails for a short period only, since cumulated BS2000 console messages of type ? are fetched using ROBAR and processed by ROBAR after the RESTART.

9.3 Severance of the connection between ROBAR-SV and BS2000

Disruptions of connections between a ROBAR-SV instance and the BS2000 systems are reported both on the information pages of the ROBAR-SV Manager and in the menu window of the `robar` menu program (see [page 151](#)).

If the connection between ROBAR-SV and a BS2000 system is severed, ROBAR reacts as follows.

- All jobs of the BS2000 system to which the connection has been severed are deleted from the job file of the ROBAR-SV instance. Thereafter ROBAR makes regular attempts to re-establish the connection.
- Following a successful connection setup, ROBAR-SV sends all messages to ROBAR-CL that have not yet been transferred. Subsequently ROBAR requests information on the allocated devices and their assignment as well as on open BS2000 jobs still to be processed. It then begins normal processing of these jobs.
- Proceed as follows should the attempt to establish the connection fails:
 - terminate ROBAR-CL-DCAM in the BS2000 system
 - terminate all the ROBAR-SV instances, then log off from the ROBAR server
 - log on to the ROBAR server again, start the ROBAR-SV instances again
 - restart ROBAR-CL-DCAM in the BS2000 system
- Each time the connection is severed between the BS2000 system and the ROBAR server, the current BS2000 trace file is closed. Once the connection has been set up again, a new trace file displaying the current time stamp is created.
- In the case of saturation states (Grade 2 and higher) in the paging area of a BS2000 system, operation with ROBAR-CL is stopped. It is resumed automatically when the saturation state has terminated.

9.4 Failure of the ROBAR server

In this case you can enter the mount/dismount statements for the archive system directly on the archive system.

At the SCSI interface the archive record is not available during this time and consequently becomes inconsistent. The next time a ROBAR-SV instance is started, a new archive record is generated.

9.5 Defective MTC devices

If, due to a hardware error, a cartridge cannot be removed from a MTC device despite an “emergency unload” and RESET attempts, the device should remain attached to the BS2000 system until the cartridge has been removed manually. This prevents the tape request being reassigned to a different MTC device and this other device being reserved for the unavailable cartridge. The defective device may therefore only be detached once the cartridge has been removed from the device and, if it can still be used, the archive system has once more been made available.

The ROBAR-SV instance, that operates the device, must be terminated and restarted to update the status of the devices in the archive system. At the SCSI interface a new archive record is automatically generated when the ROBAR-SV instance is started; at the ABBA interface it must be corrected appropriately.

A ROBAR rule file option permits the deletion of the original request and the detachment of the device reserved for the request. This option can have undesired effects on the requesting job and should therefore be avoided (action key MRV22 in `message_resp`).

ROBAR frequently reacts to a defective MTC device (hardware error) by issuing the command `/CHANGE-TAPE-MOUNT ACTION=*MOVE`, i.e. by swapping a device, and by controlled deactivation of defective units. However a device can only be swapped if a further MTC in the archive device is available. For this reason, the robot should administer **at least two** MTC devices.

Limits of troubleshooting

Errors in the MTC devices or in neighboring hardware and software components that cannot be detected by means of messages directed to the console cannot be detected by ROBAR either. Errors of this type must be corrected directly in the hardware and software components (e.g. MTC devices, BS2000 components) by the operator or within the provisions of the maintenance agreement.

Support of MTC devices by BS2000 outside of the archive system and physical support by the archive systems does **not** mean that these MTC devices are also supported by ROBAR.

To support a device, ROBAR requires a high level of reliability for the interplay of the hardware, firmware and software components in order to be able to guarantee uninterrupted tape processing in robot operation.

The standard scope of maintenance from the manufacturer therefore covers only those devices which are supported by ROBAR, see the archive system-specific sections “[MTC devices and cartridges](#)” in section “[Archive systems](#)” on page 26.

9.6 Input/output area overflow during cartridge transfer

If an EJECT command cannot be executed because of a full input/output area during cartridge transfer, the archive system returns error code N503 to ROBAR. The following PAUSE message is then output to the relevant BS2000 system:

```
ROB0035 I/O UNIT FULL --> PLEASE REMOVE CARTRIDGES
```

The rejected job is entered in the file: `.../cmx/robar.eject`.

The open MAREN or ROBAR-CL messages are not answered.

As soon as the input/output area is empty, ROBAR must be informed accordingly by means of the following command:

```
/SEND-MSG TO=OPERATOR,MSG='<T I/O-BOX EMPTY'
```

If the SEND-MSG command is issued too early, error code N503 is output to ROBAR once again and the operation is repeated.

Open MAREN or ROBAR-CL messages are answered once the unload operation is concluded.

9.7 Preparing documents for diagnosis

If errors occur in the ROBAR system, e.g. the robot fails completely or partially to execute a required action, it is important that the technical support staff receives diagnostic data.

As ROBAR runs under both the BS2000 system and under the ROBAR server, the diagnostic data for both operating systems - starting at the same time - are required.

Each time the connection between a BS2000 system and a ROBAR-SV instance is interrupted, the current BS2000 trace file is assigned the current time stamp, closed, and a new trace file is opened. Once the connection has been set up again, the ROBAR actions are logged in this trace file.

9.7.1 Diagnostic documentation for a BS2000 system

The following files are required from the BS2000 system for diagnosis:

- detailed description of the error situation; the sequence of operations is required for a reproducible error
- CONSLOG: console log
- the SYSOUT file created (under any name) in the start file by ROBAR
- SYSPAR.ROBAR-CL.<ver>.MESSAGES
file for the messages relevant to ROBAR
- \$<userid>.ROBAR.TRACE.<partner>.<date>
the trace files created by ROBAR-CL-DCAM with date and time
- user dump, if any.

If you use the HSMS/ARCHIVE program to store these files on tape, also provide the backup listing.

Note

The start procedure for ROBAR-CL-DCAM generates different file names for the SYSOUT output of ENTER jobs:

- When SDF-P is installed, the SYSOUT file
SYSRPT.ROBAR-CL.<ver>.<DCAM-name>.<tsn> is generated for each new TSN. These files must be deleted regularly to avoid saturating the disk space.
- When SDF-P is not installed, the
SYSOUT file SYSRPT.ROBAR-CL.<ver>.<DCAM-name>.SYSOUT is generated. A new file with this name is generated each time ROBAR-CL is started.

9.7.2 Diagnostic documentation for the ROBAR server

You have various options for collecting diagnostic data of the ROBAR-SV instances:

- with the ROBAR-SV Manager (recommended)
- using scripts
- with the `robar` menu program

Collecting diagnostic documentation with the ROBAR-SV Manager

You can use the ROBAR-SV Manager to collect and display current diagnostic data for a ROBAR-SV instance in a user-friendly manner, see [section “Diagnostic information on the ROBAR-SV instance” on page 136](#).

Collecting diagnostic documentation using a script

The interface-specific scripts `COLLECT_DIAG_DATA_<interface>` support you in collecting all the required diagnostic documentation. The diagnostic data is automatically selected by ROBAR-SV.

Format:

```
COLLECT_DIAG_DATA_SCSI [-a <directory>] [-d <directory>] <instance>  
COLLECT_DIAG_DATA_ABBA [-a <directory>] [-d <directory>] <instance>
```

Operands:

`-a <directory>`

Optional specification of a directory with further data which is added to the diagnostic documentation collected by the script.

`-d <directory>`

Optional specification of a directory in which the diagnostic documentation collected by the script is stored.

Without this specification the diagnostic documentation is stored in the directory specified in the `ROBAR_SAVE_DIR` parameter of the global configuration file of ROBAR-SV (default value: `/var/opt/fujitsu/robar`).

If the the diagnostic documentation cannot be stored there, it is stored in the `/var/opt/fujitsu/robar` directory.

`<instance>`

Name of the ROBAR-SV instance for which the diagnostic documentation is to be created.

Collecting diagnostic documentation with the `robar` menu program

You can create diagnostic documentation with the `SAVE` menu. For more details on the `SAVE` menu, see [page 179](#).

9.7.3 Problems with the TCP/IP connection (ABBA interface)

Should a problem occur in conjunction with the TCP/IP connection between ROBAR-SV and the archive system, the following information must be obtained:

- output of the `env` command
- output of the `ping <robot ip address>` command
- output of the `ps -ef | grep <instance>` command for all active ROBAR-SV instances
- output of the `netstat -a` command
- diagnostic documentation of the active ROBAR-SV instances (see above).
If the configuration parameter `LTRACE=YES` (see [page 215](#)) is set, supplementary connection information is stored in the trace files.

10 Appendix

This appendix describes ROBAR trace files and ROBAR statistics. It includes examples and provides explanations of the file structure.

10.1 ROBAR-CL trace file

For ROBAR-CL-DCAM (BS2000), logging to trace files is activated when the program `SYSPRG.ROBAR-CL.<ver>.DCAM` is called. The program is called with the start procedure `SYSPRC.ROBAR-CL.<ver>`. Specifying the parameter `TRACE-NBR=<n>` defines the number of trace entries. `<n>` defines the number of records written to the trace file; the value 0 (default value) means that no trace files are generated). No trace files are generated if the parameter is not specified.

The file attributes of primary and secondary file assignments can be defined via the parameters `PRIMARY=PP` und `SECONDARY=PP`. By default `PRIMARY=60` and `SECONDARY=30`. Both values must be matched to the number of records that are to be written to a trace file (`TRACE-NBR=<n>` parameter).

The trace files are created by default under the current user ID. The parameter `TRACE` in the start file allows you to create the files for a specific user ID (e.g. `$TRA`) and with a specific prefix (e.g. `ROBTRACE` instead of `ROBAR`)(`TRACE=$TRA.ROBTRACE`). The trace file is generated by default under the following name:

```
$TSS0S.ROBAR.TRACE.<DCAM-name>.<tsn>.<day>-<hour><minute>[.<seq_no>]
```

Once the defined number of written records is reached, the file is swapped automatically. If the file is swapped in the same minute as the previous trace file was generated, a catalog entry for a file whose name element `<seq_no>` is increased by 1 is generated (this should be a rare occurrence if a sufficiently large value was selected for the `TRACE-NBR` parameter).

The ROBAR-CL start procedure deletes trace files which were created more than 7 days ago.

10.2 ROBAR-SV trace files

In addition to internally-used files, ROBAR-SV creates the following trace files in the `/var/lib/<interface>/<instance>/trace` directory:

- `robar.trace[.<time_stamp>]`
- `vbs2.trace[.<time_stamp>]`
- `nbs2.trace[.<time_stamp>]`

These files can be evaluated using the LIST menu (see [page 165](#)). The structure of the entries is described in the following sections.

10.2.1 robar.trace

All actions of ROBAR and all reactions of the archive system are logged in the file `robar.trace`. Statistics can then be generated from this `robar.tracefile` (see [section “ROBAR statistics” on page 341](#)).

Extract from a trace file (ABBA interface).

Example

```
RSV1057 Trace file (ROBAR ver>) created at : <date> <time>
<070628150356> RSV1055 ROBAR session started
                with EKS status 0, Configuration file test_sdlic_lto
<070628150400> <--MAN : H 1 SSS100 START      <S100,ACOM, ,ffff,1, ,
, vvvvvv, , aaaaaaaaa, bbbbbbbb, uuuuuuuuu>
<070628150400> -->ROB : H 1 SSS100 START      <S100,ACOM, , , ,1, , ,
, , , , ,28/150400>
<070628150400> <--ROB : H 1 SSS100 START      <S100,ACOM,P,M701,1, ,
, V03.11, ,501A , NOTREADY,28/150400>
<070628150400> -->CFG :                      AMU = ACTIVE _____ (1)
<070628150400> -->CON : HD0 DDS100 ALLP
                % ROB0045 AMU-STATUS IS >ACTIVE< _____ (2)
<070628150400> -->CFG :                      ROB1 = ON
<070628150400> <--MAN : H SSS101 START      <S101,ULK , ,ffff,1, ,
, vvvvvv, ss, 00000000, , uuuuuuuuu>
<070628150400> -->ROB : H SSS101 START      <S101,ULK , , ,1, , ,
, , 00000000, ,28/150400>
<070628150400> <--ROB : H SSS101 START      <S101,ULK ,N,N401,1, , ,
, , 00000000, ,28/150400>
<070628150400> <--MAN : H SSS102 START      <S102,ULK , ,ffff,1, ,
, vvvvvv, ss, 0000TF01, , uuuuuuuuu>
<070628150400> -->ROB : H SSS102 START      <S102,ULK , , ,1, , ,
, , 0000TF01, ,28/150400>
```

```

<070628150400> <--ROB : H SSS102 START <S102,ULK ,N,N401,1, , ,
, ,0000TF01, ,28/150400>
<070628150400> <--MAN : H SSS103 START <S103,ULK , ,ffff,1, ,
,vvvvvv,ss,0000TG01, ,uuuuuuuuuu>
<070628150400> -->ROB : H SSS103 START <S103,ULK , , ,1, , ,
, ,0000TG01, ,28/150400>
<070628150401> <--ROB : H SSS103 START <S103,ULK ,N,N401,1, , ,
, ,0000TG01, ,28/150400>
<070628150401> <--MAN : H SSS104 START <S104,ULK , ,ffff,1, ,
,vvvvvv,ss,0000TH01, ,uuuuuuuuuu>
<070628150401> -->ROB : H SSS104 START <S104,ULK , , ,1, , ,
, ,0000TH01, ,28/150401>
<070628150401> <--ROB : H SSS104 START <S104,ULK ,P, ,1,1,
,FREI00,0L,0000TH01, ,28/150401>
<070628150401> <--MAN : H SSS105 START <S105,ULK , ,ffff,1, ,
,vvvvvv,ss,0000TI01, ,uuuuuuuuuu>
<070628150401> -->ROB : H SSS105 START <S105,ULK , , ,1, , ,
, ,0000TI01, ,28/150401>
<070628150401> <--ROB : H SSS105 START <S105,ULK ,P, ,1,1,
,FREI00,0L,0000TI01, ,28/150401>
<070628150401> <--MAN : H SSS106 START <S106,AUTO, ,ffff,1,r, ,
, , , ,uuuuuuuuuu>
<070628150401> -->ROB : H SSS106 START <S106,AUTO, , ,1, , ,
, , , ,28/150401>
<070628150401> <--ROB : H SSS106 START <S106,AUTO,P, ,1, , ,
, , , ,28/150401>
<070628150401> <--MAN : H 1 SSS107 START <S107,ROSA, ,ffff,1,1, ,
, , , ,uuuuuuuuuu>
<070628150401> -->ROB : H 1 SSS107 START <S107,ROSA, , ,1,1, ,
, , , ,28/150401>
<070628150401> <--ROB : H 1 SSS107 START <S107,ROSA,P, ,1,1,
,V03.11, ,501A ,NOTREADY,28/150401>

```

- (1) Communication with the archive system is started (ACOM).
- (2) The "active" status of the archive system is reported to the BS2000 console (-->CON).
- (3) The status of the MTC devices administered by ROBAR is checked (ULK).
- (4) The robot is set to automatic (AUTO) and started (ROSA).

```

<070628150433> <--CON : HS1 SAT002 D17Z19   ROBA START-ATT TH
MFSAT
<070628150433> -->CFG : HS1 SAT002 D17Z19   'TH' attached
<070628150433> -->CON : HS1 SAT002 D17Z19   % ROBOSAT FROM ROBAR VIEW
TAPE CARTRIDGE TH   DEVICE IS ATTACHED
<070628150433> <--CON : HS1 SAT003 D17Z19   ROBA START-ATT TI
MFSAT
<070628150433> -->CFG : HS1 SAT003 D17Z19   'TI' attached
<070628150433> -->CON : HS1 SAT003 D17Z19   % ROBOSAT FROM ROBAR VIEW
TAPE CARTRIDGE TI   DEVICE IS ATTACHED _____ (5)
<070628150433> <--CON : HS1 SMT002 D17Z19   ROBA START-EMPTY TH
MFSMT
<070628150433> <--CON : HS1 SMT003 D17Z19   ROBA START-EMPTY TI
MFSMT _____ (6)
<070628150618> <--CON : NS1 000001 D17Z19   OHDM ?NKVT013 000062 TH
SPECIAL LIST TAPE-U2 ,VSN=000062           MF023 _____ (7)
<070628150618> -->ROB : NS1 000001 D17Z19   <0001,MO , ,
,1,1,0TH,000062, 1, , ,28/150618> _____ (8)
<070628150631> <--ROB : NS1 000001 D17Z19   <0001,MO ,P,
,1,1,0TH,000062, 1,01020803,00000301,28/150618> _____ (9)
<070628150631> -->CON : NS1 000001 D17Z19   % ROB4008 TAPE CARTRIDGE
MOUNTED (DEV=TH / TSN=OHDM / VSN=000062) _____ (10)
<070628150640> <--CON : HS1 000002 D17Z19   TM %NKVT010 000062 TH
MF009 _____ (11)

```

- (5) The RRF entry MFSAT (START-ATTACH) is called for the devices TH and TI which are recognized as attached.
- (6) No volume is mounted on the devices TH and TI. The RRF entry MFSMT (START-EMPTY) is consequently called.
- (7) Message NKVT013 must be processed. The corresponding RRF entry in this case is MF023.
- (8) ROBAR instructs the archive system to mount the requested cartridge 000062 on the device TH.
- (9) The archive system reports that cartridge 000062 has been mounted successfully (P for "positive") on the device TH.
- (10) ROBAR reports the successful mounting operation to the BS2000 console (ROB4008).
- (11) The Tape Monitor Task (TM) reports that the label (tape label, SVL) of cartridge 000062 has been read successfully on the device TH. The RRF entry MF009 is called.

```

<070628150640> <--CON : NS1 000003 D17Z19      OHDM %NKVT017 TH
MF017 _____ (12)
<070628150645> <--CON : NS1 000004 D17Z19      TM %NKVT097 000062 TH
MF005 _____ (13)
<070628150645> -->ROB : NS1 000004 D17Z19 <0004,KE , , ,1,1,0TH,
, , , ,28/150645>
<070628150716> <--ROB : NS1 000004 D17Z19 <0004,KE ,P,
,1,1,0TH,000062, ,00000301,01020803,28/150645> _____ (14)
<070628150716> -->CON : NS1 000004 D17Z19 % ROB4004 TAPE CARTRIDGE
DEVICE UNLOADED (DEV=TH / VSN=000062) _____ (15)

```

- (12) The BS20000 system reports NKVT017: the cartridge 000062 is now assigned to the task OHDM. The RRF entry MF017 is called.
- (13) The BS20000 system reports the unloading of the cartridge 000062 on the device TH (NKVT097). The RRF entry MF005 is called.
- (14) ROBAR causes the cartridge to be removed from the device and returned to its storage location (KE). This operation is acknowledged positively (P).
- (15) ROBAR reports the successful removal of the cartridge 000062 from the device TH to the BS2000 system with message ROB4004.

Meaning of entries

Column

```

1           17           27 29 31    38           48
|           |           | | |      |           |
<070628150631> -->CON :  NS1 000001 D17Z19    %  ROB4008 TAPE CARTRIDGE
MOUNTED (DEV=TH / TSN=0HDM / VSN=000062)

```

Col. 1:	Time stamp	(Format: <yymmddhhmms>)
Col. 17:	Sender/receiver	
	<--CON:	Message from BS2000 operator's console to ROBAR
	-->CON:	Message from ROBAR to BS2000 operator's console
	<--MAN:	Message from MANUAL mode (see page 171) or start operation
	<--ROB:	Message from the archive system to ROBAR
	-->ROB:	Message from ROBAR to the archive system
	-->ATOP:	Message from ROBAR to the automatic operator
	-->CFG:	Configuration update (ATT/DET)
	INPUT:	Confirmation in simulation mode
	IGNORED:	Message has been ignored
	WARNING:	Timeout, barcode not readable, etc.
	REPEAT:	Job has been pended
	RESTART:	Restart
Col. 27:	Column identifier (H (high) = prioritized job, L (low), N (normal))	
Col. 29:	Robot number	
Col. 31:	Job number (the last 4 digits are transferred to the archive system command)	
	nnnnnn:	BS2000 job (6-character, numeric)
	MMnnnn:	Manually entered job (MANUAL)
	SSnnnn:	Job from connection setup
Col. 38:	Job submitter	
	xxxxxx:	Name of the BS2000 system
	ALLP:	All BS2000 systems
	ROBAR:	ROBAR system (MANUAL mode)
	START:	ROBAR system (connection setup)
Col. 48:	Action or reaction (archive system command, return code, message text, etc.)	

10.2.2 vbs2.trace

All connection-relevant information and all messages emanating from ROBAR-CL are logged in the file `vbs2.trace`.

First, the device allocation is queried for each BS2000 system setting up a connection (`SHOW-DEVICE-STATUS` with `TYPE=MBK` and `ATTRIBUTE=ATTACHED`, see “Introduction to System Administration” [2]).

If no device is attached in the BS2000 system `<<MNEM;L VSN>>`, else `<<MNEM;L VSN>;<TH;>;<TI;>>` is logged to the trace file (see also example on the next page).

Then, during the rest of the ROBAR session, a trace entry is generated for every message which leads to a ROBAR job.

Extract from a `vbs2.trace` file.

The file corresponds to the trace file on [page 332](#).

Example

RSV1057 Trace file (ROBAR ver>) created at : <date> <time>

<070628150356> RSV1055 ROBAR session started

<070628150408> 1. START: partner-id = PAD5EDXX

<070628150433> PAD5EDXX: SHOW-DEV <<MNEM;L VSN>;<TH;>;<TI;>>

<070628150433> SYSSTART: partner-id = PAD5EDXX, host = D17Z19, status = A

<070628150433> PAD5EDXX: TH ATTACHED

<070628150433> PAD5EDXX: TI ATTACHED

<070628150618> PAD5EDXX: <NKVT013;?;0HDM;000062;TH; ;SPECIAL;LIST TAPE-U2 ,VSN=000062>

<070628150640> PAD5EDXX: <NKVT010;%; TM;000062;TH>

<070628150640> PAD5EDXX: <NKVT017;%;0HDM;TH>

<070628150645> PAD5EDXX: <NKVT097;%; TM;000062;TH>

```

|           |           |
1           17           28
    
```

Column

Meaning of entries:

Col. 1:	Time stamp	(Format: <yymmddhhmss>)
Col. 17:	1. START :	for the 1st BS2000 system that sets up a connection
	RESTART :	for the 2nd and all subsequent BS2000 systems that set up a connection
	SYSSTART :	A connection has been set up as a result of a SHOW-DEVICE-STATUS command
	SYSEND :	Close connection
	----- :	Message is not processed by ROBAR
	xxxxxxx :	TNS remote name of BS2000 host (message is processed by ROBAR)
Col. 28:	Console message, or for 1. START, SYSSTART and SYSEND: partner-id =TNS partner name, host = host name status =A (connection set up) or D (connection closed)	

10.2.3 nbs2.trace

All active connections, all BS2000 systems and the messages from ROBAR-SV to ROBAR-CL are logged to `nbs2.trace`.

Extract from to `nbs2.trace` file.

The file corresponds to the trace file on [page 332](#).

Example

RSV1057 Trace file (ROBAR ver>) created at : <date> <time>

```
<070628150356> RSV1055 ROBAR session started
<070628150408> 1. START: partner-id = PAD5EDXX
<070628150408> -->CON : PAD5EDXX #DevList <TF;TG;TH;TI> _____ (1)
<070628150408> -->CON : PAD5EDXX #ErrList
<IVRQ;EQCH;INOP;LDCK;READ;SEQU;RAWR;EMPT;UNRC;DSEE;IOER;NINT;RCNF;CSBE;EBM;
BUSY;NAIN;CLRQ;OVER;CUTE>
<070628150408> -->CON : PAD5EDXX #ErrList
<IDCK;BOPE;ALRS;BOEX;CALG;CMDR;COEX;DTCK;EODM;EXEX;IFCK;LIBE;NASG;NCAP;PREX;
PROT;RSET;UATT;WREJ> _____ (2)
<070628150408> -->CON : PAD5EDXX MARKER AFTER CONSTART
<070628150408> *****: <;C;<T % % ROB0045 AMU-STATUS IST >ACTIVE<>
<070628150408> PAD5EDXX: <;C;MARKER AFTER CONSTART>
<070628150433> PAD5EDXX: <;C;<T % % ROBOSAT FROM ROBAR VIEW TAPE
CARTRIDGE TH DEVICE IS ATTACHED>
<070628150433> PAD5EDXX: <;C;<T % % ROBOSAT FROM ROBAR VIEW TAPE
CARTRIDGE TI DEVICE IS ATTACHED>
<070628150631> PAD5EDXX: <;C;<T % % ROB4008 TAPE CARTRIDGE MOUNTED
(DEV=TH / TSN=0HDM / VSN=000062)>
<070628150716> PAD5EDXX: <;C;<T % % ROB4004 TAPE CARTRIDGE DEVICE
UNLOADED (DEV=TH / VSN=000062)>
```

- (1) ROBAR-SV transfers a list of the devices (the mnemonic device names TF, TG, TH, TI) operated by the ROBAR-SV instance concerned to ROBAR-CL.
- (2) ROBAR-SV transfers a list of the error codes (inserts of the EXC0858 message) which are relevant for the ROBAR-SV instance concerned to ROBAR-CL in two separate jobs.

Meaning of entries

Column

```

1           17           28
|           |           |
<070628150408>  -->CON :   PAD5EDXX  MARKER AFTER CONSTART
<070628150716>  PAD5EDXX: <;;C;<T  %%  ROB4004 TAPE CARTRIDGE DEVICE
                               UNLOADED (DEV=TH  / VSN=000062)>
    
```

Col. 1:	Time stamp	(Format: <yymmddhhmms>)
Col. 17:	-->CON:	Message from ROBAR-SV to ROBAR-CL when a connection is set up to transfer the list of relevant devices (#DevList) and error codes (#ErrList) of this ROBAR-SV instance
	SYSSTART :	for the 1st BS2000 system that sets up a connection
	RESTART :	for the 2nd and all subsequent BS2000 systems that set up a connection
	SYSEND :	Close connection
	xxxxxxxx :	Message is sent to the BS2000 host defined by its TNS remote name
	***** :	Message is sent to all attached BS2000 hosts
Col. 28:	BS2000 action, or for SYSSTART, RESTART and SYSEND: partner-id =TNS partner name	

10.3 ROBAR statistics

ROBAR statistics are compiled from the information collected in the `robar.trace` files. The statistics are described and explained below.

You can use the ROBAR-SV Manager to display the statistics for a ROBAR-SV instance, see section [“Outputting ROBAR statistics” on page 138](#). In this case you can specify multiple trace files and a period for evaluation.

Statistics are gathered from a trace file over a specifiable period using the `EVAL` parameter in the `LIST` menu of the `robar` menu program.

After specifying the trace file(s) and the desired period, the statistics described below can be compiled using the listed parameters:

Summary statistics	<code>SUM</code> parameter
Host statistics	<code>HOST</code> parameter
Statistics on manual inputs	<code>MAN</code> parameter
Cleaning statistics	<code>CLEAN</code> parameter
IMPORT/EXPORT statistics	<code>IMP/EXP</code> parameter
Inventory statistics	<code>INV</code> parameter
Error statistics	<code>ERROR</code> parameter

10.3.1 Summary statistics

Summary statistics are compiled using the `SUM` parameter.

They provide information on:

- Which archive system command was executed and how often
- What the response of the archive system to the command was (positive/negative response)
- Number of warnings
- Job number

Example

ROBAR <version>

<date>

SUMMARY STATISTICS

1. Analysis file : /var/lib/robar_abba/robtst2/trace/robar.trace

Analysis period : <date> <time> - <date> <time>

ABBA-CMD	#CMD	#RESP	#POS.	#NEG.	#WARN	TID
ACOM	00001	00001	00001	00000	00000	
ULK	00022	00022	00022	00000	00000	
AUTO	00001	00001	00001	00000	00000	
ROSA	00001	00001	00001	00000	00000	
MO	00209	00209	00208	00001	00000	
	[barcode label not readable]	[T4,RD3301]	N304			0153
KE	00209	00209	00207	00002	00000	
	[cartridge cannot be remove]	[T4,SPCC08]	N206			0170
	[cartridge cannot be remove]	[T4,SPCC08]	N206			0170
EJ	00012	00012	00011	00001	00000	
	[volser not in library] [03,STK002]	N302			1859
IN	00007	00014	00014	00000	00000	

where

Heading	Meaning
ABBA-CMD	Archive system command
#CMD	Number of archive system commands from ROBAR to the archive system
#RESP	Number of responses from the archive system to ROBAR
#POS.	Number of positive responses
#NEG.	Number of negative responses
#WARN	Number of warnings
TID	Job number (task identifier, bytes 2-5 in the archive system command)

10.3.2 Host statistics

Host statistics are compiled using the `HOST` parameter.

They provide information on:

- which BS2000 system initiated which archive system command
- what the response of the archive system to the command was (positive/negative response)
- Number of warnings
- job number

Example

ROBAR <version>

<date>

HOST STATISTICS

1. Analysis file : /var/lib/robar_abba/robtst2/trace/robar.trace

Analysis period : <date> <time> - <date> <time>

HOST	ABBA-CMD	#CMD	#RESP	#POS.	#NEG.	#WARN	TID
VM3-2	ULK	00006	00006	00006	00000	00000	
	MO	00006	00006	00006	00000	00000	
	KE	00006	00006	00006	00000	00000	
TIF-2	ULK	00009	00009	00009	00000	00000	
	MO	00221	00221	00220	00001	00000	
	[barcode label not readable]			[T4,RD3301]	N304		0153
	KE	00220	00220	00218	00002	00000	
	[cartridge cannot be remove]			[T4,SPCC08]	N206		0170
	[cartridge cannot be remove]			[T4,SPCC08]	N206		0170
	EJ	00010	00010	00009	00001	00000	
	[volser not in library]			[03,STK002]	N302		1859
	IN	00009	00009	00009	00000	00000	

```

-----
VM2-2  M0      00002  00002  00002      00000  00000
        KE      00002  00002  00002      00000  00000
        ULK     00006  00006  00006      00000  00000

```

```

-----
VM4-2  ULK     00001  00001  00001      00000  00000
        M0      00002  00002  00002      00000  00000
        KE      00002  00002  00002      00000  00000

```

where

Heading	Meaning
HOST	Name of the BS2000 system
ABBA-CMD	Archive system command
#CMD	Number of archive system commands from ROBAR to the archive system
#RESP	Number of responses from the archive system to ROBAR
#POS.	Number of positive responses
#NEG.	Number of negative responses
#WARN	Number of warnings
TID	Job number (task identifier, bytes 2-5 in the archive system command)

10.3.3 Statistics on manual inputs

Manual inputs are inputs sent to the archive system using the `MANUAL` menu.

Statistics on manual inputs are compiled using the `MAN` parameter.

They provide information on:

- which archive system command was executed and how often
- what the response of the archive system to the command was (positive/negative response)
- Number of warnings
- job number

Example

```
ROBAR <version>                                     <date>
```

STATISTICS ON MANUAL INPUTS

```
1. Analysis file : /var/lib/robar_abba/robtst2/trace/robar.trace
Analysis period : <date> <time> - <date> <time>
```

```
ABBA-CMD    #CMD    #RESP          #POS.    #NEG.    #WARN    TID
=====
KE          00001   00001          00001    00000    00000
```

where

Heading	Meaning
ABBA-CMD	Archive system command
#CMD	Number of archive system commands from ROBAR to the archive system
#RESP	Number of responses from the archive system to ROBAR
#POS.	Number of positive responses
#NEG.	Number of negative responses
#WARN	Number of warnings
TID	Job number (task identifier, bytes 2-5 in the archive system command)

10.3.4 Cleaning statistics

Cleaning statistics are compiled using the `CLEAN` parameter. They provide information on how often each cleaning cartridge is mounted on each device, and how often the device itself has been cleaned.

Example

```
ROBAR <version>                                     <date>
                                           CLEANING STATISTICS
```

```
1. Analysis file : /var/lib/robar_abba/robtst2/trace/robar.trace
Analysis period : <date> <time> - <date> <time>
```

Cleaning cartridges

```
VSN:      *CL001      *CL002
```

```
-----
#MOUNT    0001      0002
```

Device Cleaning

```
MN:       M0        M1
```

```
-----
#CLEAN    0001      0002
```

where

Heading	Meaning
VSN	VSN of the cleaning cartridge
#MOUNT	Number of times the cleaning cartridge has been mounted
MN	Device mnemonic of the MTC device (in the above example: M0, M1)
#CLEAN	Number of times the device has been cleaned

10.3.5 IMPORT/EXPORT statistics

The IMPORT/EXPORT statistics are compiled using the `IMP/EXP` parameter. They provide information on the number of successful and unsuccessful cartridge imports (inserts) and exports (ejects) of the archive system.

Example

```
ROBAR <version>                                     <date>
```

IMPORT STATISTICS

```
1. Analysis file : /var/lib/robar_abba/robtst2/trace/robar.trace
Analysis period : <date> <time> - <date> <time>
```

```
POS. INSERT : 00018          NEG. INSERT : 00000
```

```
-----
STK004, TST028, STK001, STK005, STK002, STK003,      ,      ,
      , STK002,      , STK002,      ,      , STK002,
```

EXPORT STATISTICS

```
POS. EJECT  : 00009          NEG. EJECT  : 00001
```

```
-----
STK005, STK001, STK002, STK003, STK004, STK002, STK002, STK002
```

```
NEG. EJECT  :
```

```
-----
STK002
```

where

Heading	Meaning
POS. INSERT	Number of successful imports
NEG. INSERT	Number of unsuccessful imports
POS. EJECT	Number of successful exports
NEG. EJECT	Number of unsuccessful exports

10.3.6 Inventory statistics

In the archive system an inventory is defined as a comparison of the current status of the archive with the archive record. An inventory is made using archive system commands (e.g. `IVK` command in the `MANUAL` menu).

The inventory statistics are compiled using the `INV` parameter. They provide information on discrepancies between the current status and the archive record. The storing position at which an error has been detected and the archive number of the cartridge entered in the archive record are reported.

The archive number of the cartridge actually present at the storing position is not reported.

Example

```
ROBAR <version>                                     <date>

                                INVENTORY STATISTICS
```

```
1. Analysis file : /var/lib/robar_abba/robtst2/trace/robar.trace
Analysis period : <date> <time> - <date> <time>
```

```
ABBA-CMD
=====
```

where

Heading	Meaning
ABBA-CMD	Archive system inventory error messages

10.3.7 Error statistics

Error statistics are compiled using the `ERROR` parameter.

They provide information on:

- the number of errors that have occurred in the archive system
- the archive system error code and error message

Example

ROBAR <version>

<date>

ERROR STATISTICS

1. Analysis file : /var/lib/robar_abba/robtst2/trace/robar.trace

Analysis period : <date> <time> - <date> <time>

```
Count      ERR#      Error text
=====
0001      N304      [barcode label not readable]
0002      N206      [cartridge cannot be removed]
0001      N302      [volser not in library   ]
```

where

Heading	Meaning
Count	Number of errors that have occurred
ERR#	Archive system error code
Error text	Archive system error message

Glossary

ABBA interface

Defines how the virtual archive system ETERNUS CS is controlled by ROBAR.

actions

Actions are defined by the user in the [ROBAR rule files \(RRFs\)](#) for every BS2000 console message, and consist of:

- [archive system](#) actions (mounting, dismounting cartridges etc.)
- BS2000 system actions (responding to console messages etc.)

archive numbers

Each cartridge has a 6-digit archive number under which it is known in the archive system. This number must be identical with the volume serial number (VSN) with which the cartridge was initialized in the BS2000 system. The VSN is the identifier by which the cartridge is known to the BS2000 system. In this manual the terms “archive number” and “VSN” are used synonymously. “Archive number” may not be confused with the “number of the archive”.

archive record (also: archive database)

Database containing the logical and physical information on cartridges, MTC drives and robots. This is also where the [archive numbers](#) of a cartridge and its respective storing position are specified. The archive record is administered by [ROBAR-SV](#) at the [SCSI interface](#). It is administered by the ETERNUS CS HE software at the [ABBA interface](#).

archive system

One of the MTC archive systems supported by [ROBAR](#) when the archive systems do not need to be distinguished further

foreign cartridges

Cartridges that do not belong to the [archive system](#), but are nonetheless to be processed by [ROBAR](#).

ROBAR

The software product that controls [archive systems](#) from BS2000 systems. ROBAR consists of the parts [ROBAR-SV](#) and [ROBAR-CL](#).

ROBAR rule files (RRFs)

Files that define which messages the [archive system](#) is to react to and how ROBAR has to react to feedback information from the archive system.

ROBAR server

Server on which [ROBAR-SV](#) runs.

robar_abba

The component of [ROBAR-SV](#) for communicating with the [archive system](#), consisting of several cooperating background processes.

robar_mon

The monitor for [ROBAR-SV](#) communication with up to 110 BS2000 systems with the help of the software product CMX.

ROBAR-CL

Locally available component for linking a BS2000 system and the [ROBAR server](#) consisting of [ROBAR-CL-DCAM](#) and [ROBAR-CL-SDF](#).

ROBAR-CL-DCAM

DCAM application of [ROBAR-CL](#) with UCON authorization which forwards console message which are relevant to ROBAR to [ROBAR-SV](#) and receives requests from [ROBAR-SV](#) for a BS2000 system.

ROBAR-CL-SDF

BS2000 user program for entering organizational statements for MTCs in the archive system. Transfer to [ROBAR-SV](#) takes place using [ROBAR-CL](#).

ROBAR-freepool

Directory in which the [archive numbers](#) (VSNs) of the [SCRATCH cartridges](#) are stored.

ROBAR-SV

The central [ROBAR](#) part for communicating with the [archive system](#) and a maximum of 110 BS2000 systems. ROBAR-SV runs on the [ROBAR server](#).

ROBAR-SV instance

A ROBAR-SV instance operates an [archive system](#) or one of its partitions.

ROBAR-SV Manager

The ROBAR-SV Manager is a web application for operating the [ROBAR-SV instances](#) on the [ROBAR server](#).

SCRATCH cartridges

MTCs mounted in response to non-specific volume requests (VSN = *SCRAT, *UNKNO).

SCSI interface

Defines how the real archive systems Scalar i500, i2000 and i6000 are controlled by ROBAR.

VAMU

Interface for controlling the virtual robot in ETERNUS CS.

Related publications

You will find the manuals on the internet at <http://manuals.ts.fujitsu.com>. You can order printed versions of manuals which are displayed with the order number.

Manuals published by Fujitsu Ltd.

- [1] **openNet Server (BS2000)**
BCAM
User Guide
- [2] **BS2000 OSD/BC**
Introduction to System Administration
User Guide
- [3] **BS2000 OSD/BC**
Commands
User Guides
- [4] **BS2000 OSD/BC**
System Installation
User Guide
- [5] **BS2000 OSD/BC**
Utility Routines
User Guide
- [6] **IMON (BS2000)**
Installation Monitor
User Guide
- [7] **JV (BS2000)**
Job Variables
User Guide

- [8] **MAREN** (BS2000)
User Guide
- [9] **SDF** (BS2000)
SDF Dialog Interface
User Guide
- [10] **SECOS** (BS2000)
Security Control System - Access Control
User Guide
- [11] **ETERNUS CS**
Operation and Administration
User Guide
- [12] **CMX**
Communications Manager
Operation and Administration
User Guide
- [13] **CMX**
Communications Manager
CMX Programming Applications
Programmer's Guide
- [14] **FUJITSU Server BS2000 SE Series**
Operation and Administration
User Guide

Other documents

- [15] **Scalar Archive Systems**
Product descriptions on the Internet:
<http://www.quantum.com/de> --> products
- [16] **Linux**
Administration Guide

On the Internet:
<https://www.suse.com/documentation/sles11>
for SUSE Linux Enterprise Server 11 (64 bit)

Index

\$CONSOLE 191

A

ABBA interface 23, 351

account 106

action code 249, 268

action icon 110, 115

action type 250

action, executing 115

actions 351

 define for ROBAR 249

add-on pack ROBAR 102, 198

 special aspects 105

ADD-ROBAR-VOLUME (statement) 81

additional software vendor 311

administration PC 101

ARCHIVE 68, 84

archive

 initial stocking 29

 multiple 59

 order of the cartridges 29

archive number range

 displaying 132

archive numbers 28, 351

 adding to freepool 83

archive organization 28

archive record 29, 351

 delete entry 88

archive system 11, 19, 27, 351

 configuring 197

 error code 281, 307

 firewall 194

 MTC storing position 28

 terminating 308

 time loss 241

archive system command 171

 block command 182

 EJ, EJT, EJP, EJTP 66

 entering manually 128

 from the BS2000 system 314

 MO 176

 overview 174

asynchronous processing 277

authorization name

 dynamic 192

 static 191

automatic

 operation of ROBAR-SV 46

 PAUSE message answering 190

 storage space monitoring 54

automatic update 105, 108, 140, 143

autoreply 190

B

BACKUP_ROBAR_CONF 61

barcode label 28

 read 66

BS2000 console

 displaying a message 284

 displaying a message text 293

BS2000 console message 187, 255

 converting to mount statement 66, 68

 identification 249

BS2000 message

 defining the language 190

 outputting 316

BS2000 message file 187

BS2000 messages 315

 response to 288

BS2000 trace file 327

C

- cartridge request
 - non-specific 83
 - cartridge storage systems 28
 - cartridges
 - archive numbers 28
 - barcode label 28
 - error counter 318
 - export when MAREN is used 64
 - exporting 64, 87, 176
 - I/O area overflow 326
 - importing 62, 90
 - mount 176
 - central computer for MAREN 70
 - CentricStor, see ETERNUS CS
 - change the mode VSN/TSN 156
 - check_rrf (command) 152
 - cleaning cartridges 67
 - and multiprocessing 67
 - archive number 287
 - dismounting 66, 69
 - cleaning operation 67
 - cleaning statistics
 - compiling 168, 341
 - report list 346
 - client 11, 19
 - client/server architecture 11, 19
 - CMX 144
 - generation of names 238
 - remote system 238
 - COLLECT_DIAG_DATA 328
 - commands for MTC devices 35
 - communication
 - between ROBAR-CL and ROBAR-SV 24
 - between ROBAR-SV and the archive system 25
 - between system components 24
 - system components 25
 - configuration
 - graphical display 155
 - tabular display 157
 - variants 243
 - configuration file
 - checking 127
 - creating 212, 214
 - editing 126, 140
 - global 140, 141, 210
 - interface-specific 212
 - multiple archives 60
 - resetting 142
 - specifying 181
 - storage location name 73
 - updating existing 213
 - uploading 122
 - configuration parameters 209
 - connection
 - BS2000 system - ROBAR server 151, 193, 324
 - ROBAR server - archive system 194
 - ROBAR-CL - ROBAR-SV 24
 - ROBAR-SV - archive system 25
 - time monitoring 311
 - connection disruption 151, 324
 - console interface 20, 21
 - console message, see BS2000 console message
 - CREATE-ROBAR-FREEPOOL (statement) 83
 - and MAREN 84
 - creating
 - diagnostic data 137
 - statistics 138
- ### D
- DEFINES (menu) 152
 - DELETE-ROBAR-FREEPOOL (statement) 86
 - deleting trace files 52
 - DETACH identifier 278, 287, 289
 - device allocation
 - changing identifier 153
 - fixed 57
 - identifier 304
 - device configuration 232
 - device error counter 318
 - device management (NDM) 57
 - device reservation 24
 - device selection
 - in a mixed configuration 58

- device status byte
 - querying 277, 278
 - resetting 287
 - setting 289
- device type 30, 33
- device type specific file, see ROBAR rule file 247
- device, see MTC device
- diagnosis
 - ROBAR-SV 136
- diagnostic data 317
 - creating 137
- diagnostic documentation for BS2000 327
- diagnostic documentation for ROBAR-SV 137
 - creating using a menu 179
 - preparing manually 328
- dialog 111, 115
- dismounting cartridges 66
 - ETERNUS CS 69
- DISPLAY (menu) 154
- displaying
 - archive number range 132
 - certain settings 53
 - logging file 135
 - ROBAR actions 49
 - ROBAR status 49
- DMS 68
- downloading
 - logging file 135
- E**
- editing
 - ROBAR rule files 128
- editing the message keys 187
- editing the parameter file 187
- EJECT request, resume 280
- EJECT-POOL (command) 176
- EJECT-TOTAL-POOL (command) 176
- error
 - in ROBAR-SV Manager 117
- error counter 138, 177
- error counter limit 138
- error handling in ROBAR rule files 250
- error information 177
- error information for devices and volumes 138
- error logging information 53
- error recovery actions 317
- error statistics
 - compiling 168, 341
 - report list 349
- error_defines 323
 - contents 307
 - editing file 152
 - keywords 307
 - structure of the entries 309
- ETERNUS CS 11, 31, 68, 310
 - ROBAR rule file 310
 - storage location 71
- evaluation period 168
- EXIT (menu) 158
- EXPORT-ROBAR-VOLUME (statement) 87
- exporting cartridges 62, 64, 87, 93
- F**
- fabric 194
- fast mount 68
- FDDRL 66, 68
- fibre channel 23, 25
- file system full 54
- files for runtime control
 - see ROBAR rule files 48, 247
- filter 114
- firewall 194
- fixed device allocation 57
- foreign cartridges 82, 351
 - barcode label 81
 - configuring I/O area 81
 - exporting 88
 - matching VSNS 82
 - releasing 92, 286
 - supplying position 81
 - when MAREN is used 82
- freepool
 - adding archive numbers 83
 - creating 83
 - exporting cartridges 88
 - INPUT-FILE 84
 - organizational free tape check 84
 - releasing 86

- freepool
 - remove next cartridge free [288](#)
 - removing an cartridge [278](#)
 - scartch request [84](#)
 - task-specific [84](#), [86](#)
 - uniqueness check [161](#)
- FREEPOOL (menu) [159](#)
- freepool file
 - managing [279](#)
 - releasing [286](#)
- function
 - fast mount [68](#)
 - pre-restore [68](#)
- G**
- global configuration file [140](#)
- H**
- header area [110](#)
- home cartridge [82](#)
- Host Bus Adapter (HBA) [194](#)
- host statistics
 - compiling [168](#), [341](#)
 - report list [343](#)
- HSMS [12](#), [20](#)
- I**
- I/O blade [194](#)
- ignoring obsolete messages [183](#)
- IMPORT-ROBAR-VOLUME (statement) [62](#), [90](#)
- IMPORT/EXPORT statistics
 - compiling [168](#), [341](#)
 - report list [347](#)
- importing cartridges [62](#), [66](#), [90](#)
- information services ofROBAR-SV [49](#)
- INIT [20](#)
- INIT_RESTART_OPTION [46](#)
- Initial stocking of the archive [29](#)
- initializing tapes [70](#)
- input/output area overflow [326](#)
- input/output unit [26](#), [28](#), [62](#), [64](#)
- insert of a message [255](#)
- installation
 - Linux [198](#)
 - ROBAR-CL [185](#)
 - ROBAR-SV [198](#)
 - YaST [199](#)
- instance [41](#)
- INSTANCES (menu) [162](#)
- inventory statistics
 - compiling [168](#), [341](#)
 - report list [348](#)
- issuing a console command [278](#)
- J**
- job file [44](#)
- job variable [37](#)
- K**
- keywords
 - for error_defines [307](#)
 - for message_resp [275](#)
- L**
- LAN [193](#)
- LANG (environment variable) [204](#)
- language for BS2000 messages [190](#)
- language option [105](#), [110](#)
- LDAP users [209](#)
- LDCK (load check-) error [183](#)
- LIST (menu) [165](#)
- local name [144](#)
 - automatically generated [145](#)
- local users [209](#)
- logging file
 - displaying [135](#)
 - downloading [135](#)
 - removing [135](#)
- logging in
 - ROBAR-SV Manager [106](#)
- logging out
 - ROBAR-SV Manager [107](#)
- logical console [191](#)
- login window [106](#)

- M**
- main window 109
 - MANUAL (menu) 171
 - MAREN 12, 20, 34, 37, 71
 - and ROBAR 34, 71, 319
 - central computer 70
 - exporting cartridges 64
 - importing 62
 - in configuration file 214
 - initializing cartridges 70
 - installing ROBAR 185
 - using 244
 - MAX_CLEAN (parameter) 67
 - menu
 - DEFINES 152
 - DISPLAY 154
 - EXIT 158
 - FREEPOOL 159
 - INSTANCES 162
 - LIST 165
 - MANUAL 171
 - REPAIR 177
 - SAVE 179
 - START 180
 - STOP 182
 - message
 - adding new message 312
 - deleting 312
 - outputting 316
 - query help text 316
 - message code 249
 - BS2000 messages 316
 - console messages 187, 255
 - message file 187
 - message interpreter 21
 - message number 249
 - adding 312
 - message text
 - displaying on the console 293
 - insert 255
 - message_file 249
 - contents 260
 - editing file 152
 - structure of the entries 260
 - message_resp 250
 - contents 273
 - editing file 153
 - file structure 274
 - keywords 275
 - structure of the entries 274
 - message_xref 249
 - contents 268
 - specify actions 249
 - structure of the entries 268
 - mnemonic device names 232
 - monitoring
 - storage space 54
 - the ROBAR system 154
 - mount request
 - ETERNUS CS 68
 - example 252
 - executing 76
 - system cartridges 66
 - MSGMAKER 316
 - MTC archive system 19
 - MTC configuration display 155, 157
 - MTC device
 - allocating storage locations 73
 - cleaning 67
 - displaying 154
 - entering 294
 - error handling 58
 - error situation 325
 - managing 57
 - reservation 30, 33
 - searching for a VSN 283
 - type 30, 33
 - unloading 57, 175
 - multiple archives 59
 - multiple configuration 243
 - multiple storage locations 96
 - multiprocessing 48
 - cleaning the MTC device 67
 - presetting in configuration file 242
 - problems / solutions 241
 - robar_abba process 25
 - settings 240
 - multisystem environment 19

N

navigation 114
nbs2.trace 339
NDM 57, 71
network entries 187
NLS 315
non-specific cartridge request 83
 cartridge management 159
 response to 278
notification handler 282, 288, 292
NRDY 307
number of the archive 28, 60

O

obsolete messages, ignoring 183
online help 116

P

parameter area 111
parameters selecting 150
partner configuration 144
password 106
PAUSE automatic message answering 190
pre-restore 68
primary navigation 110
priorization 176
processing steps in ROBAR rule files 250
publish_rrf (command) 152

Q

querying the identity of the server 282
querying the robot status 174

R

range of VSNs 159
Readme file 15
RECOVER_DISK_FULL (script) 54
remote system (CMX) 238
remount situation 58
REMOVE-ROBAR-VOLUME (statement) 92
removing
 logging file 135
REPAIR (menu) 177
REPEAT (action operand) 308

resetting
 configuration file 142
resources 198
 for ROBAR-CL 185
restarting ROBAR-SV 46, 127
RESTORE_ROBAR_CONF 61
ROBAR 351
 controlling execution 48
 system components, communication 25
 termination with error 308
robar (menu program) 101
 calling 148
ROBAR actions, displaying 49
ROBAR administrator 39
ROBAR configuration
 backing up 61, 140
 restoring 61, 140
ROBAR editor 48
ROBAR error message 289
ROBAR freepool 84, 352
robar menu program 101, 148
 calling from ROBAR-SV Manager 130
 exit 151
 functional overview 151
 selecting parameters 150
 terminating 158
ROBAR operation, requirements 36
ROBAR operator 39
ROBAR rule file 21, 35, 48, 247, 352
 adding new message 312
 adjust 98
 contents 253
 description 255
 device types 247
 editing 128
 error handling 250
 modifying (example) 313
 overview (example) 252
 processing steps 250
 special characters 253
 virtual archiving system 310
ROBAR server 11, 19, 23, 25, 352
 firewall 194
 information 139

- ROBAR status, displaying 49
- ROBAR system 19
 - monitoring 154
 - mount/dismount requests 20
 - operating 36
 - organizational tasks 20
 - software components 19
 - starting in BS2000 38
 - terminating 182
- robar_abba 25, **352**
- ROBAR_BACKUP_DIR (parameter) 54
- robar_cmx **352**
- ROBAR_EDITOR (parameter) 159, 160
- robar_start (program) 43
- robar_stop (program) 45, 182
- ROBAR-CL 11, 19, 20, **352**
 - authorized user program 191
 - communication with ROBAR-SV 24
 - components 20
 - installing 185
 - message selection 249
 - operating 37
 - resources 185
- ROBAR-CL-DCAM 20, 37, **352**
 - dump after abnormal termination 190
 - monitoring connection setup 37
 - parameters 188
 - starting 37
 - terminating 38
 - trace file 331
- ROBAR-CL-SDF 20, 37, 79, **352**
 - prerequisite 79
 - starting 38
 - statements 80
 - terminating 38
- ROBAR-CMX 181
- ROBAR-SV 11, 19, 21, **352**
 - automatic operation 46
 - communication with ROBAR-CL 24
 - configuration 140
 - configuration parameters 48, 209
 - diagnostic data 136
 - directories 202
 - exporting cartridges 66
 - file system full 54
 - global configuration file 210
 - hardware 198
 - information and functions 22
 - information services 49
 - installation 198
 - interface-specific configuration file 212
 - messages 315
 - multisystem mode 21
 - operating 39
 - restarting 46, 127
 - role 39
 - selecting the host 198
 - server failure 324
 - starting 42
 - terminating 44
 - trace files 50
 - user (groups) 39
 - user information 139
- ROBAR-SV administrator 39
- ROBAR-SV instance 41, **352**
 - configuration file 126
 - creating 123
 - deleting 123
 - devices 133
 - diagnosis 136
 - information 122
 - job file 44
 - logging file 134
 - managing 162
 - messages 133
 - operating 125
 - starting 42, 180
 - status of the systems 131
 - stopping 44
 - wizard 42, 123
- ROBAR-SV Manager 101, **352**
 - calling robar menu program 130
 - controlling operation 118
 - interface 109
 - language 101
 - logging in 106
 - logging out 107
 - overview of tasks 118

ROBAR-SV operator 39
robar.trace 332
robot 288
robot failure 323
robot problems 241
roboter_cmds 250, 304
 contents 304
 editing file 153
 structure of the entries 304
role 39
routing code
 assigning 191, 192
 for SEND MESSAGE command 289
 for TYPE command 187, 259
RRF, see ROBAR rule file 48, 247
runtime control files
 see ROBAR rule file 48

S

sample configuration file 212, 213, 215, 227
SAN (Storage Area Network) 23, 194
SAVE (menu) 179
Scalar 11, 26
SCRATCH cartridges 83, 229
scratch cartridges 353
SCSI interface 23, 353
SDF standard statements 80
SE Manager 102, 104
SE server 104, 198, 211
 recommendations 193
 special aspects 102
 storage space 56
secondary navigation 110
SECOS in use 37, 71, 186
server 11, 19
session 107
session ID 107
Session management 107
Session-Timeout 105, 107, 140
SHOW-ROBAR-VOLUME (statement) 93
SoftBooks 316
software components 11, 19
sorting, table 115
standalone product ROBAR 104

standard freepool
 creating 42, 159
 deleting 160
 displaying 161
 editing 160
 managing 159
 printing 160
 uniqueness check 161
START (menu) 180
start file for ROBAR-CL-DCAM 188
start procedure for ROBAR 37
starting
 in BS2000 38
 ROBAR-SV instance 42, 180
startup parameter service 187
statistics
 compiling 168
 creating 138
 examples 341
 printing 169
statistics on manual inputs
 compiling 168, 341
 report list 345
status byte, see device and user status byte
status of the archive system 44
STOP (menu) 182
stopping
 ROBAR-SV instance 44
Storage Area Network (SAN) 23, 194
storage location 71
 allocating tape devices 73
 allocating tapes 72
 assigning a robot 88, 90, 92, 93
 defining in ROBAR 73
 ETERNUS CS 71
 install 72, 243
 managing 71, 72
storage space monitoring 54
 RECOVER_DISK_FULL 54
 SE server 56
storing position 28
subtask 279

summary statistics
 compiling 168, 341
 report list 342
 switch current robot arm logically off 292
 switching on trace information 50
 SYSMES.ROBAR-CL.ver 187
 SYSPAR.ROBAR-CL.ver.MESSAGES 187, 249
 SYSPAR.ROBAR-CL.ver.PROZPARAM 187,
 259
 SYSPAR.ROBAR-CL.ver.TEXT.D / E 190
 SYSPRC.ROBAR-CL.ver 60, 188
 SYSPRG.ROBAR-CL.ver.SDF 186
 SYSSDF.ROBAR-CL.ver 187
 system cartridges
 exporting 88
 system command 291
 system components 19
 system components, communication 24
 system syntax file 187

T

table, sorting 115
 tape monitor 66, 68
 TAPE-ADMINISTRATION (privilege) 37, 71, 186
 TCP/IP 23, 25, 193
 problems 329
 terminating a ROBAR-SV instance 182
 TNS (Transport Name Service) 238
 trace files
 deleting 43, 52, 55, 126, 165, 181
 evaluating 165, 166
 examples 332
 information 50
 managing 165
 nbs2.trace 339
 printing 169
 ROBAR-CL-DCAM 331
 robar.trace 332
 vbs2.trace 337
 trace_limit 50
 Transport Name Service (TNS) 238
 troubleshooting 317
 robot failure 323
 TYPE command 187, 259

U

uniform configuration 243
 uniqueness check 161
 UNLOAD 197
 unload operation MTC device 58
 UNLOAD-TAPE 171, 173, 175
 upgrading to new ROBAR version 244
 user
 LDAP 39
 local 39
 robar 39
 user group robaradm 39, 102, 104
 user group robarsv 39, 102, 104
 user interface
 for ROBAR-CL 79
 for ROBAR-SV 101
 user robar 102
 user status byte
 deleting 287
 querying 281
 setting 289, 290, 293
 user variables 110
 users 39
 LDAP 209
 local 209
 of ROBAR-SV 139

V

VAMU 31, 353
 vbs2.trace 338
 version change 244
 virtual archiving system 31, 310
 Virtual Tape Library 31
 virtual volume, releasing 69
 VM2000 19
 volume error counter 318
 volume reservation 24
 Volume Serial Number, see VSN
 volumes, allocating storage locations 72
 VSN
 guidelines 159, 218

W

wait time [241](#), [294](#)
WAN [193](#)
web application [101](#)
window types [109](#)
work area [110](#)

Y

YaST [198](#), [199](#)

Z

zoning [194](#)