

Model DMM6500 6½-Digit Multimeter With Scanning

Calibration and Adjustment Manual

DMM6500-905-01 Rev. A / July 2018



DMM6500-905-01A

Model DMM6500

6½-Digit Multimeter with Scanning Calibration and Adjustment Manual

© 2018, Keithley Instruments, LLC

Cleveland, Ohio, U.S.A.

All rights reserved.

Any unauthorized reproduction, photocopy, or use of the information herein, in whole or in part, without the prior written approval of Keithley Instruments, LLC, is strictly prohibited.

These are the original instructions in English.

TSP®, TSP-Link®, and TSP-Net® are trademarks of Keithley Instruments, LLC. All Keithley Instruments product names are trademarks or registered trademarks of Keithley Instruments, LLC. Other brand names are trademarks or registered trademarks of their respective holders.

The Lua 5.0 software and associated documentation files are copyright © 1994-2008, Tecgraf, PUC-Rio. Terms of license for the Lua software and associated documentation can be accessed at the Lua licensing site (<http://www.lua.org/license.html>).

Microsoft, Visual C++, Excel, and Windows are either registered trademarks or trademarks of Microsoft Corporation in the United States and/or other countries.

Document number: DMM6500-905-01 Rev. A / July 2018

The following safety precautions should be observed before using this product and any associated instrumentation. Although some instruments and accessories would normally be used with nonhazardous voltages, there are situations where hazardous conditions may be present.

This product is intended for use by personnel who recognize shock hazards and are familiar with the safety precautions required to avoid possible injury. Read and follow all installation, operation, and maintenance information carefully before using the product. Refer to the user documentation for complete product specifications.

If the product is used in a manner not specified, the protection provided by the product warranty may be impaired.

The types of product users are:

Responsible body is the individual or group responsible for the use and maintenance of equipment, for ensuring that the equipment is operated within its specifications and operating limits, and for ensuring that operators are adequately trained.

Operators use the product for its intended function. They must be trained in electrical safety procedures and proper use of the instrument. They must be protected from electric shock and contact with hazardous live circuits.

Maintenance personnel perform routine procedures on the product to keep it operating properly, for example, setting the line voltage or replacing consumable materials. Maintenance procedures are described in the user documentation. The procedures explicitly state if the operator may perform them. Otherwise, they should be performed only by service personnel.

Service personnel are trained to work on live circuits, perform safe installations, and repair products. Only properly trained service personnel may perform installation and service procedures.

Keithley products are designed for use with electrical signals that are measurement, control, and data I/O connections, with low transient overvoltages, and must not be directly connected to mains voltage or to voltage sources with high transient overvoltages. Measurement Category II (as referenced in IEC 60664) connections require protection for high transient overvoltages often associated with local AC mains connections. Certain Keithley measuring instruments may be connected to mains. These instruments will be marked as category II or higher.

Unless explicitly allowed in the specifications, operating manual, and instrument labels, do not connect any instrument to mains.

Exercise extreme caution when a shock hazard is present. Lethal voltage may be present on cable connector jacks or test fixtures. The American National Standards Institute (ANSI) states that a shock hazard exists when voltage levels greater than 30 V RMS, 42.4 V peak, or 60 VDC are present. A good safety practice is to expect that hazardous voltage is present in any unknown circuit before measuring.

Operators of this product must be protected from electric shock at all times. The responsible body must ensure that operators are prevented access and/or insulated from every connection point. In some cases, connections must be exposed to potential human contact. Product operators in these circumstances must be trained to protect themselves from the risk of electric shock. If the circuit is capable of operating at or above 1000 V, no conductive part of the circuit may be exposed.

Do not connect switching cards directly to unlimited power circuits. They are intended to be used with impedance-limited sources. NEVER connect switching cards directly to AC mains. When connecting sources to switching cards, install protective devices to limit fault current and voltage to the card.

Before operating an instrument, ensure that the line cord is connected to a properly-grounded power receptacle. Inspect the connecting cables, test leads, and jumpers for possible wear, cracks, or breaks before each use.

When installing equipment where access to the main power cord is restricted, such as rack mounting, a separate main input power disconnect device must be provided in close proximity to the equipment and within easy reach of the operator.

For maximum safety, do not touch the product, test cables, or any other instruments while power is applied to the circuit under test. ALWAYS remove power from the entire test system and discharge any capacitors before: connecting or disconnecting cables or jumpers, installing or removing switching cards, or making internal changes, such as installing or removing jumpers.

Do not touch any object that could provide a current path to the common side of the circuit under test or power line (earth) ground. Always make measurements with dry hands while standing on a dry, insulated surface capable of withstanding the voltage being measured.

For safety, instruments and accessories must be used in accordance with the operating instructions. If the instruments or accessories are used in a manner not specified in the operating instructions, the protection provided by the equipment may be impaired.

Do not exceed the maximum signal levels of the instruments and accessories. Maximum signal levels are defined in the specifications and operating information and shown on the instrument panels, test fixture panels, and switching cards.

When fuses are used in a product, replace with the same type and rating for continued protection against fire hazard.

Chassis connections must only be used as shield connections for measuring circuits, NOT as protective earth (safety ground) connections.

If you are using a test fixture, keep the lid closed while power is applied to the device under test. Safe operation requires the use of a lid interlock.

If a  screw is present, connect it to protective earth (safety ground) using the wire recommended in the user documentation.

The  symbol on an instrument means caution, risk of hazard. The user must refer to the operating instructions located in the user documentation in all cases where the symbol is marked on the instrument.

The  symbol on an instrument means warning, risk of electric shock. Use standard safety precautions to avoid personal contact with these voltages.

The  symbol on an instrument shows that the surface may be hot. Avoid personal contact to prevent burns.

The  symbol indicates a connection terminal to the equipment frame.

If this  symbol is on a product, it indicates that mercury is present in the display lamp. Please note that the lamp must be properly disposed of according to federal, state, and local laws.

The **WARNING** heading in the user documentation explains hazards that might result in personal injury or death. Always read the associated information very carefully before performing the indicated procedure.

The **CAUTION** heading in the user documentation explains hazards that could damage the instrument. Such damage may invalidate the warranty.

The **CAUTION** heading with the  symbol in the user documentation explains hazards that could result in moderate or minor injury or damage the instrument. Always read the associated information very carefully before performing the indicated procedure. Damage to the instrument may invalidate the warranty.

Instrumentation and accessories shall not be connected to humans.

Before performing any maintenance, disconnect the line cord and all test cables.

To maintain protection from electric shock and fire, replacement components in mains circuits — including the power transformer, test leads, and input jacks — must be purchased from Keithley. Standard fuses with applicable national safety approvals may be used if the rating and type are the same. The detachable mains power cord provided with the instrument may only be replaced with a similarly rated power cord. Other components that are not safety-related may be purchased from other suppliers as long as they are equivalent to the original component (note that selected parts should be purchased only through Keithley to maintain accuracy and functionality of the product). If you are unsure about the applicability of a replacement component, call a Keithley office for information.

Unless otherwise noted in product-specific literature, Keithley instruments are designed to operate indoors only, in the following environment: Altitude at or below 2,000 m (6,562 ft); temperature 0 °C to 50 °C (32 °F to 122 °F); and pollution degree 1 or 2.

To clean an instrument, use a cloth dampened with deionized water or mild, water-based cleaner. Clean the exterior of the instrument only. Do not apply cleaner directly to the instrument or allow liquids to enter or spill on the instrument. Products that consist of a circuit board with no case or chassis (e.g., a data acquisition board for installation into a computer) should never require cleaning if handled according to instructions. If the board becomes contaminated and operation is affected, the board should be returned to the factory for proper cleaning/servicing.

Safety precaution revision as of June 2017.

Table of contents

Introduction	1-1
Welcome	1-1
Introduction to this manual	1-1
Extended warranty	1-1
Contact information	1-2
Performance verification	2-1
Introduction	2-1
Verification test requirements	2-2
Environmental conditions	2-2
Warmup period.....	2-2
Line power.....	2-2
Recommended test equipment	2-3
Calibration verification limits	2-3
Example reading limit calculation	2-4
Calculating resistance reading limits	2-4
Performing the verification test procedures	2-4
Test summary	2-5
Test considerations	2-5
Front-panel calibration verification	2-6
DC voltage verification	2-6
AC voltage verification	2-8
Digitize voltage verification.....	2-12
Frequency verification	2-14
Simulated thermocouple Type J temperature verification	2-15
Simulated RTD temperature verification	2-17
Resistance verification	2-20
DC current verification.....	2-24
Digitize current verification	2-28
AC current verification.....	2-30
Capacitance verification	2-33
Verifying zero values using a 4-wire short.....	2-35
Rear-panel verification	2-37
DC current 10 A range verification	2-37
Digitize current 10 A range verification.....	2-39
AC current 10 A verification.....	2-40
Adjustment	3-1
Introduction	3-1
Environmental conditions	3-1
Temperature and relative humidity	3-2
Line power.....	3-2
Warmup period.....	3-2
Adjustment overview	3-2
Recommended test equipment	3-3

General adjustment considerations	3-3
Initial instrument setup	3-4
Select the correct terminals.....	3-4
Select the TSP command set.....	3-4
Verify instrument date and time.....	3-5
Set up remote connections	3-5
Unlock calibration.....	3-5
Disable temperature correction	3-6
Remote calibration adjustment procedures	3-6
Disable temperature correction	3-6
Front-terminal adjustment with a 4-wire short	3-6
Rear-terminal adjustment with a 4-wire short.....	3-9
Front-terminal adjustment with open circuit inputs	3-10
Rear-terminal adjustment with open circuit inputs.....	3-11
Resistance adjustment.....	3-12
DC voltage adjustment.....	3-14
DC current adjustment	3-16
DC current 10 A range adjustment.....	3-18
AC voltage adjustment	3-20
AC current adjustment	3-22
AC current 10 A range adjustment	3-23
Frequency adjustment.....	3-24
Complete list of calibration commands.....	3-26
Enable temperature correction.....	3-37
Save calibration and set the adjustment dates	3-38
Setting time, adjustment, and verification dates	3-38
Adjustment command timing and error checking.....	3-39
Handling events	3-39
TSP command reference.....	4-1
TSP commands.....	4-1
Introduction	4-1
cal.adjust.count	4-1
cal.adjust.date	4-2
cal.adjust.step.setup()	4-3
cal.adjust.step.execute()	4-4
cal.lock().....	4-5
cal.password	4-6
cal.save().....	4-7
cal.unlock().....	4-8
cal.verify.date	4-9

Introduction

In this section:

Welcome	1-1
Introduction to this manual	1-1
Extended warranty	1-1
Contact information	1-2

Welcome

The DMM6500 is a 6½ digit graphical sampling multimeter that expands standard DMM functions with high-speed digitizing and large graphical color touchscreen display.

This manual provides information on completing verification and adjustment procedures for your DMM6500.

Introduction to this manual

This manual provides instructions to help you calibrate and adjust your Keithley Instruments Model DMM6500. In this manual, the term "calibration" refers to the process of verifying that the accuracy of the instrument is within its one-year accuracy specifications. The term "adjustment" refers to the process of changing the calibration constants so that the accuracy of the instrument is within its one-year accuracy specifications.

This manual presents calibration information, adjustment information, and command descriptions for the calibration and adjustment commands.

NOTE

For additional command descriptions, refer to the *DMM6500 Reference Manual* (part number DMM7510-901-01). This manual is on the Product Information CD-ROM that came with your instrument. It is also available on the [Product Support web page](https://www.tek.com/product-support) (<https://www.tek.com/product-support>).

Extended warranty

Additional years of warranty coverage are available on many products. These valuable contracts protect you from unbudgeted service expenses and provide additional years of protection at a fraction of the price of a repair. Extended warranties are available on new and existing products. Contact your local Keithley Instruments office, sales partner, or distributor for details.

Contact information

If you have any questions after you review the information in this documentation, please contact your local Keithley Instruments office, sales partner, or distributor. You can also call the corporate headquarters of Keithley Instruments (toll-free inside the U.S. and Canada only) at 1-800-935-5595, or from outside the U.S. at +1-440-248-0400. For worldwide contact numbers, visit the [Keithley Instruments website](http://www.tek.com/keithley) (<http://www.tek.com/keithley>).

Performance verification

In this section:

Introduction	2-1
Verification test requirements	2-2
Calibration verification limits	2-3
Performing the verification test procedures	2-4
Front-panel calibration verification	2-6
Rear-panel verification	2-37

Introduction

Use the procedures in this section to verify that DMM6500 accuracy is within the limits stated in the instrument's one-year accuracy specifications. Specifications and characteristics are subject to change without notice; refer to the [Product Support web page \(https://www.tek.com/product-support\)](https://www.tek.com/product-support) for the most recent specifications.

You can use these verifications procedures to:

- Make sure that the instrument was not damaged during shipment.
- Verify that the instrument meets factory specifications.
- Determine if adjustment is required.
- Verify that adjustment was done properly.

WARNING

The information in this section is intended for qualified service personnel only. Do not attempt these procedures unless you are qualified to do so. Some of these procedures may expose you to hazardous voltages, which could cause personal injury or death if contacted. Use appropriate safety precautions when working with hazardous voltages.

NOTE

If the instrument is still under warranty and its performance is outside specified limits, please contact your local Keithley Instruments office, sales partner, or distributor. You can also call the corporate headquarters of Keithley Instruments (toll-free inside the U.S. and Canada only) at 1-800-935-5595, or from outside the U.S. at +1-440-248-0400. For worldwide contact numbers, visit the [Keithley Instruments website \(http://www.tek.com/keithley\)](http://www.tek.com/keithley).

Verification test requirements

Be sure that you perform these verification tests:

- Under the proper environmental conditions.
- After the specified warmup period.
- Using the correct line voltage.
- Using the proper test equipment.
- Using the specified output signal and reading limits.

Environmental conditions

Conduct the calibration verification procedures in a test environment with:

- An ambient temperature of 18 °C to 28 °C.
- A relative humidity of less than or equal to 80 percent, unless otherwise noted.
- No direct airflow on the input terminals.

Warmup period

Allow the DMM6500 to warm up for at least 30 minutes before conducting the calibration verification procedures.

If the instrument has been subjected to temperature extremes (more than 5 °C above or below T_{cal}), allow additional time for the internal temperature of the instrument to stabilize. Typically, allow an additional 30 minutes to stabilize an instrument that is 10 °C outside the specified temperature range.

Also, allow the test equipment to warm up for the time recommended by the manufacturer.

Line power

The DMM6500 requires a line voltage of 100 V to 240 V and a line frequency of 50 Hz, 60 Hz, or 400 Hz. Calibration verification tests should be performed within this range.

NOTE

The instrument automatically senses the line frequency at power up.

Recommended test equipment

The following table summarizes the recommended calibration verification equipment. You can use alternate equipment if that equipment has specifications that meet or exceed those listed in the table below. Test equipment uncertainty adds to the uncertainty of each measurement. Generally, test equipment uncertainty should be at least four times more accurate than corresponding DMM6500 specifications.

NOTE

In this manual, the Model 8610 shorting plug is shown in the figures. However, you can use either the Model 8610 or Model 8620.

Manufacturer	Model	Description	Used for	Uncertainty
Fluke	5720A or 5730A	High-Performance Multifunction Calibrator	DCV, ACV, ACI, and resistance	See following note.
Fluke	5725A	Amplifier	DCI and ACI	See following note.
Fluke	8508A	8.5-Digit Reference Multimeter	DCV and resistance	See following note.
Keithley Instruments	3390	Function/Arbitrary Waveform Generator	Frequency	See following note.
IET Labs, Inc.	1423-A	Precision Decade Capacitor	Capacitance, 1 nF to 1 μ F	See following note.
IET Labs, Inc.	HACS-Z-A-2E-1uF	Series HACS-Z High Accuracy Decade Capacitance Box	Capacitance, 1 μ F to 100 μ F	See following note.
Keithley Instruments	8610 or 8620	4-Wire DMM Shorting Plug	DCV, digitize DCV, and resistance	See following note.

NOTE

Refer to the manufacturer's specifications to calculate the uncertainty, which varies for each function and range test point.

Calibration verification limits

The calibration verification limits stated in this section have been calculated using only the DMM6500 one-year accuracy specifications and ambient temperature ± 5 °C from T_{CAL} (the temperature at which the instrument was calibrated). They do not include test equipment uncertainty. If a particular measurement falls outside the allowable range, recalculate new limits based on both the DMM6500 specifications and corresponding test equipment specifications.

Specifications and characteristics are subject to change without notice; please refer to the [Keithley Instruments website](https://www.tek.com/keithley) (<https://www.tek.com/keithley>) for the most recent specifications.

Example reading limit calculation

Assume you are testing the 10 VDC range using a 10 V input value. Using the DMM6500 one-year accuracy specification for 10 VDC of \pm (25 ppm of reading + 5 ppm of range), the calculated limits are:

$$\text{Reading limits} = 10 \text{ V} \pm [(10 \text{ V} \times 25 \text{ ppm}) + (10 \text{ V} \times 5 \text{ ppm})]$$

$$\text{Reading limits} = 10 \text{ V} \pm (0.00025 + 0.00005) \text{ V}$$

$$\text{Reading limits} = 10 \text{ V} \pm 0.00030 \text{ V}$$

$$\text{Reading limits} = 9.99970 \text{ V to } 10.00030 \text{ V}$$

Calculating resistance reading limits

Resistance reading limits must be recalculated based on the actual calibration resistance values supplied by the equipment manufacturer. Calculations are performed in the same manner as shown in the preceding example. Use the actual calibration resistance values instead of the nominal values in the example when performing your calculations.

For example, assume that you are testing the 10 k Ω range using an actual 10.03 k Ω calibration resistance value. Using DMM6500 one-year 10 k Ω range accuracy of \pm (75 ppm of reading + 6 ppm of range), the calculated reading limits are:

$$\text{Reading limits} = 10.03 \text{ k}\Omega \pm [(10.03 \text{ k}\Omega \times 75 \text{ ppm}) + (10 \text{ k}\Omega \times 6 \text{ ppm})]$$

$$\text{Reading limits} = 10.03 \text{ k}\Omega \pm [(0.7523) + (0.06)] \Omega$$

$$\text{Reading limits} = 10.03 \text{ k}\Omega \pm 0.8123 \Omega$$

$$\text{Reading limits} = 10.029188 \text{ k}\Omega \text{ to } 10.030812 \text{ k}\Omega$$

Performing the verification test procedures

The following topics provide a summary of calibration verification test procedures and items to consider before performing any calibration verification test.

Test summary

Front-panel tests:

- [DC voltage verification](#) (on page 2-6)
- [AC voltage verification](#) (on page 2-8)
- [Digitize voltage verification](#) (on page 2-12)
- [Frequency verification](#) (on page 2-14)
- [Simulated thermocouple type J temperature verification](#) (on page 2-15)
- [Simulated RTD temperature verification](#) (on page 2-17)
- [Resistance verification](#) (on page 2-20)
- [DC current verification](#) (on page 2-24)
- [Digitize current verification](#) (on page 2-28)
- [AC current verification](#) (on page 2-30)
- [Capacitance verification](#) (on page 2-33)
- [Verifying zero values using a 4-wire short](#) (on page 2-35)

Rear-panel tests:

- [DC current 10 A range verification](#) (on page 2-37)
- [Digitize current 10 A range verification](#) (on page 2-39)
- [AC current 10 A verification](#) (on page 2-40)

Test considerations

When performing the calibration verification procedures:

- Be sure to restore factory front-panel defaults. From the front panel, select the **MENU** key, select **Info/Manage**, and select **System Reset**.
- Make sure that the test equipment is warmed up for the time recommended by the manufacturer and is connected to the DMM6500 input/output terminals.
- Make sure that the correct DMM6500 terminals are selected with the TERMINALS FRONT/REAR switch.
- Make sure the test equipment is set up for the proper function and range.
- Do not connect test equipment to the DMM6500 through a scanner, multiplexer, or other switching equipment.

Figure 1: VARIABLE - WARNING

WARNING

The front and rear terminals of the instrument are rated for connection to circuits rated Measurement Category II up to 300 V, as described in International Electrotechnical Commission (IEC) Standard IEC 60664. This range must not be exceeded. Do not connect the instrument terminals to CAT III or CAT IV circuits. Connection of the instrument terminals to circuits higher than CAT II can cause damage to the equipment and severe personal injury.

Front-panel calibration verification

The following topics describe verification procedures that are done with connections attached to the terminals on the DMM6500 front panel.

DC voltage verification

⚠ WARNING

The maximum input voltage between INPUT HI and INPUT LO is 1000 V DC and 750 V AC. Exceeding this value may create a shock hazard.

The maximum common-mode voltage (the voltage between INPUT LO and chassis ground) is 500 V_{PEAK}. Exceeding this value may cause a breakdown in insulation that can create a shock hazard.

Verify DC voltage accuracy for the 100 mV to 1000 V ranges

To verify 100 mV to 1000 VDC voltage accuracies, you will:

- Apply accurate DC voltages from the calibrator to the DMM6500 front-panel terminals.
- Verify that the displayed readings are within specified limits.

Use the values in the tables following the steps below to verify the performance of the DMM6500. Actual values depend on the published specifications (see [Example reading limit calculation](#) (on page 2-4)).

NOTE

Use shielded low-thermal connections when testing the 100 mV and 1 V ranges to avoid errors caused by noise or thermal effects. Connect the shield to the output LO terminal of the calibrator.

To verify DC voltage accuracy:

1. Use a low-thermal cable to connect the DMM6500 HI and LO INPUT terminals to the calibrator HI and LO terminals as shown in the following figure.

Figure 2: DC voltage 100 mV to 1000 V ranges verification connections

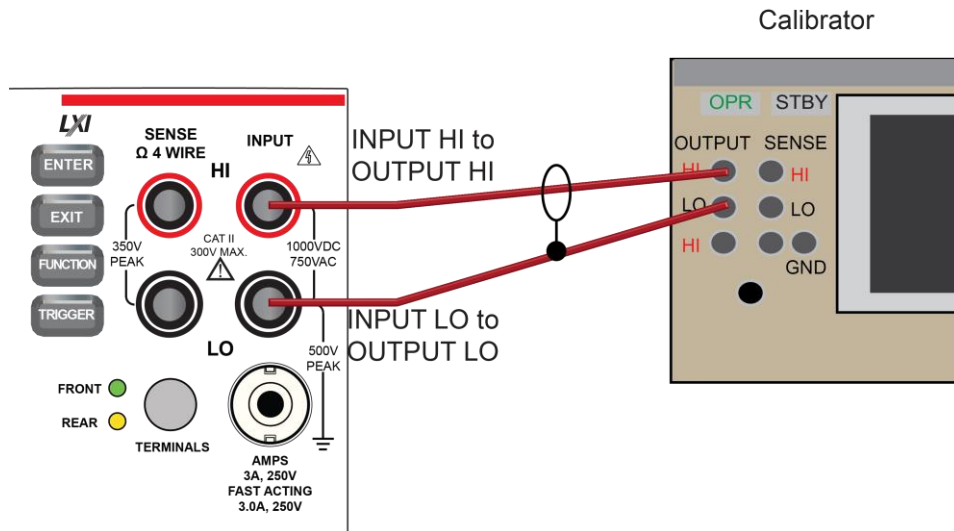

2. On the DMM6500, press the **FUNCTION** key and select **DC voltage**.
3. On the Home screen, select the button next to Range and select **100 mV**.
4. Press the **MENU** key.
5. Under Measure, select **Settings**.
6. Set Input Impedance to **Auto**.
7. Set the calibrator output to **0 V**.
8. Set the calibrator to **OPERATE**.
9. Allow 5 minutes of settling time.
10. Press the **MENU** key.
11. Select **Calculations**.
12. Select **Rel Acquire**.
13. Source positive and negative full-scale and half-scale voltages and allow for proper settling.
14. Select each range on the DMM6500, allow for proper settling, and verify the ranges according to the following tables.

Verify the DC voltage 100 mV range

Description	Verification point	Lower limit	Upper limit
Perform relative offset	0	n/a	n/a
Full scale (+)	1.000000E-01	9.999350E-02	1.000065E-01
Half scale (+)	5.00000E-02	4.99950E-02	5.00050E-02
Half scale (-)	-5.00000E-02	-5.00050E-02	-4.99950E-02
Full scale (-)	-1.000000E-01	-1.000065E-01	-9.99935E-02

Verify the DC voltage 1 V range

Description	Verification point	Lower limit	Upper limit
Full scale (+)	1.000000E+00	9.99969E-01	1.000031E+00
Half scale (+)	5.00000E-01	4.99979E-01	5.00021E-01
Half scale (-)	-5.00000E-01	-5.00021E-01	-4.99979E-01
Full scale (-)	-1.000000E+00	-1.000031E+00	-9.99969E-01

Verify the DC voltage 10 V range

Description	Verification point	Lower limit	Upper limit
Full scale (+)	1.000000E+01	9.99970E+00	1.000030E+01
Half scale (+)	5.00000E+00	4.99985E+00	5.00018E+00
Half scale (-)	-5.00000E+00	-5.00018E+00	-4.99985E+00
Full scale (-)	-1.000000E+01	-1.000030E+01	-9.99970E+00

Verify the DC voltage 100 V range**⚠ WARNING**

The information in this section is intended for qualified service personnel only. Do not attempt these procedures unless you are qualified to do so. Some of these procedures may expose you to hazardous voltages, which could cause personal injury or death if contacted. Use appropriate safety precautions when working with hazardous voltages.

Description	Verification point	Lower limit	Upper limit
Full scale (+)	1.000000E+02	9.999540E+01	1.0000460E+02
Half scale (+)	5.000000E+01	4.999685E+01	5.000315E+01
Half scale (-)	-5.0000000E+01	-5.000315E+01	-4.999685E+01
Full scale (-)	-1.000000E+02	-1.0000460E+02	-9.999540E+01

Verify the DC voltage 1000 V range

Description	Verification point	Lower limit	Upper limit
Full scale (+)	1.000000E+03	9.99931E+02	1.000069E+03
Half scale (+)	5.00000+02	4.99974E+02	5.00026E+02
Half scale (-)	-5.00000+02	-5.00026E+02	-4.99974E+02
Full scale (-)	-1.000000E+03	-1.000069E+03	-9.99931E+02

AC voltage verification**To verify AC voltage accuracy:**

- For the 100 mV to 100 V ranges, apply accurate voltages from the calibrator to the DMM6500 front-panel terminals.
- For the 750 V range, connect the Fluke 5725A Amplifier to the calibrator. Apply accurate voltages from the calibrator terminals to the terminals on the front panel of the DMM6500.
- Verify that the displayed readings are within specified limits.

Use the values in the tables following the steps below to verify the performance of the DMM6500. Actual values depend on the published specifications (see [Example reading limit calculation](#) (on page 2-4)).

⚠ WARNING

The maximum input voltage between INPUT HI and INPUT LO is 750 V DC. Exceeding this value may create a shock hazard.

The maximum common-mode voltage (the voltage between INPUT LO and chassis ground) is 500 V_{PEAK}. Exceeding this value may cause a breakdown in insulation that can create a shock hazard.

Verify AC voltage accuracy for the 100 mV to 100 V ranges

NOTE

Use shielded, low-capacitance cabling. For the 100 mV to 100 V ranges, avoid loading that exceeds 1000 pF.

Excessive capacitance may result in additional load regulation uncertainties and could cause the calibrator output to open (go into standby).

To verify AC voltage accuracy:

1. Connect the DMM6500 HI and LO INPUT connectors to the calibrator as shown in the following figure.

Figure 3: Connections for AC voltage verification 100 mV to 100 V ranges

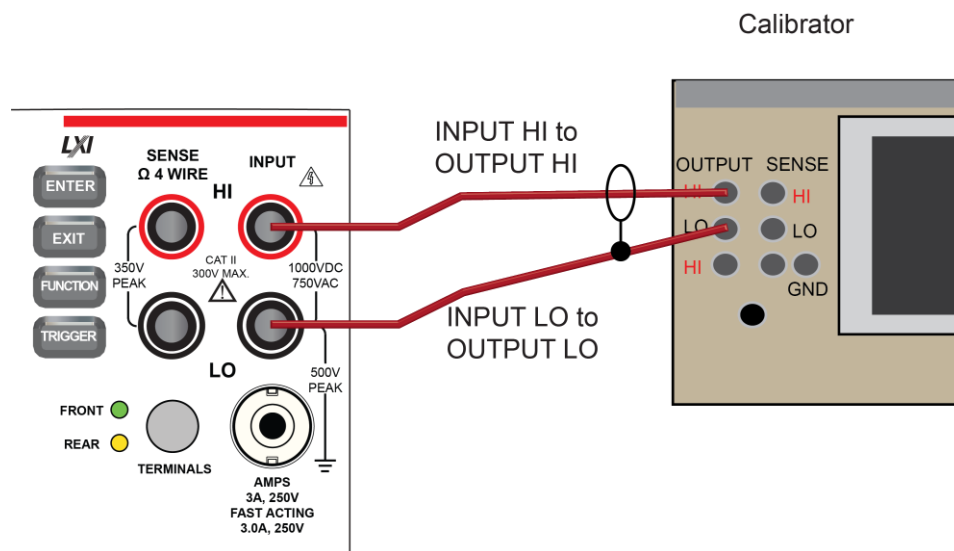

2. On the DMM6500, press the **FUNCTION** key and select **AC voltage**.
3. On the Home screen, select the button next to Range and select **100 mV**.
4. Press the **MENU** key.
5. Under Measure, select **Settings**.
6. Make sure that detector bandwidth is set to **30 Hz**.

NOTE

AC voltage is specified for the detector bandwidth setting of 3 Hz. Three Hz measures accurately for input signals from 3 Hz to 300 kHz, with reading rates ≈ 0.5 readings/s. To improve verification throughput to ≈ 3.3 readings/s, set detector bandwidth to 30 Hz for frequencies of 30 Hz to 300 kHz. To verify frequencies 1 kHz and higher, set the detector bandwidth to 300 Hz for faster ≈ 55 readings/s throughput.

7. Source AC voltages for each of the frequencies listed in the [Verify the AC voltage 100 mV range](#) (on page 2-10) table.
8. Repeat these steps for each range and frequency listed in the tables below. For each voltage setting, be sure that the reading is within low and high limits.

Verify the AC voltage 100 mV range

Input	Frequency	Lower limit	Upper limit
0.1	3.0E+01	9.9910E-02	1.00090E-01
0.1	1.0E+03	9.9910E-02	1.00090E-01
0.1	5.0E+04	9.9830E-02	1.00170E-01
0.1	1.0E+05	9.9320E-02	1.00680E-01

Verify the AC voltage 1 V range

Input	Frequency	Lower limit	Upper limit
1	3.0E+01	9.991000E-01	1.000900E+00
1	1.0E+03	9.991000E-01	1.000900E+00
1	5.0E+04	9.983000E-01	1.001700E+00
1	1.0E+05	9.93200E-01	1.006800E+00

Verify the AC voltage 10 V range

Input	Frequency	Lower limit	Upper limit
10	3.0E+01	9.991000E+00	1.000900E+01
10	1.0E+03	9.991000E+00	1.000900E+01
10	5.0E+04	9.983000E+00	1.001700E+01
10	1.0E+05	9.932000E+00	1.006800E+01

Verify the AC voltage 100 V range

Input	Frequency	Lower limit	Upper limit
100	3.0E+01	9.991000E+01	1.000900E+02
100	1.0E+03	9.991000E+01	1.000900E+02
100	5.0E+04	9.983000E+01	1.001700E+02
100	1.0E+05	9.932000E+01	1.006800E+02

Verify AC voltage accuracy for the 750 V range**NOTE**

Use shielded low capacitance cabling. For the 750 V range, avoid cable capacitances of >150 pF.

Excessive capacitance may result in additional load regulation uncertainties and could cause the calibrator output to open (go into standby).

To verify AC voltage accuracy for the 750 V range:

1. Put the calibrator in Standby.
2. Connect the DMM6500 HI and LO INPUT connectors to the calibrator as shown in the following figure.
3. For 750 V at 50 kHz and 100 kHz outputs, connect the calibrator to the Fluke 5725A amplifier.

Figure 4: Connections for AC voltage accuracy verification 750 V range

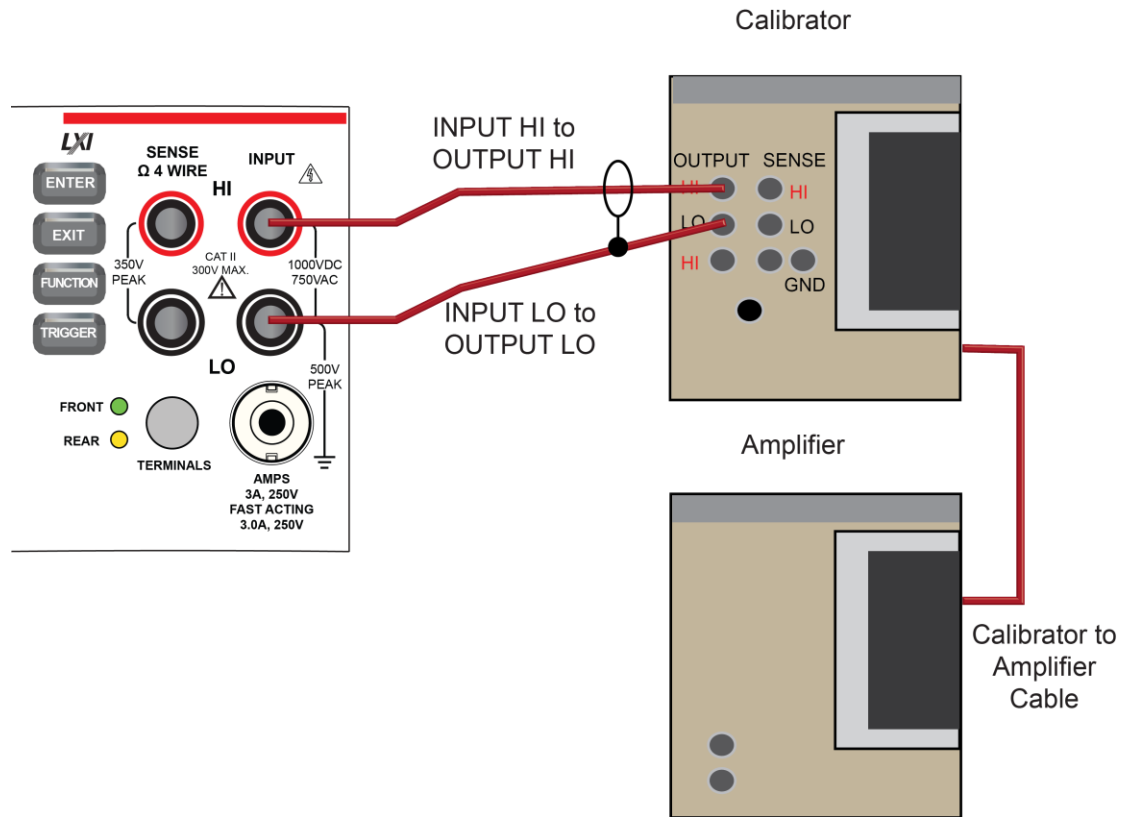

4. On the DMM6500, press the **FUNCTION** key and select **AC voltage**.
5. On the Home screen, select the button next to Range and select **750 V**.
6. Press the **MENU** key.
7. Under Measure, select **Settings**.
8. Ensure that detector bandwidth is set to **30 Hz**.

NOTE

AC voltage is specified for the detector bandwidth setting of 3 Hz. Three Hz measures accurately for input signals from 3 Hz to 300 kHz, with reading rates ≈ 0.5 readings/s. To improve verification throughput to ≈ 3.3 readings/s, set detector bandwidth to 30 Hz for frequencies of 30 Hz to 300 kHz. To verify frequencies 1 kHz and higher, set the detector bandwidth to 300 Hz for faster ≈ 55 readings/s throughput.

9. Set the calibrator to **OPERATE**.
10. Source AC voltages for each of the frequencies listed in the "Verify the AC voltage 750 V range" table, below. Be sure that the readings are within low and high limits.

Verify the AC voltage 750 V range

Input	Frequency (Hz)	Lower limit	Upper limit
740	5.0E+01	7.392570E+02	7.407430E+02
740	1.0E+03	7.392570E+02	7.407430E+02
740	5.0E+04	7.387370E+02	7.412630E+02
740	1.0E+05	7.349600E+02	7.450400E+02

Digitize voltage verification

To verify digitize DC voltage accuracy, you will:

- Apply accurate voltages from the calibrator to the terminals on the front panel of the DMM6500.
- Verify that the displayed readings are within specified limits.

Use the values in the tables following the steps below to verify the performance of the DMM6500. Actual values depend on the published specifications (see [Example reading limit calculation](#) (on page 2-4)).

⚠ WARNING

The maximum input voltage between INPUT HI and INPUT LO is 1000 V DC and 750 V AC. Exceeding this value may create a shock hazard.

The maximum common-mode voltage (the voltage between INPUT LO and chassis ground) is 500 V_{PEAK}. Exceeding this value may cause a breakdown in insulation that can create a shock hazard.

Verify the digitize voltage 100 mV to 1000 V ranges

NOTE

Use shielded low-thermal connections when testing the 100 mV and 1 V ranges to avoid errors caused by noise or thermal effects. Connect the shield to the output LO terminal of the calibrator.

To verify digitize voltage accuracy:

1. Connect the DMM6500 HI and LO INPUT connectors to the calibrator as shown in the following figure.

Figure 5: Connections for digitize voltage verification 100 mV to 1000 V ranges

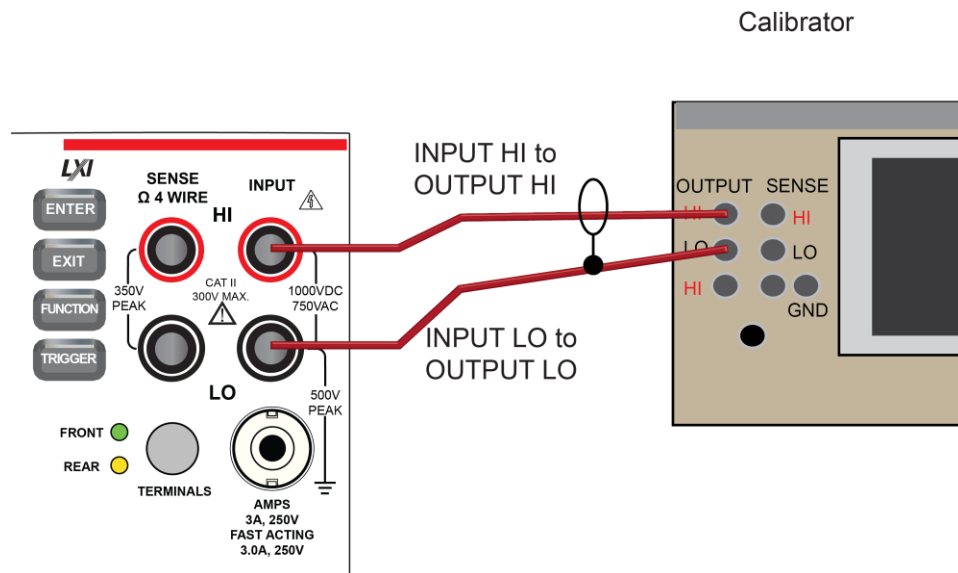

2. On the DMM6500, press the **FUNCTION** key, select the **Digitize Functions** tab, and select **Digitize Voltage**.
3. On the Home screen, select the button next to Range and select **100 mV**.
4. Press the **MENU** key.
5. Under Measure, select **Settings**.
6. Set the Sample Rate to **1000**.
7. Set the Aperture to **Auto**.
8. Set the Count to **100**.
9. Set the calibrator output to 0.00000 mV DC and allow the reading to settle.
10. Press the **MENU** key.
11. Under Measure, select **Calculations**.
12. Select **Rel Acquire**.
13. Source positive and negative full-scale and half-scale voltages, as listed in the following table. Verify the 1 V to 100 V range settings listed in the tables below. For each voltage setting, verify that the STATISTICS swipe screen reading for Average is within low and high limits.

NOTE

The Fluke 5720A or 5730A calibrator 1000 V range 0.0 V setting is not verified.

Verify the digitize voltage 100 mV range

Description	Input	Lower limit	Upper limit
Perform relative offset	0	n/a	n/a
Full scale (+)	0.1	9.9940E-02	1.00060E-01
Half scale (+)	0.05	4.9950E-02	5.0050E-02
Half scale (-)	-0.05	-5.0050E-02	-4.9950E-02
Full scale (-)	-0.1	-1.00060E-01	-9.9940E-02

Verify the digitize voltage 1 V range

Description	Input	Lower limit	Upper limit
Verify zero	0	-1E-04	1E-04
Full scale (+)	1	9.9960E-01	1.00040E+00
Half scale (+)	0.5	4.9975E-01	5.0025E-01
Half scale (-)	-0.5	-5.0025E-01	-4.9975E-01
Full scale (-)	-1	-1.00040E+00	-9.9960E-01

Verify the digitize voltage 10 V range

Description	Input	Lower limit	Upper limit
Verify zero	0	-1E-03	1E-03
Full scale (+)	10	9.9960E+00	1.00040E+01
Half scale (+)	5	4.9975E+00	5.0025E+00
Half scale (-)	-5	-5.0025E+00	-4.9975E+00
Full scale (-)	-10	-1.00040E+01	-9.996E+00

Verify the digitize voltage 100 V range

Description	Input	Lower limit	Upper limit
Verify zero	0	-1E-02	1E+02
Full scale (+)	100	9.9960E+01	1.00040E+02
Half scale (+)	50	4.9975E+01	5.0025E+01
Half scale (-)	-50	-5.0025E+01	-4.9975E+01
Full scale (-)	-100	-1.00040E+02	-9.996E+01

Verify the digitize voltage 1000 V range

Description	Input	Lower limit	Upper limit
Full scale (+)	1000	9.9960E+02	1.00040E+03
Half scale (+)	500	4.9975E+02	5.0025E+02
Half scale (-)	-500	-5.0025E+02	-4.9975E+02
Full scale (-)	-1000	-1.00040E+03	-9.996E+02

Frequency verification

To verify frequency accuracy, you will:

- Apply accurate frequencies from the function generator to the terminals on the front panel of the DMM6500.
- Verify that the displayed readings are within specified limits.

Use the values in the table following the steps below to verify the performance of the DMM6500. Actual values depend on the published specifications (see [Example reading limit calculation](#) (on page 2-4)).

1. Connect the Keithley Instruments Model 3390 function generator to the DMM6500 INPUT HI and LO terminals as shown in the following figure.

Figure 6: Connections for frequency verification and adjustment

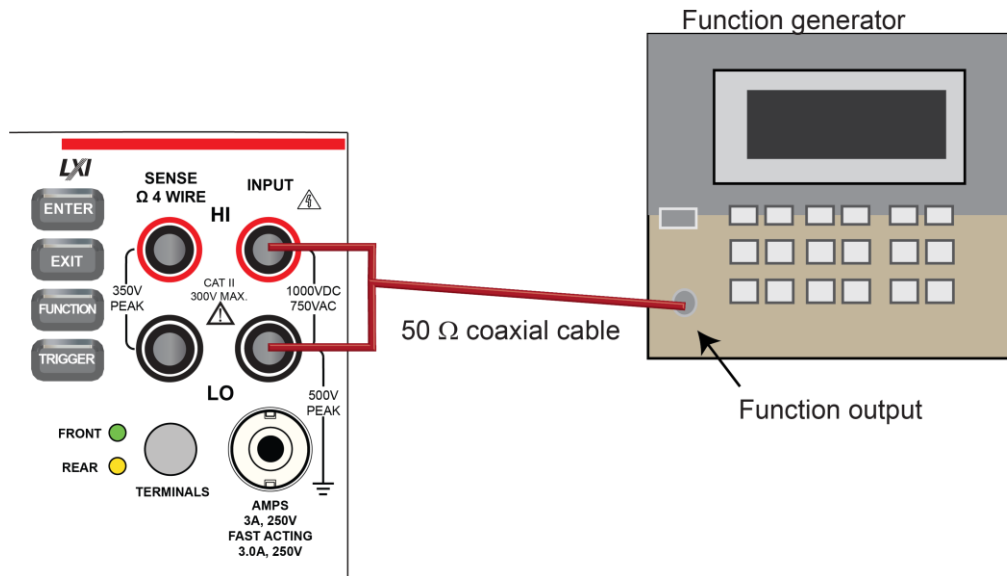

2. On the DMM6500, press the **FUNCTION** key, select the **Measure Functions** tab, and select **Frequency**.
3. Select the **MENU** key.
4. Under Measure, select **Settings**.
5. Set the Aperture to **250 ms**.
6. Set the Threshold Range to **10 V**.
7. Press the **HOME** key.
8. Source the voltage and frequency values as listed in [Verify the frequency](#) (on page 2-15). For each setting, be sure that the reading is within low and high limits.

Verify the frequency

Use the following values to verify the performance of the DMM6500. Actual values depend on published specifications (see [Example reading limit calculation](#) (on page 2-4)).

Description	Frequency (Hz)	Lower limit (Hz)	Upper limit (Hz)
10 Hz at 5 V	1.00E+01	9.99700E+00	1.000300E+01
1 kHz at 5 V	1.00E+03	9.999000E+02	1.000100E+03
10 kHz at 5 V	1.00E+04	9.999100E+03	1.000090E+04
100 kHz at 5 V	1.00E+05	9.999100E+04	1.000090E+05
300 kHz at 5 V	3.00E+05	2.999730E+05	3.000270E+05

Simulated thermocouple Type J temperature verification

To verify thermocouple accuracy, you will:

- Apply accurate voltages from the calibrator to the terminals on the front panel of the DMM6500.
- Verify that the displayed readings are within specified limits.

Thermocouple accuracy is verified by using a DC voltage calibrator to output values from standard thermocouple tables available from the National Institute of Standards and Technology (NIST) or other sources.

In the table following the steps below, three representative values are listed from a Type J thermocouple table for temperatures $-190\text{ }^{\circ}\text{C}$, $0\text{ }^{\circ}\text{C}$, and $750\text{ }^{\circ}\text{C}$, with their respective thermocouple voltages listed in the “Uncompensated calibrator source value” column. The calibrator source values are based on NIST Monograph 175, reference data 60, version 2.0.

Verify thermocouple accuracy

NOTE

Because the cable connecting the calibrator to the DMM6500 can have non-trivial thermal offset voltages, you must first correct for these to verify the DMM6500 specifications.

To verify the simulated thermocouple Type J temperature:

1. Connect the DMM6500 HI and LO INPUT terminals to the calibrator HI and LO terminals as shown in the following figure.

Figure 7: Connections for thermocouple verification

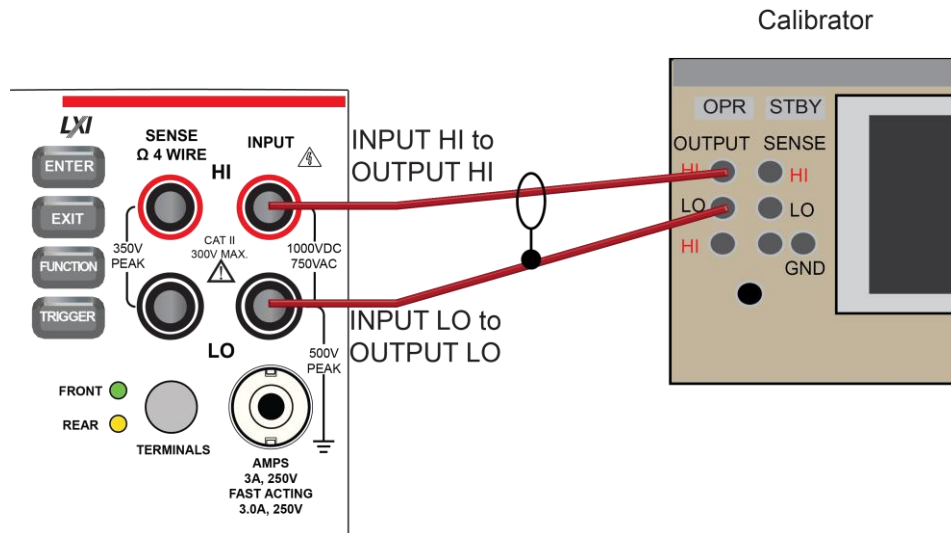

2. On the DMM6500, press the **FUNCTION** key and select **DC voltage**.
3. Press the **MENU** key.
4. Under Measure, select **Settings**.
5. Set the range to **100 mV**.
6. Set Input Impedance to **Auto**.
7. Set autozero to **On**.
8. Select the button next to Integration Rate. The Integration Rate dialog box opens.
9. Next to Unit, select **NPLC**.
10. Next to NPLC, select **1 PLC**.
11. Select **OK** and press the **HOME** key to return to the Home Screen.
12. Set the calibrator to output **0 V** and enable the output.
13. Allow five minutes for settling of the thermal voltage.
14. Record the measured offset voltage to 1 μV precision. If necessary, use the DMM6500 filter settings to reduce the noise of this measurement (for filter settings, go to **MENU > Measure Calculations**).
15. Press the DMM6500 **FUNCTION** key and select **Temperature**.
16. Press the **MENU** key.
17. Under Measure, select **Settings**.
18. On the Measure Settings screen, set the following values:
 - Units: **°C**
 - Transducer: **TC**
 - Thermocouple: **J**
 - Temperature (simulated reference temperature): **0 °C**
 - Integration Rate: **1 PLC**
 - Auto Zero: **On**

19. Set the calibrator to the simulated thermocouple voltage you want (from the following table), first correcting for the offset voltage measured in step 14. For example, if the measured offset voltage was $-2 \mu\text{V}$, set the calibrator to $-7.659 \text{ mV} - (-0.002 \text{ mV})$, which equals -7.657 mV , to simulate $-190 \text{ }^\circ\text{C}$.
20. Verify that the DMM6500 reading is within lower and upper limits.
21. Repeat steps 17 and 18 for each value in the following table.

Use the following values to verify the performance of the DMM6500. Actual values depend on published specifications (see [Example reading limit calculation](#) (on page 2-4)).

Simulated temperature	Uncompensated calibrator source value (V)	Lower limit	Upper limit
$-190 \text{ }^\circ\text{C}$	-7.659 mV	$-190.2 \text{ }^\circ\text{C}$	$-189.8 \text{ }^\circ\text{C}$
$0 \text{ }^\circ\text{C}$	0.000 mV	$-0.2 \text{ }^\circ\text{C}$	$0.2 \text{ }^\circ\text{C}$
$750 \text{ }^\circ\text{C}$	42.281 mV	$749.8 \text{ }^\circ\text{C}$	$750.2 \text{ }^\circ\text{C}$

Simulated RTD temperature verification

Use the following information to verify the performance of the DMM6500. Actual calibrator source values will vary. RTD verification is based on the calibrator sourcing resistance and the DMM6500 conversion of the resistance measurement to calculated temperature based on the Callendar-Van Dusen equation.

To verify RTD temperature accuracy, you will:

- Apply accurate resistance from the calibrator to the terminals on the front panel of the DMM6500.
- Verify that the displayed readings are within specified limits.

RTD equations

The temperature versus resistance readings listed in the RTD reference tables are calculated using the Callendar-Van Dusen equation. There are two equations that are based on different temperature ranges. There is an equation for the $-200 \text{ }^\circ\text{C}$ to $0 \text{ }^\circ\text{C}$ range and one for the $0 \text{ }^\circ\text{C}$ to $850 \text{ }^\circ\text{C}$ range.

Equation for $-200 \text{ }^\circ\text{C}$ to $0 \text{ }^\circ\text{C}$ temperature range

$$R_{RTD} = R_0 [1 + AT + BT^2 + CT^3(T - 100)]$$

where:

- R_{RTD} is the calculated resistance of the RTD
- R_0 is the known RTD resistance at $0 \text{ }^\circ\text{C}$
- T is the temperature in $^\circ\text{C}$
- $A = \alpha [1 + (\delta/100)]$
- $B = -1 (\alpha)(\delta)(1\text{E-}4)$
- $C = -1 (\alpha)(\beta)(1\text{E-}8)$

The alpha, beta, and delta values are listed in the following table.

Equation for 0 °C to 850 °C temperature range

$$R_{RTD} = R_0 (1 + AT + BT^2)$$

where:

- R_{RTD} is the calculated resistance of the RTD
- R_0 is the known RTD resistance at 0 °C
- T is the temperature in °C
- A = alpha [1 + (delta/100)]
- B = -1 (alpha)(delta)(1E-4)

The alpha and delta values are listed in the following table.

RTD parameters for equations

The RTD parameters for the Callendar-Van Dusen equations are listed in the following table.

DMM6500 resistance to temperature device (RTD)

Type	Standard	Alpha	Beta	Delta	R_0 at 0 °C (Ω)
PT100	ITS-90	0.00385055	0.10863	1.49990	100.0000
D100		0.003920	0.10630	1.49710	
F100		0.003900	0.11000	1.49589	
PT385	IPTS-68	0.003850	0.11100	1.50700	
PT3916		0.003916	0.11600	1.50594	

Verify the simulated RTD temperature

Use the values in the tables following the steps below to verify the performance of the DMM6500. Actual values depend on the published specifications (see [Example reading limit calculation](#) (on page 2-4)).

To verify RTD accuracy:

1. For 4-wire accuracy, connect the DMM6500 INPUT and SENSE terminals to the calibrator as shown in the following figure.

Figure 8: Connections for 4-wire RTD accuracy verification

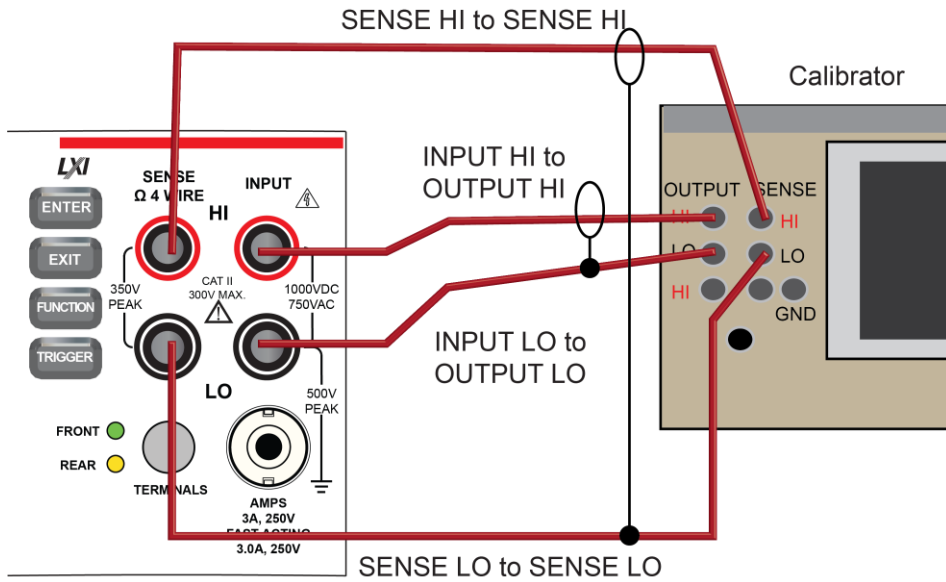

- For 3-wire accuracy, connect the DMM6500 INPUT and SENSE terminals to the calibrator as shown in the following figure.

NOTE

The SENSE HI wire is not required for 3-wire RTD measurements. For 3-wire RTD, accuracy is for < 0.1 Ω lead resistance mismatch for input HI and LO. Add 0.25 °C per 0.1 Ω of HI-LO lead resistance mismatch.

Figure 9: Connections for 3-wire RTD accuracy verification

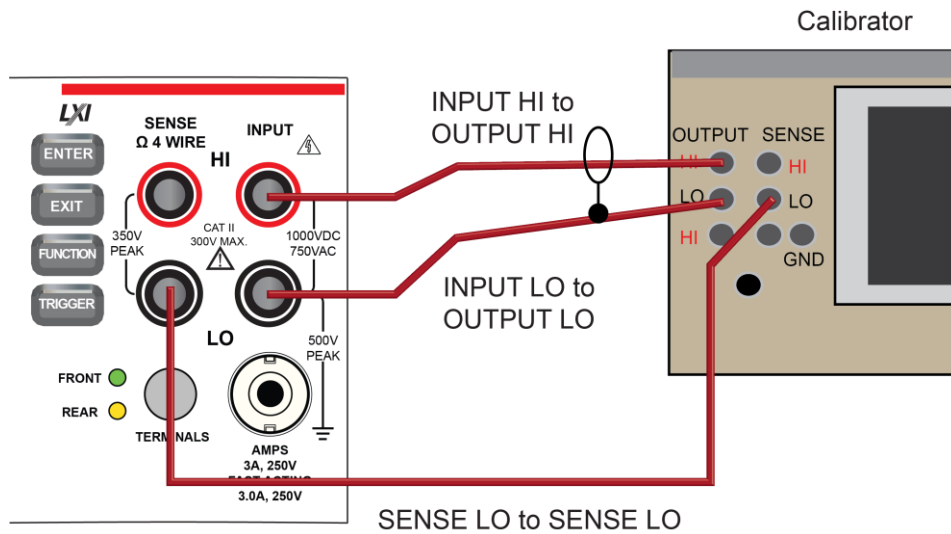

3. On the DMM6500, press the **FUNCTION** key and select **Temperature**.
4. Press the **MENU** key.
5. Under Measure, select **Settings**.
6. Select **Transducer**.
7. Set the Type to **4-wire RTD** or **3-Wire RTD**.
8. Set the RTD Type to **PT100**.
9. Press the **HOME** key.
10. On the calibrator, select **19 Ω** source resistance.
11. Select the **OPER** and **EX SNS** keys.
12. Record DMM6500 accuracies.
13. Refer to the table for PT100 accuracies.

NOTE

Fluke 5720 and 5730 resistance source values vary and may require new resistance-to-temperature target accuracy values.

14. Repeat for 100 Ω and 190 Ω source values.

Example	PT100	
	R₀	1.000000E+02
	alpha	3.850550E-03
	beta	1.086300E-01
	delta	1.499900E+00
	A	3.908304E-03
	B	-5.775440E-07
	C	-4.182852E-12

Nominal calibrator value (Ω)	Actual calibrator value (Ω)	Temperature (°C)	4-wire RTD	3-wire RTD
			±0.06 °C accuracy (±Ω from actual calibrator value)	±0.75 °C accuracy (±Ω from actual calibrator value)
19	18.999520	-198.8900	0.0259	0.3241
100	99.99707	-0.0075	0.0235	0.2932
190	189.99234	238.6775	0.0218	0.2725

Resistance verification

Use the following information to verify the performance of the DMM6500 resistance functions.

Four-wire resistance verification

To verify the 4-wire resistance function, you will:

- Use shielded, Teflon-insulated or equivalent cables in a 4-wire configuration.
- Characterize the calibrator 1 Ω and 10 Ω nominal values with an external reference digital multimeter (DMM); verify accuracy from the reference DMM readings.
- For the 100 Ω to 100 M Ω ranges, verify accuracy from actual calibrator source values.
- Verify that the displayed readings are within specified limits.

Verify 4-wire resistance accuracy

To verify 4-wire resistance accuracy:

1. Connect the DMM6500 INPUT and SENSE terminals to the calibrator as shown in the following figure.

Figure 10: Connections for 4-wire resistance accuracy verification

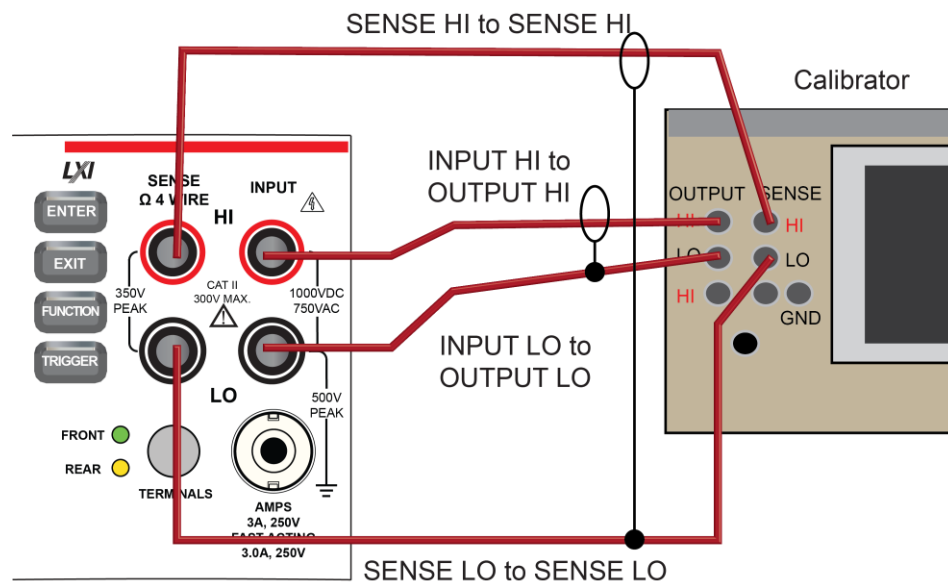

2. Set the calibrator for 4-wire resistance with external sense on.
3. On the DMM6500, press the **FUNCTION** key and select **4W Res.**
4. Press the **MENU** key.
5. Under Measure, select **Settings**.
6. Set Offset Compensation **On**.
7. Verify that Open Lead Detector is **Off**.
8. On the Home screen, select the button next to Range and select **1 Ω** .
9. Source the nominal zero and full-scale resistance values for the 1 Ω to 10 k Ω ranges. Source the nominal zero value for the 100 k Ω range. Refer to the tables in [Calculated limits](#) (on page 2-22).

10. For the 100 kΩ range, only verify 0 Ω with Offset Compensation set to **On**.
11. Set Offset Compensation to **Off**.
12. Verify full-scale 100 kΩ on the 100 kΩ range and 0 and full-scale for the 1 MΩ and 10 MΩ ranges.
13. Verify that the readings are within calculated limits.

NOTE

When Offset Compensation is set to On, ranges are limited to 1 Ω to 10 kΩ. When Offset Compensation is set to Off, all ranges (1 Ω to 100 MΩ) are available from all interfaces.

You can use either the front-panel controls or remote interface commands to set measurement parameters for verification. For calibration, you must use remote interface commands. The example below is an example of remote interface commands that will generate event messages.

To do the same steps over the remote interface, send the commands:

```
dmm.measure.func = dmm.FUNC_4W_RESISTANCE
dmm.measure.offsetcompensation.enable = dmm.OCOMP_ON
dmm.measure.range = 1e6
```

The following warning message is displayed:

```
1131, Parameter, measure range, expected value from 1 to 100000
```

Set `dmm.measure.offsetcompensation.enable = dmm.OCOMP_OFF`, and then set `dmm.measure.range = 1e6` to run without warnings.

Verify that the readings are within calculated limits.

The values and limits in the following tables are for example only. You must calculate test limits based on the actual resistance values output by your calibrator or resistance source (see [Example reading limit calculation](#) (on page 2-4)).

Range (Ω)	Nominal calibrator values (Ω)	Typical reference DMM reading (Ω)	Lower limit (Ω)	Upper limit (Ω)
1	0	n/a	-2.00E-04	2.00E-04
	1.00E+00	1.000157E+00	0.999872E+00	1.000442E+00
10	0.00E+00	n/a	-2.00E-04	2.00E-04
	1.00E+01	9.999450E+00	9.99840E+00	1.000050E+01

Range (Ω)	Nominal calibrator values (Ω)	Actual calibrator value (Ω)	Lower limit (Ω)	Upper limit (Ω)
100	0.00E+00	n/a	-2.00E-03	2.00E-03
	1.00E+02	9.9996340E+01	9.99858E+01	1.000068E+02
1000	0.00E+00	n/a	-6.00E-03	6.00E-03
	1.00E+03	9.9998410E+02	9.999031E+02	1.000065E+03
1.0E+04	0.00E+00	n/a	-6E-02	6E-02
	1.00E+04	9.9999050E+03	9.99905E+03	9.99999E+03
1.0E+05	0.00E+00	n/a	-1.00E+00	1.00E+00

Four-wire resistance verification with offset compensation off

The values and limits in the following tables are for example only. You must calculate test limits based on the actual resistance values output by your calibrator or resistance source (see [Example reading limit calculation](#) (on page 2-4)).

NOTE

For 10 MΩ verification, the Sense HI cable is optional. Measurement is with Input HI and LO and Sense LO only.

Range (Ω)	Nominal calibrator values (Ω)	Actual calibrator value (Ω)	Lower limit (Ω)	Upper limit (Ω)
1.0E+05	1.00E+05	1.0000060E+05	9.99921E+04	1.000091E+05
1.0E+06	0.00E+00	n/a	-6.00E+00	6.00E+00
	1.00E+06	9.99851E+05	1.000063E+06	1.000063E+06
1.0E+07	0.00E+00	n/a	-1.00E+02	1.00E+02
	1.00E+07	9.9989960E+06	9.99440E+06	1.000360E+07

Verify 2-wire resistance accuracy

To verify the 2-wire resistance function 100 MΩ range, you will:

- Use shielded, Teflon-insulated or equivalent cables in a 2-wire configuration.
- Apply accurate resistance from the calibrator to the terminals on the front panel of the DMM6500.
- Verify that the displayed readings are within specified limits.

Verify resistance 100 MΩ range

To verify the 100 MΩ range:

1. Connect the DMM6500 INPUT to the calibrator as shown in the following figure.

Figure 11: Connections for 100 MΩ verification

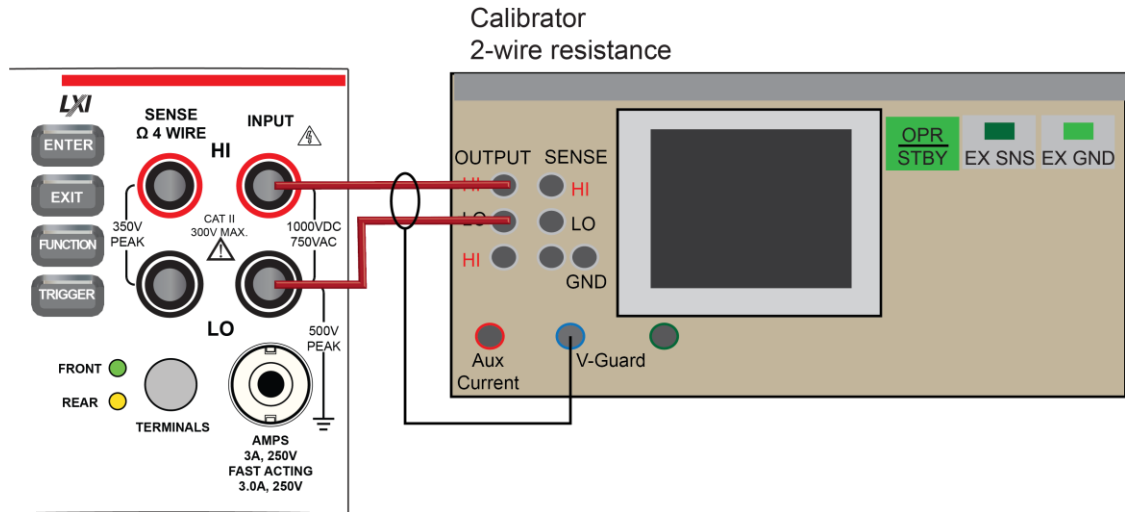

2. Set the calibrator for 2-wire resistance with external sense off.
3. On the DMM6500, press the **FUNCTION** key and select **2W Res.**
4. On the Home screen, select the button next to Range and select **100 MΩ**.
5. Source the nominal full-scale resistance values for the 100 MΩ range as shown in the following table.

The values and limits in the following tables are for example only. You must calculate test limits based on the actual resistance values output by your calibrator or resistance source (see [Example reading limit calculation](#) (on page 2-4)).

Range	Nominal calibrator values (Ω)	Actual calibrator (Ω)	Lower limit (Ω)	Upper limit (Ω)
1.0E+08	0.00E+00		-3.00E+03	3.00E+03
	1.00E+08	1.0000380E+08	9.980079E+07	1.002068E+08

DC current verification

The DMM6500 DC current ranges can be verified using several methods, depending on the level of measurement uncertainty required. This manual describes the verification procedure using a Fluke 8508A reference digital multimeter (DMM) in series with the DMM6500 to determine the nominal test current value for the 10 μA to 100 mA ranges. For the 1 A to 10 A ranges, this manual describes using direct output from a Fluke Model 5720A or 5725A calibrator.

NOTE

These configurations are adequate for most purposes, but may not provide sufficient test uncertainty ratio (TUR) for some users. You must evaluate the measurement uncertainties and ensure that they are adequate for your use.

DC current 10 μA to 100 mA range verification

When verifying DC current on the 10 μA to 100 mA ranges, systematic calibrator and cable offsets must be compensated and test limits calculated based on reference digital multimeter (DMM) readings.

In the following section, offset measurements may exceed DMM6500 zero-current measurement specifications due to systematic source offset current from the test setup.

NOTE

To verify the DMM6500 specifications with zero input current, disconnect all cables and calibrators from the DMM6500 input. This is a separate setup from that used in the procedure below for mid-scale and full-scale readings.

To prepare the DMM6500 for DC current accuracy verification:

1. Set up the DMM6500 for DC current and the range being tested. Make sure relative offset is disabled.
2. Connect the calibrator, DMM6500, and reference DMM as shown in the following figure.

Figure 12: Connection for DC current

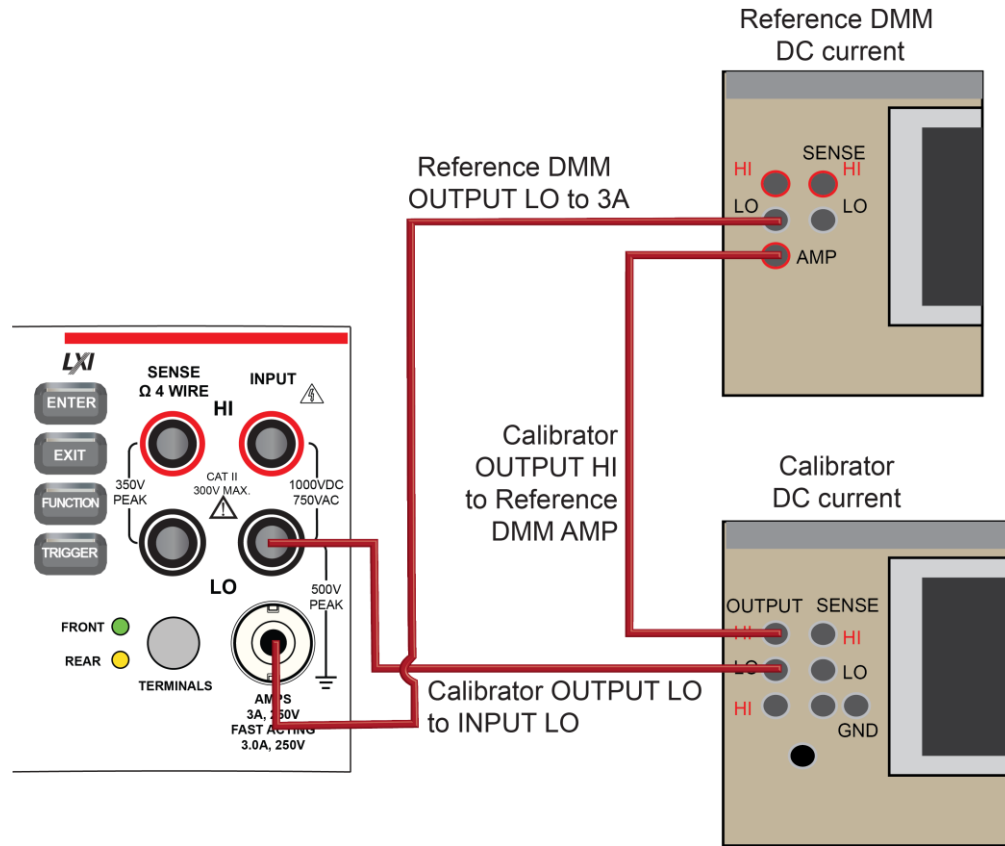

To verify DMM6500 accuracy for each range:

1. Set the calibrator to source zero current.
2. Set the reference DMM to **DC Current** and select the appropriate range to be verified. Use the Model 8508A 200 μA range to verify the DMM6500 10 μA and 100 μA ranges. Use the Model 8508A 2 mA, 20 mA, and 200 mA ranges to verify the DMM6500 1 mA, 10 mA, and 100 mA ranges, respectively.
3. On the calibrator, select the **OPR/STBY** key. Make sure that the front panel displays **OPERATE**.
4. On the DMM6500, press the **MENU** key.
5. Select **Calculations**. The Calculation Settings screen is displayed.
6. Select the button next to Rel and select **On** to enable the relative offset function.
7. Set the Rel Value to **0** to zero system offset values.
8. On the reference DMM, zero the range for system offset.
9. Set the calibrator to source the current for the range you are verifying (listed in the 1 mA verification table in Test limit calculation for 10 μA to 100 mA ranges).

10. Note the offset-compensated reference DMM reading, and calculate limits based on DMM6500 specifications (use the reference DMM reading as the expected value and verify the DMM6500 accuracy from the calculated reference DMM current).
11. Repeat steps 1 through 10 for all ranges (10 µA through 100 mA).

Test limit calculation for 10 µA to 100 mA ranges

The following tables list nominal test current for 10 µA to 100 mA ranges. Test limits must be calculated relative to actual current, as determined by the reference digital multimeter (DMM) measurement. For example, using a specification of 60 ppm of reading + 9 ppm of range on the 10 mA range, the reference DMM measures 5.00012 mA on the nominal 5 mA test.

$$\text{Specification tolerance} = 5.00012 \text{ (mA)} \times 60 \text{ ppm} + 10 \text{ (mA)} \times 9 \text{ ppm} = 0.000390072 \text{ mA}$$

$$\text{Lower test limit} = 5.00012 - 0.000390072 = 4.999729928 \text{ mA}$$

$$\text{Upper test limit} = 5.00012 + 0.000390072 = 5.000510072 \text{ mA}$$

Although the specification tolerance calculated above from the actual test current differs slightly from the values listed in the table (based on nominal value), this difference is generally much smaller than the measurement uncertainty and can be ignored. As a result, the test limits can be calculated from the table specification tolerance as:

$$\text{Lower test limit} = 5.00012 - 0.00039 = 4.99973 \text{ mA}$$

$$\text{Upper test limit} = 5.00012 + 0.00039 = 5.00051 \text{ mA}$$

Range	Nominal input (µA)	Specification tolerance (µA) (based on nominal)
10 µA	0	REL
	10	0.00500
	5	0.00275
	-5	0.00275
	-10	0.00500

Range	Nominal input (µA)	Specification tolerance (µA) (based on nominal)
100 µA	0	REL
	100	0.0500
	50	0.0275
	-50	0.0275
	-100	0.0500

Range	Nominal input (mA)	Specification tolerance (mA) (based on nominal)
1 mA	0	REL
	1	0.000500
	0.5	0.000275
	-0.5	0.000275
	-1	0.000500

Range	Nominal input (mA)	Specification tolerance (mA) (based on nominal)
10 mA	0	REL
	10	0.00250
	5	0.00150
	-5	0.00150
	-10	0.00250

DC current 100 mA to 3 A range verification

To verify DC current accuracy on the 100 mA to 3 A ranges, you will:

- Apply accurate current from the DC current calibrator directly to the DMM6500 front-panel terminals.
- Verify that the displayed readings are within specified limits.

To verify DC current accuracy:

1. Set up the DMM6500 for DC current and the range being tested. Make sure that relative offset is disabled.
2. Connect the DMM6500 and calibrator as shown in the following figure.

Figure 13: Connections for 100 mA to 3 A range verification

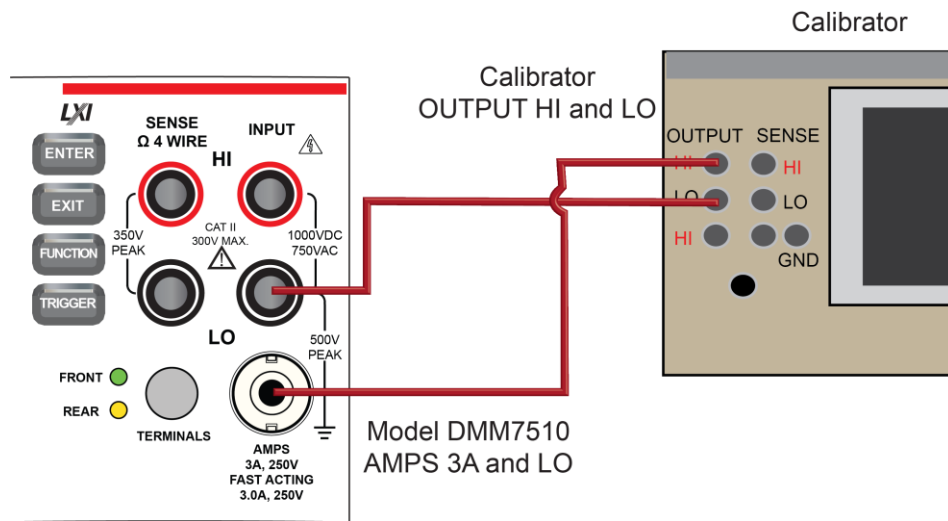

Zero verify the DMM6500:

1. On the calibrator, select the **OPR/STBY** key. Make sure that the front panel displays **STANDBY**.
2. Set the ranges to 100 mA.
3. Verify the DMM6500 zero reading for each range.

Apply a relative offset:

1. On the calibrator, select the **OPR/STBY** key. Make sure that the front panel displays **OPERATE**.
2. Set the calibrator to source zero current and apply the relative offset to the DMM6500.
3. Source DC current from the following table. For each setting, be sure that the reading is within stated limits.
4. Repeat these steps for the 1 A and 3 A ranges.

Verify DC current 100 mA range

Description	Calibrator setpoint (A)	Lower limit	Upper limit
UUT zero	STANDBY	REL	n/a
Full scale (+)	0.1	9.9975E-02	1.000250E-01
Half scale (+)	0.05	4.9985E-02	5.0015E-02
Half scale (-)	-0.05	-5.0015E-02	-4.9985E-02
Full scale (-)	-0.1	-1.000250E-01	-9.99750E-02

Verify DC current 1 A range

Description	Calibrator setpoint (A)	Lower limit	Upper limit
UUT zero	STANDBY	REL	n/a
Full scale (+)	1	9.99550E-01	1.000450E+00
Half scale (+)	0.5	4.99750E-01	5.002500E-01
Half scale (-)	-0.5	-5.00250E-01	-4.99750E-01
Full scale (-)	-1	-1.000450E+00	-9.99550E-01

Verify DC current 3 A range

Description	Calibrator setpoint (A)*	Lower limit	Upper limit
UUT zero	STANDBY	REL	n/a
2/3 scale (+)	2	1.998680E+00	2.001320E+00
Half scale (+)	1.5	1.498980E+00	1.501020E+00
Half scale (-)	-1.5	-1.501020E+00	-1.498980E+00
1/3 scale (-)	-2	-2.001320E+00	-1.998680E+00

* The 3 A range full-scale test points are limited to 2 A in this table because of the accuracy limitations of Fluke Models 57xxA and 5725A series calibrators at currents above 2.2 A.

Verify DC current 10 A range

See [DC current 10 A range verification](#) (on page 2-37) under [Rear-panel verification](#) (on page 2-37).

Digitize current verification

The following topics describe how to verify digitized DC current on the DMM6500.

Digitize DC current verification 10 µA to 3 A ranges

To verify digitize DC current accuracy:

1. Connect the DMM6500 and calibrator as shown in the following figure.

Figure 14: Connections for digitize DC current 10 µA to 3 A range verification

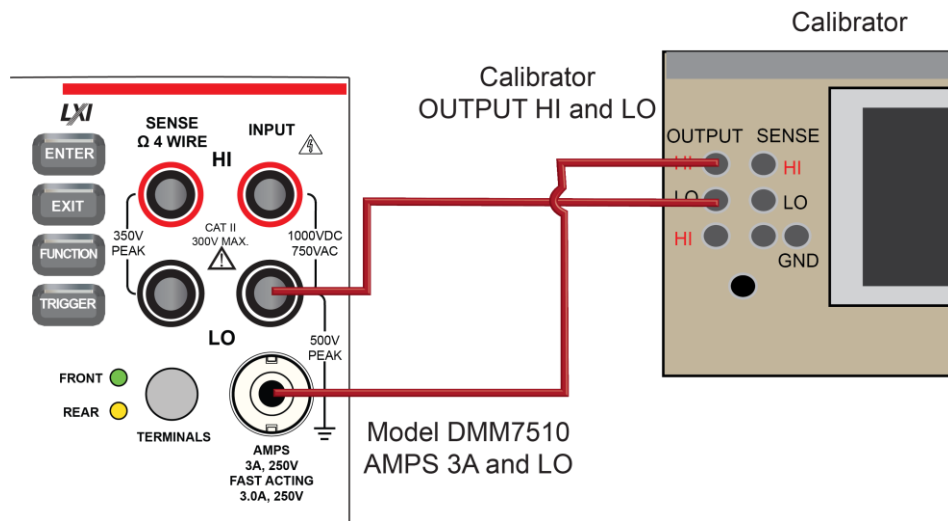

2. Press the **FUNCTION** key.
3. Select the **Digitize Functions** tab and select **Digitize Current**.
4. Press the **HOME** key.
5. Set the Range to **10 µA**.
6. Press the **MENU** key.
7. Under Measure, select **Settings**.
8. Set the Sample Rate to **1000**.
9. Set the Aperture to **Auto** or **1 ms**.
10. Set the Count to **100**.
11. Apply a relative offset:
 - a. Set the calibration current output to **NORMAL**.
 - b. Set the calibrator output to **0 A**.
 - c. On the calibrator, select the **OPR/STBY** key. Make sure that the front panel displays *OPERATE*.
 - d. On the DMM6500, press the **MENU** key.
 - e. Select **Calculations**.
 - f. Select **Rel Acquire**.
12. Source positive and negative full-scale and half-scale currents, as listed in the following tables.
13. Repeat these steps for the 100 µA to 3 A range settings listed in the following tables.

Verify digitize current 100 µA range

Description	Calibrator setpoint (A)	Lower limit	Upper limit
UUT zero	0	REL	n/a
Full scale (+)	0.00010	9.988E-05	1.0012E-04
Half scale (+)	0.00005	4.9985E-05	5.0015E-05
Half scale (-)	-0.00005	-5.0015E-05	-4.9985E-05
Full scale (-)	-0.00010	-1.0012E-04	-9.988E-05

Verify digitize current 1 mA range

Description	Calibrator setpoint (A)	Lower limit	Upper limit
UUT zero	0	REL	n/a
Full scale (+)	0.001	9.99000E-04	1.00100E-03
Half scale (+)	0.0005	4.9935E-04	5.0065E-04
Half scale (-)	-0.0005	-5.0065E-04	-4.9935E-04
Full scale (-)	-0.001	-1.00100E-03	-9.99000E-04

Verify digitize current 10 mA range

Description	Calibrator setpoint (A)	Lower limit	Upper limit
UUT zero	0	REL	n/a
Full scale (+)	0.01	9.99200E-03	1.00080E-02
Half scale (+)	0.005	4.99450E-03	5.00550E-03
Half scale (-)	-0.005	-5.00550E-03	-4.99450E-03
Full scale (-)	-0.01	-1.00080E-02	-9.99200E-03

Verify digitize current 100 mA range

Description	Calibrator setpoint (A)	Lower limit	Upper limit
UUT zero	0	REL	n/a
Full scale (+)	0.1	9.99200E-02	1.00080E-01
Half scale (+)	0.05	4.99450E-02	5.00550E-02
Half scale (-)	-0.05	-5.00550E-02	-4.99450E-02
Full scale (-)	-0.1	-1.00080E-01	-9.99200E-02

Verify digitize current 1 A range

Description	Calibrator setpoint (A)	Lower limit	Upper limit
UUT zero	0	REL	n/a
Full scale (+)	1	9.99900E-01	1.00100E+00
Half scale (+)	0.5	4.99350E-01	5.00650E-01
Half scale (-)	-0.5	-5.00650E-01	-4.99350E-01
Full scale (-)	-1	-1.00100E+00	-9.99900E-01

Verify digitize current 3 A range

Description	Calibrator setpoint (A)*	Lower limit	Upper limit
UUT zero	0	REL	n/a
2/3 scale (+)	2	1.99700E+00	2.00300E+00
Half scale (+)	1.5	1.49745E+00	1.50255E+00
Half scale (-)	-1.5	-1.50255E+00	-1.49745E+00
2/3 scale (-)	-2	-2.00300E+00	-1.99700E+00

* The 3 A range full-scale test points are limited to 2 A in this table because of the accuracy limitations of Fluke Models 57xxA and 5725A series calibrators at currents above 2.2 A.

Verify digitize current 10 A range

See [Digitize current 10 A range verification](#) (on page 2-39) under [Rear-panel verification](#) (on page 2-37).

AC current verification

The following topics describe how to verify AC current.

Verify AC current on the 100 µA to 3 A ranges

To verify AC current accuracy, you will:

- Apply accurate voltages from the Fluke 5720A or 5730A multifunction calibrator to the DMM6500 front-panel terminals.
- Verify that the displayed readings fall within specified limits.

Use the values in the following tables to verify the performance of the DMM6500. Actual values depend on the published specifications (see [Example reading limit calculation](#) (on page 2-4)).

To verify AC current accuracy:

1. On the DMM6500, press the **FUNCTION** key and select **AC Current**.
2. Press the **HOME** key.
3. Set the range you are verifying.
4. Press the **MENU** key.
5. Under Measure, select **Settings**.
6. Make sure that Detector Bandwidth is set to **30 Hz**.

NOTE

AC current is specified for the detector bandwidth setting of 3 Hz. 3 Hz measures accurately for input signals from 3 Hz to 10 kHz, with reading rates of ≈ 0.5 readings/s. To improve verification throughput to ≈ 3.3 readings/s, set detector bandwidth to 30 Hz for frequencies of 30 Hz to 10 kHz. To verify frequencies 1 kHz and higher, set the detector bandwidth to 300 Hz for faster ≈ 55 readings/s throughput.

7. Connect the DMM6500 to the calibrator as shown in the following figure.

Figure 15: Connections for AC current verification

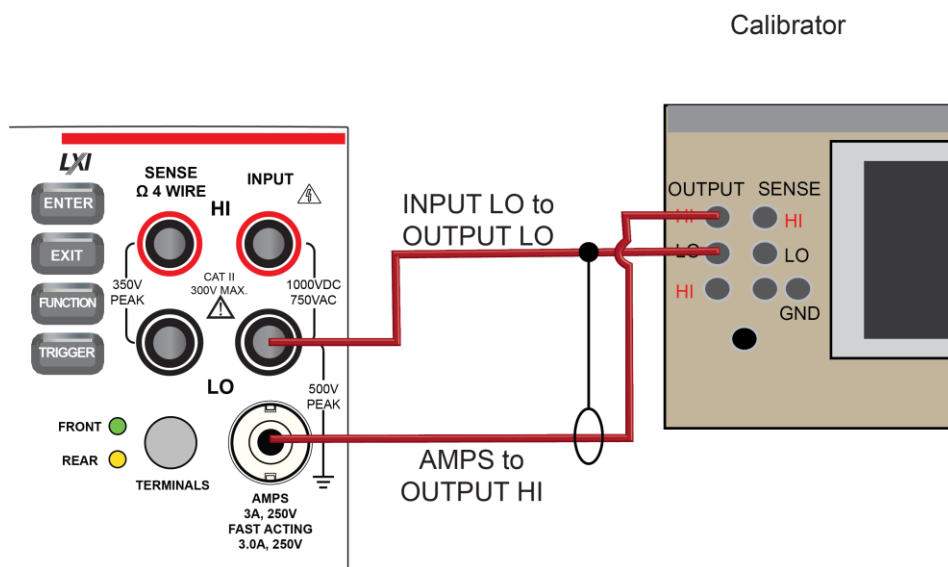

8. Source AC current for each of the frequencies listed in the following tables. For each setting, make sure that the reading is within low and high limits.

Verify AC current 100 μ A range

Description	Verification point	Lower limit	Upper limit
100 μ A at 40 Hz	0.0001	9.983000E-04	1.001700E-03
100 μ A at 1 kHz	0.0001	9.983000E-04	1.001700E-03

Verify AC current 1 mA range

Description	Verification point	Lower limit	Upper limit
1 mA at 40 Hz	0.001	9.986000E-04	1.001400E-03
1 mA at 1 kHz	0.001	9.986000E-04	1.001400E-03
1 mA at 5 kHz	0.001	9.986000E-04	1.001400E-03

Verify AC current 10 mA range

Description	Verification point	Lower limit	Upper limit
10 mA at 40 Hz	0.010	9.986000E-03	1.001400E-02
10 mA at 1 kHz	0.010	9.986000E-03	1.001400E-02
10 mA at 5 kHz	0.010	9.986000E-03	1.001400E-02

Verify AC current 100 mA range

Description	Verification point	Lower limit	Upper limit
100 mA at 40 Hz	0.1	9.986000E-02	1.001400E-01
100 mA at 1 kHz	0.1	9.986000E-02	1.001400E-01
100 mA at 5 kHz	0.1	9.986000E-02	1.001400E-01

Verify AC current 1 A range

Description	Verification point	Lower limit	Upper limit
1 A at 40 Hz	1.000	9.986000E-01	1.001400E+00
1 A at 1 kHz	1.000	9.986000E-01	1.001400E+00
1 A at 5 kHz	1.000	9.986000E-01	1.001400E+00

Verify AC current 3 A range

Description	Verification point	Lower limit	Upper limit
2 A at 40 Hz	2.000	1.995200E+00	2.004800E+00
2 A at 1 kHz	2.000	1.995200E+00	2.004800E+00
2 A at 5 kHz	2.000	1.995200E+00	2.004800E+00

Verify AC current 10 A range

See [AC current 10 A verification](#) (on page 2-40) under [Rear-panel verification](#) (on page 2-37).

Capacitance verification

To compensate for capacitance offset of the cable and 1 μF thru 100 μF decade box:

1. Connect the DMM6500, shielded banana cable, banana to dual BNC shielded cable, and 1 μF through 100 μF decade capacitor box as shown in the following diagram.

Figure 16: Connect DMM6500 to decade capacitor box

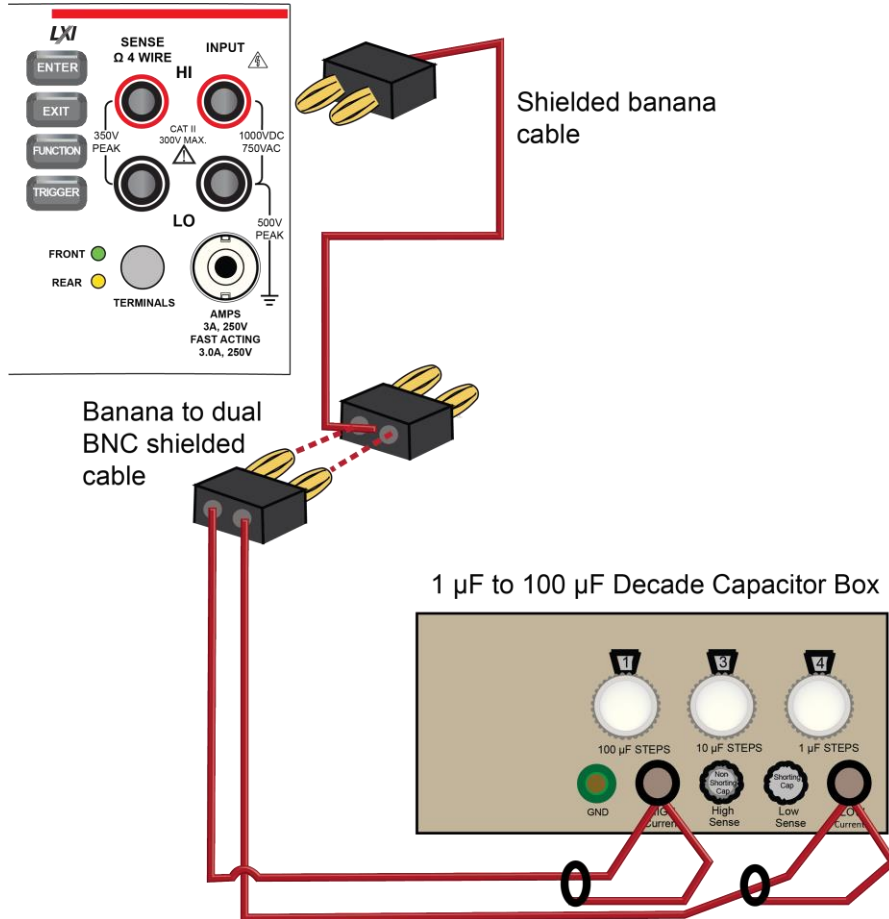

2. Set the decade capacitor box to **0 F**.
3. On the DMM6500, press the **FUNCTION** key, select the **Measure Functions** tab, and select **Capacitance**.
4. Press the **MENU** key.
5. Under Measure, select **Settings**.
6. Set the Range to **1 nF**.

7. Press the **MENU** key.
8. Select **Calculations** and select **Rel**, then **Acquire**.

NOTE

Cabling could be as high as ≈ 300 pF, which could prevent full-scale verification due to the large cable capacitance offset. Cable lengths should be minimized to reduce cable capacitance as much as possible.

9. Connect the shielded banana cable to the 1 nF to 1 μ F Decade Capacitor Box as shown in the figure below.

Figure 17: Capacitance verification connections

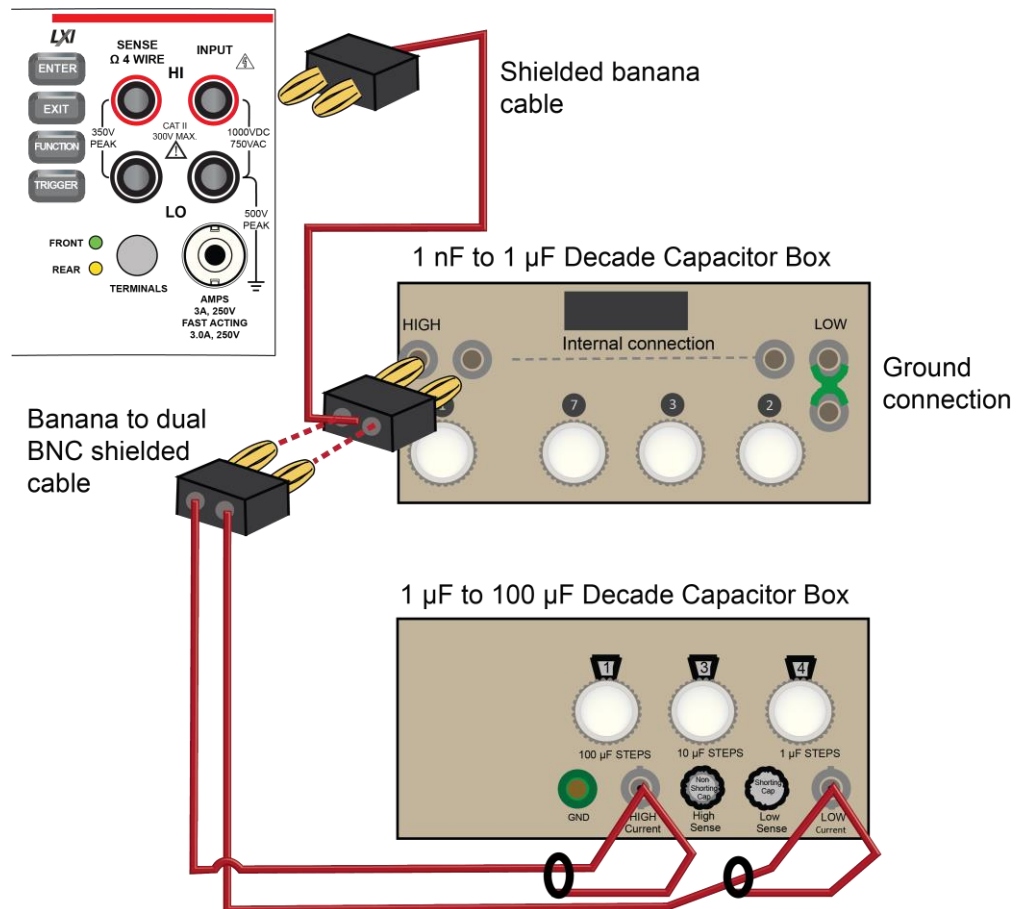

10. Verify capacitance following the verification points and accuracies from the table below.

Verify the capacitance

Description	Verification point	Lower limit (F)	Upper limit (F)
1 nF range cable REL	3.00E-10	n/a	n/a
10% 1 nF range	1.0000E-10	9.4200E-11	1.0580E-10
70% 1 nF range	7.0000E-10	6.8940E-10	7.1060E-10
10% 10 nF range	1.0000E-09	9.8600E-10	1.0140E-09
100% 10 nF range	1.0000E-08	9.9500E-09	1.0500E-08
10% 100 nF range	1.0000E-08	9.8600E-09	1.0140E-08
100% 100 nF range	1.0000E-07	9.9500E-08	1.0050E-07
10% 1 µF range	1.0000E-07	9.8600E-08	1.0140E-07
100% 1 µF range	1.0000E-06	9.9500E-07	1.0050E-06
10% 10 µF range	1.0000E-06	9.8600E-07	1.0140E-06
100% 10 µF range	1.0000E-05	9.9500E-06	1.0050E-05
10% 100 µF range	1.0000E-05	9.8600E-06	1.0140E-05
100% 100 µF range	1.0000E-04	9.9500E-05	1.0050E-04

Verifying zero values using a 4-wire short

NOTE

Four-wire short verifications are not included in the Customer Calibration Data Report.

To verify zero values using a 4-wire short, you will:

- Check the zero values of various test points with 4-wire connections to the DMM6500 front or rear terminals.
- Verify that the displayed readings are within specified limits.

Verify resistance zero values using a 4-wire short

To verify resistance zero values:

1. Select the **4W Res** function.
2. Set the DMM6500 to the **1Ω** range.
3. Press the **MENU** key.
4. Under Measure, select **Settings**.
5. Set the Offset Compensation to **On**.
6. Connect the Model 8610 or 8620 4-wire short to the front panel as shown in the following figure.
7. Allow to settle for 5 minutes. Do not use relative offset.

Figure 18: Front panel 4-wire shorting plug orientation

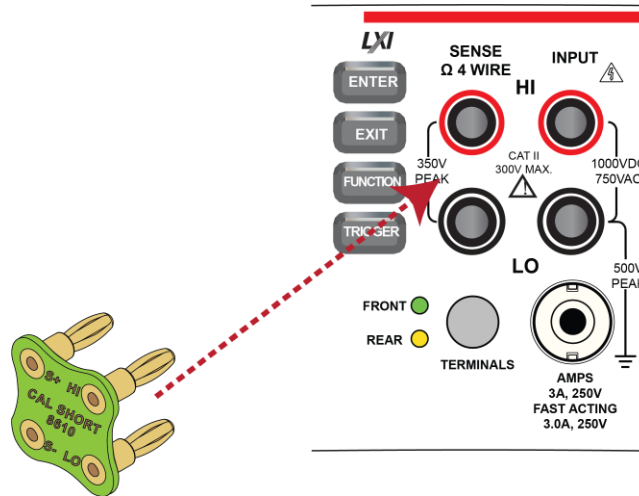

8. Verify that the 1 Ω range is within specification (see the following table).
9. Repeat verification for the 10 Ω to 100 kΩ ranges.

Verify 4-wire resistance zero values

Range (Ω)	Lower limit	Upper limit
1	-2.00E-04	2.00E-04
10	-2.00E-04	2.00E-04
100	-2.00E-03	2.00E-03
1 k	-6.00E-03	6.00E-03
10 k	-6.00E-02	6.00E-02
100 k	-1.00E+00	1.00E+00

Verify DC voltage zero values using the 4-wire short

To verify DC voltage zero values:

1. Leave the short connected as described in [Verify resistance zero values using a 4-wire short](#) (on page 2-35).
2. Press the **FUNCTION** key.
3. Select the **DC Voltage** function.
4. Press the **HOME** key.
5. Set the range to **1000 V**.

NOTE

DC voltage verification is done in descending range order, starting with the 1000 V range and finishing on the 100 mV range.

6. Verify that the 1000 V range zero is within specification. See the table below.
7. Verify that the 100 V to 100 mV range zero is within specification.

Verify DC voltage zero values

Range	Lower limit	Upper limit
1000	-6.00E-03	6.00E-03
100	-6.00E-04	6.00E-04
10	-5.00E-05	5.00E-05
1	-6.00E-06	6.00E-06
100 mV	-3.50E-06	3.50E-06

Rear-panel verification

The following topics describe verification procedures that are done with connections attached to the terminals on the DMM6500 rear panel.

DC current 10 A range verification

To verify 10 A range:

1. Set the TERMINALS switch to **REAR**.
2. Press the **FUNCTION** key and select **DC Current**.
3. Press the **HOME** key.
4. Set the range to **10A**.
5. Connect the DMM6500, reference DMM, calibrator, and amplifier as shown in the following figure.

CAUTION

Ensure cabling is designed to conduct 10 A without significant voltage drop. In general, cables for the 10 A range steps should be made of heavy gauge wire and should be as short as practical.

Figure 19: Connections for DC current verification 10 A range

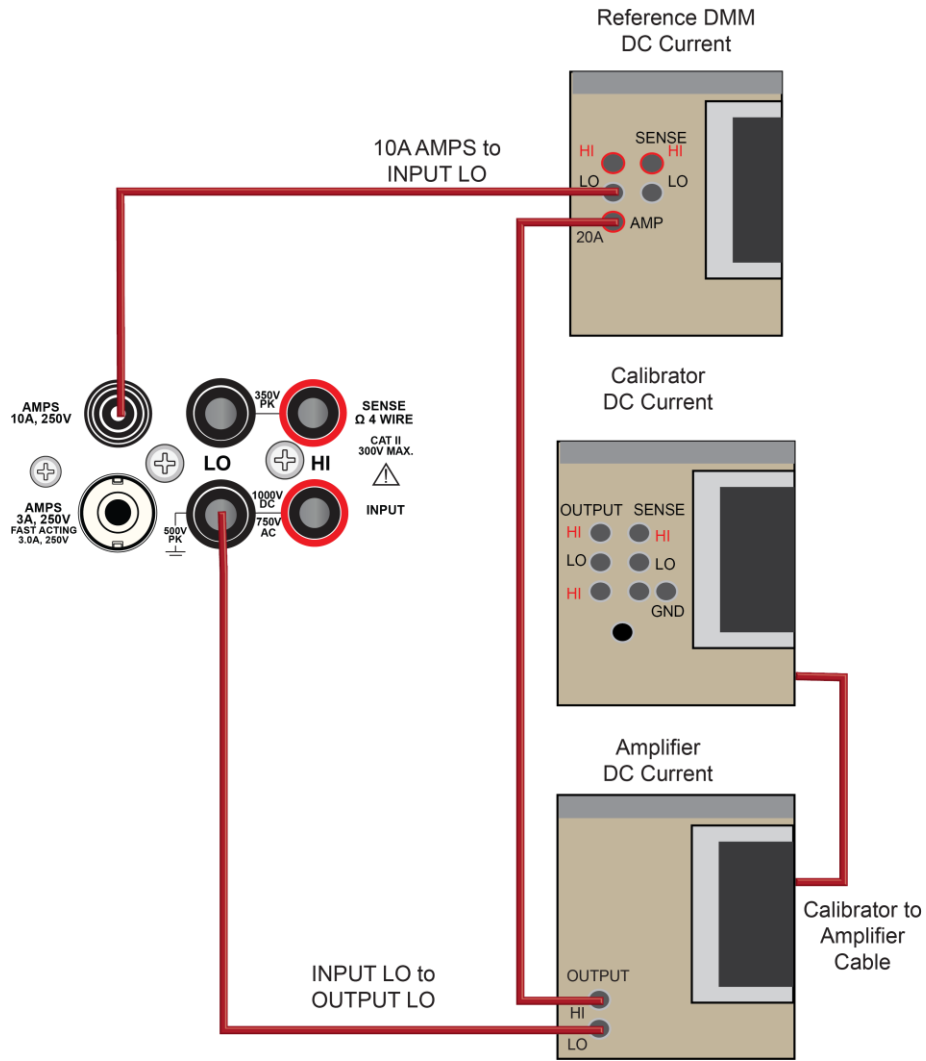

Apply a relative offset to the DMM6500:

1. On the calibrator, select the **OPR/STBY** key. Ensure that the front panel displays **STANDBY**.
2. Verify the DMM6500 zero reading.
3. Verify the DC current verification points and reference DMM readings from the following table.

Verify DC current 10 A range

Description	Nominal input	Typical measured input (A)	Lower limit	Upper limit
UUT Zero	STANDBY		-2.750E-03	2.750E-03
System zero	0.00E+00	4.80E-04	REL	REL
Full scale (+)	10	9.99961	9.9818606E+00	1.0017359E+01
Half scale (+)	5	4.99984	4.9895902E+00	5.0100898E+00
Half scale (-)	-5	-5.00079	-5.0110412E+00	-4.9905388E+00
Full scale (-)	-10	-10.0016	-1.0019352E+01	-9.9838476E+00

Digitize current 10 A range verification

CAUTION

Ensure cabling is designed to conduct 10 A without significant voltage drop. In general, cables for the 10 A range steps should be made of heavy gauge wire and should be as short as practical.

To verify the 10 A range:

1. Connect DMM6500, calibrator, and amplifier as shown in the following figure.

Figure 20: Connections for the 10 A range

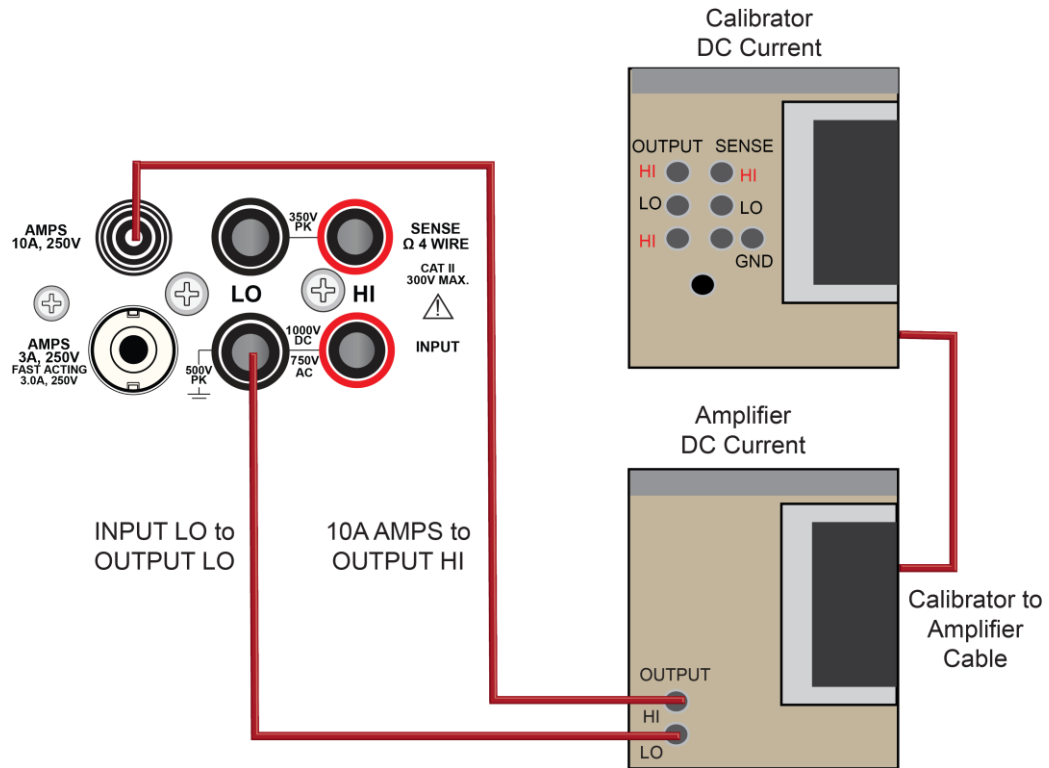

2. Set the TERMINALS switch to **REAR**.
3. Press the **FUNCTION** key, select the **Digitize Functions** tab, and select **Digitize Current**.
4. Press the **HOME** key.
5. Set the range to **10A**.
6. Press the **MENU** key.
7. Under Measure, select **Settings**.
8. Set the sample rate to **1000**.
9. Set the aperture to **Auto** or **1 ms**.
10. Set the count to **100**.

Verify the DMM6500 zero:

1. On the calibrator, select the **OPR/STBY** key. Make sure that the front panel displays **STANDBY**.
2. Verify the DMM6500 zero reading for each range.

Apply a relative offset to the system:

1. On the calibrator, select the **OPR/STBY** key. Make sure that the front panel displays **OPERATE**.
2. Enable the calibrator Amplifier and select the **BOOST** key.
3. On the calibrator, set the amplifier range lock to **ON**.
4. Set the calibrator output to **0.00000 ADC** and allow the reading to settle.
5. Press the **MENU** key.
6. Select **Calculations**.
7. Select **Rel** and **Acquire**.
8. Source positive and negative full-scale and half-scale currents, as listed in the following table.
9. Verify that the STATISTICS swipe screen reading for average is within low and high limits.

Verify digitize current 10 A range

Description	Calibrator setpoint (A)	Lower limit	Upper limit
UUT Zero	STANDBY	-8.00E-03 REL	8.00E-03 REL
Full scale (+)	10	9.99670E+00	1.00330E+01
Half scale (+)	5	4.97950E+00	5.02050E+00
Half scale (-)	-5	-5.02050E+00	-4.97950E+00
Full scale (-)	-10	-1.00330E+01	-9.99670E+00

AC current 10 A verification

Verify that the displayed readings are within specified limits.

Use the values in the tables following the steps below to verify the performance of the DMM6500. Actual values depend on the published specifications (see [Example reading limit calculation](#) (on page 2-4)).

To verify the AC current accuracy:

1. Set the TERMINALS switch to **REAR**.
2. Press the **FUNCTION** key, select the **Measure Functions** tab, and select **AC Current**.
3. Press the **HOME** key.
4. Set the range to **10A**.
5. Press the **MENU** key.
6. Under Measure, select **Settings**.
7. Make sure that detector bandwidth is set to **30 Hz**.

NOTE

AC current is specified for the detector bandwidth setting of 3 Hz. 3 Hz measures accurately for input signals from 3 Hz to 10 kHz, with reading rates of ≈ 0.5 readings/s. To improve verification throughput to ≈ 3.3 readings/s, set detector bandwidth to 30 Hz for frequencies of 30 Hz to 10 kHz. To verify frequencies 1 kHz and higher, set the detector bandwidth to 300 Hz for faster ≈ 55 readings/s throughput.

8. Connect the DMM6500 to the calibrator and amplifier as shown in the following figure.

CAUTION

Ensure cabling is designed to conduct 10 A without significant voltage drop. In general, cables for the 10 A range steps should be made of heavy gauge wire and should be as short as practical.

Figure 21: Connections for the 10 A range

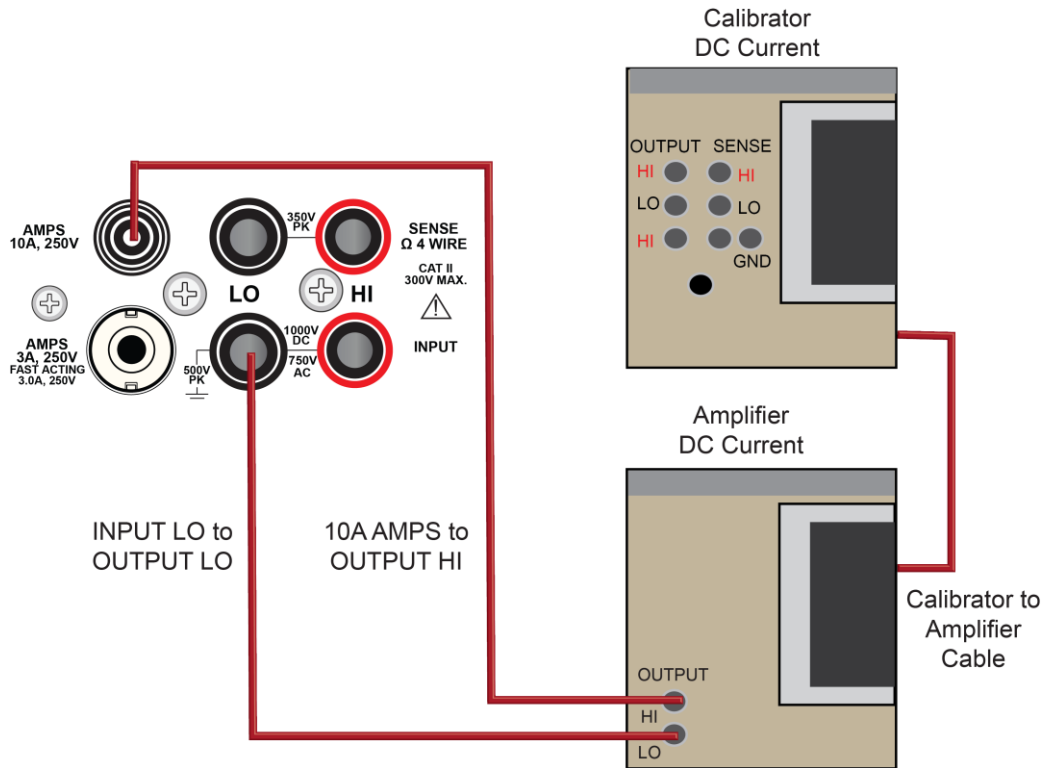

9. Enable the calibrator amplifier and select the **BOOST** key.
10. On the calibrator, set the amplifier range lock to **ON**.
11. Source AC current for each of the frequencies listed in the following table.
12. On the calibrator, select **OPR/STBY** key. Make sure that the front panel displays *OPERATE*.
13. For each setting, allow the calibrator and amplifier to settle properly and verify the reading is within low and high limits.

Verify AC current 10 A range

Description	Verification point	Lower limit	Upper limit
40 Hz	10.000	9.955000E+00	1.004500E+01
1 kHz	10.000	9.955000E+00	1.004500E+01
5 kHz	10.000	9.907000E+00	1.009300E+01

Adjustment

In this section:

Introduction	3-1
Environmental conditions	3-1
Warmup period.....	3-2
Adjustment overview	3-2
Recommended test equipment	3-3
General adjustment considerations.....	3-3
Initial instrument setup	3-4
Remote calibration adjustment procedures.....	3-6
Enable temperature correction.....	3-37
Save calibration and set the adjustment dates.....	3-38
Setting time, adjustment, and verification dates.....	3-38
Adjustment command timing and error checking	3-39
Handling events	3-39

Introduction

Use the procedures in this section to adjust the DMM6500 calibration.

DMM6500 performance is specified for a period of 90 days, 1 year, or 2 years from adjustment. Adjustment should be performed at one of these intervals, depending on your specification requirements.

NOTE

Performance is specified relative to calibration adjustment temperature (T_{cal}). Keithley factory adjustment is performed at $23\text{ }^{\circ}\text{C} \pm 1\text{ }^{\circ}\text{C}$.

WARNING

The information in this section is intended for qualified service personnel only. Do not attempt these procedures unless you are qualified to do so. Some of these procedures may expose you to hazardous voltages, which could cause personal injury or death if contacted. Use appropriate safety precautions when working with hazardous voltages.

Environmental conditions

To make sure accurate results, the environment must meet the following conditions.

Temperature and relative humidity

Conduct the adjustment procedures in a test environment with:

- A stable ambient temperature controlled to vary less than ± 1 °C during the period of adjustment.
- Keithley Instruments recommends a calibration adjustment temperature (T_{cal}) of 23 °C. If a different nominal temperature is used, it should be noted on the calibration report. A relative humidity of less than or equal to 40 percent, unless otherwise noted.
- No direct airflow on the input terminals.

Line power

The DMM6500 requires a line voltage of 100 V to 240 V and a line frequency of 50 Hz, 60 Hz, or 400 Hz.

The instrument must be adjusted within this range.

NOTE

The instrument automatically senses the line frequency at power-up.

Warmup period

Allow the DMM6500 to warm up for at least 30 minutes before conducting the adjustment procedures.

If the instrument has been subjected to temperature extremes (more than 5 °C above or below T_{cal}), allow additional time for the internal temperature of the instrument to stabilize. Typically, allow an additional 30 minutes to stabilize an instrument that is 10 °C outside the specified temperature range.

Also, allow the test equipment to warm up for the time recommended by the manufacturer.

Adjustment overview

DMM6500 adjustment is performed using a remote connection through either an optional GPIB, LAN, or USB interface. The calibration adjustment commands provided in this manual use the Test Script Processor (TSP[®]) command language. There is no front-panel method for full adjustment.

You can use the Keithley Test Script Builder to send you adjustment commands. See "Test Script Builder (TSB)" in the *Model DMM6500 Reference Manual* (DMM6500-901-01).

NOTE

To use GPIB with your DMM6500, you must use the KTTI-GPIB Communication and Digital I/O Accessory.

Recommended test equipment

The following table summarizes the recommended calibration equipment. Specified accuracy of all functions and ranges is dependent on the precision of reference signals used during the adjustment process. To achieve specified performance, adjustment reference uncertainties must be at least four times smaller than the best corresponding DMM6500 one-year accuracy specification for measuring that signal.

Manufacturer	Model	Description	Used for:
Fluke	5720A or 5730A	High Performance Multifunction Calibrator	DCV, 10 A DCI, ACV, ACI, and 10 k Ω resistance
Fluke	5725A	Amplifier	DCI and ACI 10 A ranges
Fluke	8508A	8.5 Digit Reference Multimeter	DCV
Keithley Instruments	3390	Function/Arbitrary Waveform Generator	Frequency
Keithley Instruments	8610 or 8620	4-Wire DMM Shorting Plug	DCV, digitize DCV, and resistance

NOTE

Refer to the manufacturer's specifications to calculate the uncertainty, which varies for each function and range test point.

General adjustment considerations

- DMM6500 DCV performance is sensitive to errors from thermoelectric potentials generated by test cables and connections. Be sure to use high-quality cables and connection techniques. When changing a connection during the adjustment process, be sure to allow time (up to five minutes) for thermal settling. Also allow thermal settling time, typically 60 seconds, when changing the Front/Rear switch position during adjustment.
- Calibration steps are performed on both rear and front inputs as described in sections below. Be sure that the Front/Rear switch is in the proper position before sending adjustment commands.
- The Keithley Models 8610 and 8620 4-wire shorts connect all four terminals electrically, but the layout of the board traces makes DMM6500 adjustment sensitive to their orientation. Note the HI/LO terminal markings and be sure to insert connections in the correct orientation. Note that the DMM6500 rear input terminals are rotated 90° compared to front-panel inputs.
- During adjustment steps using a calibrator reference source, be sure the calibrator reference signal has fully settled before sending adjustment commands to the DMM6500.

WARNING

The front and rear terminals of the instrument are rated for connection to circuits rated Measurement Category II up to 300 V, as described in International Electrotechnical Commission (IEC) Standard IEC 60664. This range must not be exceeded. Do not connect the instrument terminals to CAT III or CAT IV circuits. Connection of the instrument terminals to circuits higher than CAT II can cause damage to the equipment and severe personal injury.

The maximum input voltage between INPUT HI and INPUT LO is 1000 V_{PEAK}. Exceeding this value may result in instrument damage.

The maximum input voltage between INPUT HI and INPUT LO is 1000 V DC and 750 V AC. Exceeding this value may create a shock hazard.

The maximum common-mode voltage (the voltage between INPUT LO and chassis ground) is 500 V_{PEAK}. Exceeding this value may cause a breakdown in insulation that can create a shock hazard.

The information in this section is intended for qualified service personnel only. Do not attempt these procedures unless you are qualified to do so. Some of these procedures may expose you to hazardous voltages, which could cause personal injury or death if contacted. Use appropriate safety precautions when working with hazardous voltages.

Initial instrument setup

Before adjusting calibration, make sure that the instrument is set up:

- To use the rear terminals.
- For remote operation and TSP commands.
- To the correct date and time.

You must also unlock calibration.

Select the correct terminals

On the DMM6500, you must adjust calibration from both the front and rear terminals. You can verify calibration on either the front or rear terminals. To set the instrument to the rear-panel terminals, press the **TERMINALS** switch on the front panel of the instrument.

Select the TSP command set

Calibration adjustment must be performed by remote control using LAN, USB, or optional GPIB interfaces. No front-panel calibration commands are available.

Calibration is only available using TSP commands. See the instructions below to change the command set.

To set the command set from the front panel:

1. Press the **MENU** key.
2. Under System, select **Settings**.
3. For Command Set, select **TSP**.
4. You are prompted to reboot.

To verify which command set is selected from a remote interface:

Send the command:

```
*LANG?
```

To change to the TSP command set from a remote interface:

Send the command:

```
*LANG TSP
```

Reboot the instrument.

Verify instrument date and time

Before adjusting calibration, verify the system date of the DMM6500.

From the front panel:

1. Press the **MENU** key.
2. Under System, select **Settings**. The SYSTEM SETTINGS menu opens.
3. Verify the date and time.
4. If necessary, correct the date and time.

Set up remote connections

NOTE

For detail on remote communications, refer to the *DMM6500 Reference Manual* section "Remote communications interfaces."

Calibration adjustment is performed by connecting reference signals to the DMM6500 and sending a series of adjustment commands using one of the remote interfaces. The adjustment procedure may be done interactively, programmatically, or using a combination of the two.

Interactive: Manually set up and connect each reference signal, then send the appropriate calibration adjustment command.

Programmatic: A computer performs setup of calibrator source instruments and controls appropriate settling delays before automatically sending calibration adjustment commands to the DMM6500. The control program must determine when the adjustment step is complete and check for adjustment errors before continuing to the next step.

The following section describes the DMM6500 adjustment commands that are used for a manual interactive adjustment procedure. Techniques for controlling automated program timing and error checking are described in [Adjustment command timing and error checking](#) (on page 3-39).

Unlock calibration

To start making adjustments, you must unlock it by sending the calibration password:

```
cal.unlock("KI000CAL")
```

NOTE

KI000CAL is the default password. You can change the password. Refer to [cal.password](#) (on page 4-6) for details.

Disable temperature correction

Even though temperature correction does not affect calibration, it must be disabled while calibration is being performed.

```
cal.adjust.step.setup("TC_EN")
cal.adjust.step.execute("TC_EN", 0)
```

Remote calibration adjustment procedures

NOTE

The front-panel display does not show calibration progress or completion.

The following sections provide the preparation and command parameters that you need to complete adjustments to you DMM6500. The preparation sections provide information necessary for making connections and other equipment needed for that adjustment. The command parameter tables are meant to run through in any order allowing you to adjust just the parameters you need. For a complete adjustment, run through these sections in order, making the preparations and running all of the command parameters.

You will send each command parameter twice. The first time you use the setup command, and the second time you will use the execute command. More information on these commands can be found in the [TSP command reference](#) (on page 4-3). The two commands used are:

```
cal.adjust.step.setup
cal.adjust.step.execute
```

Disable temperature correction

Before you start your adjustment, you must turn off temperature correction. Run the following commands to turn off temperature correction.

```
cal.adjust.step.setup("TC_EN")
cal.adjust.step.execute("TC_EN", 0)
```

Front-terminal adjustment with a 4-wire short

The following procedure provides instructions for completing a front-terminal adjustment using a 4-wire short. The following section provides a command parameter table to complete the adjustment.

For this adjustment, you need a:

- Keithley Model 8610 or Model 8620 Low Thermal Shorting Plug.

Prepare your DMM6500 for a front-terminal adjustment with a 4-wire short

To prepare the DMM6500 for a front-terminal adjustment with a 4-wire short:

1. Set the TERMINALS switch to **FRONT**.
2. Install the Keithley Model 8610 or 8620 shorting plug on the front terminals of the DMM6500 as shown in the figure below.

NOTE

The shorting plug terminals must be connected so that HI and LO are correctly aligned. Zero accuracy will be affected if the shorting plug terminals are not aligned correctly.

Figure 22: Connection for a front-panel adjustment with a 4-wire short

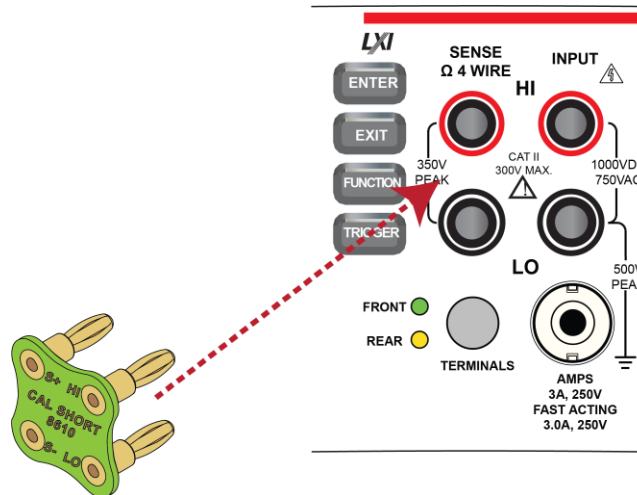

3. Allow to settle for five minutes.

Command parameters for a front-terminal adjustment with a 4-wire short

When calibrating your DMM6500 for a front-terminal adjustment with a 4-wire short, use the following command parameters.

Send each command parameter twice. First, send the parameter using the `setup` command. Second, send the parameter using the `execute` command.

The example code below uses the first command parameter from the table below. Send all command parameters using this command.

```
cal.adjust.step.setup("cal_DCV_100mV_zero_front")
cal.adjust.step.execute("cal_DCV_100mV_zero_front")
```

Command parameters

cal_DCV_100mV_zero_front
cal_DCV_DIGI_100mV_zero
cal_DCV_1V_zero_front
cal_DCV_DIGI_1V_zero
cal_DCV_10V_zero_front
cal_sense_10V_zero_front
cal_DCV_DIGI_10V_zero
cal_DCV_100V_zero_front
cal_DCV_DIGI_100V_zero
cal_DCV_1kV_zero_front
cal_DCV_DIGI_1kV_zero
cal_4W_1ohm_zero_front
cal_2W_10ohm_zero_front
cal_4W_10ohm_zero_front
cal_2W_100ohm_zero_front
cal_4W_100ohm_zero_front
cal_2W_1kohm_zero_front
cal_3W_1kohm_zero_front
cal_3W_1kohm_Hi_zero_front
cal_3W_1kohm_SLO_zero_front
cal_4W_1kohm_zero_front
cal_2W_10kohm_zero_front
cal_3W_10kohm_zero_front
cal_3W_10kohm_SLO_zero_front
cal_4W_10kohm_zero_front
cal_2W_100kohm_zero_front
cal_3W_100kohm_SLO_zero_front
cal_4W_100kohm_zero_front
cal_2W_1Mohm_zero_front
cal_4W_1Mohm_zero_front
cal_2W_HiOhm_zero_front
cal_4W_HiOhm_zero_front
cal_4W_HiOhm_zero_sense
cal_diode_10mA_zero_front
cal_diode_1mA_zero_front
cal_diode_100uA_zero_front
cal_diode_10uA_zero_front
cal_ACV_1V_zero
cal_ACV_10V_zero

Rear-terminal adjustment with a 4-wire short

The following procedure provides instructions for completing a rear-terminal adjustment using a 4-wire short. The following section provides a command parameter table to complete the adjustment.

For this adjustment, you need a:

- Keithley Model 8610 or Model 8620 Low Thermal Shorting Plug

Prepare your DMM6500 for a rear-terminal adjustment with a 4-wire short

To prepare the DMM6500 for rear-terminal adjustment:

- Set the TERMINALS switch to **REAR**.
- Install the Keithley Model 8610 or 8620 shorting plug on the rear terminals of the DMM6500 as shown in the figure below.

CAUTION

The shorting plug terminals must be connected so that HI and LO are correctly aligned. Zero accuracy will be affected if the shorting plug terminals are not aligned correctly.

Figure 23: Connection for a rear-panel adjustment with a 4-wire short

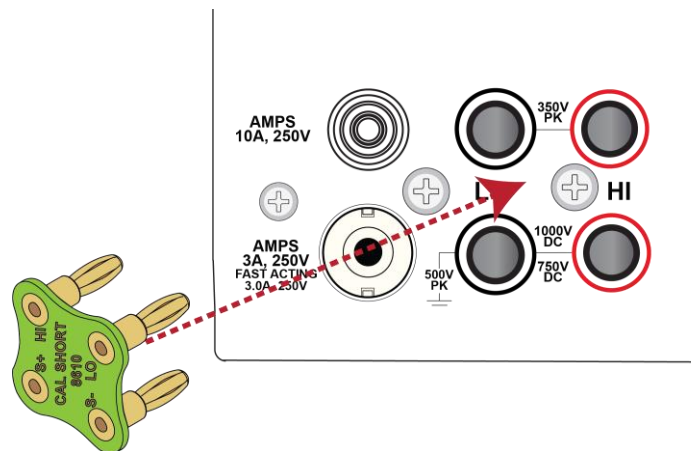

- Allow the DMM6500 to settle for five minutes.

Command parameters for a rear-terminal adjustment with a 4-wire short

When calibrating your DMM6500 for a rear-terminal adjustment with a 4-wire short, use the following command parameters.

Send each command parameter twice. First, send the parameter using the `setup` command. Second, send the parameter using the `execute` command.

The example code below uses the first line of code from the table below. Send all command parameters using this command.

```
cal.adjust.step.setup("cal_DCV_100mV_zero_rear_setup")
cal.adjust.step.execute("cal_DCV_100mV_zero_rear_setup")
```

Command parameters

cal_DCV_100mV_zero_rear
cal_DCV_1V_zero_rear
cal_DCV_10V_zero_rear
cal_sense_10V_zero_rear
cal_DCV_100V_zero_rear
cal_DCV_1kV_zero_rear
cal_4W_1ohm_zero_rear
cal_2W_10ohm_zero_rear
cal_4W_10ohm_zero_rear
cal_2W_100ohm_zero_rear
cal_4W_100ohm_zero_rear
cal_2W_1kohm_zero_rear
cal_3W_1kohm_zero_rear
cal_3W_1kohm_SLO_zero_rear
cal_4W_1kohm_zero_rear
cal_2W_10kohm_zero_rear
cal_3W_10kohm_zero_rear
cal_3W_10kohm_SLO_zero_rear
cal_4W_10kohm_zero_rear
cal_2W_100kohm_zero_rear
cal_3W_100kohm_SLO_zero_rear
cal_4W_100kohm_zero_rear
cal_2W_1Mohm_zero_rear
cal_4W_1Mohm_zero_rear
cal_2W_HiOhm_zero_rear
cal_4W_HiOhm_zero_rear
cal_diode_10mA_zero_rear
cal_diode_1mA_zero_rear
cal_diode_100uA_zero_rear
cal_diode_10uA_zero_rear

Front-terminal adjustment with open circuit inputs

The following procedure provides instructions for completing a front-terminal adjustment with open circuit inputs. The following section provides a command parameter table to complete the adjustment.

Prepare your DMM6500 for a front-terminal adjustment with open circuit inputs

To prepare the DMM6500 for a front-terminal adjustment with open circuit inputs:

1. Set the TERMINALS switch to **FRONT**.
2. Remove all connections from the front terminals of your DMM6500.

Command parameters for a front-terminal adjustment with open circuit inputs

When calibrating your DMM6500 for a front-terminal adjustment with open circuit inputs, use the following command parameters.

Send each command parameter twice. First, send the parameter using the `setup` command. Second, send the parameter using the `execute` command.

The example code below uses the first line of code from the table below. Send all command parameters using this command.

```
cal.adjust.step.setup("cal_DCI_3A_zero_front")
cal.adjust.step.execute("cal_DCI_3A_zero_front")
```

Command parameters

cal_DCI_3A_zero_front
cal_DCI_1A_zero_front
cal_DCI_100mA_zero_front
cal_DCI_10mA_zero_front
cal_DCI_1mA_zero_front
cal_DCI_100uA_zero_front
cal_DCI_10uA_zero_front
cal_DCI_DIGI_3A_zero
cal_DCI_DIGI_1A_zero
cal_DCI_DIGI_100mA_zero
cal_DCI_DIGI_10mA_zero
cal_DCI_DIGI_1mA_zero
cal_DCI_DIGI_100uA_zero
cal_ACI_1A_zero
cal_ACI_3A_zero
cal_4W_HiOhm_7Vref_open
cal_CAP_zero

Rear-terminal adjustment with open circuit inputs

The following procedure provides instructions for completing a rear-terminal adjustment with open circuit inputs. The following section provides a command parameter table to complete the adjustment.

Prepare your DMM6500 for a rear-terminal adjustment with a 4-wire short

To prepare the DMM6500 for rear-terminal adjustment:

1. Set the TERMINALS switch to **REAR**.
2. Remove all connections from the front terminals of your DMM6500.

Command parameters for a rear-terminal adjustment with open circuit inputs

When calibrating your DMM6500 for a rear-terminal adjustment with open circuit inputs, use the following command parameters.

Send each command parameter twice. First, send the parameter using the `setup` command. Second, send the parameter using the `execute` command.

The example code below uses the first line of code from the table below. Send all command parameters using this command.

```
cal.adjust.step.setup("cal_DCI_10A_zero_rear")
cal.adjust.step.execute("cal_DCI_10A_zero_rear")
```

Command parameters

cal_DCI_10A_zero_rear
cal_DCI_DIGI_10A_zero_rear
cal_DCI_3A_zero_rear
cal_DCI_1A_zero_rear
cal_DCI_100mA_zero_rear
cal_DCI_10mA_zero_rear
cal_DCI_1mA_zero_rear
cal_DCI_100uA_zero_rear
cal_DCI_10uA_zero_rear

Resistance adjustment

The following procedure provides instructions for completing a resistance adjustment. The following section provides a command parameter table to complete the adjustment.

For this adjustment, you need a:

- Fluke 5720 calibrator

Prepare your DMM6500 for a resistance adjustment

To prepare the DMM6500 for a front-terminal adjustment:

1. Set the TERMINALS switch to **FRONT**.
2. Connect the DMM6500 to the calibrator as shown in the following figure.

Figure 24: Connection for a resistance accuracy adjustment

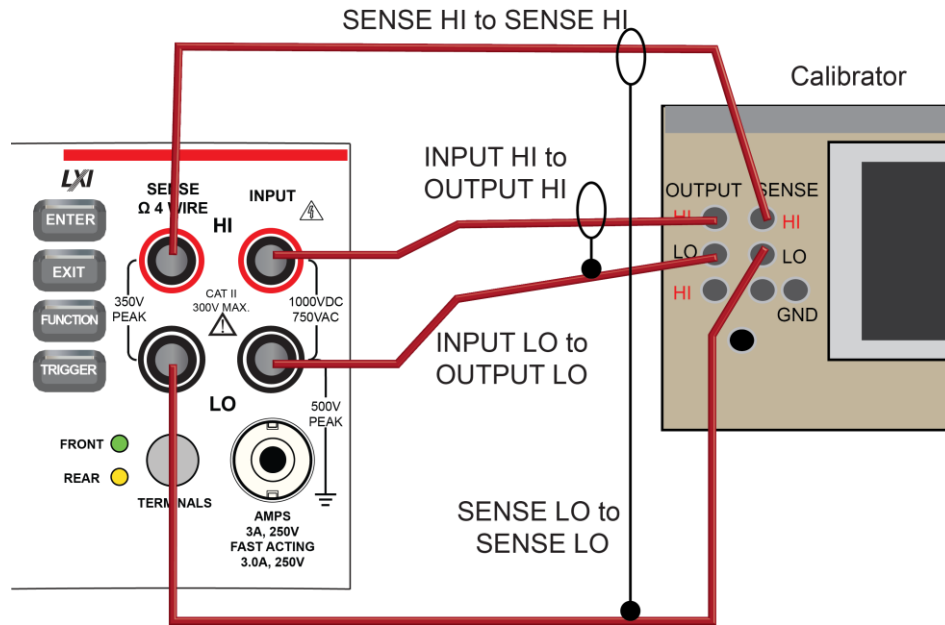

3. Allow the instruments and cables to settle for five minutes.
4. On the calibrator, enable the **OPR** key and the **EX SNS** key.
5. Make sure that the OPERATE display and EX SNS keys are illuminated.

Command parameters for a resistance adjustment

When calibrating your DMM6500 for a resistance adjustment, use the following command parameters.

Send each command parameter twice. First, send the parameter using the `setup` command. Second, send the parameter using the `execute` command along with the calibrator stimulus value.

The example code below uses the first line of code from the table below. Send all command parameters using this command.

```
cal.adjust.step.setup("cal_4W_10ohm_fs")
cal.adjust.step.execute("cal_4W_10ohm_fs", <calibrator stimulus value>)
```

CAUTION

Since the temperature sensor is adjusted here, you are advised to perform all resistance adjustment steps in the same calibration session. If only a partial calibration is performed and the original `T_cal` differs from the new `T_cal`, the ranges that are not adjusted may be less accurate. Completing an adjustment for all of the resistance steps will remove these errors.

NOTE

You must send the `cal_TS7` first.

Command parameters	Calibrator function	Calibrator range	Calibrator value	Calibrator stimulus value
cal_TS7	n/a	n/a	n/a	n/a
cal_4W_10ohm_fs	4-wire Ω	10	10	actual from calibrator
cal_4W_10ohm_OCOMP_fs	4-wire Ω	10	10	actual from calibrator
cal_4W_100ohm_fs	4-wire Ω	100	100	actual from calibrator
cal_4W_100ohm_OCOMP_fs	4-wire Ω	100	100	actual from calibrator
cal_4W_1kohm_fs	4-wire Ω	1000	1000	actual from calibrator
cal_4W_1kohm_OCOMP_fs	4-wire Ω	1000	1000	actual from calibrator
cal_source_1mA_1V	4-wire Ω	1000	1000	actual from calibrator
cal_4W_10kohm_fs	4-wire Ω	10000	10000	actual from calibrator
cal_4W_10kohm_OCOMP_fs	4-wire Ω	10000	10000	actual from calibrator
cal_source_100uA_1V	4-wire Ω	100000	100000	actual from calibrator
cal_4W_100kohm_fs	4-wire Ω	100000	100000	actual from calibrator
cal_source_10uA_1V	4-wire Ω	100000	100000	actual from calibrator
cal_4W_1Mohm_fs	4-wire Ω	1000000	1000000	actual from calibrator
cal_source_1uA_1V	4-wire Ω	1000000	1000000	actual from calibrator
cal_4W_HiOhm_halfV_10Meg	4-wire Ω	10000000	10000000	actual from calibrator
cal_user_10Meg_value	4-wire Ω	10000000	10000000	actual from calibrator

DC voltage adjustment

The following procedure provides instructions for completing a front-terminal adjustment for DC voltage accuracy. The following section provides a command parameter table to complete the adjustment.

For this adjustment, you need a:

- Fluke 5720 calibrator

Prepare your DMM6500 for a DC voltage adjustment

To prepare the DMM6500 for a DC voltage adjustment:

1. Connect a cable between the calibrator and the DMM6500 as shown in the figure below.

Figure 25: Connection for a DC voltage accuracy adjustment

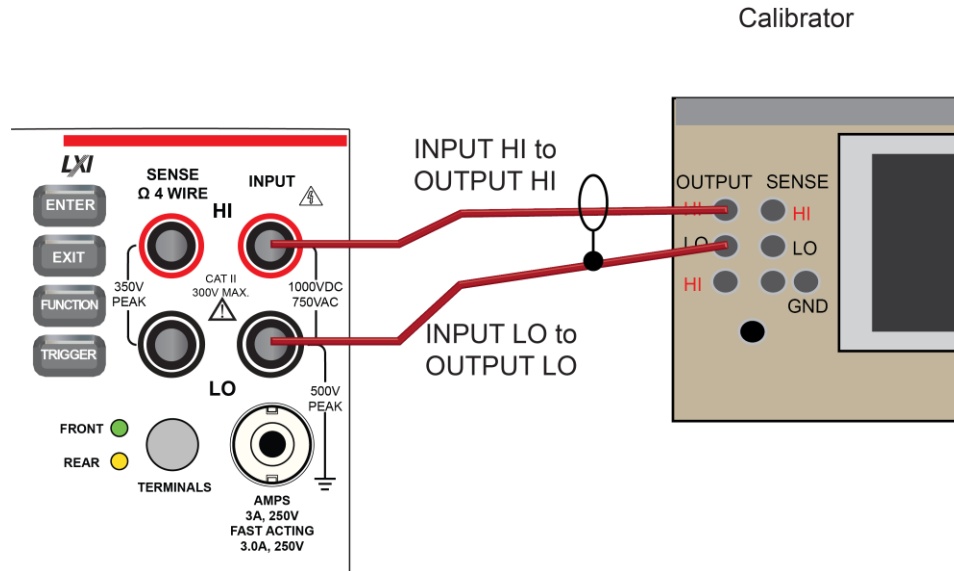

2. Allow the DMM6500 to settle for five minutes.

Command parameters for a DC voltage adjustment

When calibrating your DMM6500 for a DC voltage adjustment, use the following command parameters.

Send each command parameter twice. First, send the parameter using the `setup` command. Second, send the parameter using the `execute` command.

The example code below uses the first line of code from the table below. Send all command parameters using this command.

```
cal.adjust.step.setup("cal_DCV_DIGI_1kV_fs_pos")
cal.adjust.step.execute("cal_DCV_DIGI_1kV_fs_pos")
```

Command parameters	Calibrator function	Calibrator range	Calibrator value
cal_DCV_DIGI_1kV_fs_pos	DC voltage	1100	1000
cal_DCV_DIGI_1kV_fs_neg	DC voltage	1100	-1000
cal_DCV_100V_fs_pos	DC voltage	220	100
cal_DCV_DIGI_100V_fs_pos	DC voltage	220	100
cal_DCV_100V_fs_neg	DC voltage	220	-100
cal_DCV_DIGI_100V_fs_neg	DC voltage	220	-100
cal_DCV_10V_fs_pos	DC voltage	22	10
cal_DCV_DIGI_10V_fs_pos	DC voltage	22	10
cal_DCV_10V_fs_neg	DC voltage	22	-10
cal_DCV_DIGI_10V_fs_neg	DC voltage	22	-10
cal_DCV_DIGI_1V_fs_pos	DC voltage	2.2	1
cal_DCV_DIGI_1V_fs_neg	DC voltage	2.2	-1
cal_DCV_DIGI_100mV_fs_pos	DC voltage	0.22	0.1
cal_DCV_DIGI_100mV_fs_neg	DC voltage	0.22	-0.1

DC current adjustment

The following procedure provides instructions for completing a front-terminal adjustment for DC current accuracy. The following section provides a command parameter table to complete the adjustment.

For this adjustment, you need a:

- Fluke 5720 calibrator
- Fluke 8508A Reference DMM

Prepare your DMM6500 for a DC current adjustment

To prepare the DMM6500 for DC current adjustment:

Connect the Model DMM6500 to the calibrator as shown in the following figure.

Figure 26: Connection for DC current

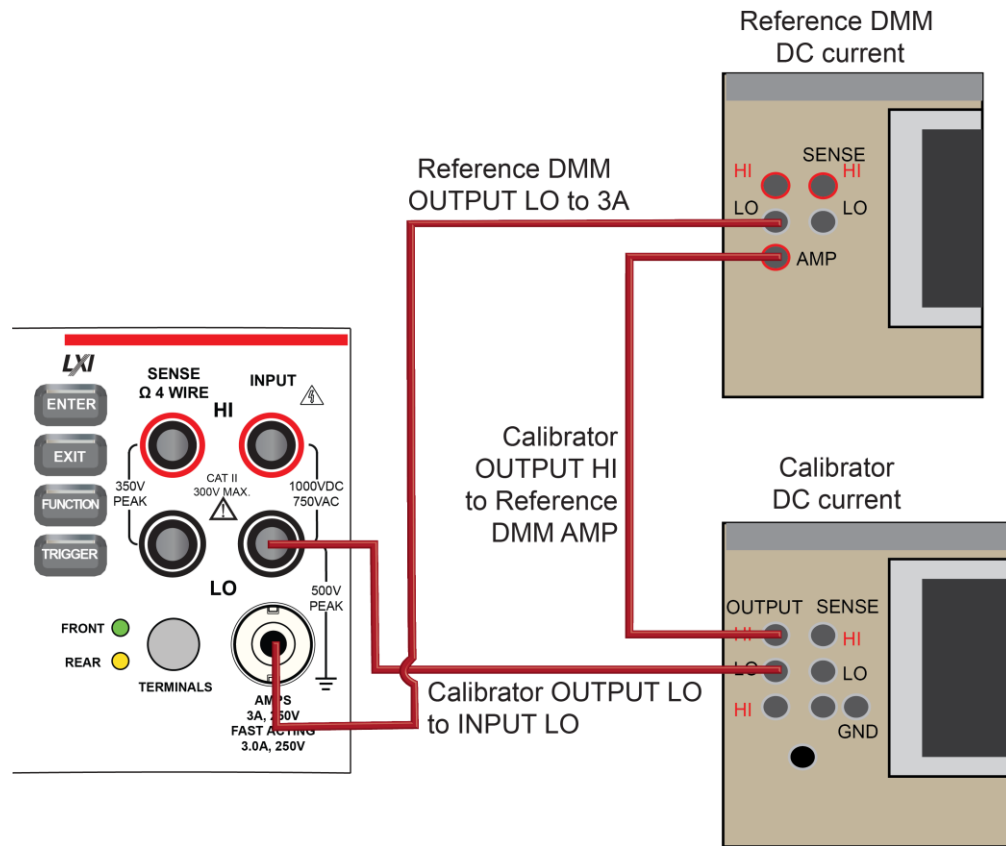

Command parameters for a DC current adjustment

When calibrating your DMM6500 for a DC current adjustment, use the following command parameters.

Send each command parameter twice. First, send the parameter using the `setup` command. Second, send the parameter using the `execute` command along with the calibrator stimulus value.

The example code below uses the first line of code from the table below. Send all command parameters using this command.

```
cal.adjust.step.setup("cal_DCI_10uA_fs_pos")
cal.adjust.step.execute("cal_DCI_10uA_fs_pos", <calibrator stimulus value>)
```

NOTE

You must send the `cal_TS6` first.

Command parameters	Calibrator function	Calibrator range	Calibrator value	Calibrator stimulus value*	Reference DMM DC current range
<code>cal_TS6</code>	n/a	n/a	n/a	n/a	n/a
10 µA range (+) full scale nominal					
<code>cal_DCI_10uA_fs_pos</code>	DC current	0.00022	0.00001	8508A Reading	10 µA
<code>cal_DCI_DIGI_10uA_fs_pos</code>	DC current	0.00022	0.00001	8508A Reading	10 µA
10 µA range (-) full scale nominal					
<code>cal_DCI_10uA_fs_neg</code>	DC current	0.00022	-0.00001	8508A Reading	10 µA
<code>cal_DCI_DIGI_10uA_fs_neg</code>	DC current	0.00022	-0.00001	8508A Reading	10 µA
100 µA range (+) full scale nominal					
<code>cal_DCI_100uA_fs_pos</code>	DC current	0.00022	0.0001	8508A Reading	100 µA
<code>cal_DCI_DIGI_100uA_fs_pos</code>	DC current	0.00022	0.0001	8508A Reading	100 µA
100 µA range (-) full scale nominal					
<code>cal_DCI_100uA_fs_neg</code>	DC current	0.00022	-0.0001	8508A Reading	100 µA
<code>cal_DCI_DIGI_100uA_fs_neg</code>	DC current	0.00022	-0.0001	8508A Reading	100 µA

*Characterized step measured by the Fluke 8508A

Command parameters	Calibrator function	Calibrator range	Calibrator value	Calibrator stimulus value*	Calibrator stimulus value
--------------------	---------------------	------------------	------------------	----------------------------	---------------------------

1 mA range (+) full scale nominal

cal_DCI_1mA_fs_pos	DC current	0.0022	0.001	8508A Reading	1 mA
cal_DCI_DIGI_1mA_fs_pos	DC current	0.0022	0.001	8508A Reading	1 mA

1 mA range (-) full scale nominal

cal_DCI_1mA_fs_neg	DC current	0.0022	-0.001	8508A Reading	1 mA
cal_DCI_DIGI_1mA_fs_neg	DC current	0.0022	-0.001	8508A Reading	1 mA

10 mA range (+) full scale nominal

cal_DCI_10mA_fs_pos	DC current	0.022	0.01	8508A Reading	10 mA
cal_DCI_DIGI_10mA_fs_pos	DC current	0.022	0.01	8508A Reading	10 mA

10 mA range (-) full scale nominal

cal_DCI_10mA_fs_neg	DC current	0.022	-0.01	8508A Reading	10 mA
cal_DCI_DIGI_10mA_fs_neg	DC current	0.022	-0.01	8508A Reading	10 mA

*Characterized step measured by the Fluke 8508A

Command parameters	Calibrator function	Calibrator range	Calibrator value	Calibrator stimulus value	Reference DMM DC current range
--------------------	---------------------	------------------	------------------	---------------------------	--------------------------------

cal_DCI_100mA_fs_pos	DC current	0.22	0.1	n/a	20 A
cal_DCI_DIGI_100mA_fs_pos	DC current	0.22	0.1	n/a	20 A
cal_DCI_100mA_fs_neg	DC current	0.22	-0.1	n/a	20 A
cal_DCI_DIGI_100mA_fs_neg	DC current	0.22	-0.1	n/a	20 A
cal_TS5	DC current	n/a	n/a	n/a	20 A
cal_DCI_1A_fs_pos	DC current	2.2	1	n/a	20 A
cal_DCI_DIGI_1A_fs_pos	DC current	2.2	1	n/a	20 A
cal_DCI_1A_fs_neg	DC current	2.2	-1	n/a	20 A
cal_DCI_DIGI_1A_fs_neg	DC current	2.2	-1	n/a	20 A
cal_DCI_DIGI_3A_fs_pos	DC current	2.2	2	n/a	20 A
cal_DCI_DIGI_3A_fs_neg	DC current	2.2	-2	n/a	20 A

DC current 10 A range adjustment

The following procedure provides instructions for completing a rear-terminal DC current adjustment for the 10 A range. The following section provides a command parameter table to complete the adjustment.

For this adjustment, you need a:

- Fluke 5720 calibrator
- 10 A cable

Prepare your DMM6500 for a DC current 10 A range adjustment

To prepare the DMM6500 for an DC current adjustment for the 10 A range:

Connect the DMM6500 to the calibrator as shown in the following figure using 10 A cables.

Figure 27: Connection for a 10 A range adjustment

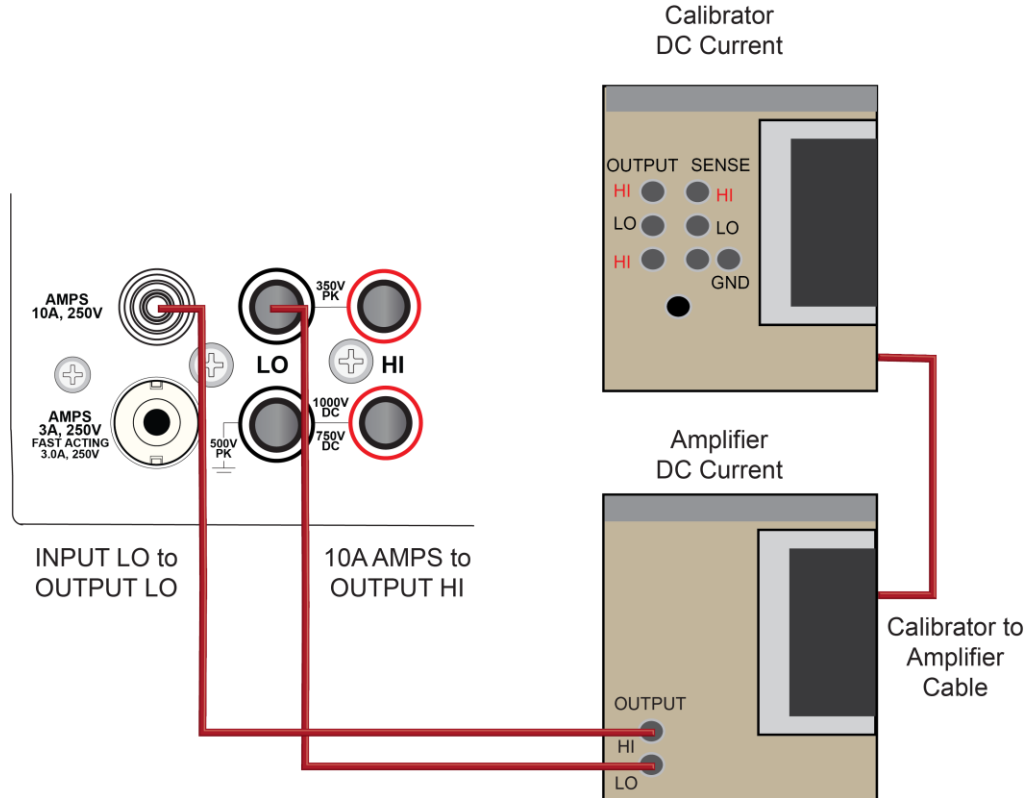

Command parameters for a DC current 10 A range adjustment

When calibrating your DMM6500 for a DC current 10 A range adjustment, use the following command parameters. Connect a 10 A cable for this adjustment.

Send each command parameter twice. First, send the parameter using the `setup` command. Second, send the parameter using the `execute` command.

The example code below uses the first line of code from the table below. Send all command parameters using this command.

```
cal.adjust.step.setup("cal_DCI_10A_fs_pos")
cal.adjust.step.execute("cal_DCI_10A_fs_pos")
```

Command parameters	Calibrator function	Calibrator range	Calibrator value
cal_DCI_10A_fs_pos	DC current	2.2	2
cal_DCI_DIGI_10A_fs_pos	DC current	2.2	2
cal_DCI_10A_fs_neg	DC current	2.2	-2
cal_DCI_DIGI_10A_fs_neg	DC current	2.2	-2

AC voltage adjustment

The following procedure provides instructions for completing a front-terminal adjustment for AC voltage. The following section provides a command parameter table to complete the adjustment.

For this adjustment, you need a:

- Fluke 5720 calibrator
- Keithley Model 3390 function generator

Prepare your DMM6500 for an AC voltage adjustment

To prepare to run AC adjustments:

1. Set the TERMINALS switch to **FRONT**.
2. Connect a cable between the calibrator and the DMM6500 as shown in the figure below.

Figure 28: Connection for an AC voltage adjustment

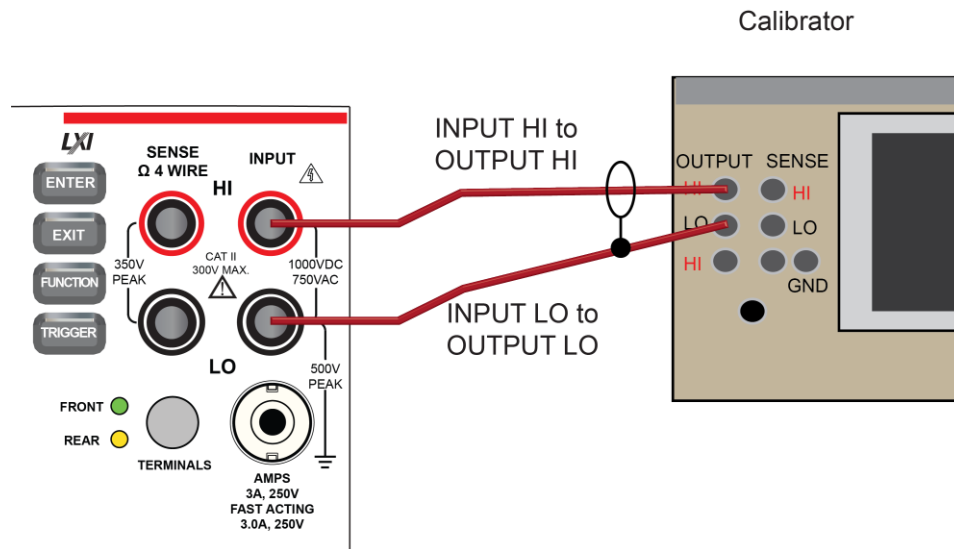

3. Allow the instrument and cables to settle for 30 seconds.
4. On the calibrator, source **10 mV 1.0 kHz** and allow the calibrator and DMM6500 to settle properly.
5. Enable the **OPR** key.
6. Ensure that the **OPERATE** display is illuminated.
7. Allow the calibrator and cable to settle properly.

Command parameters for an AC voltage adjustment

When calibrating your DMM6500 for an AC voltage adjustment, use the following command parameters.

Send each command parameter twice. First, send the parameter using the `setup` command. Second, send the parameter using the `execute` command.

The example code below uses the first line of code from the table below. Send all command parameters using this command.

```
cal.adjust.step.setup("cal_ACV_100mV_1kHz_1pct")
cal.adjust.step.execute("cal_ACV_100mV_1kHz_1pct")
```

Command parameter	Calibrator function	Calibrator range	Calibrator value	Calibrator frequency
cal_ACV_100mV_1kHz_1pct	AC voltage	0.0022	0.001	1 kHz
cal_ACV_100mV_10Hz_fs	AC voltage	0.22	0.1	10 Hz
cal_ACV_100mV_1kHz_fs	AC voltage	0.22	0.1	1 kHz
cal_ACV_100mV_50kHz_fs	AC voltage	0.22	0.1	50 kHz
cal_ACV_100mV_100kHz_fs	AC voltage	0.22	0.1	100 kHz
cal_ACV_100mV_200kHz_fs	AC voltage	0.22	0.1	200 kHz
cal_ACV_100mV_300kHz_fs	AC voltage	0.22	0.1	300 kHz
cal_ACV_1V_1kHz_1pct	AC voltage	0.022	0.01	1 kHz
cal_ACV_1V_10Hz_fs	AC voltage	2.2	1	10 Hz
cal_ACV_1V_1kHz_fs	AC voltage	2.2	1	1 kHz
cal_ACV_1V_50kHz_fs	AC voltage	2.2	1	50 kHz
cal_ACV_1V_100kHz_fs	AC voltage	2.2	1	100 kHz
cal_ACV_1V_200kHz_fs	AC voltage	2.2	1	200 kHz
cal_ACV_1V_300kHz_fs	AC voltage	2.2	1	300 kHz
cal_ACV_10V_1kHz_1pct	AC voltage	0.22	0.1	1 kHz
cal_ACV_10V_10Hz_fs	AC voltage	22	10	10 Hz
cal_ACV_10V_1kHz_fs	AC voltage	22	10	1 kHz
cal_ACV_10V_50kHz_fs	AC voltage	22	10	50 kHz
cal_ACV_10V_100kHz_fs	AC voltage	22	10	100 kHz
cal_ACV_10V_200kHz_fs	AC voltage	22	10	200 kHz
cal_ACV_10V_300kHz_fs	AC voltage	22	10	300 kHz
cal_ACV_100V_10Hz_1pct	AC voltage	2.2	1	10 Hz
cal_ACV_100V_1kHz_1pct	AC voltage	2.2	1	1 kHz
cal_ACV_100V_50kHz_1pct	AC voltage	2.2	1	50 kHz
cal_ACV_100V_100kHz_1pct	AC voltage	2.2	1	100 kHz
cal_ACV_100V_200kHz_1pct	AC voltage	2.2	1	200 kHz
cal_ACV_100V_300kHz_1pct	AC voltage	2.2	1	300 kHz
cal_ACV_100V_1kHz_fs	AC voltage	220	100	1 kHz
cal_ACV_700V_10Hz_1pct	AC voltage	22	7	10 Hz
cal_ACV_700V_1kHz_1pct	AC voltage	22	7	1 kHz
cal_ACV_700V_50kHz_1pct	AC voltage	22	7	50 kHz

Command parameter	Calibrator function	Calibrator range	Calibrator value	Calibrator frequency
cal_ACV_700V_100kHz_1pct	AC voltage	22	7	100 kHz
cal_ACV_700V_200kHz_1pct	AC voltage	22	7	200 kHz
cal_ACV_700V_300kHz_1pct	AC voltage	22	7	300 kHz
cal_ACV_700V_1kHz_fs	AC voltage	1100	750	1 kHz

AC current adjustment

The following procedure provides instructions for completing a front-terminal adjustment for AC current. The following section provides a command parameter table to complete the adjustment.

For this adjustment, you need a:

- Fluke 5720 calibrator

Prepare your DMM6500 for an AC current adjustment

To prepare the DMM6500 for an AC current adjustment:

Connect the Model DMM6500 to the calibrator as shown in the following figure.

Figure 29: Connection for AC current

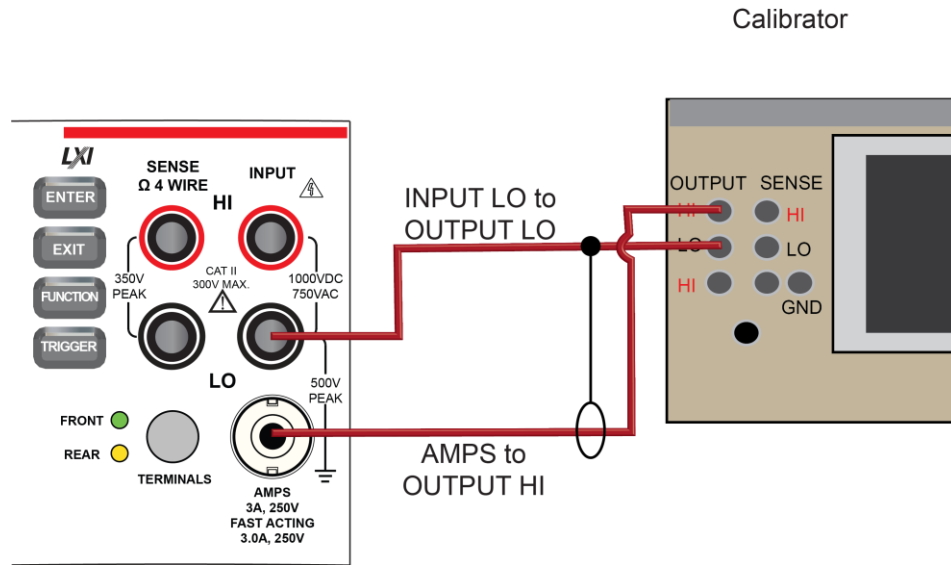

Command parameters for an AC current adjustment

When calibrating your DMM6500 for an AC current adjustment, use the following command parameters.

Send each command parameter twice. First, send the parameter using the `setup` command. Second, send the parameter using the `execute` command.

The example code below uses the first line of code from the table below. Send all command parameters using this command.

```
cal.adjust.step.setup("cal_ACI_100uA_1kHz_tenth")
cal.adjust.step.execute("cal_ACI_100uA_1kHz_tenth")
```

Command parameters	Calibrator function	Calibrator range	Calibrator value	Calibrator frequency
cal_ACI_100uA_1kHz_tenth	AC current	0.00022	0.00001	1 kHz
cal_ACI_100uA_1kHz_fs	AC current	0.00022	0.0001	1 kHz
cal_ACI_1mA_1kHz_tenth	AC current	0.00022	0.0001	1 kHz
cal_ACI_1mA_1kHz_fs	AC current	0.0022	0.001	1 kHz
cal_ACI_10mA_1kHz_tenth	AC current	0.0022	0.001	1 kHz
cal_ACI_10mA_10Hz_fs	AC current	0.022	0.01	10 Hz
cal_ACI_10mA_10kHz_fs	AC current	0.022	0.01	10 kHz
cal_ACI_10mA_1kHz_fs	AC current	0.022	0.01	1 kHz
cal_ACI_100mA_1kHz_tenth	AC current	0.022	0.01	1 kHz
cal_ACI_100mA_1kHz_fs	AC current	0.22	0.1	1 kHz
cal_ACI_100mA_10Hz_fs	AC current	0.22	0.1	10 Hz
cal_ACI_200mA_1kHz_fs	AC current	0.22	0.2	1 kHz
cal_ACI_200mA_10kHz_fs	AC current	0.22	0.2	10 kHz
cal_ACI_1A_1kHz_tenth	AC current	0.22	0.1	1 kHz
cal_ACI_1A_10Hz_fs	AC current	2.2	1	10 Hz
cal_ACI_1A_1kHz_fs	AC current	2.2	1	1 kHz
cal_ACI_3A_1kHz_tenth	AC current	2.2	0.3	1 kHz
cal_ACI_3A_1kHz_fs	AC current	2.2	2	1 kHz

AC current 10 A range adjustment

The following procedure provides instructions for completing a front-terminal adjustment AC current in the 10 A range. For this adjustment, you need a Fluke 5720 calibrator. The following section provides a command parameter table to complete the adjustment.

For this adjustment, you need a:

- Fluke 5720 calibrator
- 10 A cable

Prepare your DMM6500 for an AC current 10 A range adjustment

To prepare the DMM6500 for an AC current adjustment in the 10 A range:

Connect the DMM6500 to the calibrator as shown in the following figure using 10 A cables.

Figure 30: Connection for a 10 A range adjustment

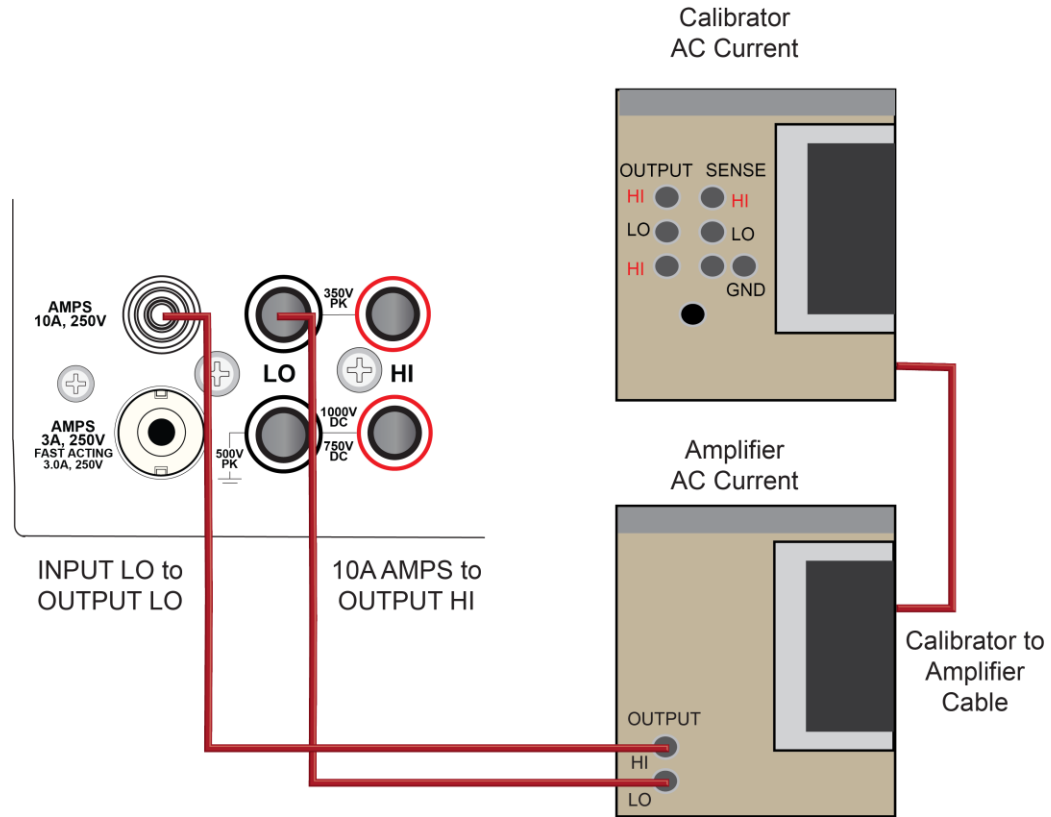

Command parameters for an AC current 10 A range adjustment

When calibrating your DMM6500 for an AC current 10 A range adjustment, use the following command parameters.

Send each command parameter twice. First, send the parameter using the `setup` command. Second, send the parameter using the `execute` command.

The example code below uses the first line of code from the table below. Send all command parameters using this command.

```
cal.adjust.step.setup("cal_ACI_10A_400Hz_tenth")
cal.adjust.step.execute("cal_ACI_10A_400Hz_tenth")
```

Command parameters	Calibrator function	Calibrator range	Calibrator value	Calibrator frequency
cal_ACI_10A_400Hz_tenth	AC current	2.1	1	400 Hz
cal_ACI_10A_400Hz_fs	AC current	11	7	400 Hz
cal_ACI_10A_5kHz_fs	AC current	11	7	5 kHz
cal_ACI_10A_400Hz_2A	AC current	2.2	2	400 Hz
cal_ACI_10A_10Hz_2A	AC current	2.2	2	10 Hz

Frequency adjustment

The following procedure provides instructions for completing a front-terminal adjustment for frequency. The following section provides a command parameter table to complete the adjustment.

For this adjustment, you need a:

- 50 Ω coaxial cable
- Keithley Model 3390 function generator

Prepare your DMM6500 for a frequency adjustment

To prepare the DMM6500 for a frequency adjustment:

1. Connect the Keithley Instruments Model 3390 function generator to the DMM6500 INPUT HI and LO terminals as shown in the following figure.
2. Use the BNC to banana adapter at the UUT connection.

Figure 31: Connection for a frequency adjustment

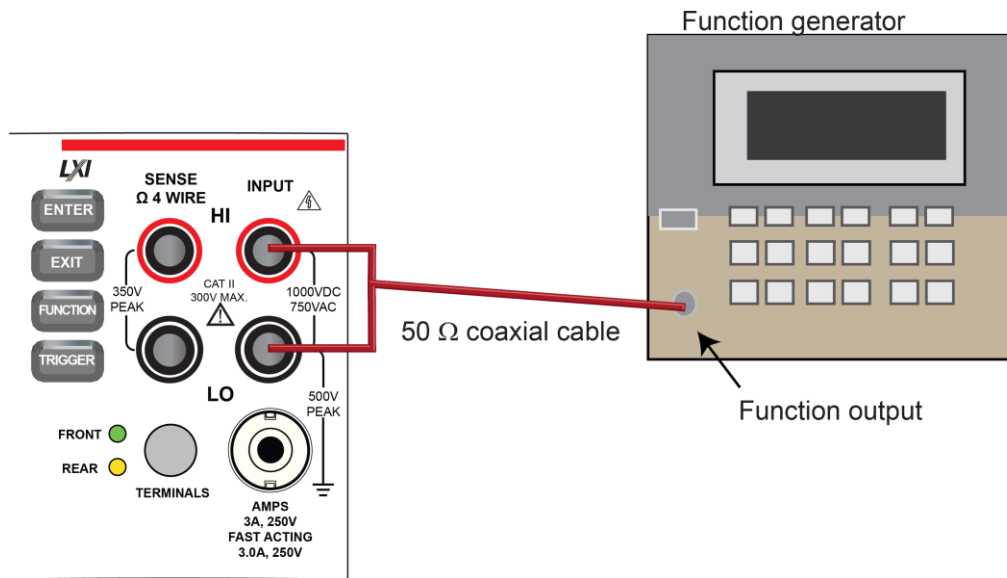

3. Set the function generator output impedance to high, amplitude of 5 V_{RMS}, waveform to square wave.
4. Enable output.

Command parameters for a frequency adjustment

When calibrating your DMM6500 for a frequency adjustment, use the following command parameters.

Send each command parameter twice. First, send the parameter using the `setup` command. Second, send the parameter using the `execute` command.

The example code below uses the first line of code from the table below. Send all command parameters using this command.

```
cal.adjust.step.setup("cal_FREQ_1kHz")
cal.adjust.step.execute("cal_FREQ_1kHz")
```

Command parameter	Calibrator function	Calibrator range	Calibrator value	Calibrator frequency
cal_FREQ_1kHz	Frequency	22	10	1 kHz

Complete list of calibration commands

To make your adjustment procedure easier, you can copy and paste the code examples below into the Keithley Test Script Builder (TSB software). The commands can be copied and pasted two lines at a time.

NOTE

All parameters in italics must be replaced with the specified value. For example,

`cal.adjust.step.execute("cal_4W_10ohm_fs",
10ohm_value_read_from_calibrator)` must have the italics replaced with the calibrator value.

```
--Use front-terminal 4-wire short setup
cal.adjust.step.setup("cal_DCV_100mV_zero_front")
cal.adjust.step.execute("cal_DCV_100mV_zero_front")
--Use front-terminal 4-wire short setup
cal.adjust.step.setup("cal_DCV_DIGI_100mV_zero")
cal.adjust.step.execute("cal_DCV_DIGI_100mV_zero")
--Use front-terminal 4-wire short setup
cal.adjust.step.setup("cal_DCV_1V_zero_front")
cal.adjust.step.execute("cal_DCV_1V_zero_front")
--Use front-terminal 4-wire short setup
cal.adjust.step.setup("cal_DCV_DIGI_1V_zero")
cal.adjust.step.execute("cal_DCV_DIGI_1V_zero")
--Use front-terminal 4-wire short setup
cal.adjust.step.setup("cal_DCV_10V_zero_front")
cal.adjust.step.execute("cal_DCV_10V_zero_front")
--Use front-terminal 4-wire short setup
cal.adjust.step.setup("cal_sense_10V_zero_front")
cal.adjust.step.execute("cal_sense_10V_zero_front")
--Use front-terminal 4-wire short setup
cal.adjust.step.setup("cal_DCV_DIGI_10V_zero")
cal.adjust.step.execute("cal_DCV_DIGI_10V_zero")
--Use front-terminal 4-wire short setup
cal.adjust.step.setup("cal_DCV_100V_zero_front")
cal.adjust.step.execute("cal_DCV_100V_zero_front")
--Use front-terminal 4-wire short setup
cal.adjust.step.setup("cal_DCV_DIGI_100V_zero")
cal.adjust.step.execute("cal_DCV_DIGI_100V_zero")
--Use front-terminal 4-wire short setup
cal.adjust.step.setup("cal_DCV_1kV_zero_front")
cal.adjust.step.execute("cal_DCV_1kV_zero_front")
--Use front-terminal 4-wire short setup
cal.adjust.step.setup("cal_DCV_DIGI_1kV_zero")
cal.adjust.step.execute("cal_DCV_DIGI_1kV_zero")
--Use front-terminal 4-wire short setup
cal.adjust.step.setup("cal_4W_1ohm_zero_front")
cal.adjust.step.execute("cal_4W_1ohm_zero_front")
--Use front-terminal 4-wire short setup
cal.adjust.step.setup("cal_2W_10ohm_zero_front")
cal.adjust.step.execute("cal_2W_10ohm_zero_front")
--Use front-terminal 4-wire short setup
cal.adjust.step.setup("cal_4W_10ohm_zero_front")
cal.adjust.step.execute("cal_4W_10ohm_zero_front")
--Use front-terminal 4-wire short setup
cal.adjust.step.setup("cal_2W_100ohm_zero_front")
```

```
cal.adjust.step.execute("cal_2W_100ohm_zero_front")
--Use front-terminal 4-wire short setup
cal.adjust.step.setup("cal_4W_100ohm_zero_front")
cal.adjust.step.execute("cal_4W_100ohm_zero_front")
--Use front-terminal 4-wire short setup
cal.adjust.step.setup("cal_2W_1kohm_zero_front")
cal.adjust.step.execute("cal_2W_1kohm_zero_front")
--Use front-terminal 4-wire short setup
cal.adjust.step.setup("cal_3W_1kohm_zero_front")
cal.adjust.step.execute("cal_3W_1kohm_zero_front")
--Use front-terminal 4-wire short setup
cal.adjust.step.setup("cal_3W_1kohm_Hi_zero_front")
cal.adjust.step.execute("cal_3W_1kohm_Hi_zero_front")
--Use front-terminal 4-wire short setup
cal.adjust.step.setup("cal_3W_1kohm_SLO_zero_front")
cal.adjust.step.execute("cal_3W_1kohm_SLO_zero_front")
--Use front-terminal 4-wire short setup
cal.adjust.step.setup("cal_4W_1kohm_zero_front")
cal.adjust.step.execute("cal_4W_1kohm_zero_front")
--Use front-terminal 4-wire short setup
cal.adjust.step.setup("cal_2W_10kohm_zero_front")
cal.adjust.step.execute("cal_2W_10kohm_zero_front")
--Use front-terminal 4-wire short setup
cal.adjust.step.setup("cal_3W_10kohm_zero_front")
cal.adjust.step.execute("cal_3W_10kohm_zero_front")
--Use front-terminal 4-wire short setup
cal.adjust.step.setup("cal_3W_10kohm_SLO_zero_front")
cal.adjust.step.execute("cal_3W_10kohm_SLO_zero_front")
--Use front-terminal 4-wire short setup
cal.adjust.step.setup("cal_4W_10kohm_zero_front")
cal.adjust.step.execute("cal_4W_10kohm_zero_front")
--Use front-terminal 4-wire short setup
cal.adjust.step.setup("cal_2W_100kohm_zero_front")
cal.adjust.step.execute("cal_2W_100kohm_zero_front")
--Use front-terminal 4-wire short setup
cal.adjust.step.setup("cal_3W_100kohm_SLO_zero_front")
cal.adjust.step.execute("cal_3W_100kohm_SLO_zero_front")
--Use front-terminal 4-wire short setup
cal.adjust.step.setup("cal_4W_100kohm_zero_front")
cal.adjust.step.execute("cal_4W_100kohm_zero_front")
--Use front-terminal 4-wire short setup
cal.adjust.step.setup("cal_2W_1Mohm_zero_front")
cal.adjust.step.execute("cal_2W_1Mohm_zero_front")
--Use front-terminal 4-wire short setup
cal.adjust.step.setup("cal_4W_1Mohm_zero_front")
cal.adjust.step.execute("cal_4W_1Mohm_zero_front")
--Use front-terminal 4-wire short setup
cal.adjust.step.setup("cal_2W_HiOhm_zero_front")
cal.adjust.step.execute("cal_2W_HiOhm_zero_front")
--Use front-terminal 4-wire short setup
cal.adjust.step.setup("cal_4W_HiOhm_zero_front")
cal.adjust.step.execute("cal_4W_HiOhm_zero_front")
--Use front-terminal 4-wire short setup
cal.adjust.step.setup("cal_4W_HiOhm_zero_sense")
cal.adjust.step.execute("cal_4W_HiOhm_zero_sense")
--Use front-terminal 4-wire short setup
cal.adjust.step.setup("cal_diode_10mA_zero_front")
```

```
cal.adjust.step.execute("cal_diode_10mA_zero_front")
--Use front-terminal 4-wire short setup
cal.adjust.step.setup("cal_diode_1mA_zero_front")
cal.adjust.step.execute("cal_diode_1mA_zero_front")
--Use front-terminal 4-wire short setup
cal.adjust.step.setup("cal_diode_100uA_zero_front")
cal.adjust.step.execute("cal_diode_100uA_zero_front")
--Use front-terminal 4-wire short setup
cal.adjust.step.setup("cal_diode_10uA_zero_front")
cal.adjust.step.execute("cal_diode_10uA_zero_front")
--Use front-terminal 4-wire short setup
cal.adjust.step.setup("cal_ACV_1V_zero")
cal.adjust.step.execute("cal_ACV_1V_zero")
--Use front-terminal 4-wire short setup
cal.adjust.step.setup("cal_ACV_10V_zero")
cal.adjust.step.execute("cal_ACV_10V_zero")
--Use rear-terminal 4-wire short setup
cal.adjust.step.setup("cal_DCV_100mV_zero_rear")
cal.adjust.step.execute("cal_DCV_100mV_zero_rear")
--Use rear-terminal 4-wire short setup
cal.adjust.step.setup("cal_DCV_100mV_zero_rear")
cal.adjust.step.execute("cal_DCV_100mV_zero_rear")
--Use rear-terminal 4-wire short setup
cal.adjust.step.setup("cal_DCV_1V_zero_rear")
cal.adjust.step.execute("cal_DCV_1V_zero_rear")
--Use rear-terminal 4-wire short setup
cal.adjust.step.setup("cal_DCV_10V_zero_rear")
cal.adjust.step.execute("cal_DCV_10V_zero_rear")
--Use rear-terminal 4-wire short setup
cal.adjust.step.setup("cal_sense_10V_zero_rear")
cal.adjust.step.execute("cal_sense_10V_zero_rear")
--Use rear-terminal 4-wire short setup
cal.adjust.step.setup("cal_DCV_100V_zero_rear")
cal.adjust.step.execute("cal_DCV_100V_zero_rear")
--Use rear-terminal 4-wire short setup
cal.adjust.step.setup("cal_DCV_1kV_zero_rear")
cal.adjust.step.execute("cal_DCV_1kV_zero_rear")
--Use rear-terminal 4-wire short setup
cal.adjust.step.setup("cal_4W_1ohm_zero_rear")
cal.adjust.step.execute("cal_4W_1ohm_zero_rear")
--Use rear-terminal 4-wire short setup
cal.adjust.step.setup("cal_2W_10ohm_zero_rear")
cal.adjust.step.execute("cal_2W_10ohm_zero_rear")
--Use rear-terminal 4-wire short setup
cal.adjust.step.setup("cal_4W_10ohm_zero_rear")
cal.adjust.step.execute("cal_4W_10ohm_zero_rear")
--Use rear-terminal 4-wire short setup
cal.adjust.step.setup("cal_2W_100ohm_zero_rear")
cal.adjust.step.execute("cal_2W_100ohm_zero_rear")
--Use rear-terminal 4-wire short setup
cal.adjust.step.setup("cal_4W_100ohm_zero_rear")
cal.adjust.step.execute("cal_4W_100ohm_zero_rear")
--Use rear-terminal 4-wire short setup
cal.adjust.step.setup("cal_2W_1kohm_zero_rear")
cal.adjust.step.execute("cal_2W_1kohm_zero_rear")
--Use rear-terminal 4-wire short setup
cal.adjust.step.setup("cal_3W_1kohm_zero_rear")
```

```
cal.adjust.step.execute("cal_3W_1kohm_zero_rear")
--Use rear-terminal 4-wire short setup
cal.adjust.step.setup("cal_3W_1kohm_SLO_zero_rear")
cal.adjust.step.execute("cal_3W_1kohm_SLO_zero_rear")
--Use rear-terminal 4-wire short setup
cal.adjust.step.setup("cal_4W_1kohm_zero_rear")
cal.adjust.step.execute("cal_4W_1kohm_zero_rear")
--Use rear-terminal 4-wire short setup
cal.adjust.step.setup("cal_2W_10kohm_zero_rear")
cal.adjust.step.execute("cal_2W_10kohm_zero_rear")
--Use rear-terminal 4-wire short setup
cal.adjust.step.setup("cal_3W_10kohm_zero_rear")
cal.adjust.step.execute("cal_3W_10kohm_zero_rear")
--Use rear-terminal 4-wire short setup
cal.adjust.step.setup("cal_3W_10kohm_SLO_zero_rear")
cal.adjust.step.execute("cal_3W_10kohm_SLO_zero_rear")
--Use rear-terminal 4-wire short setup
cal.adjust.step.setup("cal_4W_10kohm_zero_rear")
cal.adjust.step.execute("cal_4W_10kohm_zero_rear")
--Use rear-terminal 4-wire short setup
cal.adjust.step.setup("cal_2W_100kohm_zero_rear")
cal.adjust.step.execute("cal_2W_100kohm_zero_rear")
--Use rear-terminal 4-wire short setup
cal.adjust.step.setup("cal_3W_100kohm_SLO_zero_rear")
cal.adjust.step.execute("cal_3W_100kohm_SLO_zero_rear")
--Use rear-terminal 4-wire short setup
cal.adjust.step.setup("cal_4W_100kohm_zero_rear")
cal.adjust.step.execute("cal_4W_100kohm_zero_rear")
--Use rear-terminal 4-wire short setup
cal.adjust.step.setup("cal_2W_1Mohm_zero_rear")
cal.adjust.step.execute("cal_2W_1Mohm_zero_rear")
--Use rear-terminal 4-wire short setup
cal.adjust.step.setup("cal_4W_1Mohm_zero_rear")
cal.adjust.step.execute("cal_4W_1Mohm_zero_rear")
--Use rear-terminal 4-wire short setup
cal.adjust.step.setup("cal_2W_HiOhm_zero_rear")
cal.adjust.step.execute("cal_2W_HiOhm_zero_rear")
--Use rear-terminal 4-wire short setup
cal.adjust.step.setup("cal_4W_HiOhm_zero_rear")
cal.adjust.step.execute("cal_4W_HiOhm_zero_rear")
--Use rear-terminal 4-wire short setup
cal.adjust.step.setup("cal_diode_10mA_zero_rear")
cal.adjust.step.execute("cal_diode_10mA_zero_rear")
--Use rear-terminal 4-wire short setup
cal.adjust.step.setup("cal_diode_1mA_zero_rear")
cal.adjust.step.execute("cal_diode_1mA_zero_rear")
--Use rear-terminal 4-wire short setup
cal.adjust.step.setup("cal_diode_100uA_zero_rear")
cal.adjust.step.execute("cal_diode_100uA_zero_rear")
--Use rear-terminal 4-wire short setup
cal.adjust.step.setup("cal_diode_10uA_zero_rear")
cal.adjust.step.execute("cal_diode_10uA_zero_rear")
--Use front-terminal 4-wire open circuit setup
cal.adjust.step.setup("cal_DCI_3A_zero_front")
cal.adjust.step.execute("cal_DCI_3A_zero_front")
--Use front-terminal 4-wire open circuit setup
cal.adjust.step.setup("cal_DCI_1A_zero_front")
```

```
cal.adjust.step.execute("cal_DCI_1A_zero_front")
--Use front-terminal 4-wire open circuit setup
cal.adjust.step.setup("cal_DCI_100mA_zero_front")
cal.adjust.step.execute("cal_DCI_100mA_zero_front")
--Use front-terminal 4-wire open circuit setup
cal.adjust.step.setup("cal_DCI_10mA_zero_front")
cal.adjust.step.execute("cal_DCI_10mA_zero_front")
--Use front-terminal 4-wire open circuit setup
cal.adjust.step.setup("cal_DCI_1mA_zero_front")
cal.adjust.step.execute("cal_DCI_1mA_zero_front")
--Use front-terminal 4-wire open circuit setup
cal.adjust.step.setup("cal_DCI_100uA_zero_front")
cal.adjust.step.execute("cal_DCI_100uA_zero_front")
--Use front-terminal 4-wire open circuit setup
cal.adjust.step.setup("cal_DCI_10uA_zero_front")
cal.adjust.step.execute("cal_DCI_10uA_zero_front")
--Use front-terminal 4-wire open circuit setup
cal.adjust.step.setup("cal_DCI_DIGI_3A_zero")
cal.adjust.step.execute("cal_DCI_DIGI_3A_zero")
--Use front-terminal 4-wire open circuit setup
cal.adjust.step.setup("cal_DCI_DIGI_1A_zero")
cal.adjust.step.execute("cal_DCI_DIGI_1A_zero")
--Use front-terminal 4-wire open circuit setup
cal.adjust.step.setup("cal_DCI_DIGI_100mA_zero")
cal.adjust.step.execute("cal_DCI_DIGI_100mA_zero")
--Use front-terminal 4-wire open circuit setup
cal.adjust.step.setup("cal_DCI_DIGI_10mA_zero")
cal.adjust.step.execute("cal_DCI_DIGI_10mA_zero")
--Use front-terminal 4-wire open circuit setup
cal.adjust.step.setup("cal_DCI_DIGI_1mA_zero")
cal.adjust.step.execute("cal_DCI_DIGI_1mA_zero")
--Use front-terminal 4-wire open circuit setup
cal.adjust.step.setup("cal_DCI_DIGI_100uA_zero")
cal.adjust.step.execute("cal_DCI_DIGI_100uA_zero")
--Use front-terminal 4-wire open circuit setup
cal.adjust.step.setup("cal_ACI_1A_zero")
cal.adjust.step.execute("cal_ACI_1A_zero")
--Use front-terminal 4-wire open circuit setup
cal.adjust.step.setup("cal_ACI_3A_zero")
cal.adjust.step.execute("cal_ACI_3A_zero")
--Use front-terminal 4-wire open circuit setup
cal.adjust.step.setup("cal_4W_HiOhm_7Vref_open")
cal.adjust.step.execute("cal_4W_HiOhm_7Vref_open")
--Use front-terminal 4-wire open circuit setup
cal.adjust.step.setup("cal_CAP_zero")
cal.adjust.step.execute("cal_CAP_zero")
--Use rear-terminal 4-wire open circuit setup
cal.adjust.step.setup("cal_DCI_10A_zero_rear")
cal.adjust.step.execute("cal_DCI_10A_zero_rear")
--Use rear-terminal 4-wire open circuit setup
cal.adjust.step.setup("cal_DCI_DIGI_10A_zero_rear")
cal.adjust.step.execute("cal_DCI_DIGI_10A_zero_rear")
--Use rear-terminal 4-wire open circuit setup
cal.adjust.step.setup("cal_DCI_3A_zero_rear")
cal.adjust.step.execute("cal_DCI_3A_zero_rear")
--Use rear-terminal 4-wire open circuit setup
cal.adjust.step.setup("cal_DCI_1A_zero_rear")
```

```
cal.adjust.step.execute("cal_DCI_1A_zero_rear")
--Use rear-terminal 4-wire open circuit setup
cal.adjust.step.setup("cal_DCI_100mA_zero_rear")
cal.adjust.step.execute("cal_DCI_100mA_zero_rear")
--Use rear-terminal 4-wire open circuit setup
cal.adjust.step.setup("cal_DCI_10mA_zero_rear")
cal.adjust.step.execute("cal_DCI_10mA_zero_rear")
--Use rear-terminal 4-wire open circuit setup
cal.adjust.step.setup("cal_DCI_1mA_zero_rear")
cal.adjust.step.execute("cal_DCI_1mA_zero_rear")
--Use rear-terminal 4-wire open circuit setup
cal.adjust.step.setup("cal_DCI_100uA_zero_rear")
cal.adjust.step.execute("cal_DCI_100uA_zero_rear")
--Use rear-terminal 4-wire open circuit setup
cal.adjust.step.setup("cal_DCI_10uA_zero_rear")
cal.adjust.step.execute("cal_DCI_10uA_zero_rear")
--Use resistance setup
cal.adjust.step.setup("cal_TS7")
cal.adjust.step.execute("cal_TS7")
--Use resistance setup
cal.adjust.step.setup("cal_4W_10ohm_fs")
cal.adjust.step.execute("cal_4W_10ohm_fs", 10ohm_value_read_from_calibrator)
--Use resistance setup
cal.adjust.step.setup("cal_4W_10ohm_OCOMP_fs")
cal.adjust.step.execute("cal_4W_10ohm_OCOMP_fs", 10ohm_value_read_from_calibrator)
--Use resistance setup
cal.adjust.step.setup("cal_4W_100ohm_fs")
cal.adjust.step.execute("cal_4W_100ohm_fs", 100ohm_value_read_from_calibrator)
--Use resistance setup
cal.adjust.step.setup("cal_4W_100ohm_OCOMP_fs")
cal.adjust.step.execute("cal_4W_100ohm_OCOMP_fs", 100ohm_value_read_from_calibrator)
--Use resistance setup
cal.adjust.step.setup("cal_4W_1kohm_fs")
cal.adjust.step.execute("cal_4W_1kohm_fs", 1kohm_value_read_from_calibrator)
--Use resistance setup
cal.adjust.step.setup("cal_4W_1kohm_OCOMP_fs")
cal.adjust.step.execute("cal_4W_1kohm_OCOMP_fs", 1kohm_value_read_from_calibrator)
--Use resistance setup
cal.adjust.step.setup("cal_source_1mA_1V")
cal.adjust.step.execute("cal_source_1mA_1V", 1kohm_value_read_from_calibrator)
--Use resistance setup
cal.adjust.step.setup("cal_4W_10kohm_fs")
cal.adjust.step.execute("cal_4W_10kohm_fs", 10kohm_value_read_from_calibrator)
--Use resistance setup
cal.adjust.step.setup("cal_4W_10kohm_OCOMP_fs")
cal.adjust.step.execute("cal_4W_10kohm_OCOMP_fs",
    10kohm_value_read_from_calibrator)
--Use resistance setup
cal.adjust.step.setup("cal_source_100uA_1V")
cal.adjust.step.execute("cal_source_100uA_1V", 10kohm_value_read_from_calibrator)
--Use resistance setup
cal.adjust.step.setup("cal_4W_100kohm_fs")
cal.adjust.step.execute("cal_4W_100kohm_fs", 100kohm_value_read_from_calibrator)
--Use resistance setup
cal.adjust.step.setup("cal_source_10uA_1V")
cal.adjust.step.execute("cal_source_10uA_1V", 100kohm_value_read_from_calibrator)
--Use resistance setup
```



```
cal.adjust.step.setup("cal_4W_1Mohm_fs")
cal.adjust.step.execute("cal_4W_1Mohm_fs", 1Mohm_value_read_from_calibrator)
--Use resistance setup
cal.adjust.step.setup("cal_source_1uA_1V")
cal.adjust.step.execute("cal_source_1uA_1V", 1Mohm_value_read_from_calibrator)
--Use resistance setup
cal.adjust.step.setup("cal_4W_HiOhm_halfV_10Meg")
cal.adjust.step.execute("cal_4W_HiOhm_halfV_10Meg", 10Mohm_value_read_from_calibrator)
--Use resistance setup
cal.adjust.step.setup("cal_user_10Meg_value")
cal.adjust.step.execute("cal_user_10Meg_value", 10Mohm_value_read_from_calibrator)
--Use DC voltage setup
cal.adjust.step.setup("cal_DCV_DIGI_1kV_fs_pos")
cal.adjust.step.setup("cal_DCV_DIGI_1kV_fs_pos")
--Use DC voltage setup
cal.adjust.step.setup("cal_DCV_DIGI_1kV_fs_neg")
cal.adjust.step.setup("cal_DCV_DIGI_1kV_fs_neg")
--Use DC voltage setup
cal.adjust.step.setup("cal_DCV_100V_fs_pos")
cal.adjust.step.setup("cal_DCV_100V_fs_pos")
--Use DC voltage setup
cal.adjust.step.setup("cal_DCV_DIGI_100V_fs_pos")
cal.adjust.step.setup("cal_DCV_DIGI_100V_fs_pos")
--Use DC voltage setup
cal.adjust.step.setup("cal_DCV_100V_fs_neg")
cal.adjust.step.setup("cal_DCV_100V_fs_neg")
--Use DC voltage setup
cal.adjust.step.setup("cal_DCV_DIGI_100V_fs_neg")
cal.adjust.step.setup("cal_DCV_DIGI_100V_fs_neg")
--Use DC voltage setup
cal.adjust.step.setup("cal_DCV_10V_fs_pos")
cal.adjust.step.setup("cal_DCV_10V_fs_pos")
--Use DC voltage setup
cal.adjust.step.setup("cal_DCV_DIGI_10V_fs_pos")
cal.adjust.step.setup("cal_DCV_DIGI_10V_fs_pos")
--Use DC voltage setup
cal.adjust.step.setup("cal_DCV_10V_fs_neg")
cal.adjust.step.setup("cal_DCV_10V_fs_neg")
--Use DC voltage setup
cal.adjust.step.setup("cal_DCV_DIGI_10V_fs_neg")
cal.adjust.step.setup("cal_DCV_DIGI_10V_fs_neg")
--Use DC voltage setup
cal.adjust.step.setup("cal_DCV_DIGI_1V_fs_pos")
cal.adjust.step.setup("cal_DCV_DIGI_1V_fs_pos")
--Use DC voltage setup
cal.adjust.step.setup("cal_DCV_DIGI_1V_fs_neg")
cal.adjust.step.setup("cal_DCV_DIGI_1V_fs_neg")
--Use DC voltage setup
cal.adjust.step.setup("cal_DCV_DIGI_100mV_fs_pos")
cal.adjust.step.setup("cal_DCV_DIGI_100mV_fs_pos")
--Use DC voltage setup
cal.adjust.step.setup("cal_DCV_DIGI_100mV_fs_neg")
cal.adjust.step.setup("cal_DCV_DIGI_100mV_fs_neg")
--Use DC current setup
cal.adjust.step.setup("cal_DCI_10uA_fs_pos")
cal.adjust.step.execute("cal_DCI_10uA_fs_pos", value_read_from_8508A)
--Use DC current setup
```

```
cal.adjust.step.setup("cal_DCI_DIGI_10uA_fs_pos")
cal.adjust.step.execute("cal_DCI_DIGI_10uA_fs_pos",value_read_from_ 8508A)
--Use DC current setup
cal.adjust.step.setup("cal_DCI_10uA_fs_neg")
cal.adjust.step.execute("cal_DCI_10uA_fs_neg",value_read_from_ 8508A)
--Use DC current setup
cal.adjust.step.setup("cal_DCI_DIGI_10uA_fs_neg")
cal.adjust.step.execute("cal_DCI_DIGI_10uA_fs_neg",value_read_from_ 8508A)
--Use DC current setup
cal.adjust.step.setup("cal_DCI_100uA_fs_pos")
cal.adjust.step.execute("cal_DCI_100uA_fs_pos",value_read_from_ 8508A)
--Use DC current setup
cal.adjust.step.setup("cal_DCI_DIGI_100uA_fs_pos")
cal.adjust.step.execute("cal_DCI_DIGI_100uA_fs_pos",value_read_from_ 8508A)
--Use DC current setup
cal.adjust.step.setup("cal_DCI_100uA_fs_neg")
cal.adjust.step.execute("cal_DCI_100uA_fs_neg",value_read_from_ 8508A)
--Use DC current setup
cal.adjust.step.setup("cal_DCI_DIGI_100uA_fs_neg")
cal.adjust.step.execute("cal_DCI_DIGI_100uA_fs_neg",value_read_from_ 8508A)
--Use DC current setup
cal.adjust.step.setup("cal_DCI_1mA_fs_pos")
cal.adjust.step.execute("cal_DCI_1mA_fs_pos",value_read_from_ 8508A)
--Use DC current setup
cal.adjust.step.setup("cal_DCI_DIGI_1mA_fs_pos")
cal.adjust.step.execute("cal_DCI_DIGI_1mA_fs_pos",value_read_from_ 8508A)
--Use DC current setup
cal.adjust.step.setup("cal_DCI_1mA_fs_neg")
cal.adjust.step.execute("cal_DCI_1mA_fs_neg",value_read_from_ 8508A)
--Use DC current setup
cal.adjust.step.setup("cal_DCI_DIGI_1mA_fs_neg")
cal.adjust.step.execute("cal_DCI_DIGI_1mA_fs_neg",value_read_from_ 8508A)
--Use DC current setup
cal.adjust.step.setup("cal_DCI_10mA_fs_pos")
cal.adjust.step.execute("cal_DCI_10mA_fs_pos",value_read_from_ 8508A)
--Use DC current setup
cal.adjust.step.setup("cal_DCI_DIGI_10mA_fs_pos")
cal.adjust.step.execute("cal_DCI_DIGI_10mA_fs_pos",value_read_from_ 8508A)
--Use DC current setup
cal.adjust.step.setup("cal_DCI_10mA_fs_neg")
cal.adjust.step.execute("cal_DCI_10mA_fs_neg",value_read_from_ 8508A)
--Use DC current setup
cal.adjust.step.setup("cal_DCI_DIGI_10mA_fs_neg")
cal.adjust.step.execute("cal_DCI_DIGI_10mA_fs_neg",value_read_from_ 8508A)
--Use DC current setup
cal.adjust.step.setup("cal_DCI_100mA_fs_pos")
cal.adjust.step.execute("cal_DCI_100mA_fs_pos")
--Use DC current setup
cal.adjust.step.setup("cal_DCI_DIGI_100mA_fs_pos")
cal.adjust.step.execute("cal_DCI_DIGI_100mA_fs_pos")
--Use DC current setup
cal.adjust.step.setup("cal_DCI_100mA_fs_neg")
cal.adjust.step.execute("cal_DCI_100mA_fs_neg")
--Use DC current setup
cal.adjust.step.setup("cal_DCI_DIGI_100mA_fs_neg")
cal.adjust.step.execute("cal_DCI_DIGI_100mA_fs_neg")
--Use DC current setup
```

```
cal.adjust.step.setup("cal_TS5")
cal.adjust.step.execute("cal_TS5")
--Use DC current setup
cal.adjust.step.setup("cal_DCI_1A_fs_pos")
cal.adjust.step.execute("cal_DCI_1A_fs_pos")
--Use DC current setup
cal.adjust.step.setup("cal_DCI_DIGI_1A_fs_pos")
cal.adjust.step.execute("cal_DCI_DIGI_1A_fs_pos")
--Use DC current setup
cal.adjust.step.setup("cal_DCI_1A_fs_neg")
cal.adjust.step.execute("cal_DCI_1A_fs_neg")
--Use DC current setup
cal.adjust.step.setup("cal_DCI_DIGI_1A_fs_neg")
cal.adjust.step.execute("cal_DCI_DIGI_1A_fs_neg")
--Use DC current setup
cal.adjust.step.setup("cal_DCI_DIGI_3A_fs_pos")
cal.adjust.step.execute("cal_DCI_DIGI_3A_fs_pos")
--Use DC current setup
cal.adjust.step.setup("cal_DCI_DIGI_3A_fs_neg")
cal.adjust.step.execute("cal_DCI_DIGI_3A_fs_neg")
--Use DC current 10 A setup
cal.adjust.step.setup("cal_DCI_10A_fs_pos")
cal.adjust.step.execute("cal_DCI_10A_fs_pos")
--Use DC current 10 A setup
cal.adjust.step.setup("cal_DCI_DIGI_10A_fs_pos")
cal.adjust.step.execute("cal_DCI_DIGI_10A_fs_pos")
--Use DC current 10 A setup
cal.adjust.step.setup("cal_DCI_10A_fs_neg")
cal.adjust.step.execute("cal_DCI_10A_fs_neg")
--Use DC current 10 A setup
cal.adjust.step.setup("cal_DCI_DIGI_10A_fs_neg")
cal.adjust.step.execute("cal_DCI_DIGI_10A_fs_neg")
--Use AC voltage setup
cal.adjust.step.setup("cal_ACV_100mV_1kHz_1pct")
cal.adjust.step.execute("cal_ACV_100mV_1kHz_1pct")
--Use AC voltage setup
cal.adjust.step.setup("cal_ACV_100mV_10Hz_fs")
cal.adjust.step.execute("cal_ACV_100mV_10Hz_fs")
--Use AC voltage setup
cal.adjust.step.setup("cal_ACV_100mV_1kHz_fs")
cal.adjust.step.execute("cal_ACV_100mV_1kHz_fs")
--Use AC voltage setup
cal.adjust.step.setup("cal_ACV_100mV_50kHz_fs")
cal.adjust.step.execute("cal_ACV_100mV_50kHz_fs")
--Use AC voltage setup
cal.adjust.step.setup("cal_ACV_100mV_100kHz_fs")
cal.adjust.step.execute("cal_ACV_100mV_100kHz_fs")
--Use AC voltage setup
cal.adjust.step.setup("cal_ACV_100mV_200kHz_fs")
cal.adjust.step.execute("cal_ACV_100mV_200kHz_fs")
--Use AC voltage setup
cal.adjust.step.setup("cal_ACV_100mV_300kHz_fs")
cal.adjust.step.execute("cal_ACV_100mV_300kHz_fs")
--Use AC voltage setup
cal.adjust.step.setup("cal_ACV_1V_1kHz_1pct")
cal.adjust.step.execute("cal_ACV_1V_1kHz_1pct")
--Use AC voltage setup
```

```
cal.adjust.step.setup("cal_ACV_1V_10Hz_fs")
cal.adjust.step.execute("cal_ACV_1V_10Hz_fs")
--Use AC voltage setup
cal.adjust.step.setup("cal_ACV_1V_1kHz_fs")
cal.adjust.step.execute("cal_ACV_1V_1kHz_fs")
--Use AC voltage setup
cal.adjust.step.setup("cal_ACV_1V_50kHz_fs")
cal.adjust.step.execute("cal_ACV_1V_50kHz_fs")
--Use AC voltage setup
cal.adjust.step.setup("cal_ACV_1V_100kHz_fs")
cal.adjust.step.execute("cal_ACV_1V_100kHz_fs")
--Use AC voltage setup
cal.adjust.step.setup("cal_ACV_1V_200kHz_fs")
cal.adjust.step.execute("cal_ACV_1V_200kHz_fs")
--Use AC voltage setup
cal.adjust.step.setup("cal_ACV_1V_300kHz_fs")
cal.adjust.step.execute("cal_ACV_1V_300kHz_fs")
--Use AC voltage setup
cal.adjust.step.setup("cal_ACV_10V_1kHz_1pct")
cal.adjust.step.execute("cal_ACV_10V_1kHz_1pct")
--Use AC voltage setup
cal.adjust.step.setup("cal_ACV_10V_10Hz_fs")
cal.adjust.step.execute("cal_ACV_10V_10Hz_fs")
--Use AC voltage setup
cal.adjust.step.setup("cal_ACV_10V_1kHz_fs")
cal.adjust.step.execute("cal_ACV_10V_1kHz_fs")
--Use AC voltage setup
cal.adjust.step.setup("cal_ACV_10V_50kHz_fs")
cal.adjust.step.execute("cal_ACV_10V_50kHz_fs")
--Use AC voltage setup
cal.adjust.step.setup("cal_ACV_10V_100kHz_fs")
cal.adjust.step.execute("cal_ACV_10V_100kHz_fs")
--Use AC voltage setup
cal.adjust.step.setup("cal_ACV_10V_200kHz_fs")
cal.adjust.step.execute("cal_ACV_10V_200kHz_fs")
--Use AC voltage setup
cal.adjust.step.setup("cal_ACV_10V_300kHz_fs")
cal.adjust.step.execute("cal_ACV_10V_300kHz_fs")
--Use AC voltage setup
cal.adjust.step.setup("cal_ACV_100V_10Hz_1pct")
cal.adjust.step.execute("cal_ACV_100V_10Hz_1pct")
--Use AC voltage setup
cal.adjust.step.setup("cal_ACV_100V_1kHz_1pct")
cal.adjust.step.execute("cal_ACV_100V_1kHz_1pct")
--Use AC voltage setup
cal.adjust.step.setup("cal_ACV_100V_50kHz_1pct")
cal.adjust.step.execute("cal_ACV_100V_50kHz_1pct")
--Use AC voltage setup
cal.adjust.step.setup("cal_ACV_100V_100kHz_1pct")
cal.adjust.step.execute("cal_ACV_100V_100kHz_1pct")
--Use AC voltage setup
cal.adjust.step.setup("cal_ACV_100V_200kHz_1pct")
cal.adjust.step.execute("cal_ACV_100V_200kHz_1pct")
--Use AC voltage setup
cal.adjust.step.setup("cal_ACV_100V_300kHz_1pct")
cal.adjust.step.execute("cal_ACV_100V_300kHz_1pct")
--Use AC voltage setup
```

```
cal.adjust.step.setup("cal_ACV_100V_1kHz_fs")
cal.adjust.step.execute("cal_ACV_100V_1kHz_fs")
--Use AC voltage setup
cal.adjust.step.setup("cal_ACV_700V_10Hz_1pct")
cal.adjust.step.execute("cal_ACV_700V_10Hz_1pct")
--Use AC voltage setup
cal.adjust.step.setup("cal_ACV_700V_1kHz_1pct")
cal.adjust.step.execute("cal_ACV_700V_1kHz_1pct")
--Use AC voltage setup
cal.adjust.step.setup("cal_ACV_700V_50kHz_1pct")
cal.adjust.step.execute("cal_ACV_700V_50kHz_1pct")
--Use AC voltage setup
cal.adjust.step.setup("cal_ACV_700V_100kHz_1pct")
cal.adjust.step.execute("cal_ACV_700V_100kHz_1pct")
--Use AC voltage setup
cal.adjust.step.setup("cal_ACV_700V_200kHz_1pct")
cal.adjust.step.execute("cal_ACV_700V_200kHz_1pct")
--Use AC voltage setup
cal.adjust.step.setup("cal_ACV_700V_300kHz_1pct")
cal.adjust.step.execute("cal_ACV_700V_300kHz_1pct")
--Use AC voltage setup
cal.adjust.step.setup("cal_ACV_700V_1kHz_fs")
cal.adjust.step.execute("cal_ACV_700V_1kHz_fs")
--Use AC current setup
cal.adjust.step.setup("cal_ACI_100uA_1kHz_tenth")
cal.adjust.step.execute("cal_ACI_100uA_1kHz_tenth")
--Use AC current setup
cal.adjust.step.setup("cal_ACI_100uA_1kHz_fs")
cal.adjust.step.execute("cal_ACI_100uA_1kHz_fs")
--Use AC current setup
cal.adjust.step.setup("cal_ACI_1mA_1kHz_tenth")
cal.adjust.step.execute("cal_ACI_1mA_1kHz_tenth")
--Use AC current setup
cal.adjust.step.setup("cal_ACI_1mA_1kHz_fs")
cal.adjust.step.execute("cal_ACI_1mA_1kHz_fs")
--Use AC current setup
cal.adjust.step.setup("cal_ACI_10mA_1kHz_tenth")
cal.adjust.step.execute("cal_ACI_10mA_1kHz_tenth")
--Use AC current setup
cal.adjust.step.setup("cal_ACI_10mA_10Hz_fs")
cal.adjust.step.execute("cal_ACI_10mA_10Hz_fs")
--Use AC current setup
cal.adjust.step.setup("cal_ACI_10mA_10kHz_fs")
cal.adjust.step.execute("cal_ACI_10mA_10kHz_fs")
--Use AC current setup
cal.adjust.step.setup("cal_ACI_10mA_1kHz_fs")
cal.adjust.step.execute("cal_ACI_10mA_1kHz_fs")
--Use AC current setup
cal.adjust.step.setup("cal_ACI_100mA_1kHz_tenth")
cal.adjust.step.execute("cal_ACI_100mA_1kHz_tenth")
--Use AC current setup
cal.adjust.step.setup("cal_ACI_100mA_1kHz_fs")
cal.adjust.step.execute("cal_ACI_100mA_1kHz_fs")
--Use AC current setup
cal.adjust.step.setup("cal_ACI_100mA_10Hz_fs")
cal.adjust.step.execute("cal_ACI_100mA_10Hz_fs")
--Use AC current setup
```

```
cal.adjust.step.setup("cal_ACI_200mA_1kHz_fs")
cal.adjust.step.execute("cal_ACI_200mA_1kHz_fs")
--Use AC current setup
cal.adjust.step.setup("cal_ACI_200mA_10kHz_fs")
cal.adjust.step.execute("cal_ACI_200mA_10kHz_fs")
--Use AC current setup
cal.adjust.step.setup("cal_ACI_1A_1kHz_tenth")
cal.adjust.step.execute("cal_ACI_1A_1kHz_tenth")
--Use AC current setup
cal.adjust.step.setup("cal_ACI_1A_10Hz_fs")
cal.adjust.step.execute("cal_ACI_1A_10Hz_fs")
--Use AC current setup
cal.adjust.step.setup("cal_ACI_1A_1kHz_fs")
cal.adjust.step.execute("cal_ACI_1A_1kHz_fs")
--Use AC current setup
cal.adjust.step.setup("cal_ACI_3A_1kHz_tenth")
cal.adjust.step.execute("cal_ACI_3A_1kHz_tenth")
--Use AC current setup
cal.adjust.step.setup("cal_ACI_3A_1kHz_fs")
cal.adjust.step.execute("cal_ACI_3A_1kHz_fs")
--Use AC current 10 A setup
cal.adjust.step.setup("cal_ACI_10A_400Hz_tenth")
cal.adjust.step.execute("cal_ACI_10A_400Hz_tenth")
--Use AC current 10 A setup
cal.adjust.step.setup("cal_ACI_10A_400Hz_fs")
cal.adjust.step.execute("cal_ACI_10A_400Hz_fs")
--Use AC current 10 A setup
cal.adjust.step.setup("cal_ACI_10A_5kHz_fs")
cal.adjust.step.execute("cal_ACI_10A_5kHz_fs")
--Use AC current 10 A setup
cal.adjust.step.setup("cal_ACI_10A_400Hz_2A")
cal.adjust.step.execute("cal_ACI_10A_400Hz_2A")
--Use AC current 10 A setup
cal.adjust.step.setup("cal_ACI_10A_10Hz_2A")
cal.adjust.step.execute("cal_ACI_10A_10Hz_2A")
--Use frequency setup
cal.adjust.step.setup("cal_FREQ_1kHz")
cal.adjust.step.execute("cal_FREQ_1kHz")
```

Enable temperature correction

After your adjustments are complete, turn on temperature correction. Run the following command to turn on temperature correction.

```
cal.adjust.step.setup("TC_EN")
cal.adjust.step.execute("TC_EN", 1)
```

Save calibration and set the adjustment dates

Use the following commands to save and lock calibration adjustments. These steps will take seconds to complete.

```
cal.save()
cal.lock()
```

NOTE

Calibration is temporary until you send the `cal.save()` command. Also, calibration data is not saved if calibration is locked, if invalid data exists.

This completes the remote calibration adjustment procedure.

Setting time, adjustment, and verification dates

The DMM6500 calibration adjustment date variable is set automatically to the present system time when the `cal.save()` command is executed. However, you can also use Test Script Processor (TSP®) commands to set the time, verification date, and adjustment date.

To set the DMM6500 time, adjust date, and verify date using TSP commands:

```
-- Unlock calibration (if not already unlocked).
cal.unlock("KI000CAL")
-- Set the time (year, month, date, hour, minutes, seconds).
localnode.settime(2018, 1, 9, 10, 4, 38)
-- Set the adjustment and verification dates.
cal.adjust.date = os.time({year = 2018, month = 1, day = 9})
cal.verify.date = os.time({year = 2018, month = 1, day = 9})
```

NOTE

The `cal.verify.date` command is used to record the date of the last verification that was done independently of DMM6500 adjustment. Typically, this date is set at the completion of a performance verification procedure.

NOTE

Calibration must be unlocked to change the adjustment and verification dates, but changing these dates does not require using the `cal.save()` command and does not affect the `cal.count` command.

Adjustment command timing and error checking

Before each adjustment step, the input of the DMM6500 must be connected to an appropriate reference signal, as documented in [Remote calibration adjustment procedures](#) (on page 3-6).

NOTE

You must make sure that the correct signal is connected and fully settled before sending the associated `cal.adjust` command. Failing to wait for a signal to settle completely may result in a poor-quality adjustment that could cause the DMM6500 to fail later performance verification.

Once the reference signal is stable, sending the calibration adjustment command initiates internal measurement operations in the DMM6500. These steps can take from a few seconds to 30 seconds to complete.

Another method of getting calibration status feedback is to use the TSP prompts mode of operation. This is especially useful when you are entering `cal.adjust` commands interactively from an ethernet Telnet session.

To enable prompts mode, send the `localnode.prompts = 1` command. This causes the DMM6500 to return a `TSP>` prompt to the computer screen when it has completed a step and is ready for the next command. Prompts mode also returns a `TSP?` prompt if an event message is available (for example, if an error occurs during an adjustment step). See [Handling events](#) (on page 3-39) for more information.

Although not prohibited, prompts mode is not recommended for automated test programs. If prompts mode is enabled in an automated test, the control program must be constructed to expect and read each prompt that is sent after each TSP command is processed (including queries). Distinguishing prompt messages from normal query responses will cause unnecessary complications to the control program and should be avoided.

Handling events

If an error occurs while performing a calibration adjustment step, the DMM6500 displays an error message on the front panel. Typically, errors occur during calibration adjustment only if something is wrong with the test setup or reference signal (for example, if the calibrator output is not enabled before sending a `cal.adjust` command). After correcting the cause, the `cal.adjust` command that generated an error can be sent again without having to restart the entire calibration adjustment sequence. An automated test program can check for errors using the `eventlog.next()` function. Refer to the *DMM6500 Reference Manual* for details on `eventlog` commands. The same text that is displayed after a `cal.adjust` error is returned in the `eventlog.next()` message.

TSP command reference

In this section:

[TSP commands..... 4-1](#)

TSP commands

The TSP commands available for the instrument are listed in alphabetic order.

Introduction

This section contains detailed information on the DMM6500 remote calibration commands.

cal.adjust.count

This attribute returns the number of times the instrument has been adjusted.

Type	TSP-Link accessible	Affected by	Where saved	Default value
Attribute (R)	Yes	Not applicable	Nonvolatile memory	Not applicable

Usage

```
adjustments = cal.adjust.count
```

<i>adjustments</i>	The number of adjustments
--------------------	---------------------------

Details

You can use this command if calibration is locked or unlocked.

The adjust count is read-only. The count is automatically incremented by one when the `cal.save()` command is sent with calibration unlocked.

Example

```
Count = cal.adjust.count
print(Count)
```

Assign the number of times the instrument has been adjusted to a user variable named `Count`.

Output the value. Example output:

```
3
```

This shows that the instrument has been adjusted 3 times.

Also see

[cal.adjust.date](#) (on page 4-2)

cal.adjust.date

This attribute contains the date when the instrument was last adjusted.

Type	TSP-Link accessible	Affected by	Where saved	Default value
Attribute (RW)	Yes	Not applicable	Nonvolatile memory	Not applicable

Usage

```
adjustDate = cal.adjust.date
cal.adjust.date = (os.time{year = year, month = month, day = day})
cal.adjust.date = (os.time({year = year, month = month, day = day, hour = hour, min
    = minute, sec = second}))
```

<i>adjustDate</i>	The date when the last adjustment occurred
<i>year</i>	Year; must be more than 1970
<i>month</i>	Month (1 to 12)
<i>day</i>	Day (1 to 31)
<i>hour</i>	Hour in 24-hour time format (0 to 23)
<i>minute</i>	Minute (0 to 59)
<i>second</i>	Second (0 to 59)

Details

The date and time is returned in the format:

MMM DD YYYY HH:MM:SS.NNN

Where:

- MMM DD YYYY is the month, date, and year
- HH:MM:SS.NNN is the hour, minute, second, and fractional second

You can read this command if calibration is locked or unlocked. To set the date and time, calibration must be unlocked.

Example

<pre>lastCal = cal.adjust.date print(lastCal)</pre>	<p>Assign the last adjustment date of the instrument to a user variable named <code>lastCal</code>.</p> <p>Output the value. Example output: Sep 23 2018 10:07:51.447</p>
---	---

Also see

[cal.adjust.count](#) (on page 4-1)

cal.adjust.step.setup()

This function sets up the specified adjustment step.

Type	TSP-Link accessible	Affected by	Where saved	Default value
Function	Yes			

Usage

```
cal.adjust.step.setup(stepname)
cal.adjust.step.setup(stepname, value)
```

<i>stepname</i>	The adjustment step to start
<i>value</i>	The value for this adjustment step. If using the default then value is optional

Details

This command generates an error if:

- Calibration is locked
- The step does not complete successfully
- The value that is passed is invalid for the step, out of range, or not needed

Also see

[cal.lock\(\)](#) (on page 4-5)
[cal.unlock\(\)](#) (on page 4-8)

cal.adjust.step.execute()

This function executes the specified adjustment step.

Type	TSP-Link accessible	Affected by	Where saved	Default value
Function	Yes			

Usage

```
cal.adjust.step.execute(stepname)
cal.adjust.step.execute(stepname, value)
```

<i>stepname</i>	The adjustment step to start
<i>value</i>	Value for this adjustment step. If using the default then value is optional

Details

This command generates an error if:

- Calibration is locked
- The step does not complete successfully
- The value that is passed is invalid for the step, out of range, or not needed

Also see

[cal.lock\(\)](#) (on page 4-5)
[cal.unlock\(\)](#) (on page 4-8)

cal.lock()

This function prevents access to instrument calibration.

Type	TSP-Link accessible	Affected by	Where saved	Default value
Function	Yes			

Usage

```
cal.lock()
```

Details

Calibration data is locked during normal operation. To perform calibration, you must unlock calibration.

This command does not save calibration data.

NOTE

Calibration data is lost if it is you do not save it before sending `cal.lock()`. Use `cal.save()` to save the data.

An error is generated if this command is issued when calibration is already locked.

Example

```
cal.unlock("KI000CAL")
-- Perform operations to generate the calibration data
cal.save()
cal.lock()
```

Unlock the calibration for the instrument using the default password.
Save the calibration data.
Lock the calibration data.

Also see

[cal.save\(\)](#) (on page 4-7)
[cal.unlock\(\)](#) (on page 4-8)

cal.password

This attribute sets the password that you send when you unlock calibration.

Type	TSP-Link accessible	Affected by	Where saved	Default value
Attribute (W)	Yes	Not applicable	Nonvolatile memory	KI000CAL

Usage

```
cal.password = "password"
```

<i>password</i>	A string that contains the password to unlock calibration; maximum of 10 characters
-----------------	---

Details

This command can only be sent when calibration is unlocked.

The password is not saved until calibration is saved with `cal.save()`.

NOTE

Be sure to record the password; there is no command to retrieve the password once it is set.

Example

```
cal.unlock("KI000CAL")
cal.password = "XYZCorp"
cal.lock()
cal.unlock("XYZCorp")
```

To change the default calibration password, unlock the calibration with the default password. Sets the password to `XYZCorp`. Lock calibration. Use the password `XYZCorp` for subsequent unlocks.

Also see

[cal.save\(\)](#) (on page 4-7)

[cal.unlock\(\)](#) (on page 4-8)

cal.save()

This function saves the calibration constants.

Type	TSP-Link accessible	Affected by	Where saved	Default value
Function	Yes			

Usage

```
cal.save()
```

Details

This command stores the internally calculated calibration constants that were derived during the comprehensive calibration procedure. It also sets the adjustment date and increments the adjustment count. Calibration constants are retained indefinitely once saved.

Calibration is temporary unless the changes are saved. Calibration data is not saved if:

- Calibration is locked.
- Invalid data exists (for example, if a calibration step failed or was aborted).

Example

```
cal.unlock("KI000CAL")
-- Perform operations to generate the calibration data
cal.save()
cal.lock()
```

Unlock the calibration for the instrument using the default password.
Save the calibration data.
Lock the calibration data.

Also see

[cal.adjust.count](#) (on page 4-1)
[cal.adjust.date](#) (on page 4-2)
[cal.lock\(\)](#) (on page 4-5)
[cal.unlock\(\)](#) (on page 4-8)

cal.unlock()

This attribute unlocks calibration operations.

Type	TSP-Link accessible	Affected by	Where saved	Default value
Function	No			

Usage

```
cal.unlock("password")
```

<i>password</i>	A string containing the password to unlock calibration
-----------------	--

Details

Calibration data is locked during normal operation. To perform calibration, you must unlock calibration.

The default password is `KI000CAL`. You can use `cal.password` to change the default.

An error is generated if this command is issued when calibration is already unlocked.

Example

```
cal.unlock("KI000CAL")
-- Perform operations to generate the calibration data
cal.save()
cal.lock()
```

Unlock the calibration for the instrument using the default password.
Save the calibration data.
Lock the calibration data.

Also see

[cal.lock\(\)](#) (on page 4-5)
[cal.password](#) (on page 4-6)

cal.verify.date

This attribute contains the date of the last calibration verification.

Type	TSP-Link accessible	Affected by	Where saved	Default value
Attribute (RW)	Yes	Not applicable	Nonvolatile memory	Not applicable

Usage

```
verifyDate = cal.verify.date
cal.verify.date = os.time({year = year, month = month, day = day})
cal.verify.date = os.time({year = year, month = month, day = day, hour = hour, min
    = minute, sec = second})
```

<i>verifyDate</i>	The date when the last verification occurred
<i>year</i>	Year; must be more than 1970
<i>month</i>	Month (1 to 12)
<i>day</i>	Day (1 to 31)
<i>hour</i>	Hour in 24-hour time format (0 to 23)
<i>minute</i>	Minute (0 to 59)
<i>second</i>	Second (0 to 59)

Details

The date and time is returned in the format:

MMM DD YYYY HH:MM:SS.NNN

Where:

- MMM DD YYYY is the month, date, and year
- HH:MM:SS.NNN is the hour, minute, second, and fractional second

You can read this command if calibration is locked or unlocked. To set the date and time, calibration must be unlocked.

When using the `os.time()` function, if no parameters are specified, the current date and time of the instrument is used.

The verification date is also available from the front panel:

1. Press the **MENU** key.
2. Select **Calibration**.
3. The verification date is displayed as the **Calibration Date**.

Example 1

```
cal.verify.date = os.time({year=2018, month=9, day=5})
print(cal.verify.date)
```

Set the verify calibration date to September 5, 2018.

Verify the date. Example output:

```
Sep 5 2014 12:00:00.000
```

Example 2

```
cal.verify.date = os.time()
```

Set the calibration verification to the present date of the instrument.

Also see

[cal.adjust.date](#) (on page 4-2)

Specifications are subject to change without notice.
All Keithley trademarks and trade names are the property of Keithley Instruments.
All other trademarks and trade names are the property of their respective companies.

Keithley Instruments
Corporate Headquarters • 28775 Aurora Road • Cleveland, Ohio 44139 • 440-248-0400 • Fax: 440-248-6168 • 1-800-935-5595 • www.tek.com/keithley

