

**KEITHLEY**

# DAC-02

User's Guide



A GREATER MEASURE OF CONFIDENCE

# WARRANTY

## Hardware

Keithley Instruments, Inc. warrants that, for a period of one (1) year from the date of shipment (3 years for Models 2000, 2001, 2002, 2010 and 2700), the Keithley Hardware product will be free from defects in materials or workmanship. This warranty will be honored provided the defect has not been caused by use of the Keithley Hardware not in accordance with the instructions for the product. This warranty shall be null and void upon: (1) any modification of Keithley Hardware that is made by other than Keithley and not approved in writing by Keithley or (2) operation of the Keithley Hardware outside of the environmental specifications therefore.

Upon receiving notification of a defect in the Keithley Hardware during the warranty period, Keithley will, at its option, either repair or replace such Keithley Hardware. During the first ninety days of the warranty period, Keithley will, at its option, supply the necessary on site labor to return the product to the condition prior to the notification of a defect. Failure to notify Keithley of a defect during the warranty shall relieve Keithley of its obligations and liabilities under this warranty.

## Other Hardware

The portion of the product that is not manufactured by Keithley (Other Hardware) shall not be covered by this warranty, and Keithley shall have no duty of obligation to enforce any manufacturers' warranties on behalf of the customer. On those other manufacturers' products that Keithley purchases for resale, Keithley shall have no duty of obligation to enforce any manufacturers' warranties on behalf of the customer.

## Software

Keithley warrants that for a period of one (1) year from date of shipment, the Keithley produced portion of the software or firmware (Keithley Software) will conform in all material respects with the published specifications provided such Keithley Software is used on the product for which it is intended and otherwise in accordance with the instructions therefore. Keithley does not warrant that operation of the Keithley Software will be uninterrupted or error-free and/or that the Keithley Software will be adequate for the customer's intended application and/or use. This warranty shall be null and void upon any modification of the Keithley Software that is made by other than Keithley and not approved in writing by Keithley.

If Keithley receives notification of a Keithley Software nonconformity that is covered by this warranty during the warranty period, Keithley will review the conditions described in such notice. Such notice must state the published specification(s) to which the Keithley Software fails to conform and the manner in which the Keithley Software fails to conform to such published specification(s) with sufficient specificity to permit Keithley to correct such nonconformity. If Keithley determines that the Keithley Software does not conform with the published specifications, Keithley will, at its option, provide either the programming services necessary to correct such nonconformity or develop a program change to bypass such nonconformity in the Keithley Software. Failure to notify Keithley of a nonconformity during the warranty shall relieve Keithley of its obligations and liabilities under this warranty.

## Other Software

OEM software that is not produced by Keithley (Other Software) shall not be covered by this warranty, and Keithley shall have no duty or obligation to enforce any OEM's warranties on behalf of the customer.

## Other Items

Keithley warrants the following items for 90 days from the date of shipment: probes, cables, rechargeable batteries, diskettes, and documentation.

## Items not Covered under Warranty

This warranty does not apply to fuses, non-rechargeable batteries, damage from battery leakage, or problems arising from normal wear or failure to follow instructions.

## Limitation of Warranty

This warranty does not apply to defects resulting from product modification made by Purchaser without Keithley's express written consent, or by misuse of any product or part.

## Disclaimer of Warranties

EXCEPT FOR THE EXPRESS WARRANTIES ABOVE KEITHLEY DISCLAIMS ALL OTHER WARRANTIES, EXPRESS OR IMPLIED, INCLUDING WITHOUT LIMITATION, ALL IMPLIED WARRANTIES OF MERCHANTABILITY AND FITNESS FOR A PARTICULAR PURPOSE. KEITHLEY DISCLAIMS ALL WARRANTIES WITH RESPECT TO THE OTHER HARDWARE AND OTHER SOFTWARE.

## Limitation of Liability

KEITHLEY INSTRUMENTS SHALL IN NO EVENT, REGARDLESS OF CAUSE, ASSUME RESPONSIBILITY FOR OR BE LIABLE FOR: (1) ECONOMICAL, INCIDENTAL, CONSEQUENTIAL, INDIRECT, SPECIAL, PUNITIVE OR EXEMPLARY DAMAGES, WHETHER CLAIMED UNDER CONTRACT, TORT OR ANY OTHER LEGAL THEORY, (2) LOSS OF OR DAMAGE TO THE CUSTOMER'S DATA OR PROGRAMMING, OR (3) PENALTIES OR PENALTY CLAUSES OF ANY DESCRIPTION OR INDEMNIFICATION OF THE CUSTOMER OR OTHERS FOR COSTS, DAMAGES, OR EXPENSES RELATED TO THE GOODS OR SERVICES PROVIDED UNDER THIS WARRANTY.



Keithley Instruments, Inc.

28775 Aurora Road • Cleveland, Ohio 44139 • 440-248-0400 • Fax: 440-248-6168  
1-888-KEITHLEY (534-8453) • [www.keithley.com](http://www.keithley.com)

Sales Offices:	BELGIUM:	Bergensesteenweg 709 • B-1600 Sint-Pieters-Leeuw • 02-363 00 40 • Fax: 02/363 00 64
	CHINA:	Yuan Chen Xin Building, Room 705 • 12 Yumin Road, Dewai, Madian • Beijing 100029 • 8610-6202-2886 • Fax: 8610-6202-2892
	FINLAND:	Tietäjäntie 2 • 02130 Espoo • Phone: 09-54 75 08 10 • Fax: 09-25 10 51 00
	FRANCE:	3, allée des Garays • 91127 Palaiseau Cédex • 01-64 53 20 20 • Fax: 01-60 11 77 26
	GERMANY:	Landsberger Strasse 65 • 82110 Germering • 089/84 93 07-40 • Fax: 089/84 93 07-34
	GREAT BRITAIN:	Unit 2 Commerce Park, Brunel Road • Theale • Berkshire RG7 4AB • 0118 929 7500 • Fax: 0118 929 7519
	INDIA:	Flat 2B, Willocrissa • 14, Rest House Crescent • Bangalore 560 001 • 91-80-509-1320/21 • Fax: 91-80-509-1322
	ITALY:	Viale San Gimignano, 38 • 20146 Milano • 02-48 39 16 01 • Fax: 02-48 30 22 74
	JAPAN:	New Pier Takeshiba North Tower 13F • 11-1, Kaigan 1-chome • Minato-ku, Tokyo 105-0022 • 81-3-5733-7555 • Fax: 81-3-5733-7556
	KOREA:	2FL., URI Building • 2-14 Yangjae-Dong • Seocho-Gu, Seoul 137-888 • 82-2-574-7778 • Fax: 82-2-574-7838
	NETHERLANDS:	Postbus 559 • 4200 AN Gorinchem • 0183-635333 • Fax: 0183-630821
	SWEDEN:	c/o Regus Business Centre • Frosundaviks Allé 15, 4tr • 169 70 Solna • 08-509 04 679 • Fax: 08-655 26 10
	SWITZERLAND:	Kriesbachstrasse 4 • 8600 Dübendorf • 01-821 94 44 • Fax: 01-820 30 81
	TAIWAN:	1FL., 85 Po Ai Street • Hsinchu, Taiwan, R.O.C. • 886-3-572-9077 • Fax: 886-3-572-9031

# **DAC-02 User's Guide**

Revision B - July 1994  
Part Number: 61740

## **New Contact Information**

Keithley Instruments, Inc.  
28775 Aurora Road  
Cleveland, OH 44139

Technical Support: 1-888-KEITHLEY  
Monday – Friday 8:00 a.m. to 5:00 p.m (EST)  
Fax: (440) 248-6168

Visit our website at <http://www.keithley.com>

The following safety precautions should be observed before using this product and any associated instrumentation. Although some instruments and accessories would normally be used with non-hazardous voltages, there are situations where hazardous conditions may be present.

This product is intended for use by qualified personnel who recognize shock hazards and are familiar with the safety precautions required to avoid possible injury. Read and follow all installation, operation, and maintenance information carefully before using the product. Refer to the manual for complete product specifications.

If the product is used in a manner not specified, the protection provided by the product may be impaired.

The types of product users are:

**Responsible body** is the individual or group responsible for the use and maintenance of equipment, for ensuring that the equipment is operated within its specifications and operating limits, and for ensuring that operators are adequately trained.

**Operators** use the product for its intended function. They must be trained in electrical safety procedures and proper use of the instrument. They must be protected from electric shock and contact with hazardous live circuits.

**Maintenance personnel** perform routine procedures on the product to keep it operating properly, for example, setting the line voltage or replacing consumable materials. Maintenance procedures are described in the manual. The procedures explicitly state if the operator may perform them. Otherwise, they should be performed only by service personnel.

**Service personnel** are trained to work on live circuits, and perform safe installations and repairs of products. Only properly trained service personnel may perform installation and service procedures.

Keithley products are designed for use with electrical signals that are rated Installation Category I and Installation Category II, as described in the International Electrotechnical Commission (IEC) Standard IEC 60664. Most measurement, control, and data I/O signals are Installation Category I and must not be directly connected to mains voltage or to voltage sources with high transient over-voltages. Installation Category II connections require protection for high transient over-voltages often associated with local AC mains connections. Assume all measurement, control, and data I/O connections are for connection to Category I sources unless otherwise marked or described in the Manual.

Exercise extreme caution when a shock hazard is present. Lethal voltage may be present on cable connector jacks or test fixtures. The American National Standards Institute (ANSI) states that a shock hazard exists when voltage levels greater than 30V RMS, 42.4V peak, or 60VDC are present. **A good safety practice is to expect that hazardous voltage is present in any unknown circuit before measuring.**

Operators of this product must be protected from electric shock at all times. The responsible body must ensure that operators are prevented access and/or insulated from every connection point. In some cases, connections must be exposed to potential human contact. Product operators in these circumstances must be trained to protect themselves from the risk of electric shock. If the circuit is capable of operating at or above 1000 volts, **no conductive part of the circuit may be exposed.**

Do not connect switching cards directly to unlimited power circuits. They are intended to be used with impedance limited sources. NEVER connect switching cards directly to AC mains. When connecting sources to switching cards, install protective devices to limit fault current and voltage to the card.

Before operating an instrument, make sure the line cord is connected to a properly grounded power receptacle. Inspect the connecting cables, test leads, and jumpers for possible wear, cracks, or breaks before each use.

When installing equipment where access to the main power cord is restricted, such as rack mounting, a separate main input power disconnect device must be provided, in close proximity to the equipment and within easy reach of the operator.

For maximum safety, do not touch the product, test cables, or any other instruments while power is applied to the circuit under test. ALWAYS remove power from the entire test system and discharge any capacitors before: connecting or disconnecting cables or jumpers, installing or removing switching cards, or making internal changes, such as installing or removing jumpers.

Do not touch any object that could provide a current path to the common side of the circuit under test or power line (earth) ground. Always make measurements with dry hands while standing on a dry, insulated surface capable of withstanding the voltage being measured.



The instrument and accessories must be used in accordance with its specifications and operating instructions or the safety of the equipment may be impaired.

Do not exceed the maximum signal levels of the instruments and accessories, as defined in the specifications and operating information, and as shown on the instrument or test fixture panels, or switching card.

When fuses are used in a product, replace with same type and rating for continued protection against fire hazard.

Chassis connections must only be used as shield connections for measuring circuits, NOT as safety earth ground connections.

If you are using a test fixture, keep the lid closed while power is applied to the device under test. Safe operation requires the use of a lid interlock.

If  or  is present, connect it to safety earth ground using the wire recommended in the user documentation.

The  symbol on an instrument indicates that the user should refer to the operating instructions located in the manual.

The  symbol on an instrument shows that it can source or measure 1000 volts or more, including the combined effect of normal and common mode voltages. Use standard safety precautions to avoid personal contact with these voltages.

The **WARNING** heading in a manual explains dangers that might result in personal injury or death. Always read the associated information very carefully before performing the indicated procedure.

The **CAUTION** heading in a manual explains hazards that could damage the instrument. Such damage may invalidate the warranty.

Instrumentation and accessories shall not be connected to humans.

Before performing any maintenance, disconnect the line cord and all test cables.

To maintain protection from electric shock and fire, replacement components in mains circuits, including the power transformer, test leads, and input jacks, must be purchased from Keithley Instruments. Standard fuses, with applicable national safety approvals, may be used if the rating and type are the same. Other components that are not safety related may be purchased from other suppliers as long as they are equivalent to the original component. (Note that selected parts should be purchased only through Keithley Instruments to maintain accuracy and functionality of the product.) If you are unsure about the applicability of a replacement component, call a Keithley Instruments office for information.

To clean an instrument, use a damp cloth or mild, water based cleaner. Clean the exterior of the instrument only. Do not apply cleaner directly to the instrument or allow liquids to enter or spill on the instrument. Products that consist of a circuit board with no case or chassis (e.g., data acquisition board for installation into a computer) should never require cleaning if handled according to instructions. If the board becomes contaminated and operation is affected, the board should be returned to the factory for proper cleaning/servicing.

The information contained in this manual is believed to be accurate and reliable. However, Keithley Instruments, Inc., assumes no responsibility for its use or for any infringements of patents or other rights of third parties that may result from its use. No license is granted by implication or otherwise under any patent rights of Keithley Instruments, Inc.

KEITHLEY INSTRUMENTS, INC., SHALL NOT BE LIABLE FOR ANY SPECIAL, INCIDENTAL, OR CONSEQUENTIAL DAMAGES RELATED TO THE USE OF THIS PRODUCT. THIS PRODUCT IS NOT DESIGNED WITH COMPONENTS OF A LEVEL OF RELIABILITY SUITABLE FOR USE IN LIFE SUPPORT OR CRITICAL APPLICATIONS.

Refer to your Keithley Instruments license agreement and Conditions of Sale document for specific warranty and liability information.

MetraByte is a trademark of Keithley Instruments, Inc. All other brand and product names are trademarks or registered trademarks of their respective companies.

© Copyright Keithley Instruments, Inc., 1984, 1994.

All rights reserved. Reproduction or adaptation of any part of this documentation beyond that permitted by Section 117 of the 1976 United States Copyright Act without permission of the Copyright owner is unlawful.

**Ke**

Tel





# Table of Contents

	<b>Preface</b>	
<b>1</b>	<b>Overview</b>	
	Features and Applications . . . . .	1-1
	Supporting Software . . . . .	1-2
	Accessories . . . . .	1-2
<b>2</b>	<b>Functional Description</b>	
<b>3</b>	<b>Setup and Installation</b>	
	Unpacking and Inspecting . . . . .	3-1
	Installing the Software Package . . . . .	3-2
	Configuring the Board . . . . .	3-2
	Installing the Board . . . . .	3-5
<b>4</b>	<b>Cabling and Wiring</b>	
	Attaching an STA-U . . . . .	4-2
	Selecting Output Ranges . . . . .	4-2
	Using the 4 to 20 mA Current Loop Output . . . . .	4-3
	Using an AC Reference (Digital Attenuator) . . . . .	4-5
<b>5</b>	<b>The Control Panel</b>	
<b>6</b>	<b>Programming</b>	
	I/O Address Map . . . . .	6-1
	Data Format . . . . .	6-2
	Programming Examples . . . . .	6-3
<b>7</b>	<b>Calibration</b>	
	Equipment Requirements . . . . .	7-1
	Calibration Program . . . . .	7-1

<b>8</b>	<b>Troubleshooting</b>	
	Problem Isolation . . . . .	8-1
	Identifying Symptoms and Possible Causes . . . . .	8-1
	Testing the Board and Host Computer . . . . .	8-4
	Testing the Accessory Slot and I/O Connections . . . . .	8-4
	Technical Support . . . . .	8-5
<b>A</b>	<b>Specifications</b>	
<b>B</b>	<b>Connector Pin Assignments</b>	

**Index**

**List of Figures**

Figure 2-1.	Block Diagram of DAC-02 . . . . .	2-1
Figure 3-1.	Base Address Switch Location . . . . .	3-3
Figure 4-1.	Pin Assignments for the Main I/O Connector . . . . .	4-1
Figure 4-2.	Attaching an STA-U . . . . .	4-2
Figure 4-3.	4 to 20 mA Current Loop Output Configuration . . . . .	4-4
Figure 4-4.	4 to 20 mA Current Output (Floating Load) . . . . .	4-4
Figure 4-5.	4 to 20 mA Current Output (Grounded Load) . . . . .	4-5
Figure 4-6.	DAC-02 Equivalent Circuit when Using an AC Reference . . . . .	4-5
Figure B-1.	Main I/O Connector Pin Assignments . . . . .	B-1

**List of Tables**

Table 3-1.	Values of Base Address Switch Positions . . . . .	3-3
Table 3-2.	Standard Address Assignments . . . . .	3-4
Table 4-1.	Pin Wiring for Output Ranges . . . . .	4-2
Table 6-1.	DAC-02 Register I/O Address Map . . . . .	6-1
Table 6-2.	DAC Data Format . . . . .	6-2
Table 8-1.	Troubleshooting Information . . . . .	8-2
Table A-1.	DAC-02 Specifications . . . . .	A-1
Table A-2.	Environmental Specifications . . . . .	A-2
Table A-3.	Power Specifications . . . . .	A-2

# Preface

The *DAC-02 User's Guide* is intended to help you understand the installation, interface requirements, functions, and operation of the DAC-02 board. This guide focuses primarily on describing the board and its capabilities, setting up the board and its associated software, making typical hookups, and operating the Control Panel software. There are also chapters on calibration and troubleshooting. To follow the information and instructions contained in this manual, you must be familiar with the operation of an IBM<sup>®</sup> PC/XT<sup>™</sup>, PC AT<sup>®</sup>, or compatible computer in the MS-DOS<sup>®</sup> or Windows<sup>™</sup> environments. You must also be familiar with data acquisition principles and applications.

The *DAC-02 User's Guide* is organized as follows:

- Chapter 1 describes features, accessories, and software options of the board.
- Chapter 2 summarizes operating features of the board. This chapter contains a block diagram and brief descriptions of the features as they relate to your options for setting up and using the boards.
- Chapter 3 contains instructions for inspection, software installation, configuration, and board installation.
- Chapter 4 shows the preferred methods for making I/O (input/output) connections, using the available accessories and cables.
- Chapter 5 provides starting instructions and a brief description of the Control Panel program.
- Chapter 6 provides an I/O address map, programming information, and programming examples.

- Chapter 7 discusses calibration requirements and the calibration program.
- Chapter 8 contains information on isolating and determining the source of operating problems. This chapter also contains instructions for obtaining technical support.
- Appendix A contains specifications for the DAC-02 board.
- Appendix B contains pin assignments for the main I/O connector of the DAC-02 board.
- An index completes the manual.

# Overview

The DAC-02 is a 2-channel, 12-bit analog output board packaged in a 5-inch, half-slot length suitable for an accessory slot of an IBM PC/XT, PC AT, or compatible computer. This chapter lists features and applications of the board and describes supporting software and accessories.

## Features and Applications

---

Features of the DAC-02 are as follows:

- Two analog output channels
- 12-bit resolution
- 0 to 5, 0 to 10,  $\pm 5$ , and  $\pm 10$  V output ranges
- 4 to 20 mA current-loop (sink) capability
- Software for configuration, calibration, test, and operation

Typical applications for the DAC-02 are as follows:

- Servo control
- Programmable amplifier
- 12-bit resolution voltage source
- Function generator

# Supporting Software

---

The software package for the DAC-02 is provided on 3.5-inch or 5.25-inch diskettes. This package includes example programs in Microsoft® QuickBasic™ 4.5, Microsoft Professional BASIC, C, Pascal, and Microsoft Visual Basic™ for Windows™. The package also includes support files and the following utility programs:

- **Configuration Utility** - This utility (CFG02.EXE) is a configuration program for setting the base address of the DAC-02.
- **Calibration Utility** - This utility (CAL02.EXE) is a program for calibrating and testing the DAC-02.
- **Control Panel** - The Control Panel is a stand-alone program (CTL02W.EXE) supplied for Windows. This program provides access to all DAC-02 board operations without programming. The Control Panel is a means of testing the board and your application; it is also a means of performing simple applications. Refer to Chapter 5 for more information about the Control Panel.
- **PORTIO.DLL** - A DLL (Dynamic Link Library) providing I/O functions to users of Visual Basic for Windows and any other languages that can access a DLL. PORTIO.DLL is an aid for writing Windows-based application programs. The full purpose and use of PORTIO.DLL are discussed in the accompanying file, PORTIO.TXT.

# Accessories

---

The following accessories are available for use with the DAC-02:

- **STA-U** - Screw terminal accessory that enables all signals of the DAC-02 to be accessible through screw-terminal connections. Use a K-1800 cable to connect this accessory to the DAC-02.
- **K-1800** - An 18-inch ribbon cable terminated at each end with a 25-pin, female, type D connector.

# 2

## Functional Description

This chapter describes the features of the DAC-02 board to familiarize you with the operating options and to enable you to make the best use of your board. Figure 2-1 shows a block diagram of the DAC-02 board.

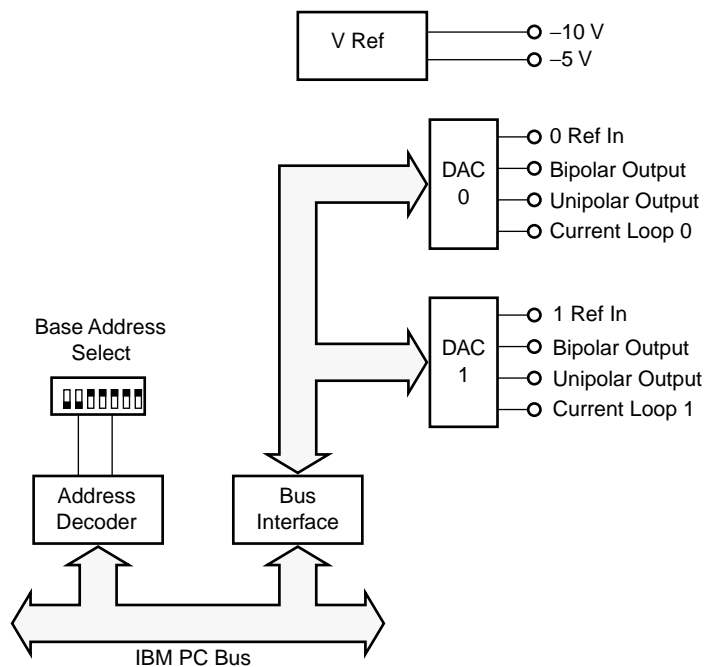

**Figure 2-1. Block Diagram of DAC-02**

The DAC-02 board consists of two separate, double-buffered, 12-bit, multiplying DACs (digital-to-analog converters) and interface circuitry.

The DACs can operate as conventional D/A (digital-to-analog) converters if they are used with a fixed DC reference. Using the DACs with the onboard fixed DC references of  $-5\text{ V}$  and  $-10\text{ V}$  provides output ranges as follows:

- 0 to 10 V
- 0 to 5 V
- $\pm 5\text{ V}$
- $\pm 10\text{ V}$
- 4 to 20 mA current loop (sink)

Alternatively, the DACs can operate as multiplying D/A converters if they are used with a variable or AC reference. As multiplying D/A converters, the DAC outputs are the product of reference and digital inputs. With an AC reference, the unipolar outputs provide 2-quadrant multiplication, or the bipolar outputs provide 4-quadrant operation. With an AC reference, the DACs also maintain 12-bit accuracy up to 1 kHz.



# Setup and Installation

This chapter contains instructions for installing the DAC-02 board. The installation task includes three basic steps: unpacking and inspecting the board, setting the configuration switches and jumpers, and installing the board in the computer. These steps are described in the sections that follow.

## Unpacking and Inspecting

---

---

**Caution:** A discharge of static electricity from your hands can seriously damage certain electrical components on any circuit board. Before handling any board, discharge static electricity from yourself by touching a grounded conductor such as your computer chassis (your computer must be turned off) or by wearing an anti-static strap. Whenever you handle a board, hold it by the edges and avoid touching any board components.

---

Use the following procedure to unwrap and inspect a DAC-02 board.

1. Factory packaging of the DAC-02 board includes a final wrap of protective, anti-static material. Remove the board from its anti-static wrapping material. You may wish to store the wrapping material for possible future use.
2. Inspect the board for signs of damage. If damage is apparent, arrange to return the board to the factory (see “Technical Support” on page 8-5).

3. Check the remaining contents of your package against the packing list to be sure your order is complete. Report any missing items, immediately.
4. When you are satisfied with the inspection, proceed with the software and hardware setup instructions.

## Installing the Software Package

---

Before you work with the DAC-02 software, copy the software package diskette either to your computer hard drive or to another diskette. If you copy the software to your computer hard drive, make a new directory to contain the software, such as *DAC02*. Store the original diskette as a backup.

After you copy the software package, read the text file *FILES.TXT* to familiarize yourself with the contents of the package. Note that the Windows program CTL02W.EXE, the *Control Panel*, is available for the operation of your DAC-02. If you plan to use the Control Panel, read the text file *README.TXT* for installation instructions. If you plan to use the PORTIO.DLL to write applications in Visual Basic for Windows for operation of your DAC-02, read the text file *PORTIO.TXT* for information and for prototypes of I/O functions.

## Configuring the Board

---

The base address is specified through a switch setting. This switch is located as shown in Figure 3-1.

---

**Note:** When a position of the base address switch is set in the ON direction, it has zero value. For example, Figure 3-1 shows the switch positions set for a value of 300h or 768 decimal.

---

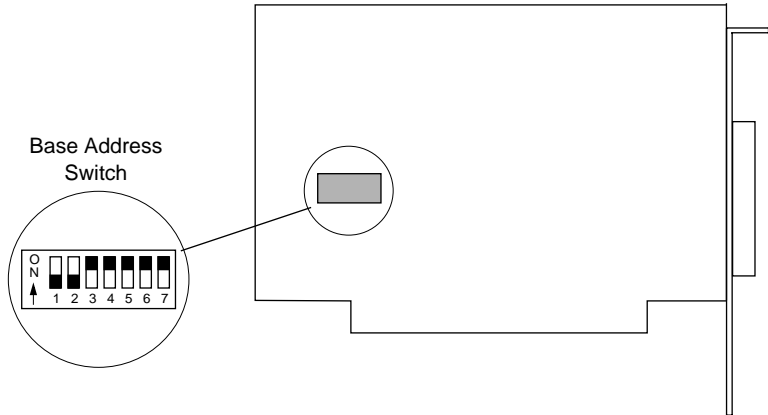

**Figure 3-1. Base Address Switch Location**

The base address switch is preset at the factory for 300h (see Figure 3-1). Check this setting against the needs of your application to be sure you have no conflicts. If the factory-set base address conflicts with the address of another device in your system, use the program CFG02.EXE to determine the settings for a new address. Table 3-1 lists the values for each position of the base address switch.

**Table 3-1. Values of Base Address Switch Positions**

Switch Position	Address Line	Value When Switch Is Off	
		Decimal	Hexadecimal
1	A9	512	200
2	A8	256	100
3	A7	128	80
4	A6	64	40
5	A5	32	20
6	A4	16	10
7	A3	8	8

The address you specify must be within the range of 200 to 3F8h (512 to 1008 decimal) and on a 8-byte boundary. When selecting a base address, do not select an address that conflicts with those already in use. Table 3-2 lists standard address assignments and their corresponding devices.

**Table 3-2. Standard Address Assignments**

<b>Address (Hexadecimal)</b>	<b>Device</b>	<b>Address (Hexadecimal)</b>	<b>Device</b>
000 - 0FF	Internal I/O	378 - 37F	Printer
100 - 1FF	Undecoded	380 - 389	Binary comm. 2
200 - 20F	Joy stick Port	380 - 38C	SDLC comm.
210 - 217	Expansion unit	390 - 39F	Available
218 - 21F	Available	3A0 - 3A9	Binary comm.
220 - 24F	Reserved	3AA - 3AF	Available
250 - 277	Available	3B0 - 3BF	Mono disp./printer
278 - 27F	Reserved	3C0 - 3CF	Reserved
280 - 2EF	Available	3D0 - 3DF	Color/graphics
2F0 - 2F7	Reserved	3E0 - 3E7	Reserved
2F8 - 2FF	Com2:	3E8 - 3EF	Available
300 - 31F	Available	3F0 - 3F7	Floppy disk
320 - 32F	Fixed disk	3F8 - 3FF	Com1:
330 - 377	Available	—	—

# Installing the Board

---

---

**Caution:** Installing or removing a board while power is on can damage your computer.

---

Use the following steps to install a DAC-02 board in an accessory slot of your computer:

1. Turn off power to the computer and all attached equipment.
2. Remove the computer chassis cover.
3. Select an unoccupied accessory slot, and remove the corresponding blank plate from the I/O connector panel.
4. Insert and secure the board in the selected slot.
5. Replace the computer cover.

You are now ready to attach accessories or other external connections to the board, as described in Chapter 4.

# 4

## Cabling and Wiring

This chapter shows the attachments you can add to the main I/O connector of your DAC-02 board. The main I/O connector of the DAC-02 is a 25-pin, D-type. Pin assignments for this connector are shown in Figure 4-1.

---

**Caution:** To avoid electrical damage, turn off power to the computer and any attached accessories before making connections to a DAC-02 board.

---

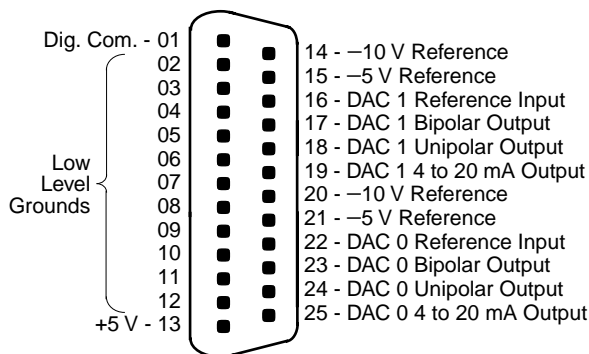

**Figure 4-1. Pin Assignments for the Main I/O Connector**

---

**Note:** The +5 V power from the computer is supplied on pin 13. If you use this power, avoid shorting or overloading the computer power supply.

---

## Attaching an STA-U

---

To attach an STA-U accessory to the DAC-02, use a K-1800 cable, as shown in Figure 4-2.

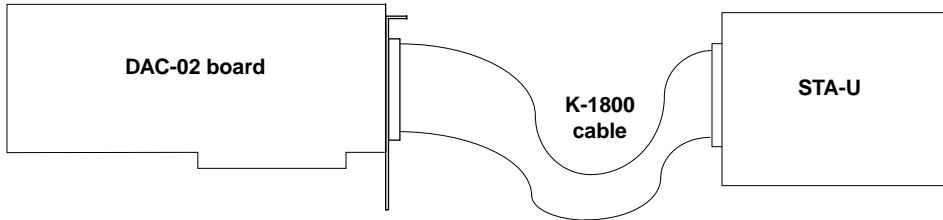

Figure 4-2. Attaching an STA-U

## Selecting Output Ranges

---

You select the output range of each DAC by jumpering pins on the mating connector for the main I/O connector or on the STA-U. The mating connector is a male DB25P solder-cup type (Keithley MetraByte part number SMC-25). Select the ranges according to the pin wiring in Table 4-1.

Table 4-1. Pin Wiring for Output Ranges

Range	DAC #	Jumper Pins	Output
0 to 5 V	0	21 to 22	Pin 24
	1	15 to 16	Pin 18
0 to 10 V	0	20 to 22	Pin 24
	1	14 to 16	Pin 18
$\pm 5$ V	0	21 to 22	Pin 23
	1	15 to 16	Pin 17

**Table 4-1. Pin Wiring for Output Ranges (cont.)**

Range	DAC #	Jumper Pins	Output
$\pm 10$ V	0	20 to 22	Pin 23
	1	14 to 16	Pin 17
4 to 20 mA	0	21 to 22	Pin 25
	1	15 to 16	Pin 19
AC Reference	0	In on pin 22 In on pin 22	Pin 24 (2-quadrant) Pin 23 (4-quadrant)
	1	In on pin 16 In on pin 16	Pin 18 (2-quadrant) Pin 17 (4-quadrant)

Low-level ground connections can be made to any of pins 2 to 12.

Data coding for unipolar outputs 0 to 5 V, 0 to 10 V, and 4 to 20 mA is true binary. Because of the analog inversion in bipolar outputs  $\pm 5$  V and  $\pm 10$  V, data coding is complementary offset binary (that is, zero corresponds to +full-scale analog, and 4095 corresponds to -full-scale analog).

## Using the 4 to 20 mA Current Loop Output

---

The 4 to 20 mA current loop output consists of a precision current sink, formed by a VMOS power FET, and a reverse-protection diode, as shown in Figure 4-3.



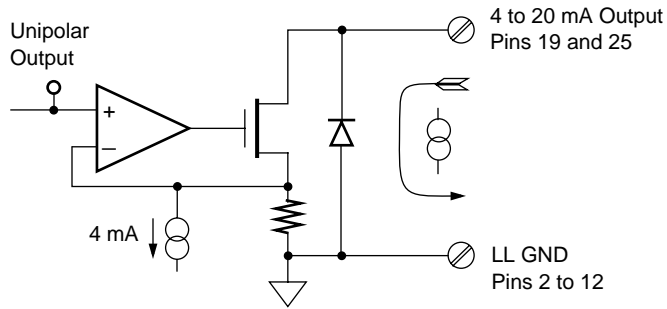

**Figure 4-3. 4 to 20 mA Current Loop Output Configuration**

You must maintain a minimum of 8 V across this output circuit to ensure correct operation. The maximum voltage should not exceed 36 V to stay within power-dissipation capabilities. A 24 or 36 V supply is ideal. Figures 4-4 and 4-5 shows two ways of connecting the process loop. The floating-load way allows additional loops to be powered by the same supply but constrains the load to 2-wire floating.

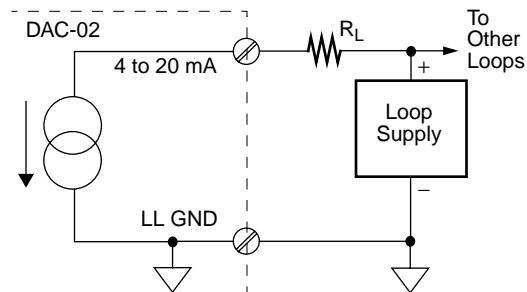

**Figure 4-4. 4 to 20 mA Current Output (Floating Load)**

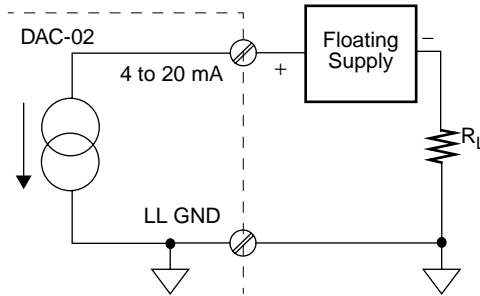

Figure 4-5. 4 to 20 mA Current Output (Grounded Load)

## Using an AC Reference (Digital Attenuator)

In addition to its uses as a standard DC output DAC, the DAC-02 can be used with a bipolar or AC reference signal. Figure 4-6 shows the equivalent circuit for the board when used in this mode.

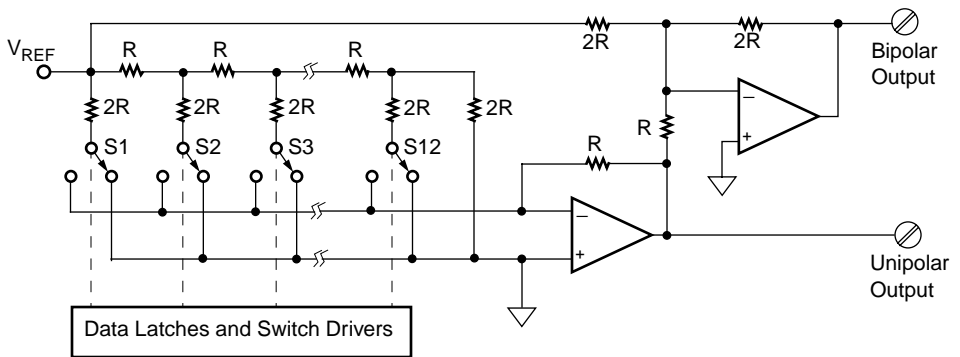

Figure 4-6. DAC-02 Equivalent Circuit when Using an AC Reference

The customary terminology for operation of a DAC-02 differs when you use an AC reference. If you take the output from the unipolar terminals, you get 2-quadrant operation because the reference, which may be positive or negative, is multiplied with a signal that is positive only. If you take the output from the bipolar terminals, the offset digital input can effectively be positive or negative, which together with the positive and negative states of the reference results in 4-quadrant operation.

Two other parameters are of interest in AC operation. The first parameter is feedthrough, the amount of residual signal at digital zero. Feedthrough, which is mainly a function of stray capacitance, rises with frequency. At 10 kHz, feedthrough is typically 5 mV peak-to-peak with a  $\pm 5$  V reference.

The second parameter, which is a limit at a lower frequency, is the accuracy/frequency characteristic. Because of distributed capacitance in the R-2R ladder network, the full 12-bit performance of the DAC falls off as the frequency rises. Above about 1 kHz, the dynamic performance of the DAC is less than 12 bits of accuracy.

The DAC-02 performs well in synchro-digital and resolver applications for sine/cosine generation with a 400 Hz reference.

# 5

## The Control Panel

The Control Panel is a utility program (CTL02W.EXE) for testing the functions of your DAC-02 boards in the Windows environment. This program is a part of the DAC-02 software package.

To use the Control Panel, perform the following steps:

1. Start the Control Panel from the Windows environment by clicking on Run in the File menu of the Program Manager and making the following entry in the Command Line dialogue box:

*path*\CTL02W

Use the Browse option to determine the path.

2. To configure the base address and DAC output ranges, select Config from the Control Panel menu.
3. To set up and perform an analog output operation, select Output from the Control Panel menu. When the Control Panel displays the Output menu, select Single to display the Single Point Output or Multiple to display Multiple Point Output setup panel for your entries.
4. To obtain information on the setup and performance of an operation, use the Help option in the Control Panel menu. To obtain information on DAC-02 board functions and parameters, refer to Chapter 2.
5. When you finish using the Control Panel, select Close to terminate the program.

# 6

## Programming

You can operate the DAC-02 by writing I/O commands in programming languages such as BASIC, QuickBasic, C, and Pascal. This chapter provides the register-level programming information you need for writing these I/O commands.

### I/O Address Map

---

The DAC-02 uses eight consecutive addresses in the I/O address space of the computer. The board's base address (Base Address +0h) determines where the registers of the board are located in the I/O space. Table 6-1 is a map of the DAC-02 register I/O addresses.

**Table 6-1. DAC-02 Register I/O Address Map**

I/O Address	Function		I/O Address	Function
Base Address +0h	DAC 0 low byte		Base Address +4h	DAC 0 low byte
Base Address +1h	DAC 0 high byte		Base Address +5h	DAC 0 high byte
Base Address +2h	DAC 1 low byte		Base Address +6h	DAC 1 low byte
Base Address +3h	DAC 1 high byte		Base Address +7h	DAC 1 high byte

Base addresses +4h to +7h are redundant; they repeat the pattern of the first four addresses and can be ignored during programming.

## Data Format

---

The 12-bit data is written to each DAC in two consecutive bytes. The first byte contains the four LSBs (least significant bits) of data. The second byte contains the eight MSBs (most significant bits) of data. The format of this data is shown in Table 6-2.

**Table 6-2. DAC Data Format**

Address	D7	D6	D5	D4	D3	D2	D1	D0
Low byte (Base Address +Even)	B9 (LSB)	B10 (LSB)	B11 (LSB)	B12 (LSB)	x <sup>1</sup>	x	x	x
High byte (Base Address +Odd)	B1 (MSB)	B2 (MSB)	B3 (MSB)	B4 (MSB)	B5 (MSB)	B6 (MSB)	B7 (MSB)	B8 (MSB)

**Notes**

<sup>1</sup> x = value irrelevant

The least significant byte is usually written first and is stored in an intermediate DAC register, having no effect on the output. When the most significant byte is written, its data is added to the stored data from the least significant byte and presented *broadside* to the DAC, thus assuring a single-step update. This process is known as double-buffering.

For 8-bit operation, first write zero to the low byte, then perform all further operations with the high byte only.

Assembly language programmers should note that if data is left-justified, 16-bit output operations can be used (for example, OUT, DX, AX), as the data sequence is conventional Intel low/high byte.

## Programming Examples

---

The following example shows how to output data in BASIC. The example is in BASIC but translates readily into other programming languages. Since the DACs have 12-bit resolution, data D should be in the range 0 to 4095 decimal. First, split the data into the two bytes DL% (low) and DH% (high), as follows:

```
05 DH% = INT(D/16)           'Generate high byte
10 DL% = D - 16*DH%         'Derive remainder in low byte
20 DL% = 16* DL%            'Shift low nibble four places
30                          ' left
```

Next write the data to the DAC. The example uses DAC 0 with a base address of 300h.

```
40 OUT &H300, DL%           'Low byte
50 OUT &H301, DH%           'High byte and load
```

An assembly language routine is even simpler. Assume AX contains the data and DX has the base address. Use the following statements to write to DAC 0:

```
MOV CL,4                    ;Set up for four left shifts
SAL AX,CL                   ;Left justify data
OUT DX,AX                   'Write to DAC 0
```

# 7

## Calibration

Your DAC-02 board is initially calibrated at the factory. You are advised to check the calibration of a board periodically. For laboratory environments, a 6-month to 1-year calibration interval is recommended. For extremes of temperature, vibration, and humidity, a 3-month calibration interval is recommended. This chapter provides the information you need to calibrate a DAC-02 board.

### Equipment Requirements

---

The equipment requirements for calibrating a DAC-02 board are as follows:

- A digital voltmeter accurate to 6 1/2 digits, such as a Keithley Instruments Model 199
- An STA-U accessory with K-1800 cable or a user-designed interface

### Calibration Program

---

To facilitate calibration, the DAC-02 software package contains a menu-driven calibration and test program (CAL02.EXE). Using this program steps you through all the calibration requirements. Each of the potentiometers shown in the program is clearly marked on the board.

If you are unable to calibrate the board or correct faulty performance, refer to Chapter 8.



# Troubleshooting

If your DAC-02 board is not operating properly, use the information in this chapter to isolate the problem. If the problem appears serious enough to warrant technical support, refer to “Technical Support” on page 8-5 for information on how to contact an applications engineer.

## Problem Isolation

---

If you encounter a problem with a DAC-02 board, use the instructions in this section to isolate the cause of the problem before calling Keithley MetraByte Hardware Applications Engineering.

## Identifying Symptoms and Possible Causes

Use the troubleshooting information in Table 8-1 to try to isolate the problem. Table 8-1 lists general symptoms and possible solutions for problems with DAC-02 boards.

**Table 8-1. Troubleshooting Information**

<b>Symptom</b>	<b>Possible Cause</b>	<b>Possible Solution</b>
Board does not respond	Base address is incorrect or not consistent with what the program is addressing.	Check the base-address-switch setting on the board against the setting shown in the configuration utility. If the base address is set correctly, make sure no other computer device is using any of the I/O locations beginning at the specified base address. If necessary, reconfigure the base address. Refer to page 3-3 for instructions on setting the base address.
	The board is incorrectly aligned in the accessory slot.	Check the board for proper seating.
	The board is damaged.	Contact the Keithley MetraByte Hardware Applications Engineering Department; see page 8-5.
Intermittent operation	The most common cause of this problem is that the I/O bus speed is in excess of 8 MHz.	Reduce I/O bus speed to a maximum of 8 MHz (to change the I/O bus speed, run BIOS setup). See your computer documentation for instructions on running BIOS setup.
	Vibrations or loose connections exist.	Cushion source of vibration and tighten connections.
	The board is overheating.	Check environmental and ambient temperature. See the documentation for your computer.
	Electrical noise exists.	Provide better shielding or reroute unshielded wiring.

**Table 8-1. Troubleshooting Information (cont.)**

<b>Symptom</b>	<b>Possible Cause</b>	<b>Possible Solution</b>
Output voltage does not match input data	The most common cause of this problem is that the I/O bus speed is in excess of 8 MHz.	Reduce I/O bus speed to a maximum of 8 MHz (to change the I/O bus speed, run BIOS setup). See the documentation for your computer for instructions on running BIOS setup.
	An open connection exists.	Check wiring to screw terminal.
	Another system resource is using the specified base address.	Reconfigure the base address of the DAC-02 board; refer to page 3-3 for more information. Check the I/O assignments of other system resources and reconfigure, if necessary.
Computer does not boot.	Board not seated properly.	Check the installation of the board.
	The base address setting of the DAC-02 board conflicts with that of another system resource.	Check the base address settings of your system resources; each address must be unique.
	The power supply of the host computer is too small to handle all the system resources.	Check the needs of all system resources and obtain a larger power supply.
System lockup	A timing error occurred.	Press <b>[Ctrl] + [Break]</b> .

If your board is not operating properly after using the information in Table 8-1, continue with the next two sections to further isolate the problem.

## Testing the Board and Host Computer

To isolate the problem to the DAC-02 board or to the host computer, perform the following steps:

1. Turn the power to the host computer OFF, and remove power connections to the computer.

---

**Caution:** Removing a board with the power ON can cause damage to your board and/or computer.

---

2. While keeping connections to any accessory intact, unplug the accessory connector or cable from the DAC-02 board.
3. Remove the DAC-02 board from the computer and visually check for damage. If a board is obviously damaged, refer to “Technical Support” on page 8-5 for information on returning the board.
4. With the DAC-02 board out of the computer, check the computer for proper operation. Power up the computer and perform any necessary diagnostics.

At this point, if you have another DAC-02 board that you know is functional, you can test the slot and I/O connections using the instructions in the next section. If you do not have another board, refer to the instructions on page 8-5 before calling Keithley Technical Support.

## Testing the Accessory Slot and I/O Connections

To test the computer accessory slot and the I/O connections, perform the following steps:

1. Remove computer power again, and install a DAC-02 board that you know is functional. Do not make any I/O connections.
2. Turn computer power ON and check operation with the functional board in place. This test checks the computer accessory slot. If you were using more than one DAC-02 board when the problem occurred, use the functional board to test the other slot, as well.

3. If the accessory slots are functional, use the functional board to check the I/O connections. Reconnect and check the operation of the I/O connections, one at a time.
4. If operation fails for an I/O connection, check the individual inputs one at a time for shorts and opens.
5. If operation remains normal to this point, the problem is in the DAC-02 board(s) originally in the computer. If you were using more than one board, try each board one at a time in the computer to determine which is faulty.
6. If you cannot isolate the problem, refer to the next section for instructions on obtaining assistance.

## **Technical Support**

---

Before returning any equipment for repair, call the Keithley Applications Engineering Department at:

**1-888-KEITHLEY**

**Monday - Friday, 8:00 A.M. - 5:00 P.M., Eastern Time**

An applications engineer will help you diagnose and resolve your problem over the telephone.

Please make sure that you have the following information available before you call:

<b>DAC-02 Board Configuration</b>	Model	_____
	Serial #	_____
	Revision code	_____
	Base address setting	_____
	Number of channels	_____
<b>Computer</b>	Manufacturer	_____
	CPU type	_____
	Clock speed (MHz)	_____
	KB of RAM	_____
	Video system	_____
	BIOS type	_____
<b>Operating System</b>	DOS version	_____
	Windows version	_____
	Windows mode	_____
<b>Software package</b>	Name	_____
	Serial #	_____
	Version	_____
	Invoice/Order #	_____
<b>Compiler (if applicable)</b>	Language	_____
	Manufacturer	_____
	Version	_____
<b>Accessories</b>	Type	_____
	Type	_____
	Type	_____
	Type	_____

If a telephone resolution is not possible, the applications engineer will issue you a Return Material Authorization (RMA) number and ask you to return the equipment. Include the RMA number with any documentation regarding the equipment.

When returning equipment for repair, include the following information:

- Your name, address, and telephone number.
- The invoice or order number and date of equipment purchase.
- A description of the problem or its symptoms.
- The RMA number on the **outside** of the package.

Repackage the equipment, using the original anti-static wrapping, if possible, and handling it with ground protection. Ship the equipment to:

Attn: RMA # \_\_\_\_\_  
Repair Department  
Keithley Instruments, Inc.  
28775 Aurora Road  
Cleveland, OH 44139

Telephone 1-888-KEITHLEY  
FAX (440) 248-6168

---

**Notes:** If you are submitting your equipment for repair under warranty, you must include the invoice number and date of purchase.

To enable Keithley Metrabyte to respond as quickly as possible, you must include the RMA number on the outside of the package.

---

# A

## Specifications

This appendix provides specifications for the DAC-02 board.

**Table A-1. DAC-02 Specifications**

<b>Feature</b>	<b>Specification</b>
Channels	2
Resolution	12 bits (1 part in 4096 decimal)
Relative accuracy	1/2 LSB (0.01%) maximum
Differential linearity	1/2 LSB maximum
Fixed reference ranges	0 to 5 V (unipolar) 0 to 10 V (unipolar) $\pm 5$ V (bipolar) $\pm 10$ V (bipolar) 4 to 20 mA current loop
Variable reference ranges	$\pm 10$ V (2- or 4-quadrant)
Reference input resistance	7 k $\Omega$ minimum, 11 k $\Omega$ typical, 20 k $\Omega$ maximum
Voltage output characteristics	Drive current: $\pm 5$ mA minimum  Output impedance: < 0.1 $\Omega$ maximum
4 to 20 mA current loop compliance	8 to 36 V



**Table A-2. Environmental Specifications**

<b>Feature</b>	<b>Specification</b>
Temperature coefficient of gain	$\pm 25$ ppm/ $^{\circ}$ C (with reference) $\pm 5$ ppm/ $^{\circ}$ C (external reference)
Zero drift	$\pm 3$ ppm/ $^{\circ}$ C
Operating temperature range	0 to 70 $^{\circ}$ C
Storage temperature range	-55 to +125 $^{\circ}$ C
Humidity	0 to 95% noncondensing
Weight	4 oz. (120 gm)

**Table A-3. Power Specifications**

<b>Feature</b>	<b>Specification</b>
+5 V supply	75 mA typical; 100 mA maximum
+12 V supply	15 mA typical; 25 mA maximum
-12 V supply	25 mA typical; 35mA maximum
Power dissipation	0.85 W typical

# B

## Connector Pin Assignments

The connection between an external I/O device and a DAC-02 board is made at the main I/O connector, which is a standard 25-pin, D-type male connector. The mating connector is a 25-pin, D-type female connector. Figure B-1 illustrates pin assignments of the main I/O connector.

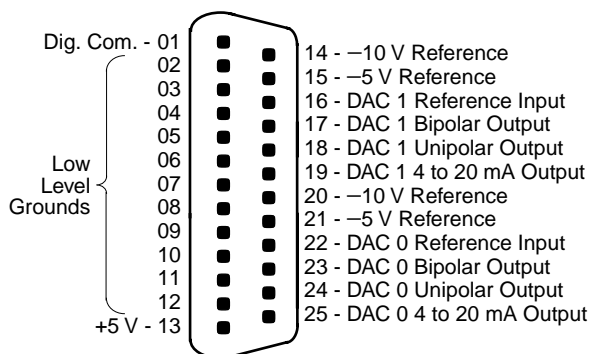

**Figure B-1. Main I/O Connector Pin Assignments**

# Index

## A

accessory, STA-U 1-2  
anti-static wrapping material 3-1  
Applications Engineering Department 8-5  
attaching, STA-U 4-2

## B

base address switch 3-3  
block diagram 2-1

## C

cable, C-1800 1-2  
cabling and wiring 4-1  
calibration utility 1-2, 7-1  
configuration utility 1-2  
connector, 37-pin female type D 1-2  
Control Panel utility 1-2, 5-1

## D

data format 6-2  
diagram, block 2-1

## E

equipment requirements 7-1  
examples, programming 6-3

## F

FILES.TXT 3-2

## I

I/O address map 6-1  
I/O commands 6-1  
installing a DDA-06 board 3-5

## K

K-1800 cable 1-2, 4-2

## L

list, packing 3-2

## M

main I/O connector B-1

## P

packing list 3-2  
pin assignments B-1  
PORTIO.DLL 1-2  
PORTIO.TXT 3-2  
problem isolation 8-1  
programming examples 6-3

## R

- README.TXT 3-2
- register I/O addresses 6-1
- returning equipment 8-6
- RMA 8-6
- RMA number 8-6

## S

- setup panel
  - configuration 5-1
  - multiple point output 5-1
  - single point output 5-1
- software package 1-2, 3-2
- specifications
  - DAC A-1
  - environmental A-2
  - power A-2
- static electricity 3-1
- STA-U accessory 1-2
- switch, base address 3-3
- switch and jumper locations 3-2

## T

- Technical Support 8-5
- troubleshooting 8-1

## U

- unpacking and inspecting 3-1
- utility
  - calibration 1-2
  - configuration 1-2
  - Control Panel 1-2
  - PORTIO.DLL 1-2

## W

- warranty repairs 8-7

Specifications are subject to change without notice.

All Keithley trademarks and trade names are the property of Keithley Instruments, Inc. All other trademarks and trade names are the property of their respective companies.



**Keithley Instruments, Inc.**

28775 Aurora Road • Cleveland, Ohio 44139 • 440-248-0400 • Fax: 440-248-6168  
1-888-KEITHLEY (534-8453) • [www.keithley.com](http://www.keithley.com)

**Sales Offices:** **BELGIUM:**

Bergensesteenweg 709 • B-1600 Sint-Pieters-Leeuw • 02-363 00 40 • Fax: 02/363 00 64

**CHINA:**

Yuan Chen Xin Building, Room 705 • 12 Yumin Road, Dewai, Madian • Beijing 100029 • 8610-6202-2886 • Fax: 8610-6202-2892

**FINLAND:**

Tietäjantie 2 • 02130 Espoo • Phone: 09-54 75 08 10 • Fax: 09-25 10 51 00

**FRANCE:**

3, allée des Garays • 91127 Palaiseau Cédex • 01-64 53 20 20 • Fax: 01-60 11 77 26

**GERMANY:**

Landsberger Strasse 65 • 82110 Germering • 089/84 93 07-40 • Fax: 089/84 93 07-34

**GREAT BRITAIN:**

Unit 2 Commerce Park, Brunel Road • Theale • Berkshire RG7 4AB • 0118 929 7500 • Fax: 0118 929 7519

**INDIA:**

Flat 2B, Willocrissa • 14, Rest House Crescent • Bangalore 560 001 • 91-80-509-1320/21 • Fax: 91-80-509-1322

**ITALY:**

Viale San Gimignano, 38 • 20146 Milano • 02-48 39 16 01 • Fax: 02-48 30 22 74

**JAPAN:**

New Pier Takeshiba North Tower 13F • 11-1, Kaigan 1-chome • Minato-ku, Tokyo 105-0022 • 81-3-5733-7555 • Fax: 81-3-5733-7556

**KOREA:**

2FL., URI Building • 2-14 Yangjae-Dong • Seocho-Gu, Seoul 137-888 • 82-2-574-7778 • Fax: 82-2-574-7838

**NETHERLANDS:**

Postbus 559 • 4200 AN Gorinchem • 0183-635333 • Fax: 0183-630821

**SWEDEN:**

c/o Regus Business Centre • Frosundaviks Allé 15, 4tr • 169 70 Solna • 08-509 04 679 • Fax: 08-655 26 10

**SWITZERLAND:**

Kriesbachstrasse 4 • 8600 Dübendorf • 01-821 94 44 • Fax: 01-820 30 81

**TAIWAN:**

1FL., 85 Po Ai Street • Hsinchu, Taiwan, R.O.C. • 886-3-572-9077 • Fax: 886-3-572-9031