

KEITHLEY

Model 2520 Pulsed Laser Diode Test System

Service Manual

A GREATER MEASURE OF CONFIDENCE

WARRANTY

Keithley Instruments, Inc. warrants this product to be free from defects in material and workmanship for a period of 1 year from date of shipment.

Keithley Instruments, Inc. warrants the following items for 90 days from the date of shipment: probes, cables, rechargeable batteries, diskettes, and documentation.

During the warranty period, we will, at our option, either repair or replace any product that proves to be defective.

To exercise this warranty, write or call your local Keithley representative, or contact Keithley headquarters in Cleveland, Ohio. You will be given prompt assistance and return instructions. Send the product, transportation prepaid, to the indicated service facility. Repairs will be made and the product returned, transportation prepaid. Repaired or replaced products are warranted for the balance of the original warranty period, or at least 90 days.

LIMITATION OF WARRANTY

This warranty does not apply to defects resulting from product modification without Keithley's express written consent, or misuse of any product or part. This warranty also does not apply to fuses, software, non-rechargeable batteries, damage from battery leakage, or problems arising from normal wear or failure to follow instructions.

THIS WARRANTY IS IN LIEU OF ALL OTHER WARRANTIES, EXPRESSED OR IMPLIED, INCLUDING ANY IMPLIED WARRANTY OF MERCHANTABILITY OR FITNESS FOR A PARTICULAR USE. THE REMEDIES PROVIDED HEREIN ARE BUYER'S SOLE AND EXCLUSIVE REMEDIES.

NEITHER KEITHLEY INSTRUMENTS, INC. NOR ANY OF ITS EMPLOYEES SHALL BE LIABLE FOR ANY DIRECT, INDIRECT, SPECIAL, INCIDENTAL OR CONSEQUENTIAL DAMAGES ARISING OUT OF THE USE OF ITS INSTRUMENTS AND SOFTWARE EVEN IF KEITHLEY INSTRUMENTS, INC., HAS BEEN ADVISED IN ADVANCE OF THE POSSIBILITY OF SUCH DAMAGES. SUCH EXCLUDED DAMAGES SHALL INCLUDE, BUT ARE NOT LIMITED TO: COSTS OF REMOVAL AND INSTALLATION, LOSSES SUSTAINED AS THE RESULT OF INJURY TO ANY PERSON, OR DAMAGE TO PROPERTY.



Keithley Instruments, Inc. • 28775 Aurora Road • Cleveland, OH 44139 • 440-248-0400 • Fax: 440-248-6168 • <http://www.keithley.com>

BELGIUM:

Keithley Instruments B.V.

Bergensesteenweg 709 • B-1600 Sint-Pieters-Leeuw • 02/363 00 40 • Fax: 02/363 00 64

CHINA:

Keithley Instruments China

Yuan Chen Xin Building, Room 705 • 12 Yumin Road, Dewai, Madian • Beijing 100029 • 8610-62022886 • Fax: 8610-62022892

FRANCE:

Keithley Instruments Sarl

3, allée des Garays • 91127 Palaiseau Cedex • 01-64 53 20 20 • Fax: 01-60 11 77 26

GERMANY:

Keithley Instruments GmbH

Landsberger Strasse 65 • 82110 Germering • 089/84 93 07-40 • Fax: 089/84 93 07-34

GREAT BRITAIN:

Keithley Instruments Ltd

Unit 2 Commerce Park, Brunel Road • Theale • Reading • Berkshire RG7 4AB • 0118 929 7500 • Fax: 0118 929 7519

INDIA:

Keithley Instruments GmbH

Flat 2B, WILOCRISSA • 14, Rest House Crescent • Bangalore 560 001 • 91-80-509-1320/21 • Fax: 91-80-509-1322

ITALY:

Keithley Instruments s.r.l.

Viale S. Gimignano, 38 • 20146 Milano • 02-48 39 16 01 • Fax: 02-48 30 22 74

NETHERLANDS:

Keithley Instruments B.V.

Postbus 559 • 4200 AN Gorinchem • 0183-635333 • Fax: 0183-630821

SWITZERLAND:

Keithley Instruments SA

Kriesbachstrasse 4 • 8600 Dübendorf • 01-821 94 44 • Fax: 01-820 30 81

TAIWAN:

Keithley Instruments Taiwan

1 Fl. 85 Po Ai Street • Hsinchu, Taiwan, R.O.C. • 886-3572-9077 • Fax: 886-3572-9030

Model 2520
Pulsed Laser Diode Test System
Service Manual

©2001, Keithley Instruments, Inc.
All rights reserved.
Cleveland, Ohio, U.S.A.
First Printing, September 2001
Document Number: 2520-902-01 Rev. A

Manual Print History

The print history shown below lists the printing dates of all Revisions and Addenda created for this manual. The Revision Level letter increases alphabetically as the manual undergoes subsequent updates. Addenda, which are released between Revisions, contain important change information that the user should incorporate immediately into the manual. Addenda are numbered sequentially. When a new Revision is created, all Addenda associated with the previous Revision of the manual are incorporated into the new Revision of the manual. Each new Revision includes a revised copy of this print history page.

Revision A (Document Number 2520-902-01) September 2001

Safety Precautions

The following safety precautions should be observed before using this product and any associated instrumentation. Although some instruments and accessories would normally be used with non-hazardous voltages, there are situations where hazardous conditions may be present.

This product is intended for use by qualified personnel who recognize shock hazards and are familiar with the safety precautions required to avoid possible injury. Read the operating information carefully before using the product.

The types of product users are:

Responsible body is the individual or group responsible for the use and maintenance of equipment, for ensuring that the equipment is operated within its specifications and operating limits, and for ensuring that operators are adequately trained.

Operators use the product for its intended function. They must be trained in electrical safety procedures and proper use of the instrument. They must be protected from electric shock and contact with hazardous live circuits.

Maintenance personnel perform routine procedures on the product to keep it operating, for example, setting the line voltage or replacing consumable materials. Maintenance procedures are described in the manual. The procedures explicitly state if the operator may perform them. Otherwise, they should be performed only by service personnel.

Service personnel are trained to work on live circuits, and perform safe installations and repairs of products. Only properly trained service personnel may perform installation and service procedures.

Keithley products are designed for use with electrical signals that are rated Installation Category I and Installation Category II, as described in the International Electrotechnical Commission (IEC) Standard IEC 60664. Most measurement, control, and data I/O signals are Installation Category I and must not be directly connected to mains voltage or to voltage sources with high transient over-voltages. Installation Category II connections require protection for high transient over-voltages often associated with local AC mains connections. The user should assume all measurement, control, and data I/O connections are for connection to Category I sources unless otherwise marked or described in the Manual.

Exercise extreme caution when a shock hazard is present. Lethal voltage may be present on cable connector jacks or test fixtures. The American National Standards Institute (ANSI) states that a shock hazard exists when voltage levels greater than 30V RMS, 42.4V peak, or 60VDC are present. **A good safety practice is to expect that hazardous voltage is present in any unknown circuit before measuring.**

Users of this product must be protected from electric shock at all times. The responsible body must ensure that users are prevented access and/or insulated from every connection point. In some cases, connections must be exposed to potential human contact. Product users in these circumstances must be trained to protect themselves from the risk of electric shock. If the circuit is capable of operating at or above 1000 volts, **no conductive part of the circuit may be exposed.**

Do not connect switching cards directly to unlimited power circuits. They are intended to be used with impedance limited sources. NEVER connect switching cards directly to AC mains. When connecting sources to switching cards, install protective devices to limit fault current and voltage to the card.

Before operating an instrument, make sure the line cord is connected to a properly grounded power receptacle. Inspect the connecting cables, test leads, and jumpers for possible wear, cracks, or breaks before each use.

When installing equipment where access to the main power cord is restricted, such as rack mounting, a separate main input power disconnect device must be provided, in close proximity to the equipment and within easy reach of the operator.

For maximum safety, do not touch the product, test cables, or any other instruments while power is applied to the circuit under test. ALWAYS remove power from the entire test system and discharge any capacitors before: connecting or disconnecting cables or jumpers, installing or removing switching cards, or making internal changes, such as installing or removing jumpers.

Do not touch any object that could provide a current path to the common side of the circuit under test or power line (earth) ground. Always make measurements with dry hands while standing on a dry, insulated surface capable of withstanding the voltage being measured.

The instrument and accessories must be used in accordance with its specifications and operating instructions or the safety of the equipment may be impaired.

Do not exceed the maximum signal levels of the instruments and accessories, as defined in the specifications and operating information, and as shown on the instrument or test fixture panels, or switching card.

When fuses are used in a product, replace with same type and rating for continued protection against fire hazard.

Chassis connections must only be used as shield connections for measuring circuits, NOT as safety earth ground connections.

If you are using a test fixture, keep the lid closed while power is applied to the device under test. Safe operation requires the use of a lid interlock.

If a  screw is present, connect it to safety earth ground using the wire recommended in the user documentation.

The  symbol on an instrument indicates that the user should refer to the operating instructions located in the manual.

The  symbol on an instrument shows that it can source or measure 1000 volts or more, including the combined effect of normal and common mode voltages. Use standard safety precautions to avoid personal contact with these voltages.

The **WARNING** heading in a manual explains dangers that might result in personal injury or death. Always read the associated information very carefully before performing the indicated procedure.

The **CAUTION** heading in a manual explains hazards that could damage the instrument. Such damage may invalidate the warranty.

Instrumentation and accessories shall not be connected to humans.

Before performing any maintenance, disconnect the line cord and all test cables.

To maintain protection from electric shock and fire, replacement components in mains circuits, including the power transformer, test leads, and input jacks, must be purchased from Keithley Instruments. Standard fuses, with applicable national safety approvals, may be used if the rating and type are the same. Other components that are not safety related may be purchased from other suppliers as long as they are equivalent to the original component. (Note that selected parts should be purchased only through Keithley Instruments to maintain accuracy and functionality of the product.) If you are unsure about the applicability of a replacement component, call a Keithley Instruments office for information.

To clean an instrument, use a damp cloth or mild, water based cleaner. Clean the exterior of the instrument only. Do not apply cleaner directly to the instrument or allow liquids to enter or spill on the instrument. Products that consist of a circuit board with no case or chassis (e.g., data acquisition board for installation into a computer) should never require cleaning if handled according to instructions. If the board becomes contaminated and operation is affected, the board should be returned to the factory for proper cleaning/servicing.

Table of Contents

1	Performance Verification	
	Introduction	1-2
	Verification test requirements	1-4
	Environmental conditions	1-4
	Warm-up period	1-4
	Line power	1-4
	Recommended test equipment	1-5
	Resistor characterization	1-5
	Verification limits	1-6
	Example limits calculation	1-6
	Restoring factory defaults	1-6
	Performing the verification test procedures	1-7
	Test summary	1-7
	Test considerations	1-7
	Testhead connections	1-8
	Voltage measurement accuracy	1-9
	Current source accuracy	1-10
	Current measurement accuracy	1-11
	Voltage bias source accuracy	1-13
2	Calibration	
	Introduction	2-2
	Environmental conditions	2-4
	Temperature and relative humidity	2-4
	Warm-up period	2-4
	Line power	2-4
	Calibration considerations	2-4
	Calibration cycle	2-5
	Recommended calibration equipment	2-5
	Resistor characterization	2-5
	Calibration menus	2-6
	Unlocking calibration	2-7
	Unlocking calibration from the front panel	2-7
	Unlocking calibration by remote	2-7
	Changing the password	2-8
	Changing the password from the front panel	2-8
	Changing the password by remote	2-8

Resetting the calibration password	2-8
Viewing calibration dates and calibration count	2-9
Calibration errors	2-9
Front panel error reporting	2-9
Remote error reporting	2-9
Aborting calibration steps	2-9
Testhead connections	2-10
Front panel calibration	2-10
Remote calibration	2-22
Remote calibration command summary	2-22
Remote calibration procedure	2-23

3 Routine Maintenance

Introduction	3-2
Line fuse replacement	3-2

4 Troubleshooting

Introduction	4-2
Safety considerations	4-2
Repair considerations	4-2
Power-on self-test	4-2
Front panel tests	4-3
KEYS test	4-3
DISPLAY PATTERNS test	4-3
CHAR SET test	4-4
Principles of operation	4-4
Overall block diagram	4-4
Analog circuits	4-6
Power supply	4-9
Digital circuitry	4-10
Troubleshooting	4-12
Display board checks	4-12
Power supply checks	4-13
Digital circuitry checks	4-14
Analog circuitry checks	4-15
No comm link error	4-16

5	Disassembly	
	Introduction	5-2
	Handling and cleaning	5-2
	Handling PC boards	5-2
	Solder repairs	5-2
	Static sensitive devices	5-3
	Assembly drawings	5-3
	Case cover removal	5-4
	Motherboard removal	5-4
	Front panel disassembly	5-5
	Removing power components	5-6
	Power supply module removal	5-6
	Power module removal	5-6
	Instrument re-assembly	5-6
	Testhead disassembly	5-7
	Case disassembly	5-7
	Output board removal	5-7
	Input board removal	5-7
	Testhead re-assembly	5-7
6	Replaceable Parts	
	Introduction	6-2
	Parts lists	6-2
	Ordering information	6-2
	Factory service	6-2
	Component layouts	6-2
A	Specifications	

B**Calibration Reference**

Introduction	B-2
Command summary	B-2
Miscellaneous commands	B-3
Measurement commands	B-6
Current source commands	B-7
Voltage bias source commands	B-8
Detecting calibration errors	B-9
Reading the error queue	B-9
Error summary	B-9
Status byte EAV (Error Available) bit	B-10
Generating an SRQ on error	B-10
Detecting calibration step completion	B-10
Using the *OPC? query	B-10
Using the *OPC command	B-11
Generating an SRQ on calibration complete	B-11

List of Illustrations

1 Performance Verification

Figure 1-1	Testhead connections	1-8
Figure 1-2	Connections for voltage measurement verification tests	1-9
Figure 1-3	Connections for current source verification tests	1-10
Figure 1-4	Connections for DETECTOR 1 current measurement verification tests	1-11
Figure 1-5	Connections for DETECTOR 2 current measurement verification tests	1-13
Figure 1-6	Connections for DETECTOR 1 voltage bias source verification tests	1-13
Figure 1-7	Connections for DETECTOR 2 voltage bias source verification tests	1-14

2 Calibration

Figure 2-1	Testhead connections	2-10
Figure 2-2	Voltage measurement calibration connections	2-12
Figure 2-3	Current source calibration connections	2-13
Figure 2-4	Pulse low calibration connections	2-15
Figure 2-5	Detector 1 voltage bias source calibration connections	2-16
Figure 2-6	Detector 2 voltage bias source calibration connections	2-17
Figure 2-7	Detector 1 current measurement calibration connections	2-18
Figure 2-8	Detector 2 current measurement calibration connections	2-19
Figure 2-9	Compliance calibration connections	2-20

3 Routine Maintenance

Figure 3-1	Model 2520 rear panel	3-2
------------	-----------------------------	-----

4 Troubleshooting

Figure 4-1	Overall block diagram	4-5
Figure 4-2	Analog circuitry block diagram	4-7
Figure 4-3	Power supply block diagram	4-9
Figure 4-4	Digital circuitry block diagram	4-11

List of Tables

1	Performance Verification	
Table 1-1	Recommended verification equipment	1-5
Table 1-2	Voltage measurement accuracy limits	1-9
Table 1-3	Current source verification limits	1-11
Table 1-4	Current measurement verification limits	1-12
2	Calibration	
Table 2-1	Recommended calibration equipment	2-5
Table 2-2	Calibration menu	2-6
Table 2-3	Calibration execution menu	2-6
Table 2-4	Voltage measurement calibration values	2-11
Table 2-5	Current source calibration values	2-13
Table 2-6	Pulse low calibration values	2-14
Table 2-7	Current measurement calibration values	2-18
Table 2-8	Remote calibration command summary	2-22
Table 2-9	Voltage measurement calibration voltages and commands .	2-25
Table 2-10	Remote current source calibration summary	2-27
Table 2-11	Remote pulse low calibration summary	2-29
Table 2-12	Remote voltage bias source calibration summary	2-31
Table 2-13	Remote current measurement calibration currents and commands	2-33
Table 2-14	Remote compliance calibration summary	2-36
3	Routine Maintenance	
Table 3-1	Power line fuse	3-3
4	Troubleshooting	
Table 4-1	Display board checks	4-12
Table 4-2	Power supply checks	4-13
Table 4-3	Digital circuitry checks	4-14
Table 4-4	Analog circuitry checks	4-15

6

Replaceable Parts

Table 6-1	Mainframe digital board parts list	6-3
Table 6-2	Mainframe display board parts list	6-9
Table 6-3	Test head board parts list	6-10
Table 6-4	Pulse board parts list	6-13
Table 6-5	Miscellaneous parts list	6-16

B

Calibration Reference

Table B-1	Calibration commands	B-2
Table B-2	Calibration errors	B-9

1

Performance Verification

Introduction

Use the procedures in this section to verify that Model 2520 Pulsed Laser Diode Test System accuracy is within the limits stated in the instrument's one-year accuracy specifications. You can perform these verification procedures:

- When you first receive the instrument to make sure that it was not damaged during shipment.
- To verify that the unit meets factory specifications.
- To determine if calibration is required.
- Following calibration to make sure it was performed properly.

WARNING While the Model 2520 does not incorporate a laser, it is designed to operate (power) laser diode devices. Read all safety precautions listed at the beginning of the Model 2520 User's Manual. The following safety practices must be used to protect operators and other users of this product from potential exposure to laser radiation:

- Operators must be protected from radiation and electrical hazards at all times.
- The installer must comply with all applicable laws and regulations on laser safety. This requirement includes warning signs and operator training.
- The interlock is required for safe operation. The test fixtures must ensure that the interlock circuit is disabled (source outputs inhibited) so that an operator is not exposed to any radiation. The test fixture interlock must not be defeated.
- The testhead key control must be used to prevent operation unless authorized by the responsible body. This requirement must be part of the facilities administrative controls for laser safety. Outputs cannot be turned on with the key removed.
- When servicing the test system, any required personnel protection equipment (e.g. laser safety goggles) must be provided by the customer's responsible body.
- The customer's laser safety officer (LSO) must review and approve all installations before they are put into operation. Any safety concerns must be immediately reported to the customer's LSO.
- If at any time, the indicators provided on the testhead for INTERLOCK STATUS or LASER POWER ON should fail to light or properly indicate status, immediately contact a Keithley service representative for repair. Failure to do so may expose the user to hazards without proper warnings. See "Interlock status indicator test sequence" in Section 9 of the User's manual for details on testing the indicator lights.
- Maximum isolation from earth ground is 10V. Exceeding this value may result in a shock hazard.
- When making connections, do not leave any exposed connections. Ensure that all external circuits are properly insulated.

NOTE *If the instrument is still under warranty and its performance is outside specified limits, contact your Keithley representative or the factory to determine the correct course of action.*

Verification test requirements

Be sure that you perform the verification tests:

- Under the proper environmental conditions.
- After the specified warm-up period.
- Using the correct line voltage.
- Using the proper test equipment.
- Using the specified output signals and reading limits.

Environmental conditions

Conduct your performance verification procedures in a test environment with:

- An ambient temperature of 18-28°C (65-82°F).
- A relative humidity of less than 70% unless otherwise noted.

Warm-up period

Allow the Model 2520 to warm up for a minimum of one hour before conducting the verification procedures.

If the instrument has been subjected to temperature extremes (those outside the ranges stated above), allow additional time for the instrument's internal temperature to stabilize. Typically, allow one extra hour to stabilize a unit that is 10°C (18°F) outside the specified temperature range.

Also, allow the test equipment to warm up for the minimum time specified by the manufacturer.

Line power

The Model 2520 requires a line voltage of 100V to 240V and a line frequency of 50 or 60 Hz. Verification tests must be performed within this range.

Recommended test equipment

Table 1-1 summarizes recommended verification equipment and pertinent specifications. You can use alternate equipment as long as that equipment has specifications at least as good as those listed in **Table 1-1**. Keep in mind, however, that test equipment uncertainty will add to the uncertainty of each measurement. Generally, test equipment uncertainty should be at least four times better than corresponding Model 2520 specifications.

Table 1-1
Recommended verification equipment

Description	Manufacturer/Model	Specifications
Calibrator	Fluke 5700A ¹	DC Voltage: 5V: ±5ppm 10V: ±5ppm
Digital Multimeter	Keithley 2001 ²	DC Voltage: 20V: ±22ppm Resistance: 20Ω ±59ppm 200Ω ±43ppm 2kΩ ±37ppm
Precision Resistors ³		1.2 to 1.6Ω, 5W, ±5% ⁴ 10 to 15Ω, 5W, ±5% ⁴ 200Ω, 2W, ±1% 400Ω, 1W, ±1% 1kΩ, 0.5W, ±1% 2kΩ, 0.25W, ±1% Temperature coefficient = 20ppm/°C for all resistors

1. 90-day accuracy specifications of lowest usable range for specified output.
2. 90-day full-range accuracy specifications.
3. Characterize resistors to within ±100ppm using 4-wire ohms function of digital multimeter before use.
4. Use only non-inductive metal film or bulk metal resistors.

Resistor characterization

The precision resistors listed in **Table 1-1** should be characterized to within ±100ppm using the 4-wire ohms function of the digital multimeter before use. Use the characterized values when performing the verification procedure.

Verification limits

The verification limits listed in this section have been calculated using only the Model 2520 one-year accuracy specifications; they do not include test equipment uncertainty. If a particular measurement falls outside the allowable range, recalculate new limits based on Model 2520 specifications and corresponding test equipment specifications.

Example limits calculation

As an example of how verification limits are calculated, assume you are testing the 10mA measurement range with a 10mA input current. Using the Model 2520 one-year accuracy specification of $\pm(0.3\%$ of reading $+ 20\mu\text{A}$ offset), the calculated reading limits are:

$$\text{Limits} = 10\text{mA} \pm [(10\text{mA} \times 0.3\%) + 20\mu\text{A}]$$

$$\text{Limits} = 10\text{mA} \pm (30\mu\text{A} + 20\mu\text{A})$$

$$\text{Limits} = 10\text{mA} \pm 50\mu\text{A}$$

$$\text{Limits} = 9.95\text{mA to } 10.05\text{mA}$$

Restoring factory defaults

Before performing the verification procedures, restore the instrument to its factory front panel (BENCH) defaults as follows:

1. Press the SETUP key. The instrument will display the following prompt:
SAVESETUP MENU
SAVE RESTORE POWERON RESET
2. Select RESET, then press ENTER. The unit displays:
RESET ORIGINAL DFLTS
BENCH GPIB
3. Select BENCH, then press ENTER to restore BENCH defaults.

Performing the verification test procedures

Test summary

- Detector current measurement accuracy
- Laser diode voltage measurement accuracy
- Laser diode current source accuracy
- Detector voltage bias source accuracy

If the Model 2520 is not within specifications and not under warranty, see the calibration procedures in Section 2, Calibration, for information on calibrating the unit.

Test considerations

When performing the verification procedures:

- Restore factory front panel defaults as previously outlined.
- Ensure test equipment is fully warmed up and properly connected to the correct Model 2520 terminals as required.
- Allow signals to settle before making a measurement.
- Do not connect test equipment to the Model 2520 through a scanner, multiplexer, or other switching equipment.

WARNING The maximum common-mode voltage (voltage between LO and chassis ground) is $\pm 10\text{V DC}$. Exceeding this value may cause a shock hazard.

Testhead connections

The Model 2520 mainframe must be connected to the testhead in order to perform the verification procedures. Using [Figure 1-1](#) as a guide, make testhead connections as follows:

CAUTION Make sure power is turned off before making connections.

- Connect mainframe TESTHEAD CONN 1 to testhead MAINFRAME CONN 1.
- Connect mainframe TESTHEAD CONN 2 to testhead MAINFRAME CONN 2.
- Short pins 1 and 9 of the REMOTE INTERLOCK connector. Insert the key in the KEY INTERLOCK and rotate to the ENABLED position to enable operation.

WARNING Shorting the interlock connector will disable the interlocks. Use caution when performing verification tests.

NOTE Both interlocks must be enabled to perform the verification tests.

Figure 1-1
Testhead connections

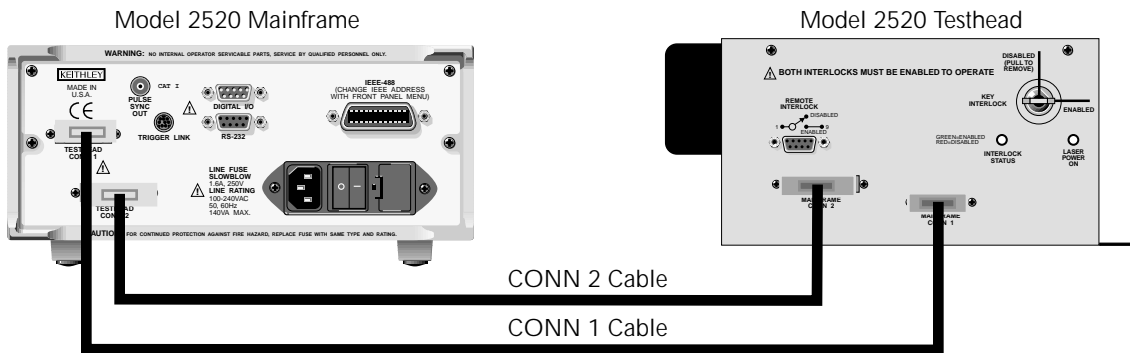

Voltage measurement accuracy

Follow the steps below to verify that Model 2520 laser diode voltage measurement accuracy is within specified limits. This test involves applying accurate voltages from a DC calibrator, and verifying that the Model 2520 voltage readings are within specified limits.

1. With the power off, connect the voltage calibrator to the testhead VOLTAGE SENSE jacks, as shown in Figure 1-2.
2. Turn on the Model 2520 and calibrator, and allow them to warm up for a minimum of one hour.
3. Restore BENCH defaults as covered previously in *Restoring factory defaults*.
4. Press the LASER V_L key, then select the Model 2520 5V range with the RANGE \blacktriangledown key.
5. Set the calibrator source voltage to +5.0000V, and turn on the output.
6. Press the TRIG key, then verify the Model 2520 voltage reading is within the limits for the 5V range shown in Table 1-2.
7. Repeat steps 4 through 6 for the 10V range with a 10V input voltage, as covered in Table 1-2.

Table 1-2
Voltage measurement accuracy limits

Model 2520 range	Calibrator voltage	Voltage reading limits (1 year, 18°C to 28°C)
5V	5.0000V	4.9785 to 5.0215V
10V	10.000V	9.962 to 10.038V

Figure 1-2
Connections for voltage measurement verification tests

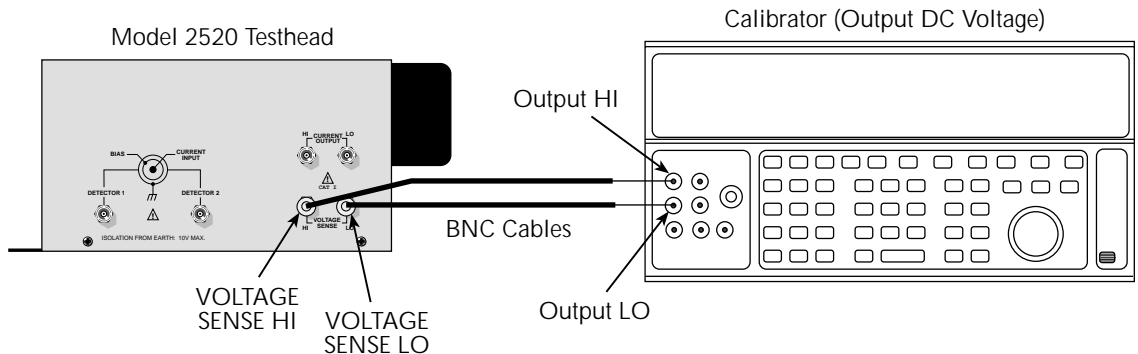

Current source accuracy

Follow the steps below to verify that Model 2520 current source accuracy is within specified limits. This test involves setting the output current to a specific value and measuring the current with a digital multimeter.

1. With the power off, connect the digital multimeter and characterized 10Ω to 15Ω resistor to the testhead CURRENT OUTPUT jacks, as shown in Figure 1-3.
2. Turn on the Model 2520 and DMM, and allow them to warm up for a minimum of one hour.
3. Restore front panel (BENCH) defaults as outlined previously in *Restoring factory defaults*.
4. Select the DC mode as follows:
 - a. Press CONFIG then LASER I_L .
 - b. Select SHAPE, then press ENTER.
 - c. Select DC, then press ENTER.
 - d. Press EXIT to return to normal display.
5. Press the LASER I_L key, then the EDIT key, and select the Model 2520 500mA source range with the RANGE \blacktriangledown key.
6. Select the DMM DC voltage function, and enable auto-range.
7. Press the EDIT key to enter the EDIT mode. Using the EDIT \blacktriangle and \blacktriangledown or numeric keys, set the Model 2520 current source output to 500.00mA, then turn on the outputs by pressing the ON/OFF OUTPUT key.
8. Note the DMM voltage reading, then turn off the output by pressing the ON/OFF OUTPUT key.

Figure 1-3
Connections for current source verification tests

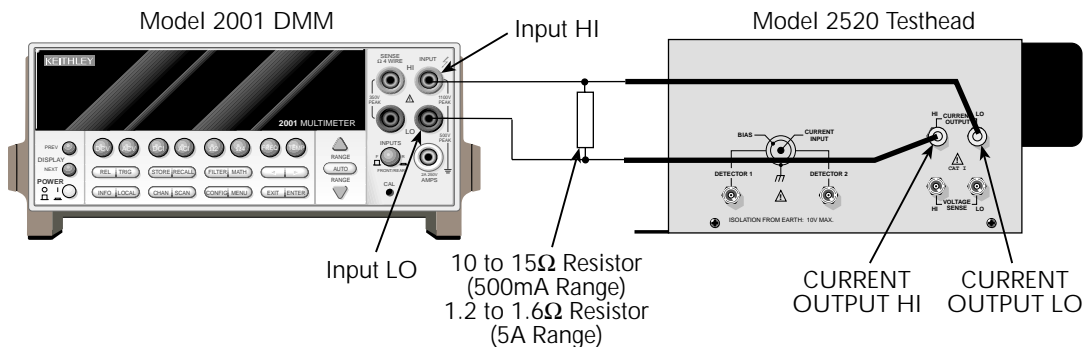

9. Calculate the current using the voltage value and characterized resistance value: $I = V/R$. Recalculate reading limits from these values, then verify that the current is within those limits.
10. Replace the 10Ω to 15Ω resistor with the characterized 1.2Ω to 1.6Ω resistor.
11. Repeat steps 5 through 9 for the 5A range using the 1A value shown in [Table 1-3](#).

Table 1-3
Current source verification limits

Model 2520 range	Test resistance	Output current	Output current limits* (1 year, 18°C to 28°C)
500mA	10 to 15Ω	500.000mA	498.55mA to 501.45mA
5A	1.2 to 1.6Ω	1.0000A	0.9935 to 1.0065A

* Nominal values. Recalculate limits from characterized resistance and measured voltage: $I = V/R$.

Current measurement accuracy

Follow the steps below to verify that Model 2520 detector current measurement accuracy is within specified limits. This test involves applying currents and verifying that Model 2520 current readings are within required limits.

1. With the power off, connect the 2kΩ resistor and DMM to the testhead DETECTOR 1 jack, as shown in [Figure 1-4](#).
2. Turn on the Model 2520 and DMM, and allow them to warm up for a minimum of one hour.
3. Select the DMM DC volts function, and enable auto-range.

Figure 1-4
Connections for DETECTOR 1 current measurement verification tests

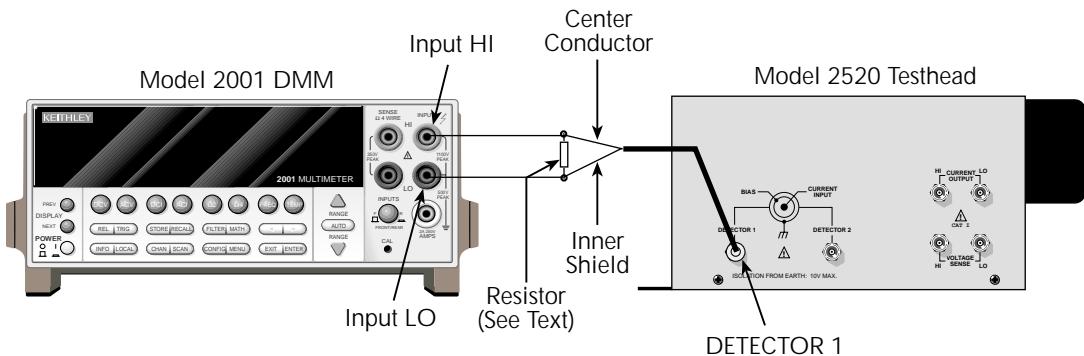

4. Restore front panel (BENCH) defaults as outlined previously in *Restoring factory defaults*.
5. Press the DETECTOR 1 I_{PD} key, then select the Model 2520 10mA range with the RANGE ▼ key.
6. Press the DETECTOR 1 VB key, then press the EDIT key, and set the voltage bias source value to +20.000V.
7. Turn on the Model 2520 outputs by pressing the ON/OFF OUTPUT key.
8. Press the TRIG key. Note the DMM voltage reading, then turn off the outputs by pressing the ON/OFF OUTPUT key.
9. Calculate the current from the DMM voltage reading and characterized resistance value: $I = V/R$.
10. Calculate reading limits based on the current and Model 2520 specifications, then verify that the Model 2520 DETECTOR 1 current reading is within the limits.
11. Repeat steps 5 through 10 for the 20mA, 50mA, and 100mA ranges. Be sure to use the correct test resistor for each range.
12. After verifying all ranges for DETECTOR 1, repeat the entire procedure for DETECTOR 2. (Connect the calibrator to the TESTHEAD DETECTOR 2 jack, and select that channel by pressing DETECTOR 2 I_{PD}. See [Figure 1-5](#) for connections.)

Table 1-4

Current measurement verification limits

Model 2520 range	Test resistor	Reading limits* (1 year, 18°C to 28°C)
10mA	2kΩ	9.950 to 10.050mA
20mA	1kΩ	19.875 to 20.125mA
50mA	400Ω	49.760 to 50.240mA
100mA	200Ω	99.53 to 100.47mA

*Nominal values. Recalculate limits from characterized resistance and measured voltage: $I = V/R$.

Figure 1-5
Connections for DETECTOR 2 current measurement verification tests

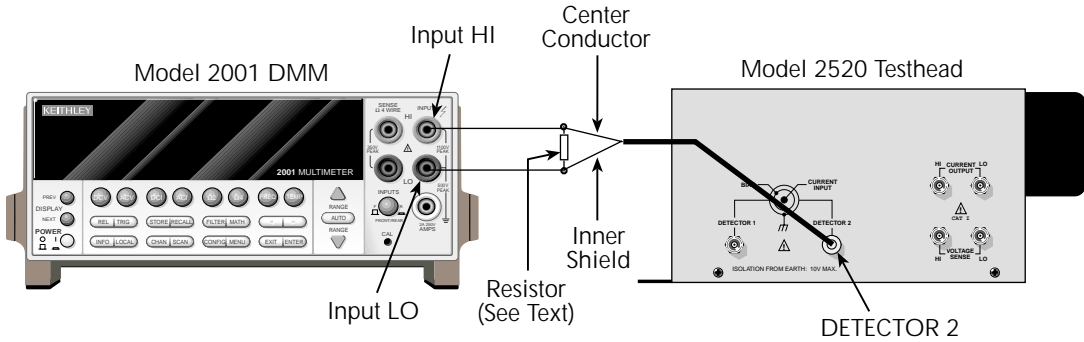

Voltage bias source accuracy

Follow the steps below to verify that Model 2520 detector voltage bias source accuracy is within specified limits. This test involves setting the bias voltages to specific values and measuring the voltages with a DMM.

1. With the power off, connect the digital multimeter to the Model 2520 testhead DETECTOR 1 jack, as shown in Figure 1-6.
2. Turn on the Model 2520 and DMM, and allow them to warm up for a minimum of one hour.
3. Restore BENCH defaults as covered previously in *Restoring factory defaults*.
4. Select the DMM DC volts measuring function, and choose auto-range.

Figure 1-6
Connections for DETECTOR 1 voltage bias source verification tests

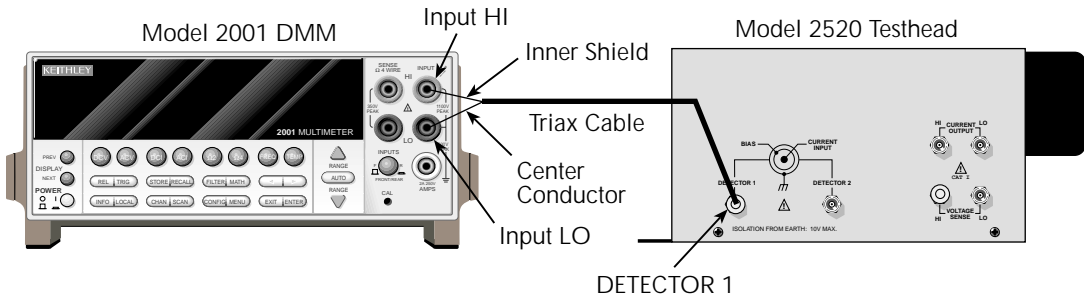

5. Press the DETECTOR 1 V_B key, press EDIT, then set the source voltage to +20.000V using the EDIT ▲ and ▼ or numeric keys.
6. Press the ON/OFF OUTPUT key to turn on the outputs, then press TRIG.
7. Verify the DMM reading is within the following limits: 19.75 to 20.25V.
8. Press the ON/OFF OUTPUT key to turn off the outputs.
9. Repeats steps 5 through 8 for the DETECTOR 2 bias source (make connections to the testhead DETECTOR 2 jack as shown in Figure 1-7, and use the DETECTOR 2 V_B key to set the output voltage).

Figure 1-7
Connections for DETECTOR 2 voltage bias source verification tests

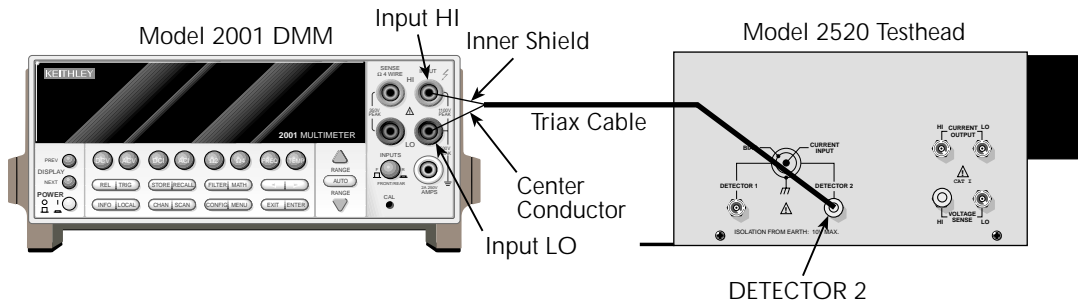

2 Calibration

Introduction

Use the procedures in this section to calibrate the Model 2520 Pulsed Laser Diode Test System. These procedures require accurate test equipment to supply and measure precise DC currents and voltages. Calibration can be performed either from the front panel or by sending SCPI calibration commands over the IEEE-488 bus or RS-232 port with the aid of a computer.

WARNING While the Model 2520 does not incorporate a laser, it is designed to operate (power) laser diode devices. Read all safety precautions listed at the beginning of the Model 2520 User's Manual. The following safety practices must be used to protect operators and other users of this product from potential exposure to laser radiation:

- Operators must be protected from radiation and electrical hazards at all times.
- The installer must comply with all applicable laws and regulations on laser safety. This requirement includes warning signs and operator training.
- The interlock is required for safe operation. The test fixtures must ensure that the interlock circuit is disabled (source outputs inhibited) so that an operator is not exposed to any radiation. The test fixture interlock must not be defeated.
- The testhead key control must be used to prevent operation unless authorized by the responsible body. This requirement must be part of the facilities administrative controls for laser safety. Outputs cannot be turned on with the key removed.
- When servicing the test system, any required personnel protection equipment (e.g. laser safety goggles) must be provided by the customer's responsible body.
- The customer's laser safety officer (LSO) must review and approve all installations before they are put into operation. Any safety concerns must be immediately reported to the customer's LSO.
- If at any time, the indicators provided on the testhead for INTERLOCK STATUS or LASER POWER ON should fail to light or properly indicate status, immediately contact a Keithley service representative for repair. Failure to do so may expose the user to hazards without proper warnings. See "Interlock status indicator test sequence" in Section 9 of the User's manual for details on testing the indicator lights.
- Maximum isolation from earth ground is 10V. Exceeding this value may result in a shock hazard.
- When making connections, do not leave any exposed connections. Ensure that all external circuits are properly insulated.

Environmental conditions

Temperature and relative humidity

Conduct the calibration procedures at an ambient temperature of 18-28°C (65-82°F) with relative humidity of less than 70% unless otherwise noted.

Warm-up period

Allow the Model 2520 to warm up for a minimum of one hour before performing calibration.

If the instrument has been subjected to temperature extremes (those outside the ranges stated above), allow additional time for the instrument's internal temperature to stabilize. Typically, allow one extra hour to stabilize a unit that is 10°C (18°F) outside the specified temperature range.

Also, allow the test equipment to warm up for the minimum time specified by the manufacturer.

Line power

The Model 2520 requires a line voltage of 100V to 240V at line frequency of 50 or 60Hz. The instrument must be calibrated while operating from a line voltage within this range.

Calibration considerations

When performing the calibration procedures:

- Make sure that the test equipment is properly warmed up and connected to the Model 2520 input or output terminals as required.
- Allow signals to settle before calibrating each point.
- Do not connect test equipment to the Model 2520 through a scanner or other switching equipment.
- If an error occurs during calibration, the Model 2520 will generate an appropriate error message. See Appendix B for more information.

WARNING The maximum common-mode voltage (voltage between LO and chassis ground) is ± 10 V DC. Exceeding this value may cause a shock hazard.

Calibration cycle

Perform calibration at least once a year to ensure the unit meets or exceeds its specifications.

Recommended calibration equipment

Table 2-1 lists the recommended equipment for the calibration procedures. You can use alternate equipment as long that equipment has specifications at least as good as those listed in the table. For optimum calibration accuracy, test equipment specifications should be at least four times better than corresponding Model 2520 specifications.

Table 2-1
Recommended calibration equipment

Description	Manufacturer/Model	Specifications
Calibrator	Fluke 5700A ¹	DC Voltage: 5V: ±5ppm 10V: ±5ppm
Digital Multimeter	Keithley 2001 ²	DC Voltage: 20V: ±22ppm DC Current: 2mA ±320ppm 20mA ±320ppm 200mA ±320ppm Resistance: 20Ω ±59ppm 200Ω ±43ppm 2kΩ ±37ppm
Resistors ³		1.2 to 1.6Ω, 2W, ±5% ⁴ 10 to 15Ω, 2W, ±5% ⁴ 10Ω, 0.5W, ±1% 100Ω, 0.5W, ±1% 200Ω, 2W, ±1% 400Ω, 1W, ±1% 1kΩ, 0.5W, ±1% 2kΩ, 0.25W, ±1% Temperature coefficient = 20ppm/°C for all resistors.

1. 90-day accuracy specifications of lowest usable range for specified output.

2. 90-day full-range accuracy specifications.

3. Characterize resistors to within ±100ppm using 4-wire ohms function of digital multimeter before use.

4. Use only non-inductive metal film or bulk metal resistors.

Resistor characterization

The precision resistors listed in Table 2-1 should be characterized to within ±100ppm using the 4-wire ohms function of the digital multimeter before use. Use the characterized values when performing the calibration procedure.

Calibration menus

Table 2-2 summarizes the main calibration menu selections. To enter the calibration menu, press the MENU key, select CAL, then press ENTER. Use the EDIT keys to move the cursor and scroll through menu selections. Press ENTER to select a MENU item.

Table 2-2

Calibration menu

Menu selection	Description
UNLOCK	Unlock calibration using password (default: 002520).
EXECUTE	Execute calibration steps for present range.
VIEW-DATES	View calibration dates.
SAVE	Save calibration constants.
LOCK	Lock out calibration.
CHANGE-PASSWORD	Change calibration password.

Table 2-3 summarizes the calibration execute menu. Each of these functions is covered in detail below.

Table 2-3

Calibration execution menu

Menu selection	Function calibrated
VL	Laser voltage measure
IL	Laser current source
COMPLIANCE	Laser source compliance
PULS_LOW	Laser source pulse low
Ipd1	Detector 1 current measure
Vb1	Detector 1 voltage bias source
Ipd2	Detector 2 current measure
Vb2	Detector 2 voltage bias source

Unlocking calibration

Before performing calibration, you must first unlock calibration by entering or sending the calibration password as explained in the following paragraphs.

Unlocking calibration from the front panel

1. Press the MENU key, then choose CAL, and press ENTER. The instrument will display the following:
CALIBRATION
UNLOCK EXECUTE VIEW-DATES ►
◀ SAVE LOCK CHANGE-PASSWORD
2. Select UNLOCK, then press ENTER. The instrument will display the following:
PASSWORD:
Use ◀, ▶, ▲, ▼, ENTER or EXIT.
3. Use the EDIT ▲ and ▼ keys to select the letter or number, and use the EDIT ◀ and ▶ arrow keys to choose the position. (Press ▲ for letters; ▼ for numbers.) Enter the present password on the display. (Front panel default: 002520.)
4. Once the correct password is displayed, press the ENTER key. You can then proceed with the calibration procedure.

Unlocking calibration by remote

To unlock calibration via remote, send the following command:

```
:CAL:PROT:CODE '<password>'
```

For example, the following command uses the default password:

```
:CAL:PROT:CODE 'KI002520'
```

Changing the password

The default password (002520) may be changed from the front panel or via remote, as discussed below.

Changing the password from the front panel

Follow the steps below to change the password from the front panel:

1. Press the MENU key, choose CAL, and press ENTER. The instrument will display the following:
CALIBRATION
UNLOCK EXECUTE VIEW-DATES ►
◀ SAVE LOCK CHANGE-PASSWORD
2. Select UNLOCK, then enter the password. (Default: 002520.)
3. Select CHANGE-PASSWORD, and then press ENTER. The instrument will display the following:
New Pwd: 002520
Use ◀, ▶, ▲, ▼, ENTER or EXIT.
4. Using the EDIT keys, enter the new password on the display.
5. Once the desired password is displayed, press the ENTER key to store the new password.

Changing the password by remote

To change the calibration password by remote, first send the present password, and then send the new password. For example, the following command sequence changes the password from the 'KI002520' remote default to 'KICAL':

```
:CAL:PROT:CODE 'KI002520'  
:CAL:PROT:CODE 'KICAL'
```

You can use any combination of letters and numbers up to a maximum of eight characters.

NOTE *If you change the first two characters of the password to something other than "KI", you will not be able to unlock calibration from the front panel.*

Resetting the calibration password

If you lose the calibration password, you can unlock calibration by shorting together the CAL pads, which are located on the display board. Doing so will also reset the password to the factory default (002520, front panel; KI002520, remote).

See Section 5 for details on disassembling the unit to access the CAL pads. Refer to the display board component layout drawing at the end of Section 6 for the location of the CAL pads.

Viewing calibration dates and calibration count

When calibration is locked, only the UNLOCK and VIEW-DATES selections will be accessible in the calibration menu. To view calibration dates and calibration count at any time:

1. From normal display, press MENU, select CAL, and then press ENTER. The unit will display the following:
CALIBRATION
UNLOCK EXECUTE VIEW-DATES ►
2. Select VIEW-DATES, and then press ENTER. The Model 2520 will display the next and last calibration dates and the calibration count as in the following example:
NEXT CAL: 07/15/2002
Last cal: 07/15/2001 Count: 0001

Calibration errors

The Model 2520 checks for errors after each calibration step, minimizing the possibility that improper calibration may occur due to operator error.

Front panel error reporting

If an error is detected during calibration, the instrument will display an appropriate error message (see Appendix B). The unit will then prompt you to repeat the calibration step that caused the error.

Remote error reporting

You can detect errors while in remote by testing the state of EAV (Error Available) bit (bit 2) in the status byte. (Use the *STB? query to request the status byte.) Query the instrument for the type of error by using the :SYST:ERR? query. The Model 2520 will respond with the error number and a text message describing the nature of the error. See Appendix B for details.

Aborting calibration steps

To abort a calibration step from the front panel, press the EXIT key. To abort a calibration step via remote, send the :ABORT command.

Testhead connections

The Model 2520 mainframe must be connected to the testhead in order to perform calibration. Using [Figure 2-1](#) as a guide, make testhead connections as follows:

CAUTION Make sure power is turned off before making connections.

- Connect mainframe TESTHEAD CONN 1 to testhead MAINFRAME CONN 1.
- Connect mainframe TESTHEAD CONN 2 to testhead MAINFRAME CONN 2.
- Short pins 1 and 9 of the REMOTE INTERLOCK connector. Insert the key in the KEY INTERLOCK and rotate to the ENABLED position to enable operation.

WARNING Shorting interlock connectors will disable the interlock. Use caution to avoid live contacts when performing calibration.

NOTE Both interlocks must be enabled to perform calibration.

Figure 2-1
Testhead connections

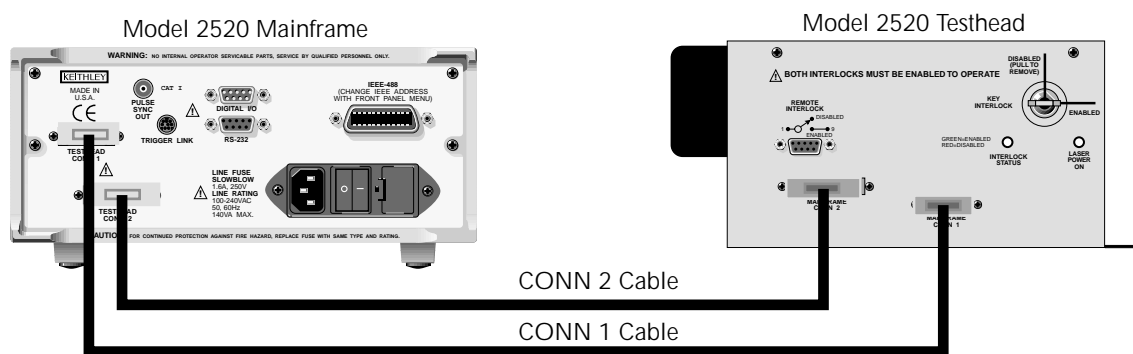

Front panel calibration

The front panel calibration procedure described below calibrates all functions. Note that each function and range is separately calibrated, and the procedure must be performed in the order shown.

Step 1: Prepare the Model 2520 for calibration

1. Turn on the Model 2520 and the calibration equipment, and allow them to warm up for a minimum of one hour before performing calibration.
2. Press the MENU key, choose CAL, and press ENTER. Select UNLOCK, and then press ENTER. The instrument will display the following:
PASSWORD:
Use ◀, ▶, ▲, ▼, ENTER or EXIT.
3. Use the EDIT ▲ and ▼ keys to select the letter or number, and use the ◀ and ▶ arrow keys to choose the position. (Press EDIT ▲ for letters; ▼ for numbers.) Enter the present password on the display. (Front panel default: 002520.)
4. Press ENTER to complete the process.
5. Press EXIT to return to normal display.

Step 2: Voltage measurement calibration

Follow the steps below to calibrate both voltage measurement ranges. [Table 2-4](#) summarizes calibration ranges and voltages.

1. From normal display, press the Model 2520 LASER V_L key, then select the 10V range using the RANGE ▲ key.
2. Press the MENU key, select CAL, then press ENTER.
3. Select EXECUTE, then press ENTER to enter the CAL EXECUTION menu.
4. Select VL, then press ENTER. The unit displays the following:
VL-CAL
Remove all inputs
5. Make sure all signal cables are disconnected from the testhead, then press ENTER. The instrument will display:
VL-CAL
Connect Calibrator HI to V-sense ▶
◀ LO and set it to -10.000V

Table 2-4

Voltage measurement calibration values

Voltage range	Calibration voltage
5V	-5.0000V
10V	-10.0000V

6. Connect the calibrator to the Model 2520 testhead VOLTAGE SENSE jacks, as shown in [Figure 2-2](#). (Connect calibrator HI to VOLTAGE SENSE LO; connect calibrator LO to VOLTAGE SENSE HI.)
7. Turn on the calibrator output, set the calibrator voltage to -10.000V, then press ENTER. The unit will prompt you as follows:
VL-CAL
Switch HI and LO connections
8. Switch the HI and LO calibrator connections, then press ENTER.
9. Press EXIT to return to normal display.
10. Press the LASER V_L key to make sure the laser volts mode is selected.
11. Press the RANGE \blacktriangledown key to select the 5V range.
12. Repeat steps 2 through 9 for the 5V range. Be sure to set the calibrator output to -5.000V as shown in [Table 2-4](#).

Figure 2-2
Voltage measurement calibration connections

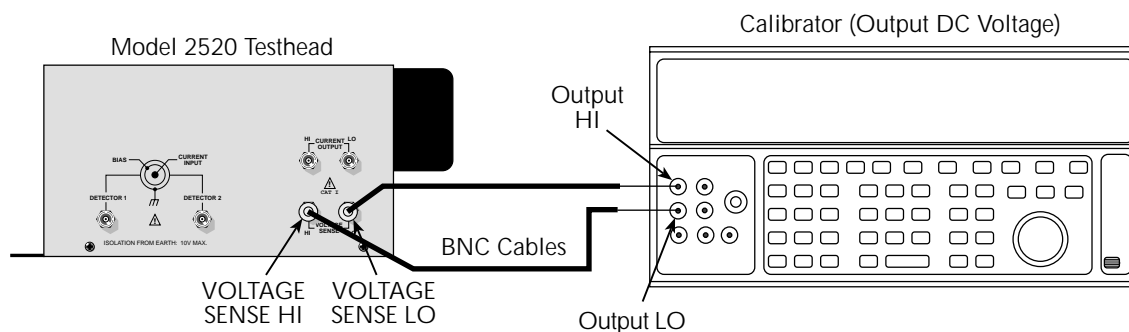

Step 3: Current source calibration

Follow the steps below to calibrate the current source. [Table 2-5](#) summarizes calibration resistors.

1. From normal display, press the Model 2520 LASER V_L key, then set the range to 10V range using the RANGE \blacktriangle key.
2. Press the LASER I_L key, press the EDIT key, then set the source to the 500mA range using the RANGE \blacktriangledown key.
3. Press the MENU key, select CAL, then press ENTER.
4. Select EXECUTE, then press ENTER to enter the calibration menu.

5. Select IL, then press ENTER. The instrument will prompt for the resistor:
RES VALUE: +15.000
Use ◀, ▶, ▲, ▼, ENTER or EXIT.

Table 2-5
Current source calibration values

Current source range	Calibration resistor
500mA	10 to 15Ω
5A	1.2 to 1.6Ω

6. Enter the measured value of the 10 to 15Ω resistor, then press ENTER. The unit displays the following:
IL-CAL
Connect Calibration Resistor to ▶
◀ Pulse Sense and Pulse Source
7. Connect the 10 to 15Ω resistor to the Model 2520 testhead VOLTAGE SENSE and CURRENT OUTPUT jacks, as shown in Figure 2-3.
8. Press ENTER to complete calibration of the present range.
9. Press EXIT to return to normal display.
10. Press LASER I_L, then EDIT, then use the RANGE ▲ key to select the 5A current range.
11. Press LASER V_L, then use the RANGE ▲ key to make sure the 10V range is selected.
12. Disconnect the 10 to 15Ω resistor, then connect the 1.2 to 1.6Ω resistor in its place (Figure 2-3).
13. Repeat steps 3 to 9 for the 5A range using the 1.2 to 1.6Ω resistor instead of the 10 to 15Ω resistor.

Figure 2-3
Current source calibration connections

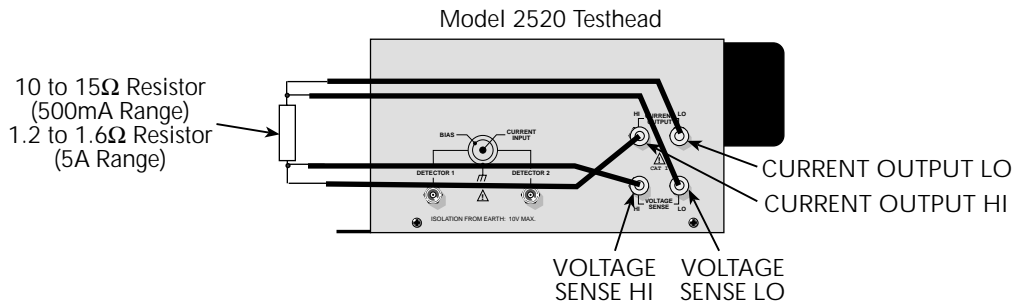

Step 4: Pulse low calibration

Follow the steps below to calibrate current source pulse low. [Table 2-6](#) summarizes calibration currents and test resistance values.

1. Connect DMM and 100Ω resistor to the Model 2520 testhead CURRENT OUTPUT jacks, as shown in [Figure 2-4](#).
2. Select the DMM DC volts function, and enable auto-range.
3. Press the LASER I_L key, press the EDIT key, then set the source to the 500mA range using the RANGE ▼ key.
4. Press the MENU key, select CAL, then press ENTER.
5. Select EXECUTE, then press ENTER to enter the calibration menu.
6. Select PULS_LOW, then press ENTER. The unit displays:
Pulse Low CAL
Press ENTER to Output +15.000mA
7. Press ENTER. The unit displays:
DMM RDG: +15.000mA
Use ◀, ▶, ▲, ▼, ENTER or EXIT.
8. Note the DMM voltage reading, then calculate the current from the voltage and actual resistance value: $I = V/R$.
9. Adjust the display to agree with the calculated current, then press ENTER. The unit displays:
Pulse Low CAL
Press ENTER to Output +01.500mA
10. Press ENTER. The unit displays:
DMM RDG: +01.500mA
Use ◀, ▶, ▲, ▼, ENTER or EXIT.
11. Again, note the DMM voltage reading, then calculate the current from the voltage and actual resistance value: $I = V/R$.

Table 2-6

Pulse low calibration values

Current source range	Calibration values	Calibration resistance
500mA	15mA, 1.5mA	100Ω
5A	150mA, 15mA	10Ω

12. Adjust the display to agree with the calculated, then press ENTER. The unit displays the following:
Pulse Low CAL
Press ENTER to Output +15.000mA
13. Press ENTER. The unit displays:
DMM RDG: +15.000mA
Use ◀▶, ▲, ▼, ENTER or EXIT.
14. Note the DMM voltage reading, then calculate the current from the voltage and actual resistance value: $I = V/R$.
15. Adjust the display to agree with the calculated, then press ENTER. The unit displays:
Pulse Low CAL
Press ENTER to Output +01.500mA
16. Press ENTER. The unit displays:
DMM RDG: +01.500mA
Use ◀▶, ▲, ▼, ENTER or EXIT.
17. Note the DMM voltage reading, then calculate the current from the voltage and actual resistance value: $I = V/R$.
18. Adjust the display to agree with the calculated, then press ENTER.
19. Press EXIT to return to normal display.
20. Disconnect the 100Ω resistor, and connect the 10Ω resistor in its place (Figure 2-4).
21. Press LASER I_L, then EDIT, then use the RANGE ▲ key to select the 5A current range.
22. Repeat steps 5 through 19 for the 5A range.

Figure 2-4
Pulse low calibration connections

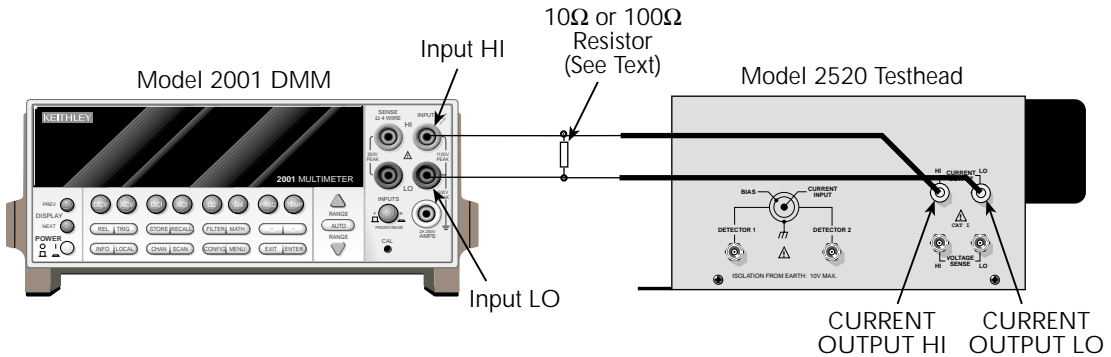

Step 5: Voltage bias source calibration

Follow the steps below to calibrate both bias voltage sources.

1. Connect the DMM to the Model 2520 testhead DETECTOR 1 and VOLTAGE SENSE HI jacks, as shown in [Figure 2-5](#). (Be sure to connect DMM LO to the inner shield of the DETECTOR triax cable.)
2. Select the DMM DC volts function, and enable auto-range.
3. Press the MENU key, select CAL, then press ENTER.
4. Select EXECUTE, then press ENTER to enter the CAL EXECUTION menu.
5. Select Vb1, then press ENTER.
6. The instrument will prompt for -20V calibration:
Vbias 1 CAL
Press ENTER to Output -20.000 V
7. Press ENTER. The instrument will display the following message:
DMM RDG: -20.00000 V
Use ◀, ▶, ▲, ▼, ENTER or EXIT.
8. Note the DMM voltage reading, then use the EDIT keys to adjust the Model 2520 display value to agree with that reading.

Figure 2-5
Detector 1 voltage bias source calibration connections

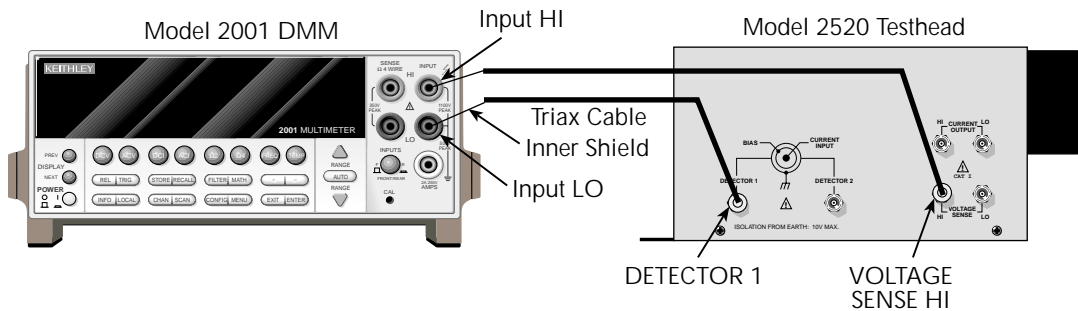

9. Press ENTER. The unit will prompt for the 0V calibration point:
Vbias 1 CAL
Press ENTER to Output +00.000 V
10. Press ENTER. The instrument will display the following message:
DMM RDG: +00.00000 V
Use ◀▶, ▲, ▼, ENTER or EXIT.
11. Note the DMM voltage reading, then use the EDIT keys to adjust the Model 2520 display value to agree with the reading.
12. Press ENTER. The unit will display the prompt for the +20V calibration point:
Vbias 1 CAL
Press ENTER to Output +20.000 V
13. Press ENTER. The instrument will display the following message:
DMM RDG: +20.00000 V
Use ◀▶, ▲, ▼, ENTER or EXIT.
14. Note the DMM voltage reading, then use the EDIT keys to adjust the Model 2520 display value to agree with the reading, and press ENTER.
15. Press EXIT to return to normal display.
16. Repeat steps 4 through 15 for the DETECTOR 2 bias voltage source. Make your connections to the testhead DETECTOR 2 jack (Figure 2-6), and select Vb2 for calibration.

Figure 2-6
Detector 2 voltage bias source calibration connections

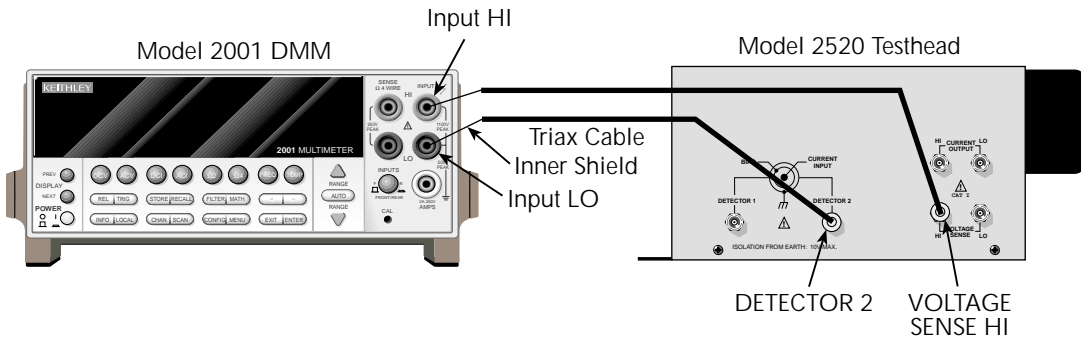

Step 6: Current measurement calibration

Follow the steps below to calibrate all photodiode current measurement ranges. [Table 2-7](#) summarizes calibration ranges and resistors.

Table 2-7
Current measurement calibration values

Current range	Calibration resistor*
10mA	2k Ω
20mA	1k Ω
50mA	400 Ω
100mA	200 Ω

* Nominal values. Use measured values for procedure.

1. Select the DMM DC volts function, and enable auto-range. Temporarily short the ends of the DMM test leads together, then enable REL to null offsets.
2. Connect the 2k Ω resistor and the DMM to the Model 2520 testhead DETECTOR 1 jack, as shown in [Figure 2-7](#).
3. From normal display, press the Model 2520 DETECTOR 1 I_{PD} key, then select the 10mA current range using the RANGE \blacktriangledown key.
4. Press the MENU key, select CAL, then press ENTER.
5. Select EXECUTE, then press ENTER to enter the CAL EXECUTION menu.
6. Select Ipd1, then press ENTER. The instrument will prompt for the resistor value:
RES VALUE: +2000.00
Use \blacktriangleleft , \blacktriangleright , \blacktriangle , \blacktriangledown , ENTER or EXIT.

Figure 2-7
Detector 1 current measurement calibration connections

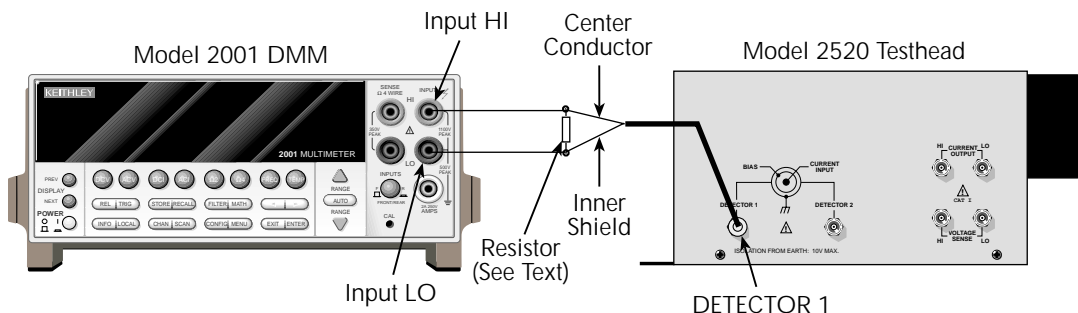

7. Press ENTER. The instrument will prompt for calibration with -20V:
Ipd 1 CAL
Press ENTER to Output -20.000 V
8. Press ENTER. The unit will display:
DMM RDG: -20.000 V
Use ◀▶, ▲, ▼, ENTER or EXIT.
9. Use the EDIT keys to adjust the Model 2520 display value to agree with the DMM voltage reading.
10. Press ENTER. The instrument will prompt for 0V calibration:
Ipd 1 CAL
Press ENTER to Output +00.000 V
11. Press ENTER. The unit will display:
DMM RDG: +00.000 V
Use ◀▶, ▲, ▼, ENTER or EXIT.
12. Use the EDIT keys to adjust the Model 2520 display value to agree with the DMM reading.
13. Press ENTER. The instrument will prompt for calibration with +20V:
Ipd 1 CAL
Press ENTER to Output +20.000 V
14. Press ENTER. The unit will display:
DMM RDG: +20.000 V
Use ◀▶, ▲, ▼, ENTER or EXIT.
15. Use the EDIT keys to adjust the Model 2520 display value to agree with the DMM reading, then press ENTER.
16. Press EXIT to return to normal display.
17. Repeat steps 3 through 16 for the 20mA, 50mA, and 100mA ranges, using [Table 2-7](#) as a guide. Be sure to set the Model 2520 to the correct range using the RANGE ▲ and ▼ keys, and use the correct resistor for each range.
18. Repeat steps 3 through 17 for the DETECTOR 2 measurement channel. Make calibrator connections to the testhead DETECTOR 2 jack (see [Figure 2-8](#)).

Figure 2-8
Detector 2 current measurement calibration connections

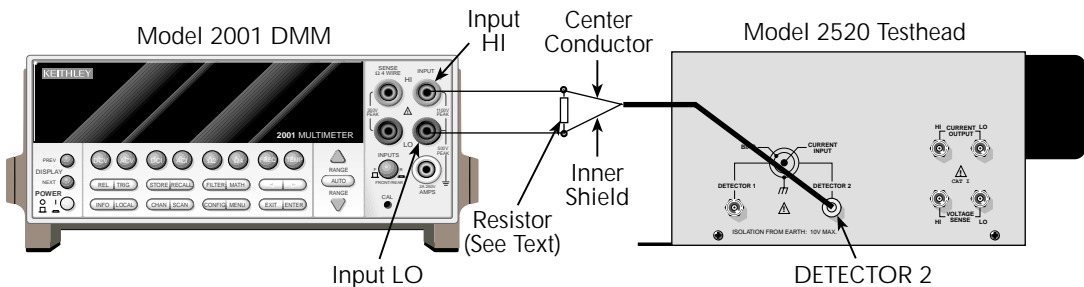

Step 7: Compliance calibration

Follow the steps below to calibrate compliance:

1. Connect the DMM to the CURRENT OUTPUT jacks, as shown in [Figure 2-9](#). Select the DC volts function, and enable auto-range.
2. From normal display, press LASER I_L, then press the EDIT key.
3. Press the EDIT ►: key.
4. Select the 500mA key with the RANGE ▼ key.
5. Using the EDIT ◀ and ►: keys and EDIT ▲ and ▼ keys, set the current source to 100.00mA.
6. Press the MENU key, select CAL, then press ENTER.
7. Select EXECUTE, then press ENTER to enter the CAL EXECUTION menu.
8. Select COMPLIANCE, then press ENTER. The unit displays the following:
Compliance CAL
Press ENTER to Output +10.500V
9. Press ENTER. The instrument will display:
DMM RDG: +10.500 V
Use ◀, ►, ▲, ▼, ENTER or EXIT.
10. Note the DMM reading, then adjust the Model 2520 display to agree with that value.
11. Press ENTER. The instrument will display:
DMM RDG: +03.000 V
Use ◀, ►, ▲, ▼, ENTER or EXIT.
12. Note the DMM reading, then adjust the Model 2520 display to agree with that value. Press ENTER to complete compliance calibration.

Figure 2-9
Compliance calibration connections

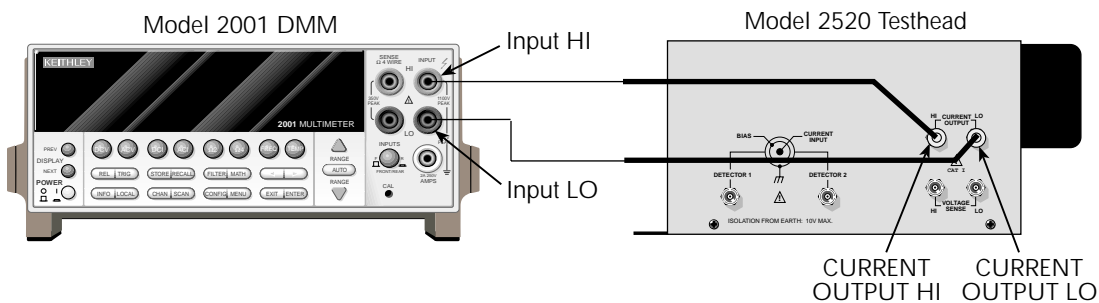

Step 8: Enter calibration dates and save calibration

NOTE For temporary calibration without saving new calibration constants, proceed to Step 9: Lock out calibration.

1. From the CALIBRATION menu, select SAVE, and then press ENTER. The unit will prompt you for the calibration date:
CAL DATE: 08/15/2001
Use ◀ ▶ ▲ ▼, ENTER or EXIT.
2. Using the EDIT keys, change the displayed date to today's date, and then press the ENTER key. Press ENTER again to confirm the date.
3. The unit will then prompt for the calibration due date:
NEXT CAL: 08/15/2002
Use ◀ ▶ ▲ ▼, ENTER or EXIT.
4. Set the calibration due date to the desired value, and then press ENTER. Press ENTER again to confirm the date.
5. Once the calibration dates are entered, calibration is complete, and the following message will be displayed:
CALIBRATION COMPLETE
Press ENTER to save; EXIT to abort
6. Press ENTER to save the calibration data (or press EXIT to abort without saving calibration data.)

Step 9: Lock out calibration

From the CAL EXECUTION menu, select LOCK, and then press ENTER to lock out calibration. Press EXIT to return to normal display.

Remote calibration

Use the following procedure to perform remote calibration by sending SCPI commands over the IEEE-488 bus or RS-232 port. The remote commands and appropriate parameters are separately summarized for each step.

Remote calibration command summary

Table 2-8 summarizes only those remote calibration commands used in this section.

NOTE For a detailed description of all calibration commands and queries, refer to Appendix B.

Table 2-8

Remote calibration command summary

Command	Description
:CALibration	Calibration subsystem.
:PROtected	Calibration commands protected by password.
:CODE '<password>'	Unlock calibration. (Default password: KI002520.)
:CODE?	Query password (if calibration is unlocked).
:SENSe[1] <NRf>	Calibrate active range of voltage measurement.
:SENSe2 <NRf>	Calibrate active range of detector 1 current measurement.
:SENSe3 <NRf>	Calibrate active range of detector 2 current measurement.
:SOURce[1] <NRf>	Calibrate active range of current source.
:PROtECTION <NRf>	Calibrate voltage compliance.
:LOW <NRf>	Calibrate current source pulse low output level.
:SOURce2 <NRf>	Calibrate detector 1 voltage bias source.
:SOURce3 <NRf>	Calibrate detector 2 voltage bias source.
:DATE <yyyy>,<mm>,<dd>	Program calibration year, month, day.
:NDUE <yyyy>,<mm>,<dd>	Program calibration due year, month, day.
:SAVE	Save calibration constants in EEPROM.
:LOCK	Lock out calibration.
:DIAGnostic	Diagnostic subsystem.
:KEIThley	
:FCON	
:HI 	Internally connect VOLTAGE SENSE HI input to floating ground.
:LO 	Internally connect VOLTAGE SENSE LO input to floating ground.

Remote calibration procedure

Step 1: Prepare the Model 2520 for calibration

1. With the power off, connect the Model 2520 to the controller IEEE-488 interface or RS-232 port using a shielded interface cable.
2. Turn on the Model 2520 and the test equipment, and allow them to warm up for a minimum of one hour before performing calibration.
3. If you are using the IEEE-488 interface, make sure the primary address of the Model 2520 is the same as the address specified in the program you will be using to send commands. (Use the COMM key to access the IEEE-488 address.)
4. Send the following command to unlock calibration:
:CAL:PROT:CODE 'KI002520'

Step 2: Voltage measurement calibration

Follow these steps to calibrate voltage measurements. [Table 2-9](#) summarizes calibration voltages and commands.

1. Put the unit into the DC mode with this command:
:SOUR1:FUNC:SHAP DC
2. Send the following command to select the 10V range:
:SENS1:VOLT:RANG 10
3. Disconnect all signal cables from the testhead.
4. Send the following commands in order:
:DIAG:KEIT:FCON:HI ON
:DIAG:KEIT:FCON:LO ON
:SENS1:VOLT:POL NEG
:CAL:PROT:SENS1 0
:SENS1:VOLT:POL POS
:CAL:PROT:SENS1 0
:DIAG:KEIT:FCON:LO OFF
5. Connect the calibrator to the Model 2520 testhead VOLTAGE SENSE jacks, as shown in [Figure 2-2](#).
6. Set the calibrator voltage output to -10.000V, and turn on its output.
7. Send the following command to calibrate the +10V point:
:CAL:PROT:SENS1 10
8. Reverse the calibrator HI and LO connections.
9. Send the following commands to calibrate the negative full-range voltage point:
:DIAG:KEIT:FCON:HI OFF
:DIAG:KEIT:FCON:LO ON
:SENS1:VOLT:POL NEG
:CAL:PROT:SENS1 -10
:DIAG:KEIT:FCON:LO OFF
10. Repeat steps 2 through 9 for the 5V range using [Table 2-9](#) as a guide. Be sure to:
 - Select the 5V range using the :SENS1:VOLT:RANG 5 command.
 - Send the appropriate calibration voltage values with the :CAL:PROT:SENS1 <Voltage> command.

*Table 2-9
Voltage measurement calibration voltages and commands*

Voltage range	Calibration voltages*	Calibration commands
5V	0 -5.00000V +5.00000V	:SOURI:FUNC:SHAP DC :SENS1:VOLT:RANG 5 :DIAG:KEIT:FCON:HI ON :DIAG:KEIT:FCON:LO ON :SENS1:VOLT:POL NEG :CAL:PROT:SENS1 0 :SENS1:VOLT:POL POS :CAL:PROT:SENS1 0 :DIAG:KEIT:FCON:LO OFF :CAL:PROT:SENS1 5 :DIAG:KEIT:FCON:HI OFF :DIAG:KEIT:FCON:LO ON :SENS1:VOLT:POL NEG :CAL:PROT:SENS1 -5 :DIAG:KEIT:FCON:LO OFF
10V	0 -10.0000V +10.0000V	:SOURI:FUNC:SHAP DC :SENS1:VOLT:RANG 10 :DIAG:KEIT:FCON:HI ON :DIAG:KEIT:FCON:LO ON :SENS1:VOLT:POL NEG :CAL:PROT:SENS1 0 :SENS1:VOLT:POL POS :CAL:PROT:SENS1 0 :DIAG:KEIT:FCON:LO OFF :CAL:PROT:SENS1 10 :DIAG:KEIT:FCON:HI OFF :DIAG:KEIT:FCON:LO ON :SENS1:VOLT:POL NEG :CAL:PROT:SENS1 -10 :DIAG:KEIT:FCON:LO OFF

* Polarity reversed by switching calibrator connections. See procedure.

Step 3: Current source calibration

Follow these steps to calibrate the current source. [Table 2-10](#) summarizes current source calibration resistances and commands.

1. Send the following command to select the pulse mode:
:SOUR1:FUNC:SHAP PULS
2. Send the following commands to set source and measure polarities:
:SENS1:VOLT:POL POS
:SOUR1:CURR:POL POS
3. Connect the 10 to 15 Ω resistor to the Model 2520 testhead VOLTAGE SENSE and CURRENT OUTPUT jacks, as shown in [Figure 2-3](#).
4. Set the pulse transition to fast:
:SOUR1:PULS:TRAN:STAT OFF
5. Set ranges with these commands:
:SENS1:VOLT:RANG 10
:SOUR1:CURR:RANG 0.5
6. Send this command to turn on the source output:
:OUTP1 ON
7. Set the compliance DAC to full scale so that it does not affect the measurement:
:DIAG:KEIT:BITS:VDAC1 4095
8. Source 10% of full scale:
:SOUR1:CURR 0.05
9. Trigger a pulse:
:INIT
10. Send the following query to request the Model 2520 voltage measurement:
:SENS1:DATA?
11. Note the voltage reading returned by the Model 2520 in step 10, then calculate the actual sourced current as follows: $I = V/R$. Here, I is the actual sourced current, V is the returned Model 2520 voltage reading, and R is the actual resistance value.
12. Send the following calibration command using the current calculated in step 11:
:CAL:PROT:SOUR1 <Calculated_Current>
For example, if the resistance value is 14.02 Ω , and the returned voltage reading from step 10 is 0.6732V, the actual current is: $I = 0.6732\text{V}/14.02\Omega = 0.048017\text{A}$.
In this example, the calibration command is:
:CAL:PROT:SOUR1 0.048017
13. Send this command to source 90% of full scale current:
:SOUR1:CURR 0.45
14. Repeat steps 9 through 12.
15. Send this command to select the slow transition pulse:
:SOUR1:PULS:TRAN:STAT ON

Table 2-10
Remote current source calibration summary

Current range	Calibration resistance ¹	Calibration commands
N/A		:SOUR1:FUNC:SHAP PULS :SENS1:VOLT:POL POS :SOUR1:CURR:POL POS
500mA	10 to 15Ω	:SOUR1:PULS:TRAN:STAT ON OFF ² :SENS1:VOLT:RANG 10 :SOUR1:CURR:RANG 0.5 :OUTP1 ON :DIAG:KEIT:BITS:VDAC1 4095 :SOUR1:CURR 0.05 :INIT :SENS1:DATA? :CAL:PROT:SOUR1 <Calculated_Current> ³ :SOUR1:CURR 0.45 :INIT :SENS1:DATA? :CAL:PROT:SOUR1 <Calculated_Current> ³ :OUTP1 OFF
5A	1.2 to 1.6Ω	:SOUR1:PULS:TRAN:STAT ON OFF ² :SENS1:VOLT:RANG 10 :SOUR1:CURR:RANG 5 :OUTP1 ON :DIAG:KEIT:BITS:VDAC1 4095 :SOUR1:CURR 0.5 :INIT :SENS1:DATA? :CAL:PROT:SOUR1 <Calculated_Current> ³ :SOUR1:CURR 4.5 :INIT :SENS1:DATA? :CAL:PROT:SOUR1 <Calculated_Current> ³ :OUTP1 OFF

1. Use characterized resistance values.
2. Repeat steps for both fast and slow pulse transition. See procedure.
3. Calculate current from voltage measurement and actual resistance: $I = V/R$.

16. Repeat steps 5 through 14 to calibrate the slow transition pulse.
17. Repeat steps 3 through 16 for the 5A range with the following exceptions:
 - Use the 1.2 to 1.6 Ω resistor.
 - Select the 5A source range with this command:
:SOUR1:CURR:RANG 5
 - Set the appropriate 10% (0.5) and 90% (4.5) of range values using this command:
:SOUR1:CURR <Current>
18. Send this command to turn off the output:
:OUTP1 OFF

Step 4: Pulse low calibration

Follow these steps to calibrate current source pulse low. [Table 2-11](#) summarizes calibration resistances and commands.

1. Connect the 100 Ω resistor and DMM to the Model 2520 testhead CURRENT OUTPUT jacks, as shown in [Figure 2-4](#).
2. Select the DMM DC volts function, and enable auto-range.
3. Put the unit into the pulse mode:
:SOUR1:FUNC:SHAP PULS
4. Send this command to turn on the source output:
:OUTP1 ON
5. Enable fast transition pulses:
:SOUR1:PULS:TRAN:STAT OFF
6. Send the following command to select the 500mA current range:
:SOUR1:CURR:RANG 0.5
7. Send this command to set the current to 15mA:
:SOUR1:CURR:LOW 15e-3
8. Note the DMM reading, then calculate the current from the voltage and actual resistance, adding a slight offset value: $I = V/R + 90\mu\text{A}$.
9. Send the calculated current value as the parameter for the following command:
:CAL:PROT:SOUR1:LOW <Calculated_current>
For example, if the current is 14.5mA, the correct command is:
:CAL:PROT:SOUR1:LOW 14.59e-3
10. Send this command to set the current to 1.5mA:
:SOUR1:CURR:LOW 1.5e-3
11. Note the DMM reading, then calculate the current from the voltage and actual resistance, subtracting a slight offset value: $I = V/R - 75\mu\text{A}$.
12. Send the calculated current value as the parameter for the following command:
:CAL:PROT:SOUR1:LOW <Calculated_current>

13. Enable slow pulses:
:SOUR1:PULS:TRAN:STAT ON
14. Repeat steps 5 through 12.
15. Send this command to turn off the output:
:OUTP1 OFF
16. Disconnect the 100Ω resistor, then connect the 10Ω resistor in its place.
17. Repeat steps 3 through 15 for the 5A range with the following changes:
 - Select the 5A range:
:SOUR1:CURR:RANG 5
 - Use these commands to set the two low current values:
:SOUR1:CURR:LOW 0.15
:SOUR1:CURR:LOW 0.015
 - Use 900μA and 750μA respectively as the offsets when calculating the
:CAL:PROT:SOUR1:LOW parameter.

Table 2-11

Remote pulse low calibration summary

Current range	Calibration resistance ¹	Calibration commands
N/A		:SOUR1:FUNC:SHAP PULS
500mA	100Ω	:OUTP1 ON :SOUR1:PULS:TRAN:STAT OFF ON ² :SOUR1:CURR:RANG 0.5 :SOUR1:CURR:LOW 15e-3 :CAL:PROT:SOUR1:LOW <Current + 90μA> :SOUR1:CURR:LOW 1.5e-3 :CAL:PROT:SOUR1:LOW <Current - 75μA> :OUTP1 OFF
5A	10Ω	:OUTP1 ON :SOUR1:PULS:TRAN:STAT OFF ON ² :SOUR1:CURR:RANG 5 :SOUR1:CURR:LOW 150e-3 :CAL:PROT:SOUR1:LOW <Current + 900μA> :SOUR1:CURR:LOW 15e-3 :CAL:PROT:SOUR1:LOW <Current - 750μA> :OUTP1 OFF

1. Use actual resistance values when calculating currents.

2. Repeat steps for both fast and slow pulses. See procedure.

Step 5: Voltage bias source calibration

Follow these steps to calibrate the two voltage bias sources. [Table 2-12](#) summarizes calibration voltages and commands.

1. Connect the DMM to the Model 2520 testhead DETECTOR 1 and VOLTAGE SENSE HI jacks, as shown in [Figure 2-5](#).
2. Select the DMM DC voltage function, and enable auto-range.
3. Connect the VOLTAGE SENSE HI terminal to internal ground:
:DIAG:KEIT:FCON:HI ON
4. Send this command to turn on the output:
:OUTP1 ON
5. Send the following command to output +20V:
:SOUR2:VOLT 20
6. Note and record the DMM reading, and then send the negative of that value as the parameter for the following command:
:CAL:PROT:SOUR2 -<DMM_Reading>
7. Send the following command to output 0V:
:SOUR2:VOLT 0
8. Note and record the DMM reading, and then send the negative of that value as the parameter for the following command:
:CAL:PROT:SOUR2 -<DMM_Reading>
9. Send the following command to output -20V:
:SOUR2:VOLT -20
10. Note and record the DMM reading, and then send the negative of that value as the parameter for the following command:
:CAL:PROT:SOUR2 -<DMM_Reading>
11. Send this command to turn off the outputs:
:OUTP1 OFF
12. Disconnect VOLTAGE SENSE HI from ground:
:DIAG:KEIT:FCON:HI OFF
13. Repeat steps 3 through 12 for detector 2 using [Table 2-12](#) as a guide. Be sure to:
 - Connect the DMM to the testhead DETECTOR 2 and VOLTAGE SENSE HI jacks ([Figure 2-6](#)).
 - Send source values using the :SOUR3:VOLT command where appropriate.
 - Calibrate each point using the :CAL:PROT:SOUR3 command.

Table 2-12
Remote voltage bias source calibration summary

Voltage bias channel	Calibration voltages	Calibration commands*
Detector 1	+20V 0V -20V	:DIAG:KEIT:FCON:HI ON :OUTP1 ON :SOUR2:VOLT 20 :CAL:PROT:SOUR2 -<DMM_Reading> :SOUR2:VOLT 0 :CAL:PROT:SOUR2 -<DMM_Reading> :SOUR2:VOLT -20 :CAL:PROT:SOUR2 -<DMM_Reading> :OUTP1 OFF :DIAG:KEIT:FCON:HI OFF
Detector 2	+20V 0V -20V	:DIAG:KEIT:FCON:HI ON :OUTP1 ON :SOUR3:VOLT 20 :CAL:PROT:SOUR3 -<DMM_Reading> :SOUR3:VOLT 0 :CAL:PROT:SOUR3 -<DMM_Reading> :SOUR3:VOLT -20 :CAL:PROT:SOUR3 -<DMM_Reading> :OUTP1 OFF :DIAG:KEIT:FCON:HI OFF

*Command parameter values are negative of the displayed DMM reading.

Step 6: Current measurement calibration

Follow these steps to calibrate current measurements for both photodiode detector channels. Table 2-13 summarizes calibration currents and commands.

1. Select the DMM DC voltage function, and enable auto-range.
2. Temporarily short the ends of the DMM test leads together, and enable the REL mode to null offsets.
3. Connect the DMM and 2k Ω resistor to the Model 2520 testhead DETECTOR 1 jack, as shown in Figure 2-7.
4. Send the following command to select the 10mA range:
:SENS2:CURR:RANG 10e-3
5. Put the unit into the DC mode:
:SOUR1:FUNC:SHAP DC
6. Select positive current measurement polarity:
:SENSE2:CURR:POL POS

7. Send this command to turn on the outputs:
:OUTP1 ON
8. Send the following command to output -20V:
:SOUR2:VOLT -20
9. Note the DMM voltage reading, then calculate the current from the characterized resistance value and DMM voltage reading: $I = V/R$
10. Send the following command to calibrate the negative full-range current point:
:CAL:PROT:SENS2 <Calculated_current>
11. Send the following command to output 0V:
:SOUR2:VOLT 0
12. Note the DMM voltage reading, then calculate the current from the characterized resistance value and DMM voltage reading: $I = V/R$
13. Send the following command to calibrate the zero range current point:
:CAL:PROT:SENS2 <Calculated_current>
14. Switch current measurement polarity to negative:
:SENSE2:CURR:POL NEG
15. Calibrate the negative zero range current point:
:CAL:PROT:SENS2 <Calculated_current>
16. Send the following command to output +20V:
:SOUR1:VOLT 20
17. Note the DMM voltage reading, then calculate the current from the characterized resistance value and DMM voltage reading: $I = V/R$
18. Send the following command to calibrate the positive full-range current point:
:CAL:PROT:SENS2 <Calculated_current>
Note that if the measured voltage is negative, the current will be negative.
19. Repeat steps 4 through 18 for the 20mA, 50mA, and 100mA ranges using [Table 2-13](#) as a guide. Be sure to:
 - Select the appropriate range using the :SENS2:CURR:RANG <Range> command.
 - Send the appropriate calibration current values with the :CAL:PROT:SENS2 <Current> command.
20. Turn off the outputs by sending:
:OUTP1 OFF
21. Repeat steps 3 through 20 for the other photodiode current measurement channel. Be sure to:
 - Connect the DMM and resistor to the testhead DETECTOR 2 jack ([Figure 2-8](#)).
 - Use the :SOUR3:CURR:RANG command to select the correct range.
 - Use the :CAL:PROT:SOUR3 command for each calibration point.

Table 2-13

Remote current measurement calibration currents and commands

Channel	Current range	Test resistor*	Calibration currents*	Calibration commands*
Detector 1	10mA	2k Ω	-10mA	:OUTP1 ON :SENS2:CURR:RANG 10e-3 :SOUR1:FUNC:SHAP DC :SENSE2:CURR:POL POS :SOUR2:VOLT -20 :CAL:PROT:SENS2 <Current> :SOUR2:VOLT 0
			0mA	:CAL:PROT:SENS2 <Current> :SENSE2:CURR:POL NEG
			0mA	:CAL:PROT:SENS2 <Current> :SOUR2:VOLT 20
			+10mA	:CAL:PROT:SENS2 <Current>
	20mA	1k Ω	-20mA	:SENS2:CURR:RANG 20e-3 :SOUR1:FUNC:SHAP DC :SENSE2:CURR:POL POS :SOUR2:VOLT -20 :CAL:PROT:SENS2 <Current> :SOUR2:VOLT 0
			0mA	:CAL:PROT:SENS2 <Current> :SENSE2:CURR:POL NEG
			0mA	:CAL:PROT:SENS2 <Current> :SOUR2:VOLT 20
			+20mA	:CAL:PROT:SENS2 <Current>
	50mA	400 Ω	-50mA	:SENS2:CURR:RANG 50e-3 :SOUR1:FUNC:SHAP DC :SENSE2:CURR:POL POS :SOUR2:VOLT -20 :CAL:PROT:SENS2 <Current> :SOUR2:VOLT 0
0mA			:CAL:PROT:SENS2 <Current> :SENSE2:CURR:POL NEG	
0mA			:CAL:PROT:SENS2 <Current> :SOUR2:VOLT 20	
+50mA			:CAL:PROT:SENS2 <Current>	

* Nominal values shown. Calculate actual current from characterized resistance and DMM voltage reading: $I = V/R$.

Table 2-13 (continued)

Remote current measurement calibration currents and commands

Channel	Current range	Test resistor*	Calibration currents*	Calibration commands*
Detector 1	100mA	200Ω	-100mA 0mA 0mA +100mA	:SENS2:CURR:RANG 100e-3 :SOUR1:FUNC:SHAP DC :SENSE2:CURR:POL POS :SOUR2:VOLT -20 :CAL:PROT:SENS2 <Current> :SOUR2:VOLT 0 :CAL:PROT:SENS2 <Current> :SENSE2:CURR:POL NEG :CAL:PROT:SENS2 <Current> :SOUR2:VOLT 20 :CAL:PROT:SENS2 <Current> :OUTP1 OFF
Detector 2	10mA	2kΩ	-10mA 0mA 0mA +10mA	:OUTP1 ON :SENS3:CURR:RANG 10e-3 :SOUR1:FUNC:SHAP DC :SENSE3:CURR:POL POS :SOUR3:VOLT -20 :CAL:PROT:SENS3 <Current> :SOUR3:VOLT 0 :CAL:PROT:SENS3 <Current> :SENSE3:CURR:POL NEG :CAL:PROT:SENS3 <Current> :SOUR3:VOLT 20 :CAL:PROT:SENS3 <Current>
	20mA	1kΩ	-20mA 0mA 0mA +20mA	:SENS3:CURR:RANG 20e-3 :SOUR1:FUNC:SHAP DC :SENSE3:CURR:POL POS :SOUR3:VOLT -20 :CAL:PROT:SENS3 <Current> :SOUR3:VOLT 0 :CAL:PROT:SENS3 <Current> :SENSE3:CURR:POL NEG :CAL:PROT:SENS3 <Current> :SOUR3:VOLT 20 :CAL:PROT:SENS3 <Current>

* Nominal values shown. Calculate actual current from characterized resistance and DMM voltage reading: $I = V/R$.

Table 2-13 (continued)

Remote current measurement calibration currents and commands

Channel	Current range	Test resistor*	Calibration currents*	Calibration commands*
Detector 2	50mA	400Ω	-50mA 0mA 0mA +50mA	:SENS3:CURR:RANG 50e-3 :SOUR1:FUNC:SHAP DC :SENSE3:CURR:POL POS :SOUR3:VOLT -20 :CAL:PROT:SENS3 <Current> :SOUR3:VOLT 0 :CAL:PROT:SENS3 <Current> :SENSE3:CURR:POL NEG :CAL:PROT:SENS3 <Current> :SOUR3:VOLT 20 :CAL:PROT:SENS3 <Current>
	100mA	200Ω	-100mA 0mA 0mA +100mA	:SENS3:CURR:RANG 100e-3 :SOUR1:FUNC:SHAP DC :SENSE3:CURR:POL POS :SOUR3:VOLT -20 :CAL:PROT:SENS3 <Current> :SOUR3:VOLT 0 :CAL:PROT:SENS3 <Current> :SENSE3:CURR:POL NEG :CAL:PROT:SENS3 <Current> :SOUR3:VOLT 20 :CAL:PROT:SENS3 <Current> :OUTP1 OFF

* Nominal values shown. Calculate actual current from characterized resistance and DMM voltage reading: $I = V/R$.

Step 7: Compliance calibration

Follow the steps below to calibrate compliance. [Table 2-14](#) summarizes calibration steps.

1. Connect the DMM to the Model 2520 testhead CURRENT OUTPUT jacks, as shown in [Figure 2-9](#).
2. Select the DMM DC volts function, and enable auto-range.
3. Put the unit into the DC mode:
:SOUR1:FUNC:SHAP DC
4. Send this command to turn on the source output:
:OUTP1 ON
5. Send the following command to set the current to 100mA:
:SOUR1:CURR 0.1
6. Set the voltage compliance to 10.5V:
:SOUR1:VOLT:PROT 10.5
7. Note the DMM voltage reading, then send the value as the parameter for the following command:
:CAL:PROT:SOUR1:PROT <DMM_Reading>
For example, if the voltage is 10.45V, the correct command is:
:CAL:PROT:SOUR1:PROT 10.45
8. Set the voltage compliance to 3V:
:SOUR1:VOLT:PROT 3
9. Note the DMM voltage reading, then send the value as the parameter for the following command:
:CAL:PROT:SOUR1:PROT <Voltage>
10. Send this command to turn off the output:
:OUTP1 OFF

Table 2-14

Remote compliance calibration summary

Command	Description
:SOUR1:FUNC:SHAP DC	Select DC source mode.
:OUTP1 ON	Turn output on.
:SOUR1:CURR 0.1	Source 100mA.
:SOUR1:VOLT:PROT 10.5	Set compliance to 10.5V.
:CAL:PROT:SOUR1:PROT <DMM_Reading>	Calibrate 10.5V compliance.
:SOUR1:VOLT:PROT 3	Set compliance to 3V.
:CAL:PROT:SOUR1:PROT <DMM_Reading>	Calibrate 3V compliance.
:OUTP1 OFF	Turn output off.

Step 8: Program calibration dates

Use the following commands to set the calibration date and calibration due date:

```
:CAL:PROT:DATE    <yyyy>, <mm>, <dd>    (Calibration date)
:CAL:PROT:NDUE    <yyyy>, <mm>, <dd>    (Next calibration due date)
```

Note that the year, month, and date must be separated by commas.

Step 9: Save calibration constants

Calibration is now complete. You can store the calibration constants in EEROM by sending the following command:

```
:CAL:PROT:SAVE
```

NOTE Calibration will be temporary unless you send the SAVE command.

Step 10: Lock out calibration

To lock out further calibration, send the following command after completing the calibration procedure:

```
:CAL:PROT:LOCK
```

3

Routine Maintenance

Introduction

The information in this section deals with routine type maintenance that can be performed by the operator and includes information on line fuse replacement.

Line fuse replacement

WARNING Disconnect the line cord at the rear panel, and remove all test leads connected to the instrument before replacing the line fuse.

The power line fuse is accessible from the rear panel and is integral with the AC power module (see [Figure 3-1](#)).

Figure 3-1
Model 2520 rear panel

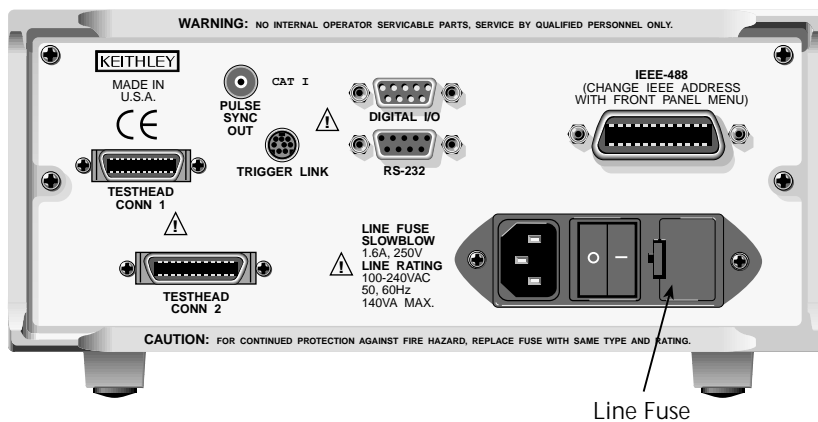

Perform the following steps to replace the line fuse:

1. Using a small flat-blade screwdriver, carefully release the locking tab that secures the fuse carrier to the power module.
2. Pull out the fuse carrier, and replace the fuse with the type specified in [Table 3-1](#).

CAUTION To prevent instrument damage, use only the fuse rating and type specified in [Table 3-1](#).

3. Re-install the fuse carrier, pushing it in firmly until it locks into place.

NOTE If the power line fuse continues to blow, a circuit malfunction exists and must be corrected. Refer to the troubleshooting information in Section 4 of this manual for additional information.

Table 3-1
Power line fuse

Line voltage	Fuse rating	Keithley part no.
100-240V	1.6A slow blow, 250V, 5 × 20mm	FU-106-1.6

4

Troubleshooting

Introduction

This section of the manual will assist you in troubleshooting and repairing the Model 2520 Pulsed Laser Diode Test System. Included are self-tests, test procedures, troubleshooting tables, and circuit descriptions. Note that disassembly instructions are located in Section 5, and component layout drawings are at the end of Section 6.

Safety considerations

WARNING The information in this section is intended for qualified service personnel only. Do not perform these procedures unless you are qualified to do so. Some of these procedures may expose you to hazardous voltages that could cause personal injury or death. Use caution when working with hazardous voltages.

Repair considerations

Before making any repairs to the Model 2520, be sure to read the following considerations.

CAUTION The PC-boards are built using surface mount techniques and require specialized equipment and skills for repair. If you are not equipped and/or qualified, it is strongly recommended that you send the unit back to the factory for repairs or limit repairs to the PC-board replacement level. Without proper equipment and training, you could damage a PC-board beyond repair.

- Repairs will require various degrees of disassembly. However, it is recommended that the Front Panel Tests be performed prior to any disassembly. The disassembly instructions for the Model 2520 are contained in Section 5 of this manual.
- Do not make repairs to surface mount PC-boards unless equipped and qualified to do so (see previous CAUTION).
- When working inside the unit and replacing parts, be sure to adhere to the handling precautions and cleaning procedures explained in Section 5.
- Many CMOS devices are installed in the Model 2520. These static-sensitive devices require special handling as explained in Section 5.
- Whenever a circuit board is removed or a component is replaced, the Model 2520 must be recalibrated. See Section 2 for details on calibrating the unit.

Power-on self-test

During the power-on sequence, the Model 2520 will perform a checksum test on its EPROM and test its RAM. If one of these tests fails, the instrument will lock up.

Front panel tests

There are three front panel tests: one to test the functionality of the front panel keys and two to test the display. In the event of a test failure, refer to Display board checks for details on troubleshooting the display board.

KEYS test

The KEYS test lets you check the functionality of each front panel key. Perform the following steps to run the KEYS test.

1. Display the MAIN MENU by pressing the MENU key.
2. Using the EDIT keys, select TEST, and press ENTER to display the SELF-TEST MENU.
3. Select DISPLAY-TESTS, and press ENTER to display the following menu:
FRONT PANEL TESTS
KEYS DISPLAY-PATTERNS CHAR-SET
4. Select KEYS, and press ENTER to start the test. When a key is pressed, the label name for that key will be displayed to indicate that it is functioning properly. When the key is released, the message “No keys pressed” is displayed.
5. Pressing EXIT tests the EXIT key. However, the second consecutive press of EXIT aborts the test and returns the instrument to the SELF-TEST MENU. Continue pressing EXIT to back out of the menu structure.

DISPLAY PATTERNS test

The display test lets you verify that each pixel and annunciator in the vacuum fluorescent display is working properly. Perform the following steps to run the display test:

1. Display the MAIN MENU by pressing the MENU key.
2. Select TEST, and press ENTER to display the SELF-TEST MENU.
3. Select DISPLAY-TESTS, and press ENTER to display the following menu:
FRONT PANEL TESTS
KEYS DISPLAY-PATTERNS CHAR-SET
4. Select DISPLAY-PATTERNS, and press ENTER to start the display test. There are five parts to the display test. Each time a front panel key (except EXIT) is pressed, the next part of the test sequence is selected. The five parts of the test sequence are as follows:
 - Checkerboard pattern (alternate pixels on) and all annunciators.
 - Checkerboard pattern and the annunciators that are on during normal operation.
 - Horizontal lines (pixels) of the first digit are sequenced.
 - Vertical lines (pixels) of the first digit are sequenced.
 - Each digit (and adjacent annunciator) is sequenced. All the pixels of the selected digit are on.

5. When finished, abort the display test by pressing EXIT. The instrument returns to the FRONT PANEL TESTS MENU. Continue pressing EXIT to back out of the menu structure.

CHAR SET test

The character set test lets you display all characters. Perform the following steps to run the character set test:

1. Display the MAIN MENU by pressing the MENU key.
2. Select TEST, and press ENTER to display the SELF-TEST MENU.
3. Select DISPLAY-TESTS, and press ENTER to display the following menu:
FRONT PANEL TESTS
KEYS DISPLAY-PATTERNS CHAR-SET
4. Select CHAR-SET, and press ENTER to start the character set test. Press any key except EXIT to cycle through all displayable characters.
5. When finished, abort the character set test by pressing EXIT. The instrument returns to the FRONT PANEL TESTS MENU. Continue pressing EXIT to back out of the menu structure.

Principles of operation

The following information is provided to support the troubleshooting tests and procedures covered in this section of the manual. Refer to the following drawings:

Figure 4-1 — Overall block diagram

Figure 4-2 — Analog circuitry block diagram

Figure 4-3 — Power supply block diagram

Figure 4-4 — Digital circuitry block diagram

Overall block diagram

Figure 4-1 shows an overall block diagram of the Model 2520. Circuitry may be divided into two general areas:

- Analog circuits — includes measurement circuits for voltage, and I-V converter for current, A/D converters, and voltage bias and current source circuits.
- Digital circuits — includes the microcomputer that controls the analog section, front panel, and GPIB and RS-232 ports, the DSP (digital signal processor), and associated interfacing and data storage circuits.

Figure 4-1
Overall block diagram

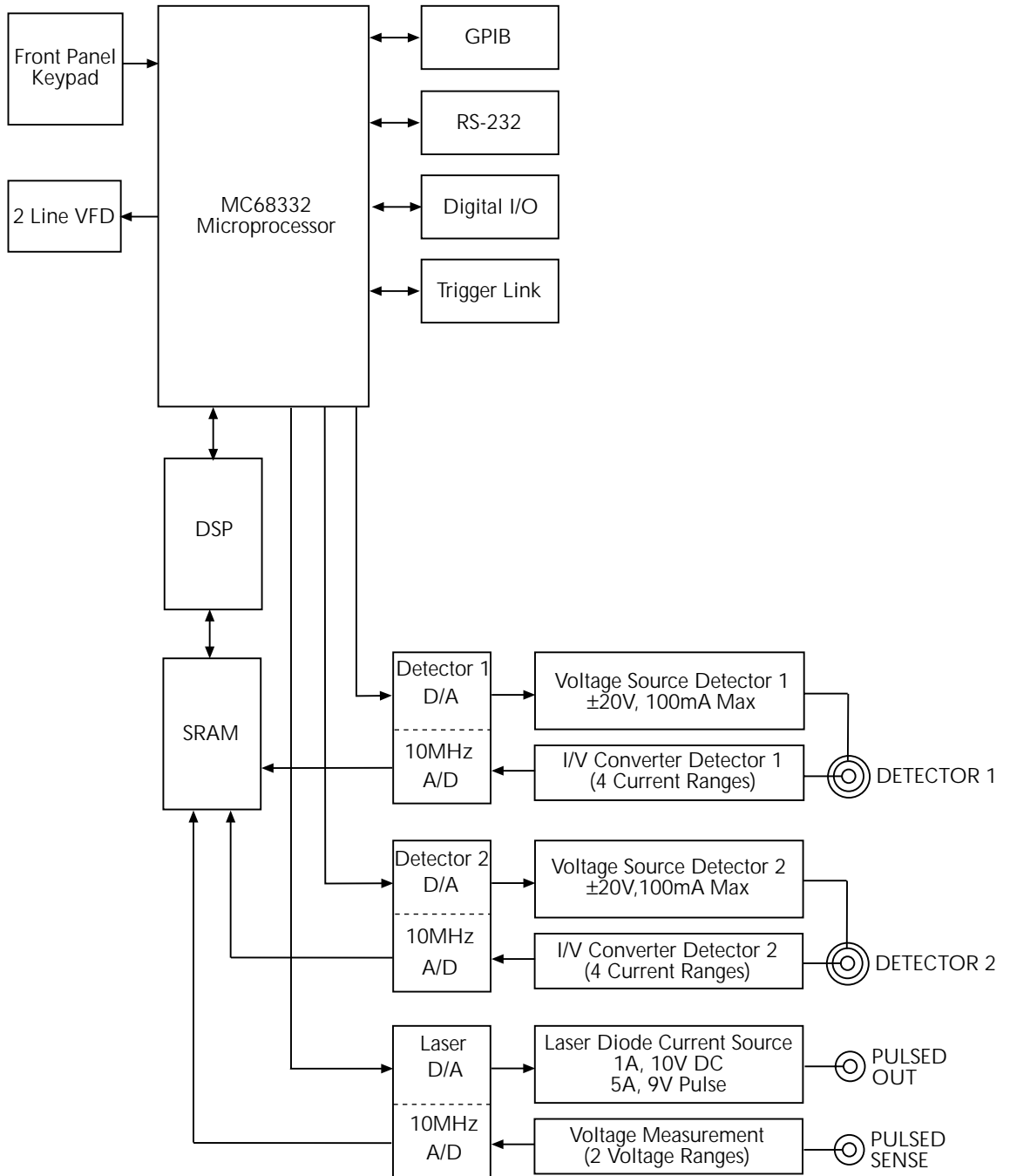

Analog circuits

Figure 4-2 shows a simplified block diagram of the analog circuits.

Measurement circuits

Voltage measurement circuits

The laser diode voltage measurement circuits consist of U12, U13, and associated circuitry. The two sections of U12 provide buffering for the HI and LO sense lines, while U13 controls ranging with appropriate feedback elements.

Current measurement circuits

Signal conditioning for the detector input currents are provided by I-V converters, which convert the input signal currents to voltages that can be used by the A/D converters. U7, U8, Q10, and Q11 form a compound op amp for detector #1 I-V conversion, while U10, U17, Q15, and Q16 make up an identical op amp for detector #2 I-V conversion. Current ranging is provided by selecting various feedback resistors for the corresponding current ranges (10mA, 20mA, 50mA, and 100mA).

A/D converters

Each of the three measurement channels has its own 10MHz, 14-bit A/D converter. U31 provides A/D conversion for laser diode voltage measurements, while U43 and U53 perform A/D conversion for detector 1 and detector 2 current measurements, respectively. A/D digital data is stored in high-speed FIFO (first-in, first-out) SRAM circuits (U27, U29, U38-U42, and U49) for use by the DSP section (described below).

Figure 4-2
Analog circuitry block diagram

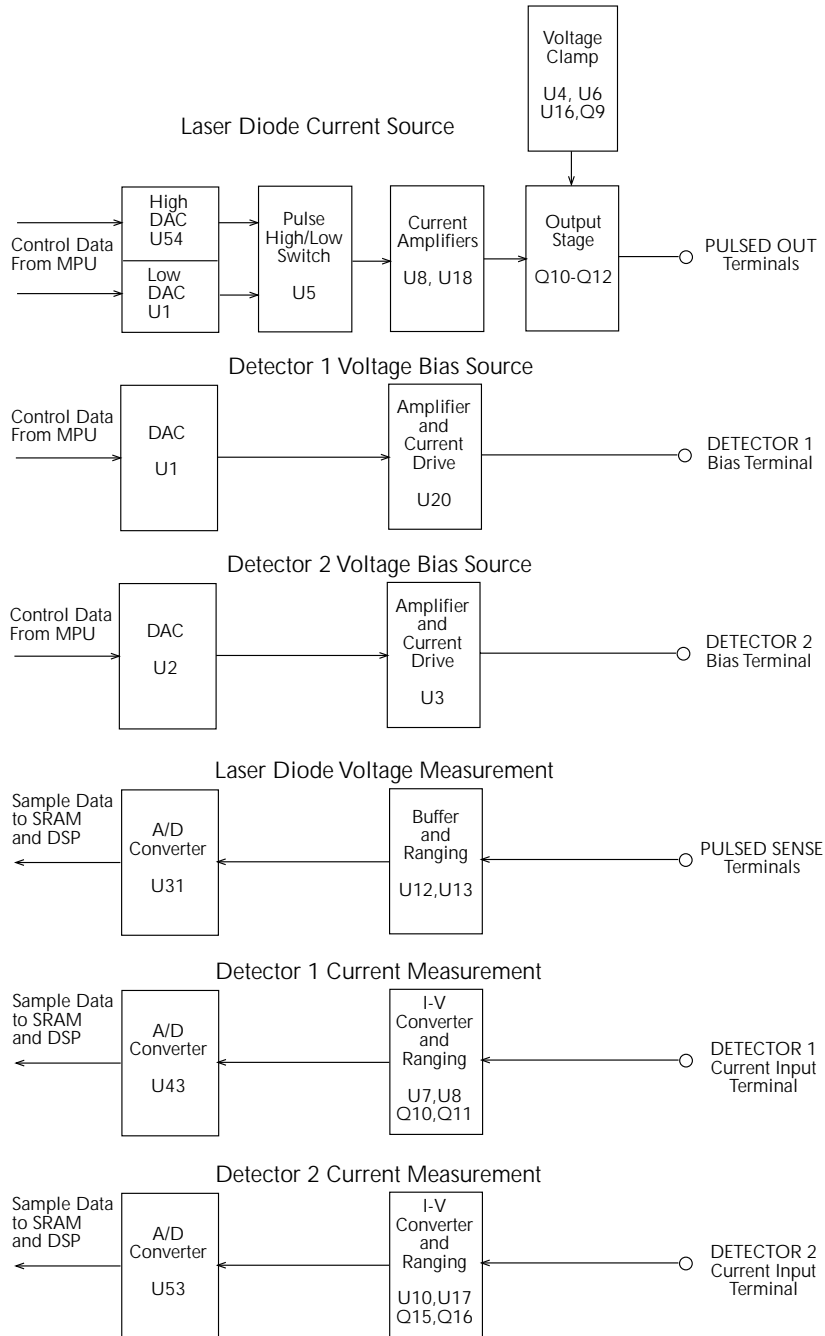

Source circuits

Voltage bias source circuits

Each Model 2520 voltage bias source is a digitally controlled source that can source up to $\pm 20\text{V}$ @ 100mA . Digital control information from the MPU is converted by a DAC into an equivalent analog signal. U1 converts the detector 1 source data, while U2 converts detector 2 source data. Gain and 100mA drive capability for detector 1 and detector 2 sources, respectively, are provided by U20 and U3 to provide the full $\pm 20\text{V}$, 100mA output capability for each source.

Current pulse source circuits

The Model 2520 current source can output a maximum current of 1A DC @ 10V (10W) or 5A @ 9V (45W) current pulses.

DC and pulse high current source data from the MPU is converted into an analog signal by a 16-bit DAC made up of U54 and associated components. Pulse low data is converted by DAC U1, and U5 performs pulse high/low switching. The signal from U5 is amplified by the current amplifiers, U8 and U18, and applied to the output stage (Q10 - Q12), which provides the current drive capability for the current source.

The voltage clamp circuit made up of U4, U6, U16, and Q9 maintains the output voltage at the programmed compliance value regardless of load, while the compliance detection circuit made up of U9 and U19 provides feedback to the MPU for an over-compliance condition. Over temperature detection for the current source is performed by RT1, R46, U15, and associated components.

Power supply

Figure 4-3 shows a block diagram of the Model 2520 power supply system. The supply has two separate power transformers, T1 and T2, as well as both regulated and unregulated supply voltages.

Unregulated circuits include the -8VF1 supply and -25VF1 supply that powers the output stage. Regulated circuits include $\pm 5VFA$, $\pm 12VF$, $+12VD$, and $\pm 25VF$ supplies to power the various circuits throughout the instrument.

Figure 4-3
Power supply block diagram

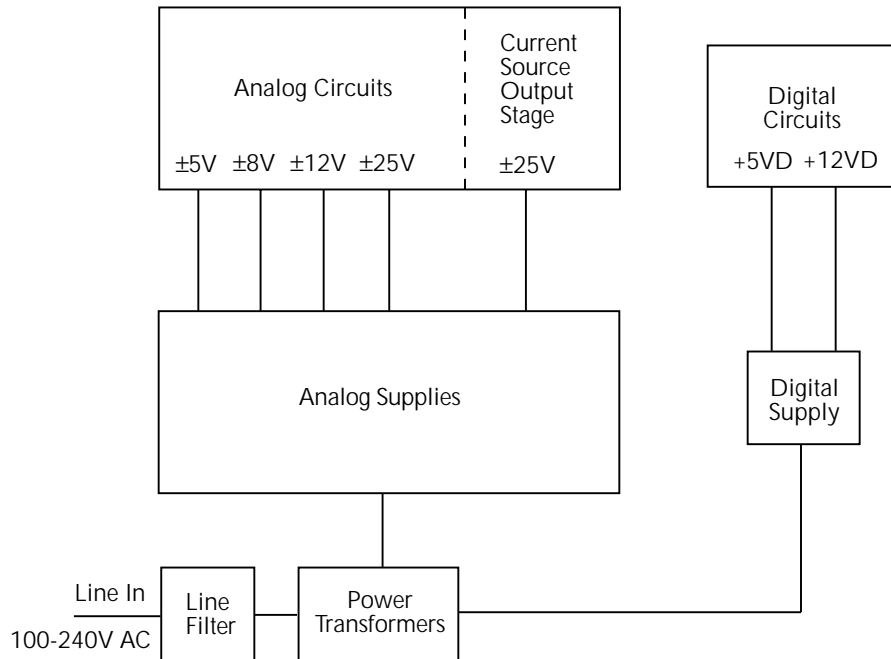

Digital circuitry

Refer to [Figure 4-4](#) for the following discussion on digital circuitry.

Microcontroller

The core digital circuitry uses a Motorola 68332 microcontroller (U15) running at 16.78MHz. The memory configuration includes a flash EEPROM (U3 and U4) and a RAM U2 and U17). Flash ROM support allows internal firmware upgrades using either the serial or GPIB port for downloading new firmware. All calibration constants and the saved setups are stored in a separate serial EEPROM (U13).

I/O circuits

External communication is provided via GPIB and serial interfaces. A 9914 GPIB IEEE-488 standard interface IC is used for the GPIB (U5), and an IC (U20) provides the voltage conversion for the RS-232 port. U35 provides interfacing for the Digital I/O port, while U46 and Q6-Q11 provide Trigger Link I/O interfacing.

Digital signal processor

U47 is the DSP IC that processes raw voltage and current samples into final readings. Voltage and current data for the DSP is read from the high-speed FIFO (first-in, first-out) SRAM circuits (U27, U29, U38-U42, and U49) after being stored there by the A/D converters.

Display board circuits

The display board includes a microcontroller (U902) that controls the VFD (vacuum fluorescent display) and interprets key data. The microcontroller has four peripheral I/O ports that are used for the various control and read functions.

The VFD (vacuum fluorescent display) module (DS901) can display up to 49 characters. Each character is organized as a 5×7 matrix of dots or pixels and includes a long under-bar segment to act as a cursor. The display uses a common multiplexing scheme with each character refreshed in sequence. Circuitry includes the grid drivers and dot drivers.

Figure 4-4
Digital circuitry block diagram

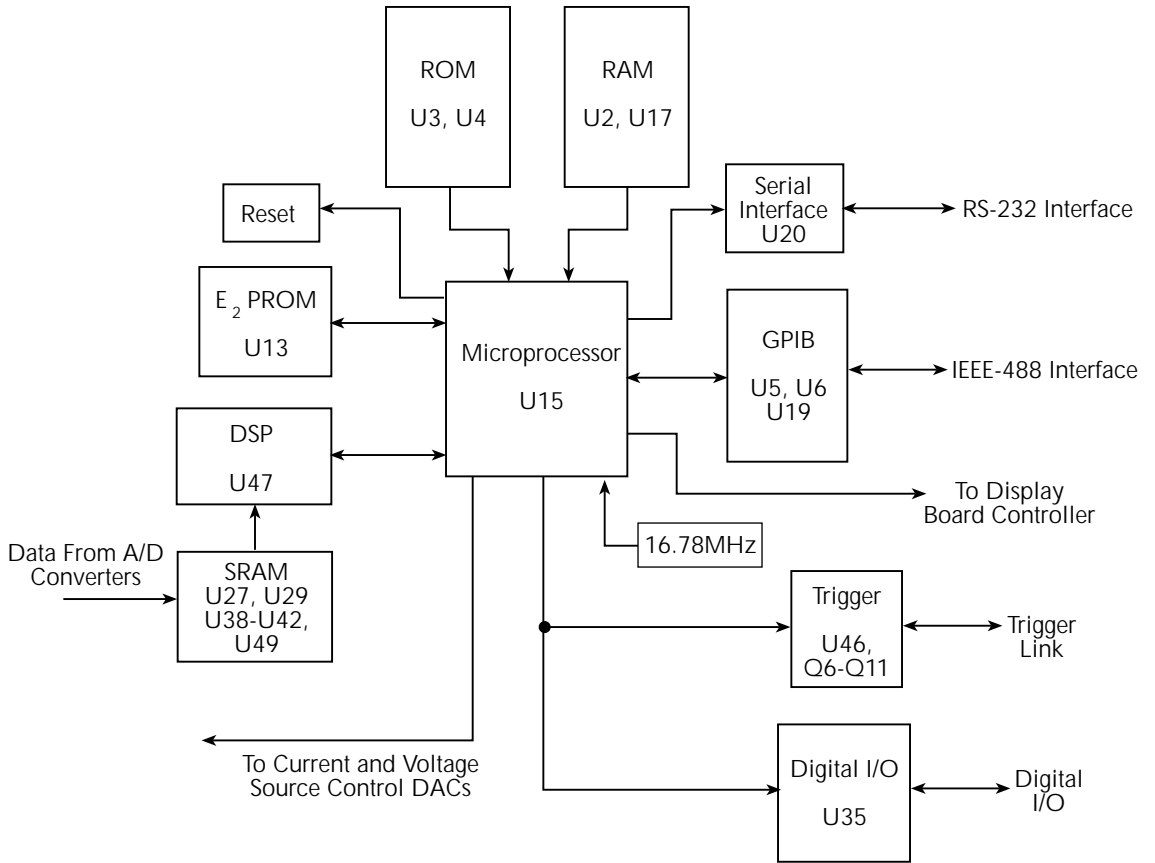

Troubleshooting

Troubleshooting information for the various circuits is summarized below. Refer to the component layout drawings at the end of Section 6 for component locations.

Display board checks

If the front panel display tests indicate that there is a problem on the display board, use [Table 4-1](#). See *Principles of operation* for display circuit theory.

Table 4-1

Display board checks

Step	Item/ component	Required condition	Remarks
1	Front panel test	Verify that all segments operate.	Use front panel display test.
2	J1033	+5V, $\pm 5\%$	Digital +5V supply.
3	U902, pin 1	Goes low briefly on power up, and then goes high.	Microcontroller RESET.
4	U902, pin 43	4MHz square wave.	Controller 4MHz clock.
5	U902, pin 32	Pulse train every 1 ms.	Control from main processor.
6	U902, pin 33	Brief pulse train when front panel key is pressed.	Key down data sent to main processor.

Power supply checks

Power supply problems can be checked out using [Table 4-2](#). See *Principles of operation* for circuit theory on the power supply.

Table 4-2

Power supply checks

Step	Item/ component*	Required condition	Remarks
1	Line fuse	Check continuity.	Remove to check.
2	Line power	Plugged into live receptacle, power on.	Check for correct power-up sequence.
3	TP1	+25V, $\pm 10\%$	Referenced to jumper W3.
4	TP2	-25V, $\pm 10\%$	Referenced to jumper W3.
5	TP14	+25V, $\pm 5\%$	Referenced to jumper W3.
6	TP15	+12V, $\pm 5\%$	Referenced to jumper W3.
7	TP16	+5V, $\pm 5\%$	Referenced to jumper W3.
8	TP20	+5V, $\pm 5\%$	Referenced to jumper W3.
9	TP21	-5V, $\pm 5\%$	Referenced to jumper W3.
10	TP22	+12V, $\pm 5\%$	Referenced to jumper W3.
11	TP23	-12V, $\pm 5\%$	Referenced to jumper W3.
12	TP32	+3.3V, $\pm 5\%$	Referenced to jumper W3.

* Test points (TP) are marked on circuit boards.

Digital circuitry checks

Digital circuit problems can be checked out using [Table 4-3](#). See *Principles of operation* for a digital circuit description.

Table 4-3

Digital circuitry checks

Step	Item/ component	Required condition	Remarks
1	Power-on test	RAM OK, ROM OK.	Verify that RAM and ROM are functional.
2	Clip W2	Digital common.	All signals referenced to digital common.
3	U15 pin 7	+5V	Digital logic supply.
4	U15 pin 68	Low on power-up, then goes high.	MPU RESET line.
5	U15, A0-A18	Check for stuck bits.	MPU address bus.
6	U15, D0-D15	Check for stuck bits.	MPU data bus.
7	U15 pin 66	16.78MHz.	MPU clock.
8	U20 pin 7	Pulse train during RS-232 I/O.	RS-232 TX line.
9	U20 pin 8	Pulse train during RS-232 I/O.	RS-232 RX line.
10	U5 pins 34-42	Pulse train during IEEE-488 I/O.	IEEE-488 data bus.
11	U5 pins 26-31	Pulses during IEEE-488 I/O.	IEEE-488 command lines.
12	U5 pin 24	Low with remote enabled.	IEEE-488 REN line.
13	U5 pin 25	Low during interface clear.	IEEE-488 IFC line.
14	U15 pin 43	Pulse train.	D_RETURN_DATA
15	U15 pin 44	Pulse train.	D_SPI_DATA
16	U15 pin 45	Pulse train.	D_SPI_CLK
17	U15 pin 47	Pulse train.	D_SPI_STB

Analog circuitry checks

Table 4-4 summarizes analog circuitry checks.

Table 4-4

Analog circuitry checks

Step	Item/component	Required condition	Remarks
1	DETECTOR 1 jack	Apply +20mA	Select detector 1 20mA range.
2	TP3	+2.5V*	Detector 1 I-V converter high output.
3	TP4	-2.5V*	Detector 1 I-V converter low output.
4	DETECTOR 2 jack	Apply +20mA	Select detector 2 20mA range.
5	TP17	+2.5V*	Detector 2 I-V converter high output.
6	TP18	-2.5V*	Detector 2 I-V converter low output.
7	PULSED SENSE jacks	Apply +10V	Input 10V to V measure circuit.
8	LASER V_L range	Select 10V range	
9	TP5	-2.5V*	V measure high output.
10	TP6	+2.5V*	V measure low output.
11	Bias source 1	Set to +20V	Output +20V bias value.
12	U20, pin 6	+20V*	Bias source #1 output.
13	Bias source 2	Set to +20V	Output +20V bias value.
14	U3, pin 6	+20V*	Bias source #2 output.
15	LASER I_L source	500mA range	Set to 500mA range, DC mode.
16	LASER I_L source	500mA output	Output 500mA.
17	TP40	+10V**	I source pulse high DAC output.
18	TP7	+1.4V*	Current amplifier input.

*Referenced to TP6, OUTPUT ON.

**Referenced to M20, OUTPUT ON.

No comm link error

A “No Comm Link” error indicates that the front panel display processor has stopped communicating with the main processor, which is located on the motherboard. This error indicates that the main processor ROMs (U3 and U4) may require re-seating in their sockets. The ROMs may be reseated as follows:

1. Turn off the power, and disconnect the line cord and all other test leads and cables from the instrument.
2. Remove the case cover as outlined in Section 5.
3. Locate the firmware ROMs, U3 and U4, located on the motherboard. These ROMs are the only IC installed in a socket. (Refer to the component layout drawing at the end of Section 6 for exact location.)
4. Carefully push down on the ROM ICs to make sure it is properly seated in its socket.

CAUTION Be careful not to push down excessively. The motherboard could crack.

5. Connect the line cord, and turn on the power. If the problem persists, additional troubleshooting will be required.

5 Disassembly

Introduction

This section explains how to handle, clean, and disassemble the Model 2520 Pulsed Laser Diode Test System. Disassembly drawings are located at the end of this section.

Handling and cleaning

To avoid contaminating PC board traces with body oil or other foreign matter, avoid touching the PC board traces while you are repairing the instrument. Certain board areas have high-impedance devices or sensitive circuitry where contamination could cause degraded performance.

Handling PC boards

Observe the following precautions when handling PC boards:

- Wear cotton gloves.
- Only handle PC boards by the edges and shields.
- Do not touch any board traces or components not associated with repair.
- Do not touch areas adjacent to electrical contacts.
- Use dry nitrogen gas to clean dust off PC boards.

Solder repairs

Observe the following precautions when you must solder a circuit board:

- Use an OA-based (organic activated) flux, and take care not to spread the flux to other areas of the circuit board.
- Remove the flux from the work area when you have finished the repair by using pure water with clean, foam-tipped swabs or a clean soft brush.
- Once you have removed the flux, swab only the repair area with methanol, then blow-dry the board with dry nitrogen gas.
- After cleaning, allow the board to dry in a 50°C, low-humidity environment for several hours.

Static sensitive devices

CMOS devices operate at very high impedance levels. Therefore, any static that builds up on you or your clothing may be sufficient to destroy these devices if they are not handled properly. Use the following precautions to avoid damaging them:

CAUTION Many CMOS devices are installed in the Model 2520. Handle all semiconductor devices as being static sensitive.

- Transport and handle ICs only in containers specially designed to prevent static build-up. Typically, you will receive these parts in anti-static containers made of plastic or foam. Keep these devices in their original containers until ready for installation.
- Remove the devices from their protective containers only at a properly grounded work station. Also, ground yourself with a suitable wrist strap.
- Handle the devices only by the body; do not touch the pins.
- Ground any printed circuit board, into which a semiconductor device is to be inserted, to the bench or table.
- Use only anti-static type desoldering tools.
- Use only grounded-tip solder irons.
- Once the device is installed in the PC board, it is normally adequately protected, and you can handle the boards normally.

Assembly drawings

Use the assembly drawings located at the end of this section to assist you as you disassemble and re-assemble the Model 2520. Also, refer to these drawings for information about the Keithley part numbers of most mechanical parts in the unit.

Case cover removal

Follow the steps below to remove the case cover to gain access to internal parts.

WARNING Before removing the case cover, disconnect the line cord and any test leads from the instrument.

1. **Remove handle** — The handle serves as an adjustable tilt-bail. Adjust its position by gently pulling it away from the sides of the instrument case and swinging it up or down. To remove the handle, swing the handle below the bottom surface of the case and back until the orientation arrows on the handles line up with the orientation arrows on the mounting ears. With the arrows lined up, pull the ends of the handle away from the case.
2. **Remove mounting ears** — Remove the screw that secures each mounting ear. Pull down and out on each mounting ear.

NOTE When re-installing the mounting ears, make sure to mount the right ear to the right side of the chassis, and the left ear to the left side of the chassis. Each ear is marked “RIGHT” or “LEFT” on its inside surface.

3. **Remove rear bezel** — To remove the rear bezel, loosen the two screws that secure the rear bezel to the chassis, then pull the bezel away from the case.
4. **Remove bottom screws** — Remove the six screws that secure the case to the chassis. They are located on the bottom of the case.
5. **Remove chassis** — To remove the case, grasp the front bezel of the instrument, and carefully slide the chassis forward. Slide the chassis out of the metal case.

Motherboard removal

Perform the following steps to remove the motherboard. This procedure assumes that the case cover is already removed.

1. Remove the IEEE-488, DIGITAL I/O, RS-232, and TESTHEAD CONN 1 fasteners. The IEEE-488, DIGITAL I/O, RS-232, and TESTHEAD CONN 1 connectors each have two screws that secure the connectors to the rear panel. Remove these screws.
2. Remove the motherboard mounting screws. Remove the five mounting screws that secure the motherboard to the chassis.

3. Unplug cables:
 - Unplug the ribbon cables from J1007 and J1033.
 - Unplug the cable going to the power supply module from J1011.
 - Unplug the cable going to the OUTPUT indicator from J1034.
 - Unplug the wires going to the rear panel PULSE SYNC OUT jack from J1006.
4. Remove the motherboard. Slide the motherboard forward slightly until the rear panel connectors clear the holes in the rear panel, then remove the board. During re-assembly, replace the motherboard, and start the IEEE-488, DIGITAL I/O, RS-232, and TESTHEAD CONN1 connector screws and the board mounting screws. Tighten all the fasteners once they are all in place and the board is correctly aligned. Be sure to plug in all cables.

Front panel disassembly

Use the following procedure to remove the display board and/or the push-button switch pad.

1. Remove the front panel assembly. This assembly has four retaining clips that snap onto the chassis over four pem nut studs. Two retaining clips are located on each side of the front panel. Pull the retaining clips outward and, at the same time, pull the front panel assembly forward until it separates from the chassis.
2. Unplug the display board ribbon cables.
3. Using a thin-bladed screwdriver, pry the plastic PC board stop (located at the bottom of the display board) until the bar separates from the casing. Pull the display board from the front panel.
4. Remove the switch pad by pulling it from the front panel.

Removing power components

The following procedures to remove the power supply and/or power module require that the case cover and motherboard be removed, as previously explained.

Power supply module removal

Perform the following steps to remove the power supply module:

1. Disconnect the wires that connect the power supply module on the bottom of the chassis to the rear panel power module.
2. Remove the screws that secure the power supply to the chassis bottom, then remove the module.

Power module removal

Perform the following steps to remove the rear panel power module:

1. Disconnect the power module's ground wire. This green and yellow wire connects to a threaded stud on the chassis with a kep nut.
2. Squeeze the latches on either side of the power module while pushing the module from the access hole.

Instrument re-assembly

Re-assemble the instrument by reversing the previous disassembly procedures. Make sure that all parts are properly seated and secured, and that all connections are properly made.

WARNING To ensure continued protection against electrical shock, verify that power line ground (green and yellow wire attached to the power module) is connected to the chassis. Also make sure the ground wires are attached to the power transformer mounting screws.

Also ensure the six bottom case screws are properly installed to secure and ground the case cover to the chassis.

Testhead disassembly

Follow the procedures below in the following order to disassemble the testhead.

Case disassembly

1. Remove the eight screws that secure the case top to the case bottom.
2. Remove the nuts and washers that secure the four BNC PULSED and two triax DETECTOR jacks to the front panel.
3. Slide the case top forward until it clears the BNC and triax jacks, then continue sliding the case top forward away from the case bottom.

Output board removal

1. Remove the two screws that secure the REMOTE INTERLOCK connector to the rear panel.
2. Remove the nut that secures the KEY INTERLOCK to the rear panel.
3. Unplug the ribbon cable from J4.
4. Remove the three screws that secure the output board to the standoffs.
5. Pull the output board forward until the KEY INTERLOCK and REMOTE INTERLOCK connector clear the rear panel, then remove the output board.

Input board removal

1. Remove the two screws that secure the MAINFRAME CONN 1 connector to the front panel.
2. Unplug the MAINFRAME CONN 2 ribbon cables from the input board.
3. Unplug the INTERLOCK STATUS and POWER ON indicator light cables from J5 and J6.
4. Remove the screws and standoffs that secure the input board to the case bottom.
5. Pull the input board forward until the MAINFRAME CONN 1 connector clears the rear panel, then carefully remove the input board from the case bottom.

Testhead re-assembly

Re-assemble the testhead by reversing the above procedure. Be sure that all cables are connected, and that all screws, standoffs, and nuts are installed and properly secured.

2520-040

ON

LTR	ECA NO.	REVISION	ENG	DATE
A		Released		

STEP 1

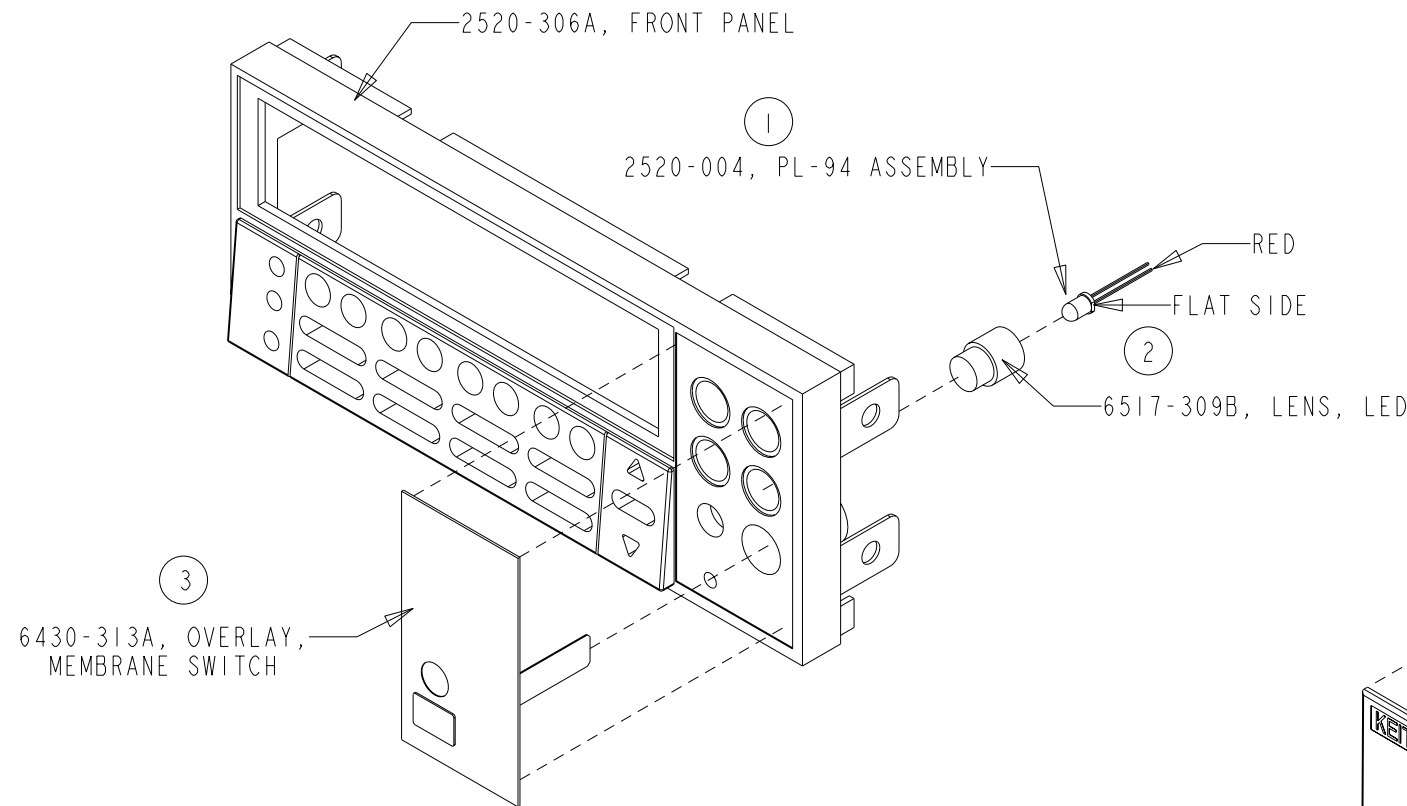

STEP 2

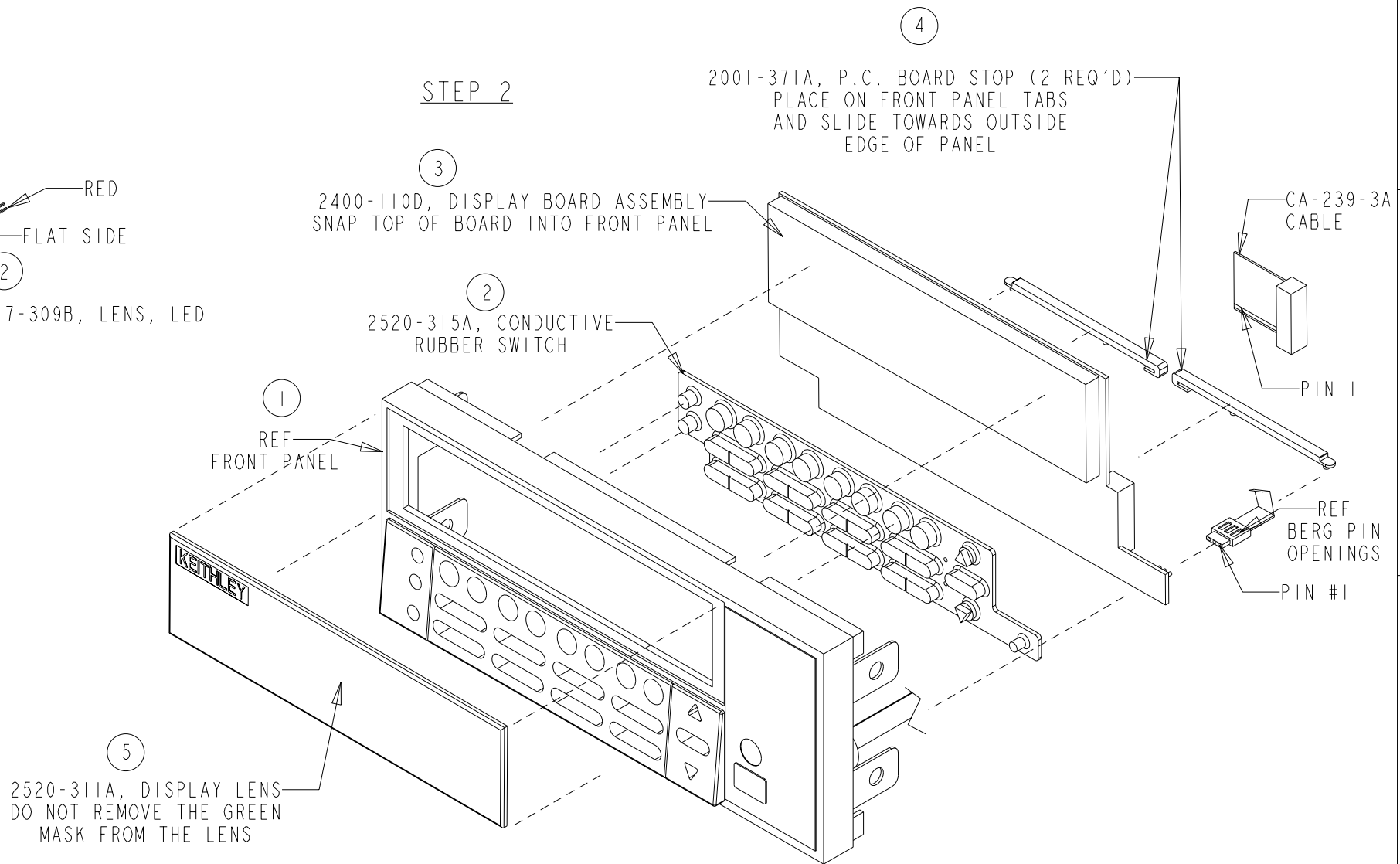

PART NUMBER	QTY	DESCRIPTION
2520-306A	1	FRONT PANEL
2400-110D	1	DISPLAY BOARD ASSEMBLY
6430-313A	1	OVERLAY, MEMBRANE SWITCH
2520-311A	1	DISPLAY LENS
2520-315A	1	CONDUCTIVE RUBBER SWITCH
2001-371A	2	P.C. BOARD STOP
6517-309B	1	LENS, LED
2520-004	1	CRIMP ASSEMBLY
CA-239-3A	1	CABLE

2520	2520-052	Chassis/Analog Board Ass'y	1
MODEL	NEXT ASSEMBLY	NEXT PROCESS STEP	QTY

USED ON

DO NOT SCALE THIS DRAWING		DIMENSIONAL TOLERANCES UNLESS OTHERWISE SPECIFIED		DATE 17-Oct-00	SCALE - - - - -	TITLE	
XX = ±.015		ANG. = ±°		DRN. <i>Mat</i>	ENG APPR.	Front Panel Assembly OP6	
XXX = ±.005		FRAC. = ±1/64		MATERIAL		B	NO. 2520-040
SURFACE MAX. \sqrt{R}		FINISH					

KEITHLEY Keithley Instruments Inc.
Cleveland, Ohio 44139

050-0292

ON

DETAIL A

POWER MODULE WIRING

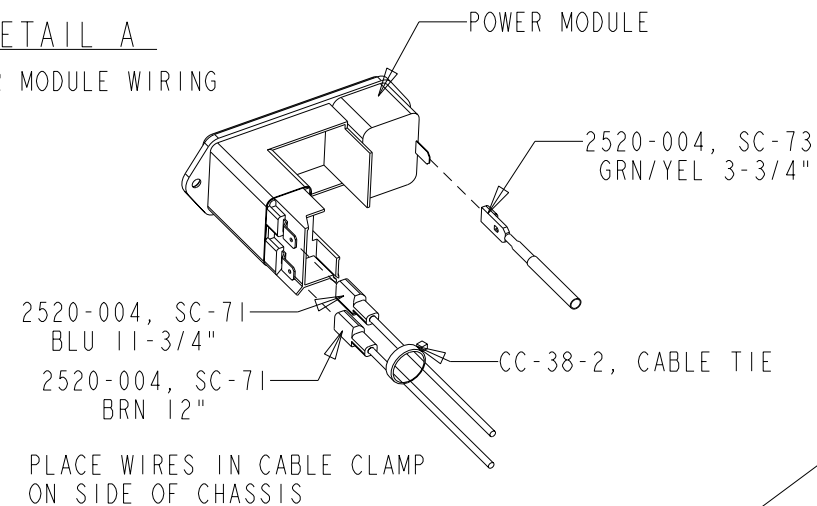

DETAIL B

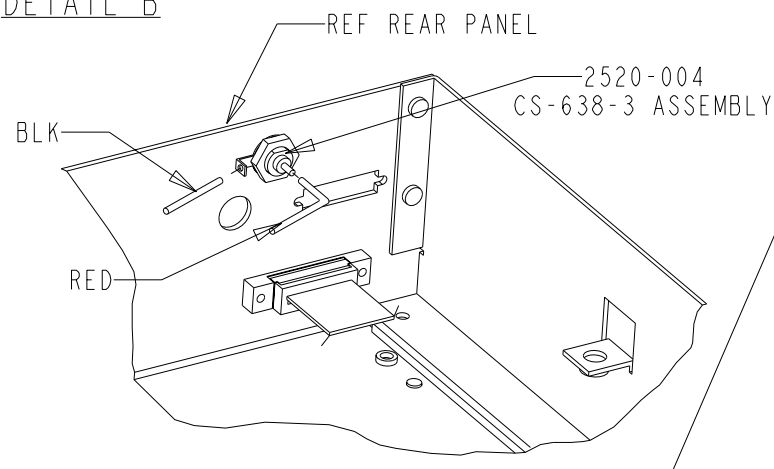

LTR	ECA NO.	REVISION	ENG	DATE
B	26048	Add 2520-330A, T-7972 Was T-7978		

PART NUMBER	QTY	DESCRIPTION
2520-004	1	CRIMP ASSEMBLY
2520-302B	1	CHASSIS
2520-329A	1	BRACKET
CA-266-1B	1	CABLE
CC-37	3	CABLE CLAMP
CS-15	1	CONNECTOR
FE-6	2	FOOT
FH-39	1	FUSE HOLDER
FU-106-1.6	1	FUSE -- 1.6 AMP
LU-100	1	LUG
PM-6-1	1	POWER MODULE
PS-41C	1	POWER SUPPLY
M2.5X8PPH	2	METRIC PHIL PAN HEAD SCREW
4-40X5/16PFH	2	PHIL FLAT HEAD SCREW
4-40X1/4PPH	4	PHIL PAN HEAD SCREW
6-32KEPNUT	1	KEPNUT
4-40KEPNUT	2	KEPNUT
428-319A	2	FOOT
6-32X1/4PFH	2	PHIL FLAT HEAD SCREW
CC-38-2	1	CABLE TIE
FE-12	1	FOOT
2520-330A	1	SAFETY COVER

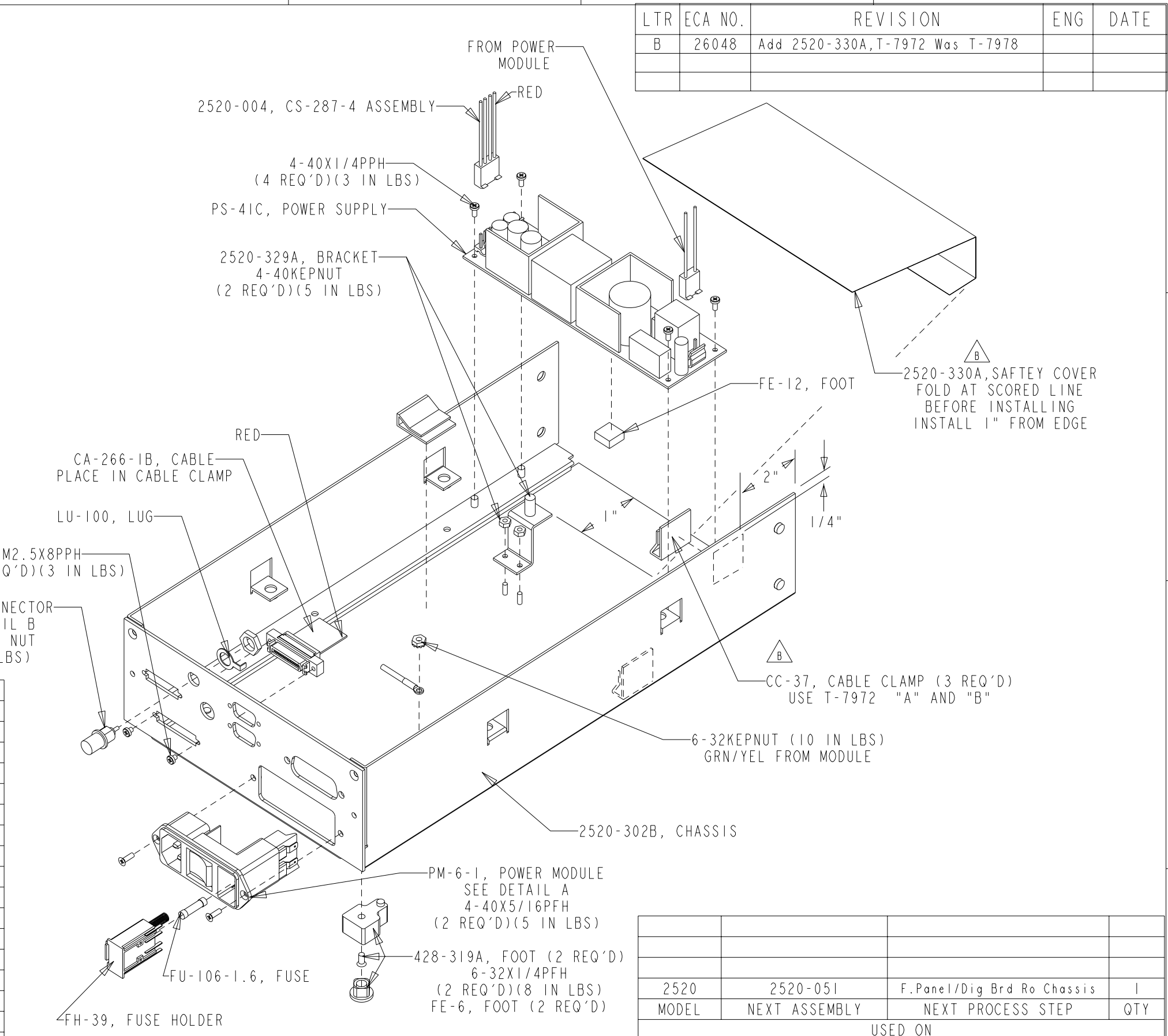

2520	2520-051	F.Panel/Dig Brd Ro Chassis	1
MODEL	NEXT ASSEMBLY	NEXT PROCESS STEP	QTY
USED ON			

DO NOT SCALE THIS DRAWING

DIMENSIONAL TOLERANCES UNLESS OTHERWISE SPECIFIED

XX = ±.015 ANG. = ±°

XXX = ±.005 FRAC. = ±1/64

SURFACE MAX. \sqrt{R}

DATE 19-Oct-00

SCALE - - - - -

TITLE Power Module/Power Supply To Chassis

DRN. *Mat*

ENG APPR. LJS

MATERIAL

FINISH

NO. 2520-050

KEITHLEY Keithley Instruments Inc. Cleveland, Ohio 44139

150-0292

DETAIL A

DIGITAL BOARD WIRING

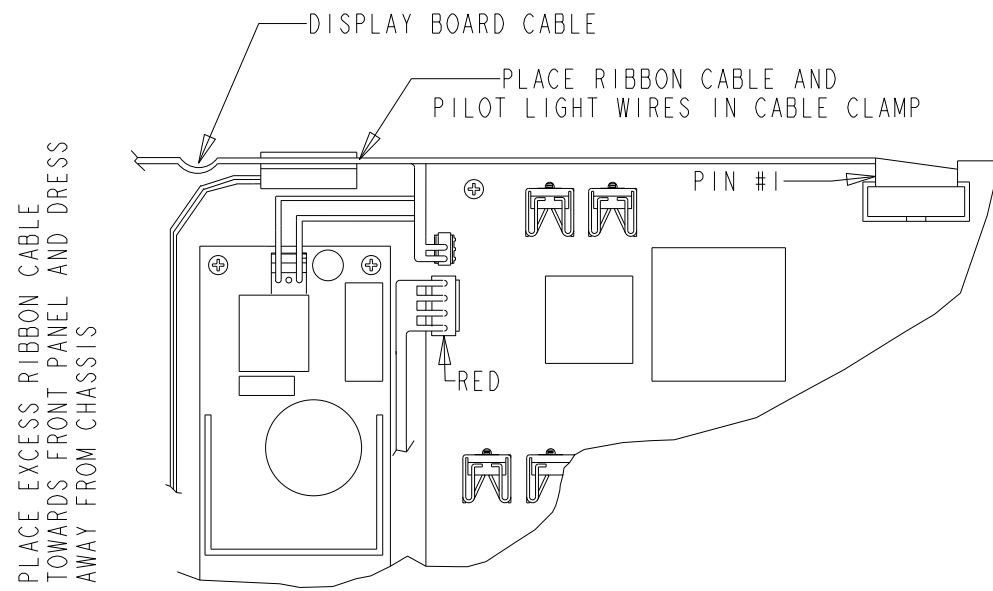

LTR	ECA NO.	REVISION	ENG	DATE
A	25821	Released	ST	4/9/01
A1	26082	2520-100C1 Was 2520-100C	ST	7/10/01
A2	25736	2520-100D Was 2520-100C1		

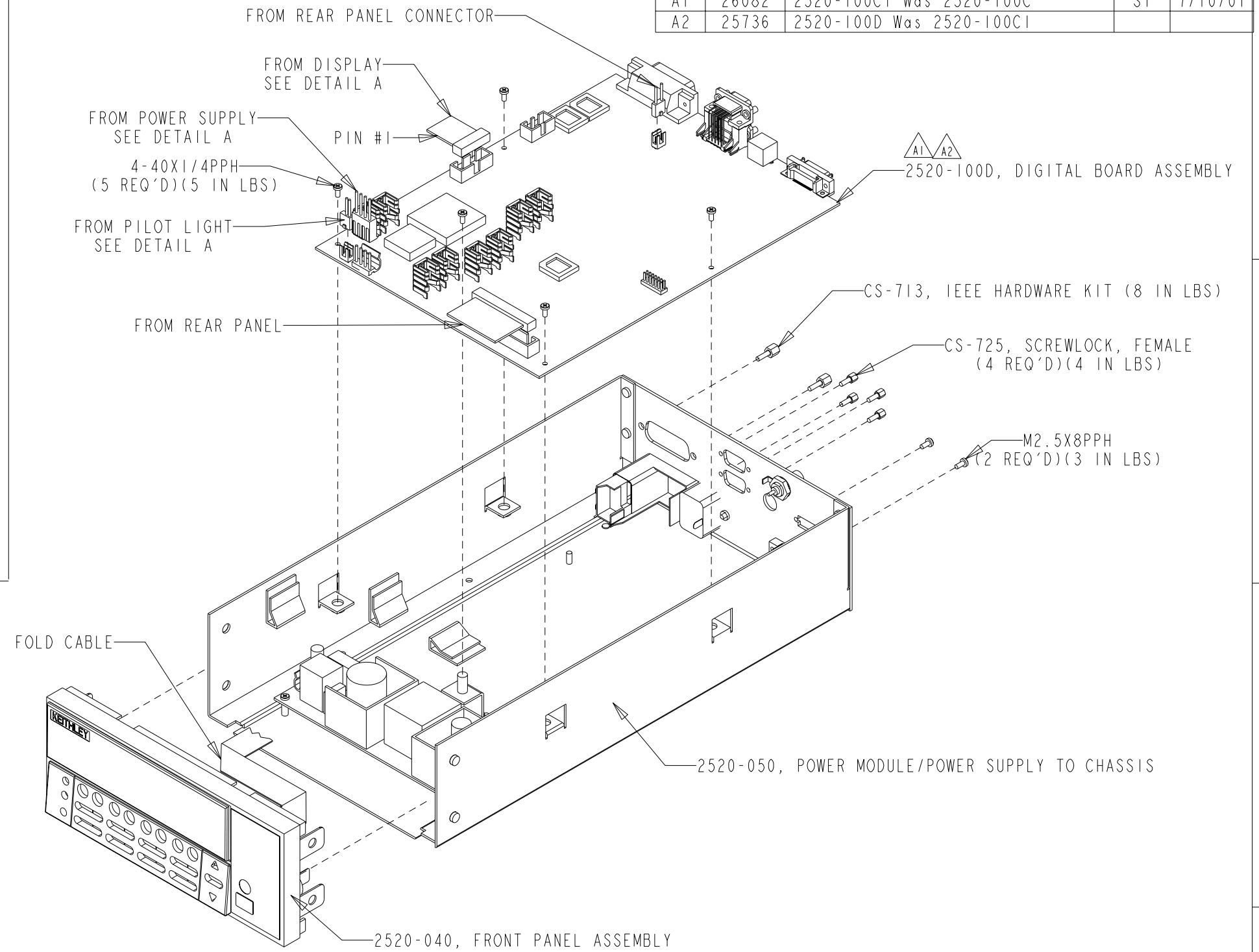

PART NUMBER	QTY	DESCRIPTION
2520-100D	1	DIGITAL BOARD ASSEMBLY
2520-040	1	FRONT PANEL ASSEMBLY
2520-050	1	POWER MODULE/POWER SUPPLY TO CHASSIS
CS-713	1	IEEE HARDWARE KIT
CS-725	4	SCREWLOCK, FEMALE
M2.5X8PPH	2	METRIC PHIL PAN HEAD SCREW
4-40X1/4PPH	5	PHIL PAN HEAD SCREW

A1 A2

2520	2520-052	Chassis Assembly	1
MODEL	NEXT ASSEMBLY	NEXT PROCESS STEP	QTY
USED ON			

DO NOT SCALE THIS DRAWING

DIMENSIONAL TOLERANCES UNLESS OTHERWISE SPECIFIED

XX = ±.015 ANG. = ±1°

XXX = ±.005 FRAC. = ±1/64

SURFACE MAX. \sqrt{R}

DATE 23-Oct-00 SCALE - - - -

DRN. *Mat* ENG APPR. LS

TITLE Front Panel/Dig Board To Chassis

NO. 2520-051

KEITHLEY Keithley Instruments Inc. Cleveland, Ohio 44139

2520-052

ON

LTR	ECA NO.	REVISION	ENG	DATE
B	25944	ADDED CA-265-1B & CA-264-2	ST	4/9/01
BI	25901	2520-300G Was 2520-300F		

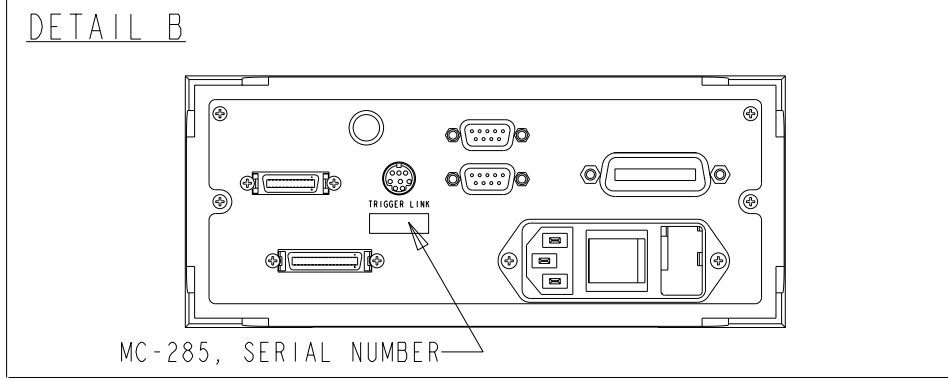
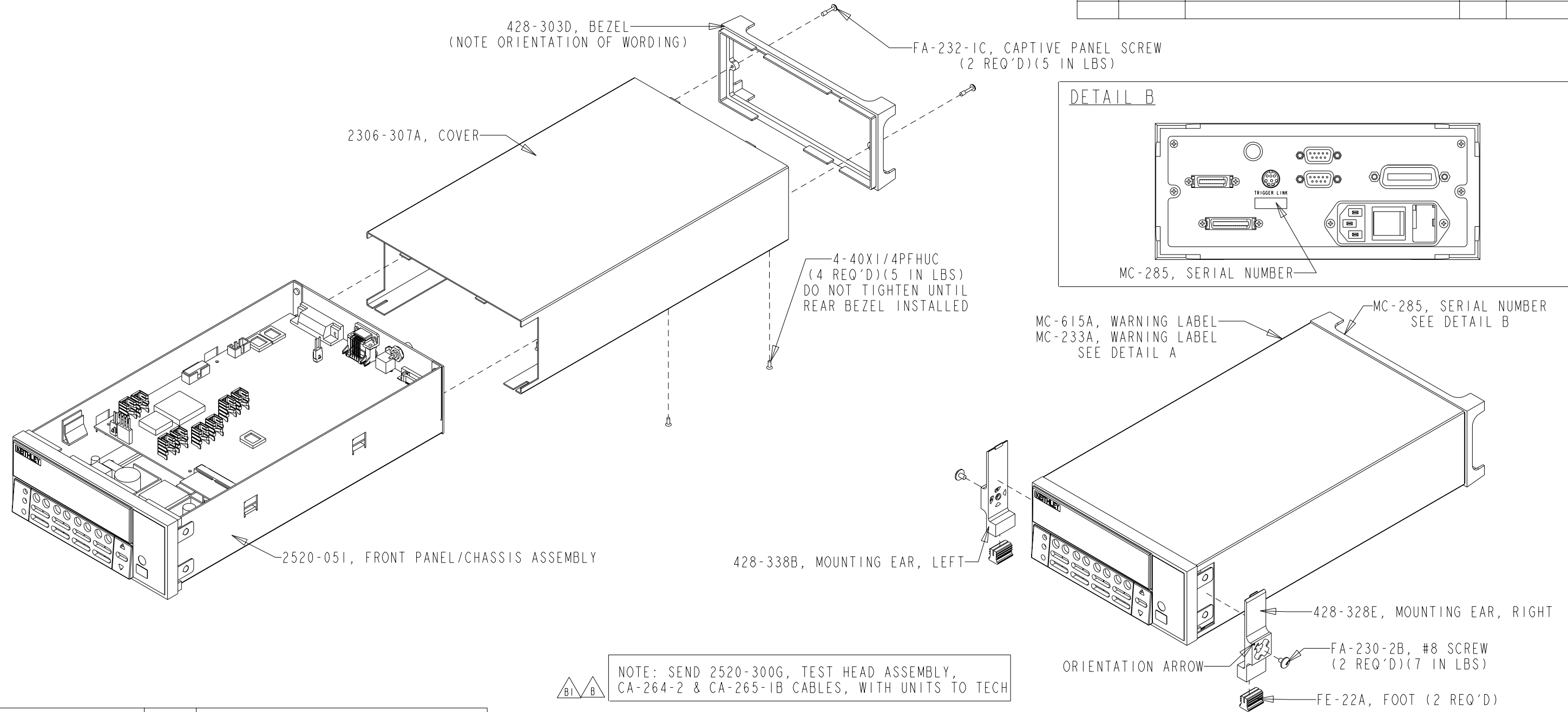

NOTE: SEND 2520-300G, TEST HEAD ASSEMBLY, CA-264-2 & CA-265-1B CABLES, WITH UNITS TO TECH

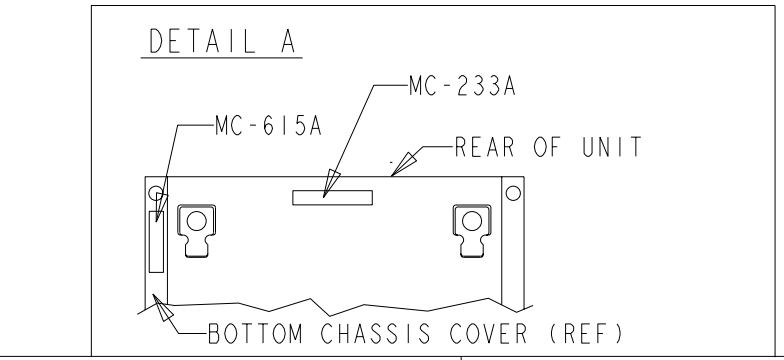

PART NUMBER	QTY	DESCRIPTION
2520-051	1	FRONT PANEL/CHASSIS ASSEMBLY
2306-307A	1	COVER
428-328E	1	MOUNTING EAR, RIGHT
428-338B	1	MOUNTING EAR, LEFT
FA-230-2B	2	FASTENER
FE-22A	2	FOOT
MC-615A	1	WARNING LABEL
4-40X1/4PFHUC	4	PHIL FLAT HEAD UNDERCUT SCREW
428-303D	1	REAR BEZEL
FA-232-1C	2	CAPTIVE PANEL SCREW
MC-233A	1	WARNING LABEL
MC-285	1	SERIAL NUMBER
2520-300G	1	TEST HEAD ASSEMBLY
CA-264-2	1	CABLE
CA-265-1B	1	CABLE

2520	2520-080	Final Inspection	1
2520	Tech	Tech	1
MODEL	NEXT ASSEMBLY	NEXT PROCESS STEP	QTY

DO NOT SCALE THIS DRAWING

DIMENSIONAL TOLERANCES UNLESS OTHERWISE SPECIFIED

XX = ±.015 ANG. = ±1'

XXX = ±.005 FRAC. = ±1/64

SURFACE MAX. √

DATE 24-Oct-00 SCALE - - - - TITLE Chassis Assembly

DRN. *Mat* ENG APPR. LS

MATERIAL FINISH

NO. 2520-052

KEITHLEY Keithley Instruments Inc. Cleveland, Ohio 44139

080-0252

ON

LTR	ECA NO.	REVISION	ENG	DATE
C	25949	Add PA's & Manual's To Part List	ST	7/11/01
CI	26087	CA-290-1B Was CA-290-1A		

Recommended Procedure:

1. Turn the UUT ON.
2. Verify all display segments and annunciators turn ON for a few seconds.
3. Verify Firmware Rev.
4. Verify GPIB Address 25.
5. Verify that front panel displays zero for Ipulse and dashes for Current and Voltage.

To change GPIB Address.

1. Press COMM.
2. Using the Left and Right Arrow Keys, Select GPIB and Press ENTER.
3. Using UP and DOWN Arrow Keys, set Address to 25 and Press ENTER.
4. Using the LEFT and RIGHT Arrow Keys, Select SCPI and Press enter
5. To EXIT, Press EXIT.

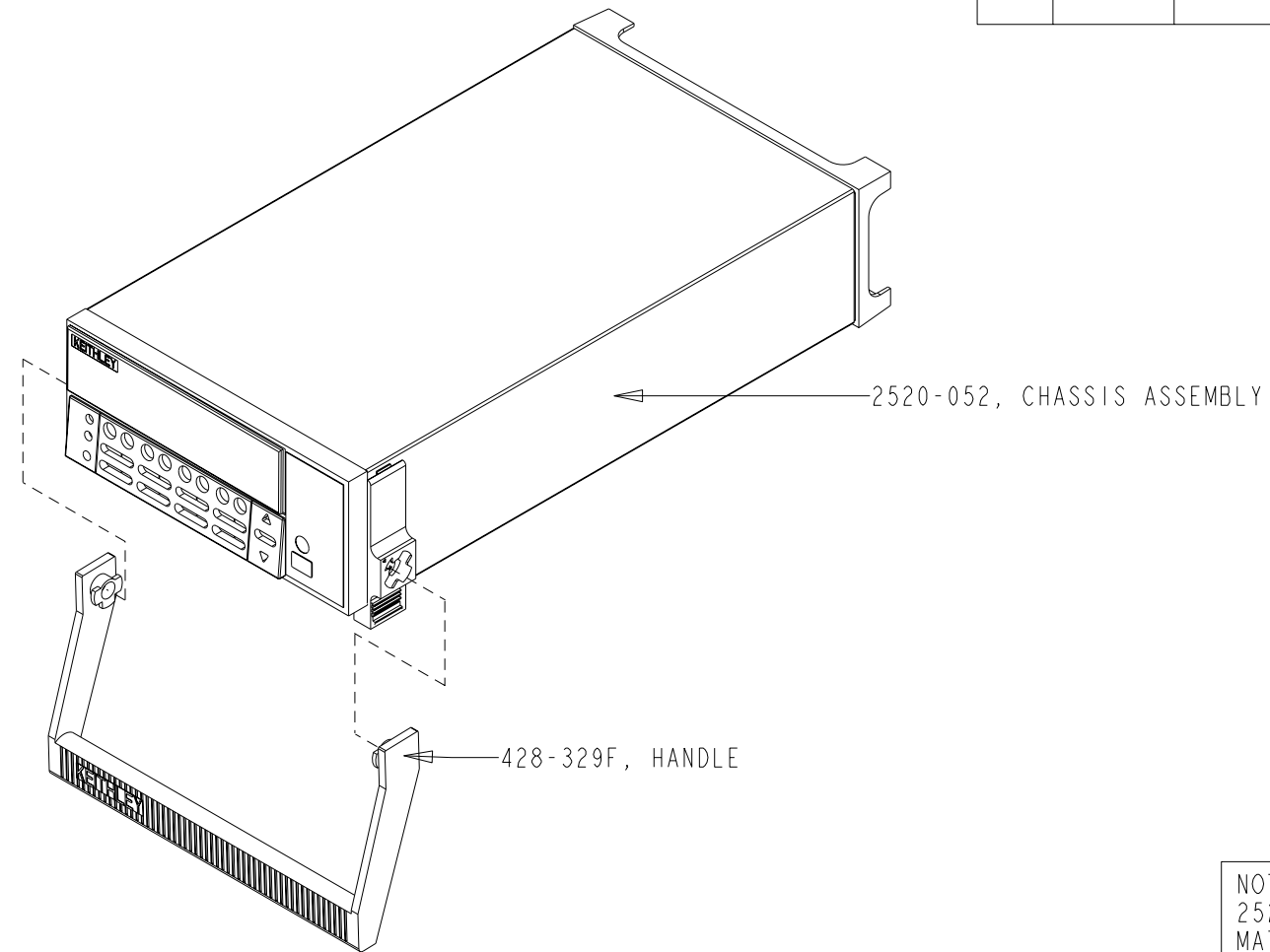

PLACE CERTIFICATE OF CALIBRATION ON TOP OF UNIT, THEN PLACE INTO PO-14-4, CHIPLOC BAG AND SEND WITH W.O. SHIPPING KIT ITEMS TO AUDIT

NOTE: KEEP THE 2520 UNIT AND 2520-300 TEST HEAD ASSEMBLY MATCHED FROM TECH. MUST BE SHIPPED TOGETHER

- NOTE:
1. PLACE THE 2 CABLES FROM TECH IN THE WORK ORDER SHIPPING KIT BAG.
 2. PLACE SWITCH KEY IN THE 8 X 10 BAG FROM 2520-300 ASSEMBLY.

PART NUMBER	QTY	DESCRIPTION
2520-052	1	CHASSIS ASSEMBLY
PO-14-4	1	CHIPLOC BAG
CO-7	1	LINE CORD W.O. SHIPPING KIT
2520-900-00*	1	MANUAL PACKAGE W.O. SHIPPING KIT
-----	1	CERTIFICATE OF CALIBRATION (PA-214 PRINTED IN PRODUCTION)
428-329F	1	HANDLE
CA-289-1A	1	CABLE W.O. SHIPPING KIT
CA-290-1B	1	CABLE W.O. SHIPPING KIT
PA-795A	1	PACKING LIST W.O. SHIPPING KIT
PA-796A	1	PACKING LIST W.O. SHIPPING KIT
PA-797A	1	PACKING LIST W.O. SHIPPING KIT
PA-798A	1	PACKING LIST W.O. SHIPPING KIT
2520-903-00*	1	MANUAL PACKAGE W.O. SHIPPING KIT

NOTE: UNIT IS TO BE SHIPPED WITH GREEN MASK ON THE LENS

PERFORM HIPOT TEST PER MS-1537 TO IEC DC VOLTAGE SPEC

CALL STOCKROOM FOR WORK ORDER SHIPPING KIT BEFORE SENDING TO F.G.S.

2520	Audit	Audit	1
MODEL	NEXT ASSEMBLY	NEXT PROCESS STEP	QTY
USED ON			

DO NOT SCALE THIS DRAWING	DIMENSIONAL TOLERANCES UNLESS OTHERWISE SPECIFIED	DATE 24-Oct-00	SCALE - - - - -	TITLE
Keithley Instruments Inc. Cleveland, Ohio 44139	XX = ±.015 ANG. = ±1°	DRN. <i>Mat</i>	ENG APPR. LS	Final Inspection
	XXX = ±.005 FRAC. = ±1/64	MATERIAL		
	SURFACE MAX. \sqrt{R}	FINISH		
			B	NO. 2520-080

6

Replaceable Parts

Introduction

This section contains replacement parts information and component layout drawings for the Model 2520 Pulsed Laser Diode Test System.

Parts lists

The electrical parts lists for the Model 2520 are shown in tables at the end of this section. For part numbers to the various mechanical parts and assemblies, use the Miscellaneous parts list and the assembly drawings provided at the end of Section 5.

Ordering information

To place an order, or to obtain information concerning replacement parts, contact your Keithley representative or the factory (see inside front cover for addresses). When ordering parts, be sure to include the following information:

- Instrument model number (Model 2520)
- Instrument serial number
- Part description
- Component designation (if applicable)
- Keithley part number

Factory service

If the instrument is to be returned to Keithley Instruments for repair, perform the following:

- Call the Repair Department at 1-800-552-1115 for a Return Material Authorization (RMA) number.
- Complete the service form at the back of this manual, and include it with the instrument.
- Carefully pack the instrument in the original packing carton.
- Write ATTENTION REPAIR DEPARTMENT and the RMA number on the shipping label.

Component layouts

The component layouts for the circuit boards are provided on the following pages.

Table 6-1
Mainframe digital board parts list

Circuit designation	Description	Keithley part no.
C10	CAP, .33UF, 20%, 50V, CERAMIC	C-237-.33
C105,C106,C146,C147,C186,C187	CAP, 22P, 5%, 100V, CERAMIC	C-465-22P
C108	CAP, 1UF, 20%, 35V, TANTALUM	C-494-1
C111	CAP, .1UF, 20%,100V, CERAMIC	C-436-.1
C116	CAP, 10U, 20%, 16V, TANTALUM	C-546-10
C128-C132,C136,C137,C1, C17,C22, C28,C30	CAP, 22U, 20%, 25V, ALUM ELEC	C-609-22
C13,C15,C83-C85	CAP, 220PF, 10%, 100V, CERAMIC	C-451-220P
C133-C135,C60,C63-C65,C67, C72,C76, C82	CAP, .1UF, 20%, 50V, CERAMIC	C-418-.1
C14	CAP, 2200P, 1%, 50V, CERAMIC	C-532-2200P
C140,C141,C169-C171,C178,C179, C182,C183	CAP, 22U, 20%, 25V, ALUM ELEC	C-609-22
C142-C145,C159,C166-C168, C173-C177,C184	CAP, .1UF, 20%, 50V, CERAMIC	C-418-.1
C148-C153	CAP, 1000P, 10%, 100V, CERAMIC	C-451-1000P
C158	CAP, 100U, 20%, 16V, ALUM ELEC	C-547-100
C16,C46-C49,C101,C102,C104, C138,C139	CAP, 100PF, 5%, 100V, CERAMIC	C-465-100P
C172	CAP, 33PF, 5%, 100V, CERAMIC	C-465-33P
C180,C181	CAP, 100PF, 5%, 100V, CERAMIC	C-465-100P
C185,C103,C107,C110,C112,C113, C120-C127	CAP, .1UF, 20%, 50V, CERAMIC	C-418-.1
C189	CAP, .01uF, 20%, 50V, CERAMIC	C-418-.01
C190,C87,C93-C96,C100,C109, C117-C119	CAP, 22U, 20%, 25V, ALUM ELEC	C-609-22
C19-C21,C42-C45,C154,C160, C163-C165,C188	CAP, .01uF, 20%, 50V, CERAMIC	C-418-.01
C202-C205,C207,C210-C214	CAP, .1UF, 20%, 50V, CERAMIC	C-418-.1
C206,C208,C309,C310.C311	CAP, .01uF, 20%, 50V, CERAMIC	C-418-.01
C216,C217,C219,C220,C222, C224-C226,C228	CAP, .1UF, 20%, 50V, CERAMIC	C-418-.1
C218,C221,C223,C279,C281, C283-C286	CAP, .01uF, 20%, 50V, CERAMIC	C-418-.01
C227,C229,C230,C292-C294	CAP, 100P, 10%, 100V, CERAMIC	C-451-100P
C232-C236,C191,C192,C194, C196,C199	CAP, .1UF, 20%, 50V, CERAMIC	C-418-.1

Table 6-1 (continued)
Mainframe digital board parts list

Circuit designation	Description	Keithley part no.
C237	CAP, 1000P, 10%, 100V, CERAMIC	C-451-1000P
C239,C263,C287	CAP, 47P, 5%, 100V, CERAMIC	C-465-47P
C240-C245,C250,C253-C262, C264-C278,C282	CAP, .1UF, 20%, 50V, CERAMIC	C-418-.1
C246,C247,C249,C251,C252	CAP, 220PF, 10%, 100V, CERAMIC	C-451-220P
C25,C41	CAP, 15P, 1%, 100V, CERAMIC	C-512-15P
C26,C114,C155,C157	CAP, 470U, 20%, 25V, ALUM ELEC	C-478-470
C27	CAP, 100P, 10%, 100V, CERAMIC	C-451-100P
C280	CAP, 47PF, 10%, 100V, CERAMIC	C-451-47P
C288-C291,C295-C300,C307, C308,C238	CAP, .1UF, 20%, 50V, CERAMIC	C-418-.1
C301-C306,C193,C195,C197,C198, C200,C201	CAP, .01uF, 20%, 50V, CERAMIC	C-418-.01
C31,C66,C68,C70,C74,C77-C81	CAP, 22U, 20%, 25V, ALUM ELEC	C-609-22
C32,C37,C38,C40,C50-C54,C59, C312-C320	CAP, .1UF, 20%, 50V, CERAMIC	C-418-.1
C33,C35,C36,C57,C58,C61,C62, C71,C75	CAP, 47U, 20%, 50V, ALUM	C-579-47
C34	CAP, 470U, 20%, 50V, ALUM ELEC	C-570-470
C39	CAP, 47PF, 10%, 100V, CERAMIC	C-451-47P
C4,C9,C24	CAP, 22UF, 20%, 25V, TANTALUM	C-440-22
C55,C56	CAP, 1000PF, 10%, 50V, MONO CERAMIC	C-452-1000P
C6	CAP, 470U, 20%, 25V, ALUM ELEC	C-557-470
C69,C73	CAPACITOR	C-606-470
C8,C115,C156,C161,C162	CAP, .1UF, 10%, 25V, CERAMIC	C-495-.1
C86,C88-C92,C97-C99,C11, C12,C18, C23,C29	CAP, .1UF, 20%, 50V, CERAMIC	C-418-.1
CR1,CR2	DIODE, SWITCHING, MMBD914	RF-83
CR13,CR14,CR17,CR18, CR25-CR30	DIODE, DUAL SWITCHING, BAV99L	RF-82
CR15,CR16	DIODE, SCHOTTKY BARRIER, 50V, BAS86	RF-129
CR19-CR23	DIODE, DUAL COMMON ANODE, BAW56LT2	RF-98
CR24	DIODE, MBR5130LT3	RF-115
CR3,CR4,CR8-CR11	ULTRAFAST POWER RECTIFIER	RF-105
CR5,CR6	ULTRAFAST POWER RECTIFIER	RF-107

Table 6-1 (continued)

Mainframe digital board parts list

Circuit designation	Description	Keithley part no.
CR7,CR12	ULTRA FAST BRIDGE RECTIFIER, EDF1BM	RF-123
F1	POLYSWITCH, SMD030-2	FU-103
FOR CS-501	4-40X5/16 PHILLIPS PAN HD	4-40X5/16PPH
HS1,HS2,HS21-HS26	HEAT SINK	HS-55
J1003	CONN, MINI-D RIBBON, 26 PINS	CS-1105-26
J1004	CONN, CIRCULAR DIN	CS-762
J1005	CONN, D-SUB DUAL STACK M-F	CS-1072-1
J1006,J1034	LATCHING HEADER, FRICTON, SGL ROW	CS-724-3
J1007	CONN, HEADER, 36 PINS	CS-368-36
J1008	CONN, RIGHT ANGLE, 24 PIN	CS-501
J1009	CONN, HEADER, STRAIGHT SOLDER PIN	CS-368-10
J1010	CONN, DUAL, 7-PIN-BERG	CS-389-5
J1011	CONN, MALE, 4 PIN	CS-288-4
J1012	CONN, BERG	CS-339
J1033	CONN, HEADER, STRAIGHT SOLDER PIN	CS-368-16
L1,L3,L16-L18,L20,L21	FERRITE BEAD	CH-91
L2,L4-L15,L19,L22-L28,L30,L32	FERRITE CHIP, 600 OHM, BLM32A07	CH-62
L29	INDUCTOR	CH-105-1
L31	INDUCTOR	CH-89-1
L33,L34,L36-L39,L42-L44, L47-L52, L55-L57	FERRITE CHIP, 600 OHM, BLM32A07	CH-62
L35	FERRITE BEAD	CH-91
Q1,Q2	TRANS, N CHANNEL MOSFET, BUZ11	TG-211
Q3,Q5	TRANS, NPN, MMBT3904	TG-238
Q4,Q6-Q11	TRANS, N-MOSFET, VN0605T	TG-243
R1,R2,R13,R14,R34-R37,R59-R61, R68,R73	RES, 10K, 1%, 100MW, THICK FILM	R-418-10K
R111-R113	RES, 100, 1%, 100MW, THICK FILM	R-418-100
R117,R122,R146	RES, 4.75K, 1%, 100MW, THICK FILM	R-418-4.75K
R118,R119,R126-R129,R139	RES, 100, 1%, 100MW, THICK FILM	R-418-100
R120	RES, 15k, 1%, 100MW, THICK FILM	R-418-15K
R123	RES, 499, 1%, 100MW, THICK FILM	R-418-499
R125	RES, 2.21K, 1%, 100MW, THICK FILM	R-418-2.21K
R130,R132,R147	RES, 475, 1%, 100MW, THICK FILM	R-418-475

Table 6-1 (continued)
Mainframe digital board parts list

Circuit designation	Description	Keithley part no.
R131	RES, 24.3, 1%, 100MW, THICK FILM	R-418-24.3
R133,R136,R138,R163-R165,R175	RES, 1K, 1%, 100MW, THICK FILM	R-418-1K
R134	RES, 30.1K, 1%, 100MW, THICK FILM	R-418-30.1K
R135,R137	RES, 200, 1%, 100MW, THICK FILM	R-418-200
R140,R167,R169	RES, 100, 1%, 100MW, THICK FILM	R-418-100
R15,R16,R38-R40	THICK FILM SMT	TF-278-100
R152,R154,R155	RES, 475, 1%, 1/4W, METAL FILM	R-391-475
R158,R159,R160,R161	RES, 226, .1%, 1W, THICK FILM	R-418-226
R162,R166	RES, 10K, 1%, 100MW, THICK FILM	R-418-10K
R168,R170,R200,R202-R206,R219, R220,R233	RES, 10K, 1%, 100MW, THICK FILM	R-418-10K
R17,R18,R19,R20,R32	RES, 475, 1%, 1/4W, METAL FILM	R-391-475
R176-R179,R207-R210,R221-R224	RES, 909, 1%, .1W, THIN FILM	R-438-909
R180,R181,R211,R212,R225,R226	RES, 71.5, 1%, 100MW, THICK FILM	R-418-71.5
R182-R184,R213-R215,R227-R229	RES, 604, 1%, .1W, THIN FILM	R-438-604
R185,R218,R235	RES, 2K, 1%, 100MW, THICK FILM	R-418-2K
R189-R192,R195,R196	RES, 5.11K, 1%, 100MW, THICK FILM	R-418-5.11K
R216,R217,R230	RES, 715, 1%, 100MW, THIN FILM	R-438-715
R23,R26,R28	RES, 100, 1%, 1/4W, METAL FILM	R-391-100
R231,R193,R194,R197-R199,R201	RES, 49.9, 1%, 100MW, THICK FILM	R-418-49.9
R232,R236,R171-R174,R186-R188	RES, 100, 1%, 100MW, THICK FILM	R-418-100
R234,R121,R141-R145,R148-R151, R153,R157	RES, 10K, 1%, 100MW, THICK FILM	R-418-10K
R237-R242	RES, 49.9, 1%, 1/4W, METAL FILM	R-391-49.9
R24,R25,R27,R33	RES, 226, .1%, 1W, THICK FILM	R-418-226
R29,R49-R54,R56,R75-R80,R104	RES, 100, 1%, 100MW, THICK FILM	R-418-100
R3,R46,R48	RES, 2K, 1%, 100MW, THICK FILM	R-418-2K
R30	RES, 332, 10%, 1/4W, METAL FILM	R-391-332
R31	RES, 150, 1%, 100MW, THICK FILM	R-418-150
R4	RES, 332K,1%, 100MW, THICK FILM	R-418-332K
R41,R43	RES, 4.75K, 1%, 100MW, THICK FILM	R-418-4.75K
R42,R44	RES, 249,1%, 100MW, THICK FILM	R-418-249
R45,R47	RES, 221, 1%, 100MW, THICK FILM	R-418-221
R5	RES, 10M, 1%, 125MW, THICK FILM	R-418-10M
R57	RES, 33, 5%, 250mW, METAL FILM	R-376-33

Table 6-1 (continued)

Mainframe digital board parts list

Circuit designation	Description	Keithley part no.
R58	RES, 20, 1%, 100MW, THICK FILM	R-418-20
R62	RES, 100, 5%, 250MW, METAL FILM	R-376-100
R67,R87	RES, .0499, 1%, 100MW, THICK FILM	R-418-.0499
R6-R11,R55,R63-R66,R69-R72, R110	RES, 1K, 1%, 100MW, THICK FILM	R-418-1K
R74,R89-R92,R94-R103,R114	RES, 10K, 1%, 100MW, THICK FILM	R-418-10K
R81-R86,R105,R106,R115,R116	RES, 49.9, 1%, 100MW, THICK FILM	R-418-49.9
R88,R93,R107,R108,R109	RES, 10, 10%, 100MW, THICK FILM	R-418-10
SO37,SO3,SO4	SOCKET, PLCC-032-T-A	SO-143-32
T1	TRANSFORMER	TR-351A
T2	TRANSFORMER	TR-350A
TP13	SURFACE MOUNT PCB TEST POINT	CS-1026
U1	IC, HIGH SPEED PWN CONTROLLER	IC-1120
U13	IC, SERIAL EPROM 24LC16B	LSI-153
U15	IC, MICROCONTROLLER MC68332-FC	LSI-161
U16	IC, 2 INPUT EXCLUSIVE OR GATE, NC7SZ86	IC-1180
U19	IC, OCTAL INTER BUS TRANS, 75161	IC-647
U2,U17	IC, 256K X 16 BIT CMOS RAM, 17NS	LSI-249-1
U20	IC, +5V RS-232 TRANSCEIVER, MAX202	IC-952
U21,U23	IC, VOLTAGE REGULATOR, LM317T	IC-317
U22,U24	IC, VOLTAGE REGULATOR, LM337MP	IC-309
U25	IC, +5V VOLTAGE REGULATOR, LM2940CT	IC-576
U26	IC, -5V LOW DROPOUT REGULATOR	IC-1370
U27,U39,U40	LARGE SCALE IC SMT	LSI-239-1
U28,U30	IC, HEX SCHMITT INVERTER	IC-1368
U29,U41,U42	IC, 16 BIT BIDIRECTIONAL TRANSCEIV	LSI-265
U3	PROGRAMMED ROM	2520-800B01
U31,U43,U53	IC, 14 BIT MSPS A/D CONVERTOR	LSI-264
U32,U44,U56	IC, CMOS ANAL SWITCH, DG444DY	IC-866
U33,U45,U57	IC, HIGH SPEED OP AMP DUAL	IC-1429
U35	IC, PROTECTED QUAD POWER DRIVERS	IC-1212
U36	IC, STEP-DOWN VOLTAGE REGULATOR	IC-1369
U37	PROGRAMMED ROM	2520-801B01

Table 6-1 (continued)

Mainframe digital board parts list

Circuit designation	Description	Keithley part no.
U38,U49	32 BIT BUS SWITCH, HOTSWITCH	LSI-260
U4	PROGRAMMED ROM	2520-802B01
U47	LARGE SCALE IC SMT	LSI-244
U48	IC, QUAD 2 INPUT OR GATES	IC-1365
U5	IC, GPIB ADAPTER, 9914A	LSI-123
U50	IC, QUAD 2 INPUT NOR GATES	IC-1363
U51,U52	IC, HEX INVERTER	IC-1366
U54	IC, 16 BIT MULTIPLYING DAC	IC-1359
U55	IC, DUAL FET OP AMP	IC-1128
U58	IC, 8 STAGE SHIFT, C074HC409AM	IC-1026
U59	IC, HEX INVERTER	IC-1367
U6	IC, OCTAL INTERFACE BUS, 75160	IC-646
U60	IC, HIGH PRECISION 10V REFERENCE	IC-1121
U7,U9,U11,U12,U14	IC, HCPL0631, PACK	IC-1153
U8,U10,U18,U34,U46	IC, POS NAND GATES/INVERT, 74HCT14	IC-656
VR1	DIODE, ZENER 30V, BZX84C30	DZ-106-30
W1-W4	JUMPER	J-24-1
Y1	CRYSTAL, FSM327	CR-41
Y2	OSCILLATOR, 30M	CR-56-4

Table 6-2

Mainframe display board parts list

Circuit designation	Description	Keithley part no.
C901	CAP, 22UF, 20%, 6.3, TANTALUM	C-417-22
C902,C904,C907,C908,C910	CAP, .1UF, 20%,100V, CERAMIC	C-436-.1
C903,C905,C906,C909,C911	CAP, .1UF, 20%, 50V, CERAMIC	C-418-.1
C912	CAP, 2.2UF, 20%,100V, ALUM ELEC	C-503-2.2
C913,C914	CAP, 100UF, 20%, 16V, TANTALUM	C-504-100
C915,C916	CAP, 33PF, 10%, 100V, CERAMIC	C-451-33P
CR901,CR902,CR903,CR904	DIODE, SWITCHING, 250MA, BAV103	RF-89
CR905,CR906	DIODE, SWITCHING, MMBD914	RF-83
DS901	VACUUM FLUORESCENT DISPLAY	DD-51C
J1032	CONN, BERG	CS-339
J1033	CONN, HEADER, STRAIGHT SOLDER PIN	CS-368-16
Q901,Q902	TRANS, NPN GEN PURPOSE, BC868	TG-293
R901	RES NET, 15K, 2%, 1.875W	TF-219-15K
R902	RES, 13K, 5%, 125MW, METAL FILM	R-375-13K
R903,R904	RES, 4.7K, 5%, 250MW, METAL FILM	R-376-4.7K
R905	RES, 1M, 5%, 125MW, METAL FILM	R-375-1M
R906	RES, 1K, 5%, 250MW, METAL FILM	R-376-1K
R907	RES, 240, 5%, 250MW, METAL FILM	R-376-240
R908	RES, 10M, 5%, 125MW, METAL FILM	R-375-10M
T901	TRANSFORMER, TDK, ER14.5 SERIES	TR-300
U901,U904,U905	IC, LATCHED DRIVERS, UCN-5812EPF-1	IC-732
U902	PROGRAMMED ROM	7001-800A02
U903	IC, 32-BIT, SERIAL UCN5818EPF-1	IC-830
VR901	DIODE, ZENER, 8.2V, MMBZ5237	DZ-92
Y901	CRYSTAL, 4MHZ	CR-36-4M

Table 6-3
Test head board parts list

Circuit designation	Description	Keithley part no.
C1,C52,C53,C59,C60,C2	CAP, 470UF, 20%, 63V, ALUM ELEC	C-477-470
C11,C13,C17,C18,C29,C30,C33, C34,C46-C49	CAP, 22U, 20%, 25V, ALUM ELEC	C-609-22
C12,C22	CAP, 68PF, 10%, 100V, CERAMIC	C-451-68P
C15,C32	CAP, 22PF, 10%, 100V, CERAMIC	C-451-22P
C19	CAP, .1UF, 20%, 50V, CERAMIC	C-418-.1
C20,C206-C209,C210,C211, C215-C217,C27	CAP, .1UF, 20%, 50V, CERAMIC	C-418-.1
C212	CAP, .1UF, 10%, 25V, CERAMIC	C-495-.1
C23,C40	CAP, 470P, 10%, 100V, CERAMIC	C-451-470P
C231,C252	CAP, 1U, 10%, 50V, CERAMIC	C-564-1
C24,C41	CAP, 220PF, 10%, 100V, CERAMIC	C-451-220P
C25,C42	CAP, 100P, 10%, 100V, CERAMIC	C-451-100P
C254,C255	CAP, 33PF, 10%, 100V, CERAMIC	C-451-33P
C257,C259	CAP, 1UF, 20%, 50V, CERAMIC	C-237-1
C26,C43	CAP, 47PF, 10%, 100V, CERAMIC	C-451-47P
C28	CAP, .1UF, 20%, 50V, CERAMIC	C-418-.1
C3,C36,C37,C4,C44,C45,C50,C51, C56,C57	CAP, .1UF, 20%, 50V, CERAMIC	C-418-.1
C5,C54,C55,C58,C6,C61-C63, C69,C70	CAP, 22U, 20%, 25V, ALUM ELEC	C-609-22
C64,C67,C68,C7,C71,C72,C8,C256, C258	CAP, .1UF, 20%, 50V, CERAMIC	C-418-.1
C65,C66	CAPACITOR	C-606-470
C9,C10	CAP, 33U, 20%, 6.3V, TANTALUM	C-561-33
CR1,CR2,CR4,CR5	ULTRAFAST POWER RECTIFIER	RF-105
CR13,CR15,CR17,CR19,CR22	DIODE, DUAL SWITCHING, BAV99L	RF-82
CR21,CR23,CR29,CR9,CR30,C31, C14,C24	DIODE, SWITCHING, MMBD914	RF-83
CR3,CR6-CR8,CR10-CR12,CR16, CR18,CR20	DIODE, SWITCHING, MMBD914	RF-83
CR32,CR33	SCHOTTKY DIODE	RF-125
HS22	HEAT SINK	HS-55
HS3,HS20	HEAT SINK	HS-43
J1,J10	CONN, BNC	CS-547
J2,J3	TRIAx RECEPTACLE, PCB MOUNT	CS-995

Table 6-3 (continued)

Test head board parts list

Circuit designation	Description	Keithley part no.
J4	CONN, .05 MINI-D RIBBION, 26 PINS	CS-1118-1
J5	CONN, HEADER, 36 PINS	CS-368-36
J6	CONN, HEADER, STRAIGHT SOLDER PIN	CS-368-26
J8,J9	LATCHING HEADER, FRICTON, SGL ROW	CS-724-3
K1,K2,K5-K10	NON LATCHING RELAY	RL-242
K3,K4,K11,K12	RELAY	RL-185
L1,L2,L3,L4	FERRITE BEAD	CH-91
L6-L8,L11-L15,L9,L16-L18	FERRITE CHIP, 600 OHM, BLM32A07	CH-62
Q10,Q15	TRANS, NPN SILICON, 2N3904	TG-47
Q11,Q16	TRANS, PNP SILICON, 2N3906	TG-84
Q21	TRANS, N-MOSFET, VN0605T	TG-243
Q38,Q39,Q40,Q41	IC, POWER VOLT REF, LT1004CZ 2.5	IC-929
Q5,Q6	TRANS, P-CHAN, MOSFET, TP0610T	TG-259
Q7-Q9,Q12-Q14,Q17-Q19,Q28, Q36,Q37,Q20	TRANS, N-MOSFET, VN0605T	TG-243
R1,R103	RES, 121, 1%, 100MW, THICK FILM	R-418-121
R10,R12,R265,R266	RES, 15, 1%, .1W, THICK FILM	R-418-15
R100	RES, 715, 1%, 100MW, THICK FILM	R-418-715
R102,R104	RES, 402, 1%, 100MW, THICK FILM	R-418-402
R11,R7	RES, 121K, 1%,100MW, THICK FILM	R-418-121K
R14,R45	RES, 1, 1%, 100MW, THICK FILM	R-418-1
R15,R39,R46,R69	RES, .0499, 1%, 100MW, THICK FILM	R-418-.0499
R16,R47	RES, 49.9, 1%, 100MW, THICK FILM	R-418-49.9
R18,R9	RES, 200K, .1%, 1/10W, METAL FILM	R-263-200K
R2,R3,R92-R96,R101,R221, R244-R247,R90	RES, 1K, 1%, 100MW, THICK FILM	R-418-1K
R222,R223	RES, 10K, 1%, 100MW, THICK FILM	R-418-10K
R238,R239	RES, 59K, 1%, 100MW, THICK FILM	R-418-59K
R24,R250,R260,R54	RES, 200, 1%, 100MW, THICK FILM	R-418-200
R248,R249	RES, 499, 1%, 100MW, THICK FILM	R-418-499
R252-R255,R258,R259,R36, R37,R66,R67	RES, 24.3, 1%, 100MW, THICK FILM	R-418-24.3
R256,R257	RES, 24.3, 1%, 100MW, THICK FILM	R-418-24.3
R262,R263	RES, 1M, 1%, 100MW, THICK FILM	R-418-1M
R26-R35,R56-R65	RES, 249, 1%, .1W, THIN FILM	R-438-249

Table 6-3 (continued)
Test head board parts list

Circuit designation	Description	Keithley part no.
R4,R6	RES, 8.98K, .1%, .125W, THIN FILM	R-456-8.98K
R40,R41,R70,R71	RES, 1.1K, .1%, .125W, THIN FILM	R-456-1.1K
R42,R43,R72,R73,R88,R89	RES, 49.9, 1%, 1/4W, METAL FILM	R-391-49.9
R5,R8	RES, 10K, .1%, .125W, THIN FILM	R-456-10K
R76-R79	RES, 402, 1%, 125W, THIN FILM	R-456-402
R80-R83	RES, 80.6, 1%, 125W, THIN FILM	R-456-80.6
R84,R85,R86,R87	RES, 121, .1%, .125W, THIN FILM	R-456-121
R91,R224	RES, 249, 1%, 100MW, THICK FILM	R-418-249
R97,R98,R99	RES, 100, 1%, 100MW, THICK FILM	R-418-100
TP1,TP2,TP10,TP12,TP20-TP23	SURFACE MOUNT PCB TEST POINT	CS-1026
TP6,TP25-TP27	CONN, TESTPOINT	CS-985
U1,U2	IC, +5V, 12 BIT DAC	IC-1329
U10,U12,U13,U8	IC, HIGH SPEED OP AMP DUAL	IC-1429
U11	IC, POS NAND GATES/INVERT, 74HCT14	IC-656
U20,U3	IC, HIGH VOLTAGE OP-AMP	IC-1414
U21	IC, 3 TO 8 LINE DECODER	IC-1378
U22	IC, +5V VOLTAGE REGULATOR, LM2940CT	IC-576
U23	IC, -5V, LOW DROPOUT REGULATOR	IC-1370
U4,U5,U6	IC, 8 STAGE SHIFT, C074HC409AM	IC-1026
U9	IC, HCPL0631, PACK	IC-1153
	RES, 499, 1%, 1/4W, METAL FILM	R-391-499
	TRANS, CURR REG, CDLL5313	TG-321

Table 6-4

Pulse board parts list

Circuit designation	Description	Keithley part no.
C1	CAP, .1UF, 10%, 25V, CERAMIC	C-495-.1
C10,C11,C12,C13	CAP, 680U, 20%, 50V, ALUM ELEC	C-578-680
C14	CAP, 10U, 20%, 35V, TANTALUM	C-551-10
C16,C19,C22,C24,C27,C29	CAP, 22U, 20%, 25V, ALUM ELEC	C-609-22
C26,C28,C2,C31,C32,C39,C40,C44, C45,C47	CAP, .1UF, 20%, 50V, CERAMIC	C-418-.1
C3,C4,C6-C9,C15,C17,C18, C20,C21,C23,C25	CAP, .1UF, 20%, 50V, CERAMIC	C-418-.1
C33	CAP, 2200P, 1%, 50V, CERAMIC	C-532-2200P
C34	CAP, 150PF, 5%, 100V,CERAMIC	C-465-150P
C35,C36	CAP, 270PF, 5%, 100V, CERAMIC	C-465-270P
C37	CAP, 33PF, 5%, 100V, CERAMIC	C-465-33P
C38	CAP, 47P, 5%, 100V, CERAMIC	C-465-47P
C41	CAP, 470U, 20%, 25V, ALUM ELEC	C-478-470
C42	CAP, 2200P, 1%, 50V, CERAMIC	C-532-2200P
C46	CAP, .1UF, 20%, 50V, CERAMIC	C-418-.1
C5	CAP, 10PF, 5%, 50V, MONO CERAMIC	C-452-10P
CR1	SCHOTTKY DIODE	RF-121
CR2,CR3,CR4,CR5,CR6,CR7	DIODE, SWITCHING, MMBD914	RF-83
DS1,DS2	LED, GRN LGT679-C0	PL-107-1
HS11,HS12	HEAT SINK	HS-51
J1,J2	CONN, BNC RIGHT ANGLE PLASTIC	CS-506
J3	CONN, D-SUB MALE, BOARDLOCK TYPE	CS-848-9
J4	CONN, HEADER, STRAIGHT SOLDER PIN	CS-368-26
J5	LATCHING HEADER, FRICTON, SGL ROW	CS-724-3
K1,K2,K3	FORM 2A2B POLARIZED RELAY, S28B-5V	RL-207
L1,L2	FERRITE CHIP, 600 OHM, BLM32A07	CH-62
L3	FERRITE CHIP, 600 OHM, BLM32A07	CH-62
Q1	TRANS, P-CHAN, MMBFJ175	TG-311
Q10,Q11,Q12	HEXFET POWER MOSFET, N	TG-409
Q13,Q14,Q16,Q19,Q24	TRANS, CURR REG, CDLL5313	TG-321
Q18,Q21,Q22	TRANS, NPN, MMBT3904	TG-238
Q2,Q3,Q4	TRANS, N-MOSFET, VN0605T	TG-243
Q25,Q26,Q27	TRANS, PNP COMP SILICON AMP, MPS8599	TG-158

Table 6-4 (continued)
Pulse board parts list

Circuit designation	Description	Keithley part no.
Q5,Q6,Q7,Q8,Q17,Q20,Q23	TRANS, PNP, MMBT3906L	TG-244
Q9	TRANS, HEXFET POWER MOSFET	TG-304
R1	RES, 2.5, .1%, 1.5W, METAL FOIL	R-501-2.5
R10	RES, 22.1K, 1%, 100MW, THICK FILM	R-418-22.1K
R11,R9,R51	RES, 10K, 1%, 100MW, THICK FILM	R-418-10K
R12,R20	RES, 475, 1%, 100MW, THICK FILM	R-418-475
R15	RES, 24.9, 1%, 100MW, THICK FILM	R-418-24.9
R16,R21,R14	RES, 324, 1%, 100MW, THIN FILM	R-438-324
R2	RES, 215, 1%, 100MW, THICK FILM	R-418-215
R22,R13	RES, 38.3K, 1%, 100MW, THIN FILM	R-438-38.3K
R24	RES, 11.8K, 1%, 100MW, THIN FILM	R-438-11.8K
R25	RES, 43.2, 1%, 100MW, THICK FILM	R-418-43.2
R26	RES, 2K, 1%, 100MW, THICK FILM	R-418-2K
R27	RES, 24.9, 1%, 100MW, THICK FILM	R-418-24.9
R28,R30	RES, 200, 1%, 100MW, THICK FILM	R-418-200
R29,R53-R59,R63	RES, 2.2, 5%, 1W, THICK FILM	R-500-2.2
R3,R6,R7,R17-R19,R48,R67,R68	RES, 1K, 1%, 100MW, THICK FILM	R-418-1K
R33,R35	RES, 33, 5%, 250MW, METAL FILM	R-376-33
R34,R36,R32	RES, 33, 5%, 250MW, METAL FILM	R-376-33
R37,R40,R31	RES, 20, 1%, 100MW, THICK FILM	R-418-20
R38,R39,R41,R42	RESISTOR	R-509-2.2
R4	RES, 100K, 1%, 100MW, THICK FILM	R-418-100K
R43,R49	RES, 499, 1%, 100MW, THICK FILM	R-418-499
R44	RES, 2M, 1%, 100MW, THICK FILM	R-418-2M
R45	RES, 39.2K, 1%, 100MW, THICK FILM	R-418-39.2K
R46	NTC THERMISTOR	RT-24
R47	RES, 1.74K, 1%, 100MW, THICK FILM	R-418-1.74K
R5,R23	RES, 2.21K, 1%, 100MW, THIN FILM	R-438-2.21K
R50	RES, 100, 1%, 100MW, THICK FILM	R-418-100
R52	RES, 100, 1%, 100MW, THICK FILM	R-418-100
R60	RES, 1K, 1%, 100MW, THICK FILM	R-418-1K
R64,R66	RES, 49.9, 1%, 100MW, THICK FILM	R-418-49.9
R65	RES, 10K, 1%, 100MW, THICK FILM	R-418-10K
R69,R70	RES, 10M, 1%, 125MW, THICK FILM	R-418-10M
R71	RES, 3.32K, 1%, 100MW, THICK FILM	R-418-3.32K

Table 6-4 (continued)
Pulse board parts list

Circuit designation	Description	Keithley part no.
R72	RES, 332, 1%, 100MW, THICK FILM	R-418-332
R76	RES, 249, 1%, .1W, THIN FILM	R-438-249
R77-R81	RES, 100, 1%, 100MW, THIN FILM	R-438-100
R8	RES, 8.87K, 1%, .1W, THIN FILM	R-438-8.87K
R82,R83,R84	RES, 2.21, 1%, 100MW, THICK FILM	R-418-2.21
RT1	THERMISTOR, PD=7MW/DEG C, 1500V, 613.74K	RT-8
TP8,TP10	CONN, TESTPOINT	CS-985
U1,U6	IC, 12-BIT VOLTAGE OUTPUT DAC	IC-1130
U10,U2	IC, 8 STAGE SHIFT, C074HC409AM	IC-1026
U11	IC, POS VOLTAGE REG +15V, 500MA, 78M15	IC-194
U12	IC, +5V VOLTAGE REGULATOR, LM2940CT	IC-576
U13	IC, HCPL0631, PACK	IC-1153
U14,U25	IC, -5V VOLTAGE REGULATOR	IC-184
U15,U19	IC, VOLT. COMPARATOR, LM311M	IC-776
U16,U3	IC, TINYLOGIC CMOS INVERTER	IC-1282
U17	IC, +5V REFERENCE SOIC8	IC-1050
U18,U8	IC, 1000V OPAMP, LT1363CS8	IC-1279
U21	IC, VOLTAGE REFERENCE SOIC8	IC-1065
U4,U20	IC, DUAL FET OPAMP	IC-1128
U5	IC, SWITCHED INPUT OPAMP	IC-1439
U7	IC, QUAD SPST CMOS SWITCH, MAX4545CWP	IC-1285
U9	IC, DUAL D-TYPE F/F, 74HC74	IC-773

Table 6-5
Miscellaneous parts list

Qty	Description	Keithley part no.
1	AC ON/OFF LINE SWITCH	PM-6-1
1	BEZEL, REAR	428-303D
4	CABLE ASSEMBLY, BNC	CA-290-1B
1	CHASSIS	2520-301B
1	CHASSIS ASSEMBLY	2520-302B
1	CONDUCTIVE RUBBER SWITCH	2520-315A
1	CONN, FEMALE, 3 PIN, SHAPELESS	CS-287-3
2	CONN, FEMALE, 4 PIN, SHAPELESS	CS-287-4
4	CONNECTOR	CS-236
10	CONNECTOR	CS-276
6	CONNECTOR	CS-236
1	CONNECTOR, FEMALE	CS-938
1	CONNECTOR, HARDWARE KIT	CS-713
2	CONNECTOR, HOUSING	CS-638-3
1	CONNECTOR, HOUSING	CS-638-3
1	COVER	2306-307A
1	COVER TOP	2520-324A
1	COVER, BOTTOM	2520-326C
1	DISPLAY ASSEMBLY	P-2400-110D
1	DISPLAY LENS	2520-311A
2	FOOT	428-319A
1	FOOT, BLACK MOLDED POLY	FE-12
4	FOOT, BLACK MOLDED POLY	FE-10
2	FOOT, EXTRUDED	FE-22A
2	FOOT, RUBBER	FE-6
1	FRONT PANEL, MODIFIED	2520-305A
1	FUSE	FU-106-1.6
1	FUSE HOLDER	FH-39
1	HANDLE	428-329F
1	LED, BLUE	PL-112-3
1	LED, HIGH POWER, BLUE	PL-118-1
1	LED, RED/GREEN	PL-112-2
1	LENS, LED	6517-309B
1	LINE CORD	CO-7
1	MEMBRANE SWITCH, FRONT PANEL	6430-313A
1	MOUNTING EAR, LEFT	428-338B
1	MOUNTING EAR, RIGHT	428-328E
1	PCB SUPPORT	2520-329A
1	POWER SUPPLY	PS-41C
1	PRINTED FRONT PANEL	2520-306A
1	PRINTED FRONT PANEL	V-2520-306A

Table 6-5 (continued)
Miscellaneous parts list

Qty	Description	Keithley part no.
1	REAR PANEL	2520-303A
1	SAFETY COVER, MODIFIED	2520-330A
1	SWITCH	SW-513A
1	SWITCH	SW-513A
2	TRIAx CABLE	CA-289-1A

LTR.	ECA NO.	REVISION	ENG.	DATE
B		PRELIMINARY	LM/MS	9-20-00
C	25648	RELEASED	MS	11/30/00
D	25736	ADDED ADDITIONAL COMPONENTS	ELS	5/17/01

PRIMARY SIDE COMPONENTS (SIDE-08)

NOTE: FOR COMPONENT INFORMATION, SEE PRODUCT STRUCTURE.

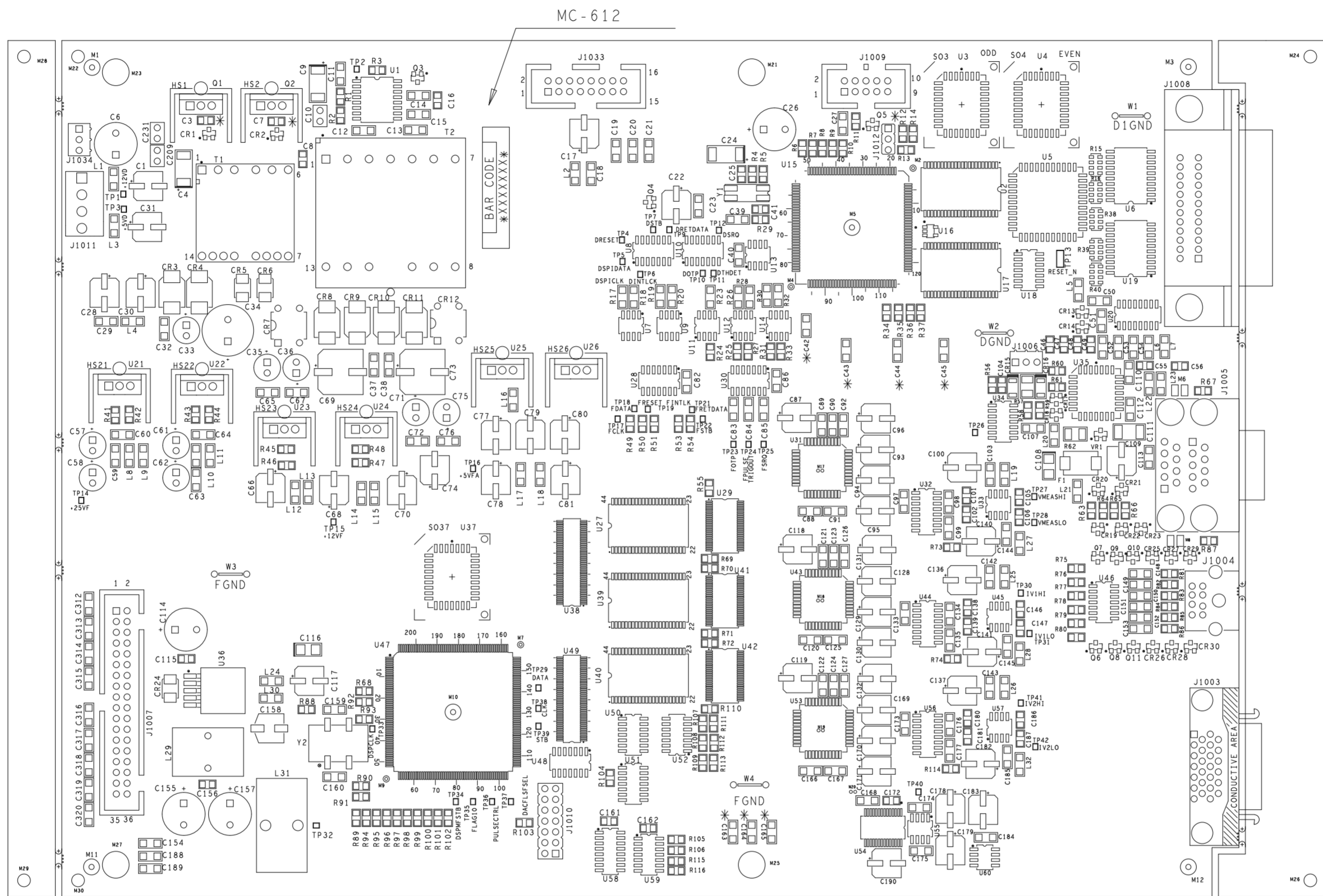

* DO NOT POPULATE *
SMT
R12, C3, C7, C42, C43, C44, C45, C163, C164, C165

MODEL	NEXT ASSEMBLY	QTY.
USED ON		

KEITHLEY KEITHLEY INSTRUMENTS INC. CLEVELAND, OHIO 44139	DIM ARE IN IN. UNLESS OTHERWISE NOTED	DATE 8-5-99	SCALE 1:1	TITLE
	DIM. TOL. UNLESS OTHERWISE SPECIFIED	DRN MS	APPR.	MAINFRAME BOARD
	XX=+.01 ANG.=+1 XXX=+.005 FRAC.=+1/64	DO NOT SCALE THIS DRAWING	C	NO.

LTR.	ECA NO.	REVISION	ENG.	DATE
B		PRELIMINARY	LM/MS	9-20-00
C	25648	RELEASED	MS	11-30-00
D	25736	ADDED ADDITIONAL COMPONENTS	ELS	5/17/01

SECONDARY SIDE COMPONENTS (SIDE-01)

NOTE: FOR COMPONENT INFORMATION, SEE PRODUCT STRUCTURE.

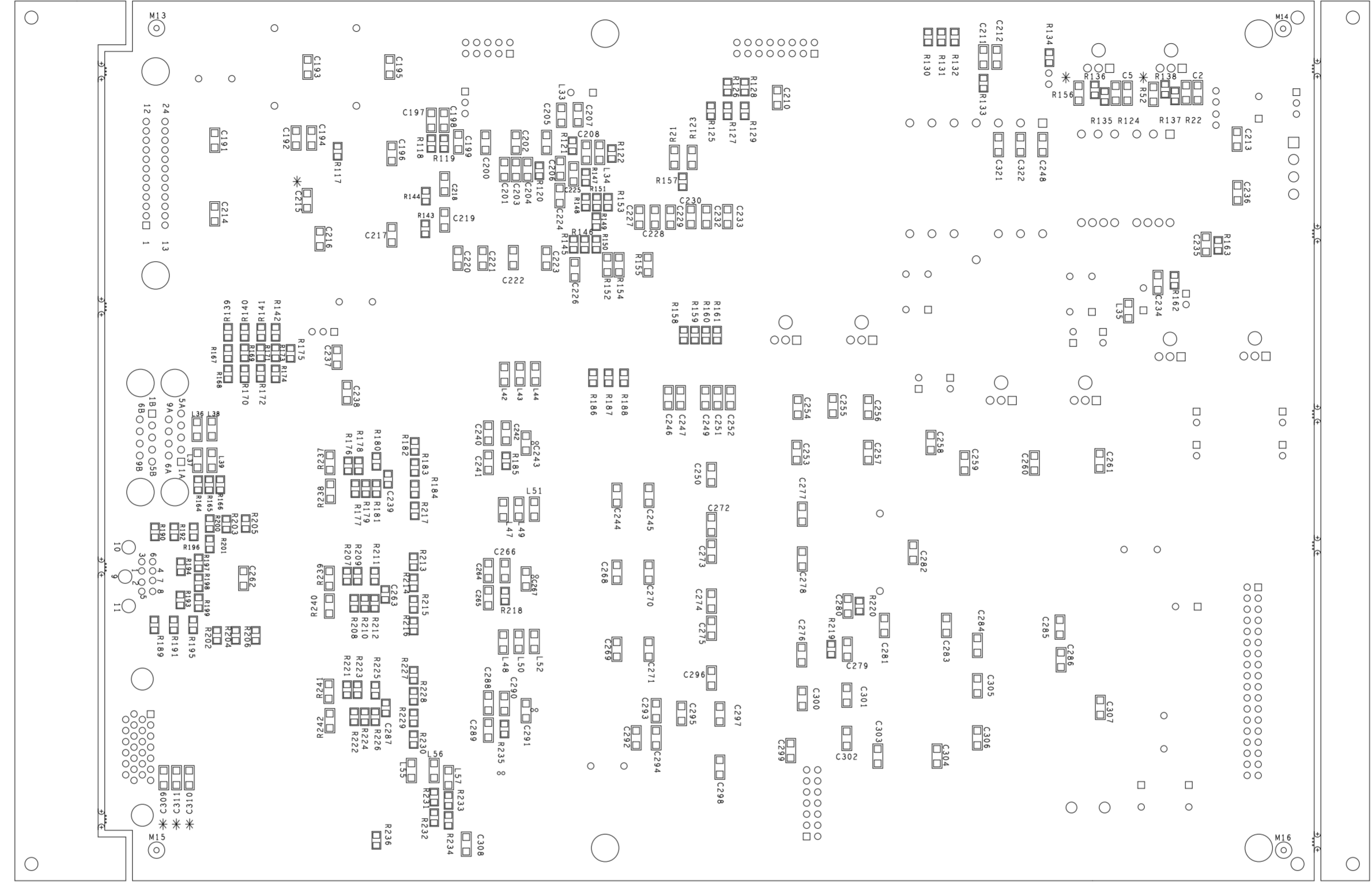

* DO NOT POPULATE *
SMT
C215, C309, C310, C311, R52, R156

MODEL	NEXT ASSEMBLY	QTY.
USED ON		

KEITHLEY KEITHLEY INSTRUMENTS INC. CLEVELAND, OHIO 44139	DIM ARE IN IN. UNLESS OTHERWISE NOTED	DATE 8-5-99	SCALE 1:1	TITLE MAINFRAME BOARD
	DIM. TOL. UNLESS OTHERWISE SPECIFIED	DRN MS	APPR.	
	XX=+.01 ANG.=+1 XXX=+.005 FRAC.=+1/64	DO NOT SCALE THIS DRAWING		C NO. 2520-100

LTR.	ECA NO.	REVISION	ENG.	DATE
C		PRELIMINARY	LM/MS	12/11/00
D	25648	RELEASED	LM/MH	3/5/01
E	25669	DELETED R25, R55, R23, R251, R53, R261 ADDED CR35, CR34, CR36, CR37	LM/MH	4/4/01
F	25901	ADDED AND REMOVED SEVERAL COMPONENTS	ELS	8/2/01

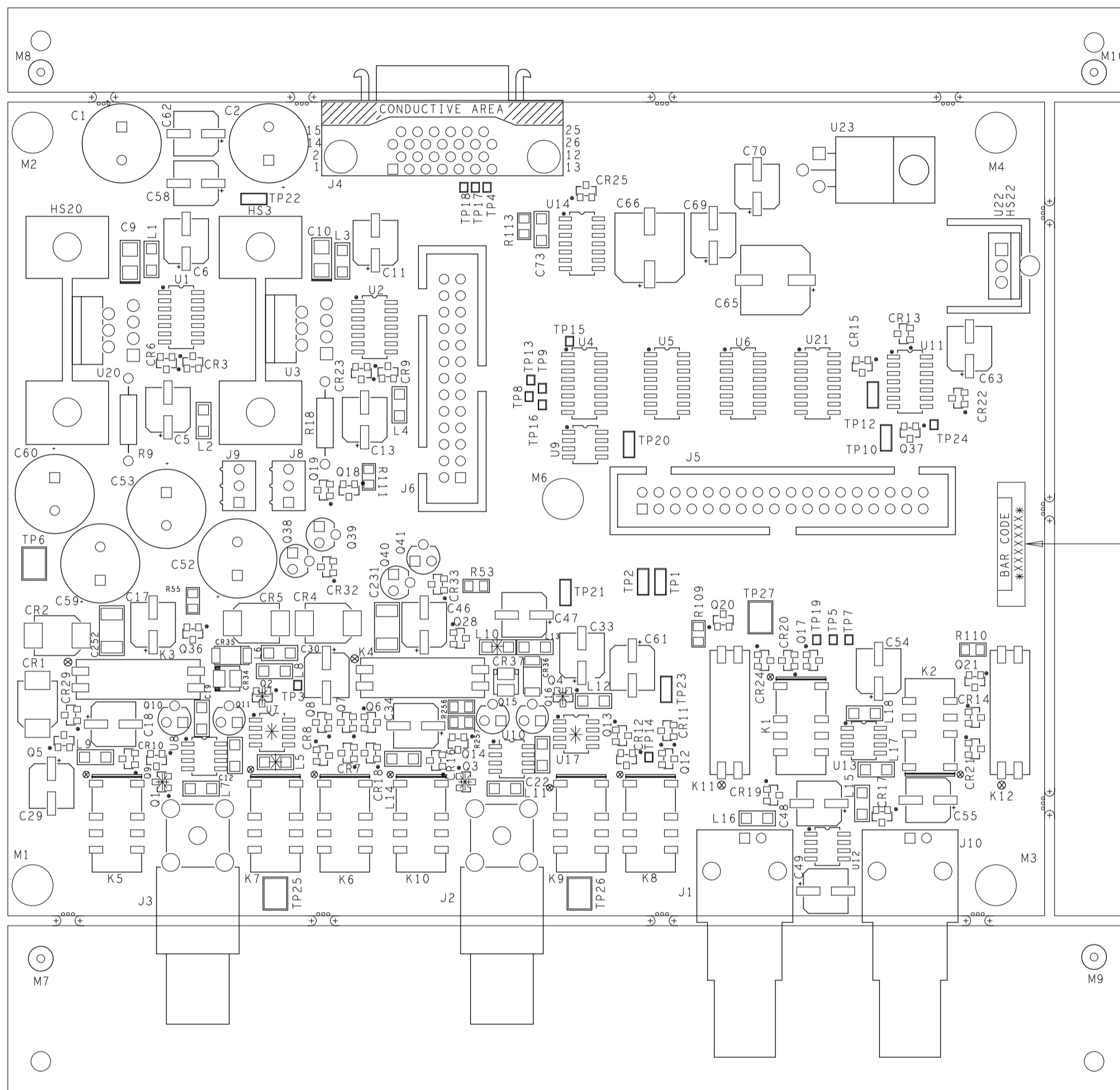

MC-612

PRIMARY SIDE COMPONENTS (SIDE-06)

NOTE: FOR COMPONENT INFORMATION, SEE PRODUCT STRUCTURE.

* DO NOT POPULATE *

SMT

L5, L10, Q1, Q2, Q3, Q4

U7, U17

MODEL	NEXT ASSEMBLY	QTY.
		USED ON

 KEITHLEY INSTRUMENTS INC. CLEVELAND, OHIO 44139	DIM ARE IN IN. UNLESS OTHERWISE NOTED	DATE 10/5/99	SCALE 3:2	TITLE
	DIM. TOL. UNLESS OTHERWISE SPECIFIED	DRN MS	APPR.	COMPONENT LAYOUT
	XX=+.01 ANG.=+1 XXX=+.005 FRAC.=+1/64	DO NOT SCALE THIS DRAWING	C	NO.

LTR.	ECA NO.	REVISION	ENG.	DATE
C		PRELIMINARY	MS/MLH	12/12/00
D	25648	RELEASED	LM/MH	3/5/01
E	25669	REVISED ARTWORK	LM/MH	4/4/01
F	25901	REVISED ARTWORK	ELS	8/2/01

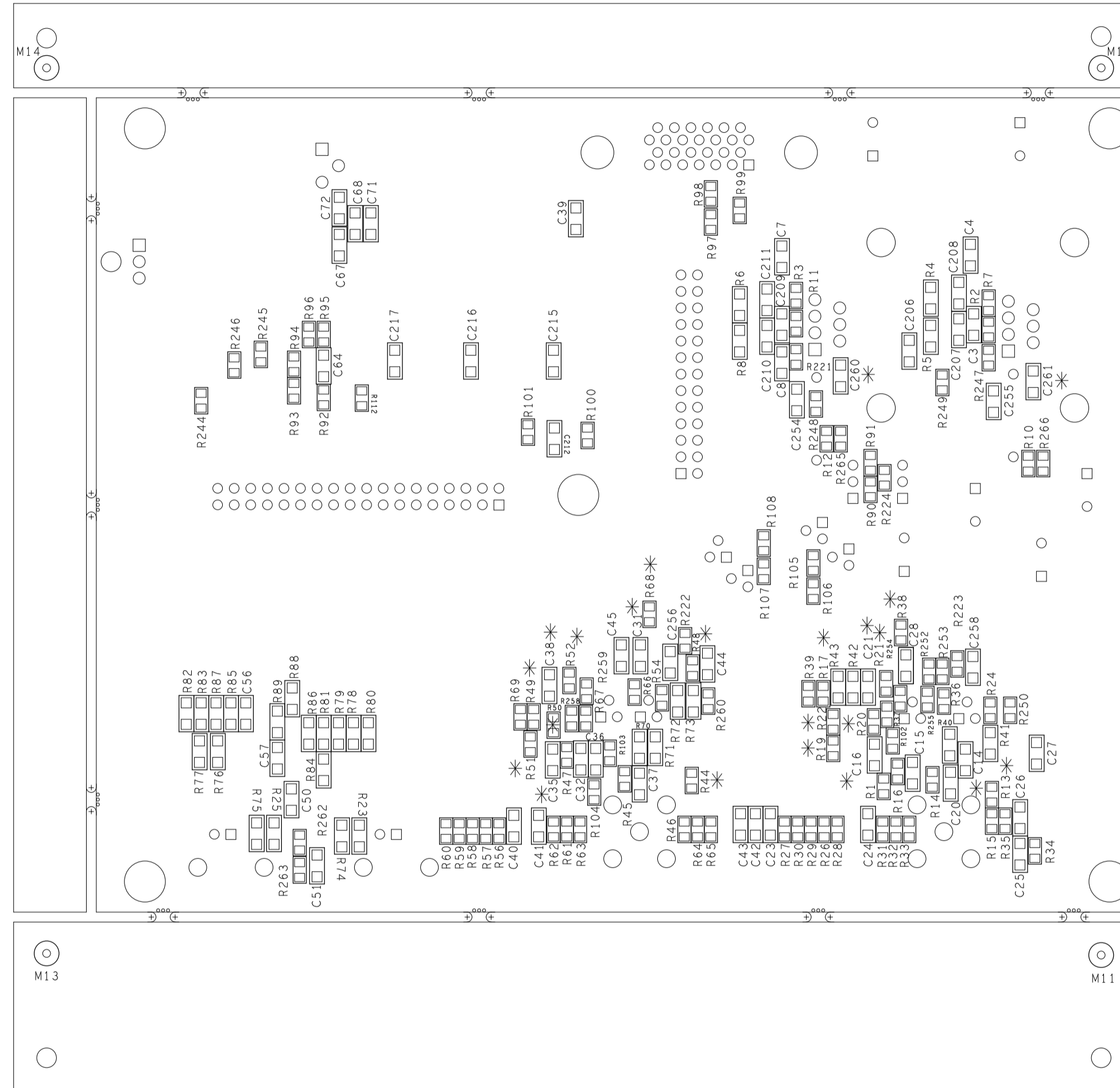

SECONDARY SIDE COMPONENTS (SIDE-01)

NOTE: FOR COMPONENT INFORMATION, SEE PRODUCT STRUCTURE.

* DO NOT POPULATE *
SMT

- R13, R17, R19, R20, R21, R22, R38
- R44, R48, R49, R50, R51, R52, R68
- C14, C16, C21, C31, C35, C38, C260, C261

MODEL	NEXT ASSEMBLY	QTY.
USED ON		

 KEITHLEY INSTRUMENTS INC. CLEVELAND, OHIO 44139	DIM ARE IN IN. UNLESS OTHERWISE NOTED	DATE 10/5/99	SCALE 3:2	TITLE
	DIM. TOL. UNLESS OTHERWISE SPECIFIED	DRN MS	APPR.	COMPONENT LAYOUT
	XX=+.01 XXX=+.005	ANG.=+1 FRAC.=+1/64	DO NOT SCALE THIS DRAWING	C NO.

2520-140

LTR.	ECA NO.	REVISION	ENG.	DATE
A		PRELIMINARY	LM/ELS	9/19/00
B		PRELIMINARY	ELS	10/25/00
C		PRELIMINARY	MS	1/15/01
D		PRELIMINARY	MS	2/20/01
E	25648	RELEASED	MS	3/01/01

PRIMARY SIDE COMPONENTS (SIDE-06)

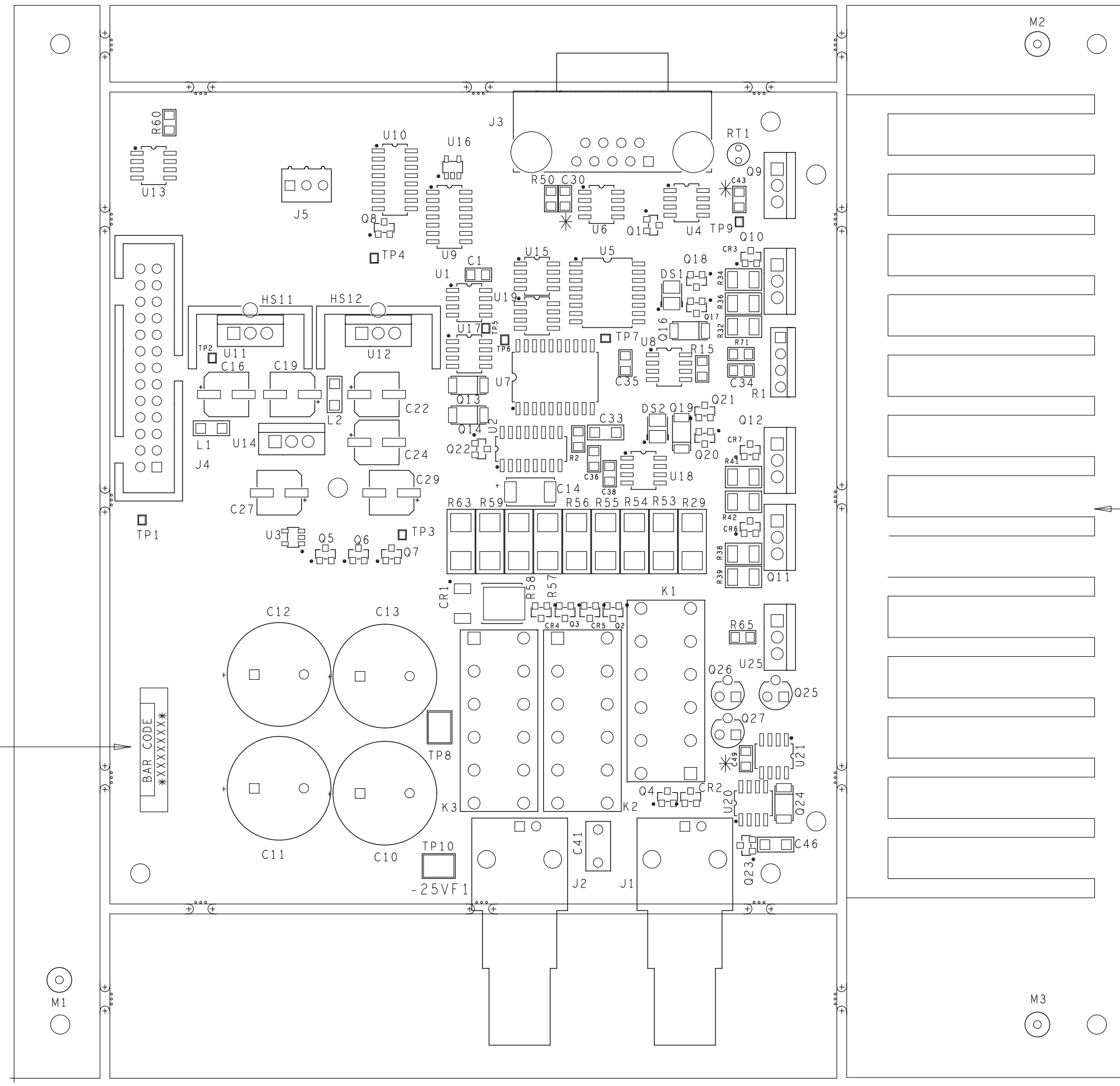

HEAT SINK 2520-328

MC-612

NOTE: FOR COMPONENT STRUCTURE, REFER TO PRODUCT STRUCTURE.

* DO NOT POPULATE *
SMT
C30, C43, C49

MODEL	NEXT ASSEMBLY	QTY.
		USED ON

KEITHLEY KEITHLEY INSTRUMENTS INC. CLEVELAND, OHIO 44139	DIM ARE IN IN. UNLESS OTHERWISE NOTED	DATE 9/15/00	SCALE 3:2	TITLE
	DIM. TOL. UNLESS OTHERWISE SPECIFIED	DRN ELS	APPR. P.S.	COMPONENT LAYOUT
XX-.01 XXX-.005	ANG.+.1 FRAC.+.1/64	DO NOT SCALE THIS DRAWING	C	No. 2520-140

2520-140

LTR.	ECA NO.	REVISION	ENG.	DATE
A		PRELIMINARY	LM/ELS	9/19/00
B		PRELIMINARY	ELS	10/25/00
C		PRELIMINARY	MS	1/15/01
D		PRELIMINARY	MS	2/20/01
E	25648	RELEASED	MS	3/01/01

SECONDARY SIDE COMPONENTS (SIDE-01)

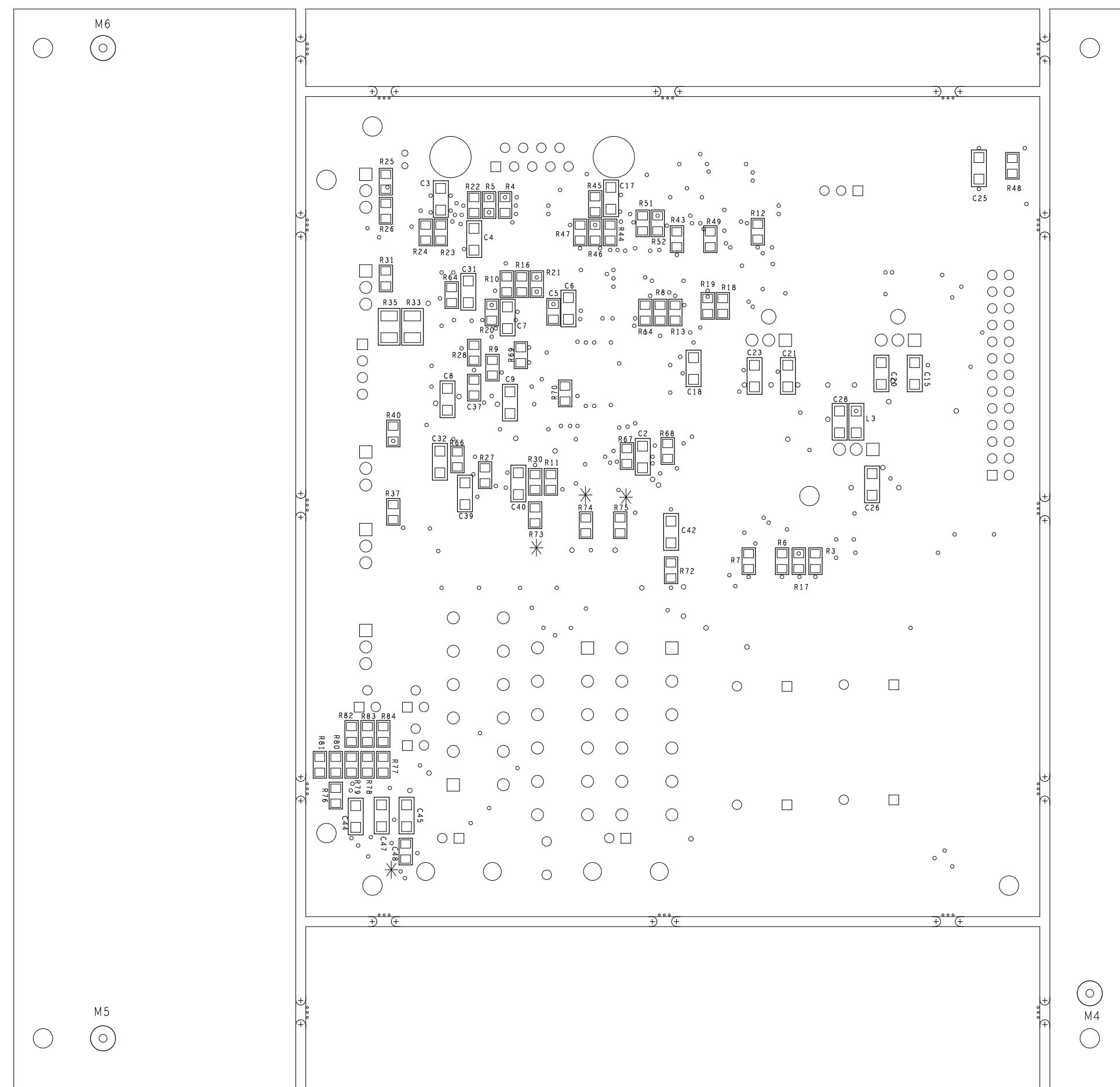

NOTE: FOR COMPONENT STRUCTURE, REFER TO PRODUCT STRUCTURE.

* DO NOT POPULATE *
R73, R74, R75, C48

MODEL	NEXT ASSEMBLY	QTY.

USED ON

KEITHLEY KEITHLEY INSTRUMENTS INC. CLEVELAND, OHIO 44139	DIM ARE IN IN. UNLESS OTHERWISE NOTED	DATE 9/15/00	SCALE 3:2	TITLE COMPONENT LAYOUT
	DIM. TOL. UNLESS OTHERWISE SPECIFIED	DRN ELS	APPR. P. S.	
XX=+.01 XXX=+.005	ANG.=+1 FRAC.=+1/64	DO NOT SCALE THIS DRAWING		C NO. 2520-140

A Specifications

LASER DIODE PULSE OR DC CURRENT SOURCE SPECIFICATIONS

DRIVE CURRENT

SOURCE RANGE	PROGRAMMING RESOLUTION	APPROX. ELECTRICAL RESOLUTION	ACCURACY ^{1,6} ±(% rdg. + mA) ^{2,3}	RMS NOISE (typical) (1kHz–20MHz) ⁵
0–500 mA	10 µA	8 µA	0.2 + 0.45	70 µA
0–1.00 A DC	100 µA	80 µA	0.2 + 4.5	800 µA
0–5.00 A Pulse				

OFF CURRENT⁴

RANGE	PROGRAMMING RESOLUTION	APPROX. ELECTRICAL RESOLUTION	ACCURACY ¹ ±(% rdg. + mA)
0–15 mA	1 µA	7 nA typ.	0.2 + 0.45
0–150 mA	10 µA	70 nA typ.	0.2 + 4.5

TEMPERATURE COEFFICIENT (0°–18°C & 28°–50°C): ±(0.15 × accuracy specification)/°C.

PULSE ON TIME: 500ns to 5ms, 100ns programming resolution.

PULSE OFF TIME: 20µs to 500ms, 10µs programming resolution; valid only in sweep mode.

PULSE DUTY CYCLE: 0 to 100% for I ≤ 1.0A; 0 to 4% for I > 1.0A.

VOLTAGE COMPLIANCE: 3V to 10V, 10mV programming resolution⁵.

POLARITY: 1 quadrant source, polarity reversal available through internal relay inversion.

OUTPUT OFF: < 200mΩ short across laser diode; measured at Remote Test Head connector.

SETTING AND RANGE	LOAD ⁷	PULSE MODE	PULSE OVERSHOOT MAX. ^{6,8,9}	RISE/FALL TIME ^{6,8,9,10} TYPICAL	MAX.
500 mA	10 Ω ¼ Watt	Fast	1.0%	55 ns	80 ns
500 mA	10 Ω ¼ Watt	Slow	0.1%	1 µs	1.3 µs
5.00 A	1.5 Ω 1 Watt	Fast	1.0%	100 ns	130 ns
5.00 A	1.5 Ω 1 Watt	Slow	0.1%	1 µs	1.3 µs

LASER DIODE VOLTAGE MEASURE SPECIFICATIONS

RANGE	MINIMUM RESOLUTION ¹⁴	ACCURACY ±(% rdg. + volts) ^{1,12}	RMS NOISE (typical) ¹³
5.000 V	0.33 mV	0.3% + 6.5 mV	60 µV
10.00 V	0.66 mV	0.3% + 8 mV	120 µV

TEMPERATURE COEFFICIENT (0°–18°C & 28°–50°C): ±(0.15 × accuracy specification)/°C.

MAX. LEAD RESISTANCE: 100Ω for rated accuracy.

INPUT IMPEDANCE: 2MΩ differential, 1MΩ from each input to common. Input bias current ±7.5µA max.

PHOTODIODE VOLTAGE BIAS SOURCE SPECIFICATIONS (each channel)

RANGE: 0 to ±20VDC.

PROGRAMMING RESOLUTION: 10mV.

ACCURACY: ±(1% + 50mV).

CURRENT: 160mA max. with V-Bias shorted to I-Measure.

RMS NOISE (1kHz to 5MHz): 1mV typical.

PHOTODIODE CURRENT MEASURE SPECIFICATIONS (each channel)

RANGE	MINIMUM RESOLUTION ⁴	DC INPUT IMPEDANCE	ACCURACY \pm (% rdg. + current) ^{1,2}	RMS NOISE (typical) ³
10.00 mA	0.7 μ A	< 10 Ω	0.3% + 20 μ A	90 nA
20.00 mA	1.4 μ A	< 6 Ω	0.3% + 65 μ A	180 nA
50.00 mA	3.4 μ A	< 3 Ω	0.3% + 90 μ A	420 nA
100.0 mA	6.8 μ A	< 2.5 Ω	0.3% + 175 μ A	840 nA

TEMPERATURE COEFFICIENT (0°–18°C & 28°–50°C): $\pm(0.15 \times \text{accuracy specification})/^{\circ}\text{C}$.

INPUT PROTECTION: The input is protected against input shorting to the associated channel's internal bias supply. The input is protected for shorts to external supplies up to 20V for up to 1 second with no damage, although calibration may be affected.

SYSTEM SPEEDS

Reading Rates (ms)^{15,16}

Number of Source Points ¹⁷	To Memory	To GPIB
1	5.3	6.8
10 ¹⁸	9.5	18
100 ¹⁸	48	120
1000 ¹⁸	431	1170

GENERAL

DC FLOATING VOLTAGE: User may float common ground up to $\pm 10\text{VDC}$ from chassis ground.

COMMON MODE ISOLATION: $> 10^6 \Omega$.

OVERRANGE: 105% of range on all measurements and voltage compliance.

SOURCE OUTPUT MODES:

- Fixed DC Level
- Fixed Pulse Level
- DC Sweep (linear, log and list)
- Pulse Sweep (linear, log and list)

PROGRAMMABILITY: IEEE-488 (SCPI-1995.0), RS-232, 5 user-definable power-up states plus factory default and *RST.

DIGITAL INTERFACE:

Safety Interlock: External mechanical contact connector and removable key switch.

Aux. Supply: +5V @ 300mA supply.

Digital I/O: 2 trigger input, 4 TTL/Relay Drive outputs (33V @ 500mA max., diode clamped).

Tlink: 6 programmable trigger input/outputs.

Pulse Trigger Out BNC: +5V, 50 Ω output impedance, output trigger corresponding to current source pulse; pulse to trigger delay < 100ns. See Figure 3.

MAINS INPUT: 100V to 240V rms, 50–60Hz, 140VA.

WARRANTY: 1 year.

EMC: Complies to European Union Directive 89/336/EEC (EN61326-1).

SAFETY: Conforms to European Union Directive 73/23/EEC EN61010-1, CAT 1.

VIBRATION: MIL-PRF-28800F Class 3, Random.

WARM-UP: 1 hour to rated accuracy.

DIMENSIONS, WEIGHT:

Main Chassis, bench configuration (with handle & feet): 105mm high \times 238mm wide \times 416mm deep (4 $\frac{1}{8}$ in \times 9 $\frac{3}{8}$ in \times 16 $\frac{3}{8}$ in). 2.67kg (5.90 lbs).

Remote Test Head: 95mm high \times 178mm deep (with interlock key installed) \times 216mm wide (3 $\frac{1}{2}$ in \times 7 in \times 8 $\frac{1}{2}$ in). 1.23kg (2.70lbs).

Cable Length, From Main Unit to Remote Test Head: 2.1m (83 in).

ENVIRONMENT:

Operating: 0°–50°C, 70% R.H. up to 35°C. Derate 3% R.H./°C, 35°–50°C.

Storage: –25° to 65°C.

Notes

¹ 1 year, 23°C ±5°C.

² If $\sqrt{\text{Duty Cycle}} \cdot I$ exceeds 0.2, accuracy specifications must be derated with an additional error term as follows:

500mA Range: $\pm 0.1\% \text{ rdg.} \cdot \sqrt{D} \cdot I \cdot K$

5A Range: $\pm 0.3\% \text{ rdg.} \cdot \sqrt{D} \cdot I \cdot K$

where: I = current setting

D = duty cycle

K = 0.5 for time < 5 minutes

1 for time > 5 minutes.

This derating must also be applied for a period equal to the time that $\sqrt{D} \cdot I$ was ≥ 0.2 .

³ Not including overshoot and settling time.

⁴ Pulse mode only.

⁵ Output: 500mA DC on 500mA range and 1A DC on 5A range.

⁶ See Figure 4 for test configuration.

⁷ Figures 1 and 2 are typical pulse outputs into resistive loads.

⁸ Typical.

⁹ Per ANSI/IEEE Std 181-1977.

¹⁰ Per ANSI/IEEE Std 181-1977 10% to 90%.

¹¹ DC accuracy $\pm 700\text{mV}$ @ output terminal. 0.2 Ω typical output impedance.

¹² At DC, 10 μs measurement pulse width, Filter off.

¹³ Standard deviation of 10,000 readings with 10 μs pulse width, filter off, with I source set to 0 amps DC.

¹⁴ The A/D converter has 14 bit resolution. The useful resolution is improved by reading averaging. The useful resolution is:

$$\text{Useful Resolution} = \frac{\text{Range}}{2^{14}} \cdot \frac{1}{\sqrt{\frac{\text{Pulse Width (ns)} - 400\text{ns}}{100\text{ns}} \cdot \text{Averaging Filter Setting}}}$$

¹⁵ Excluding total programmed (Pulse ON time + Pulse OFF time).

¹⁶ Front panel off, calc off, filter off, duty cycle < 10%, binary communications.

¹⁷ Returning 1 voltage and 2 current measurements for each source point.

¹⁸ Sweep mode.

Specifications are subject to change without notice.

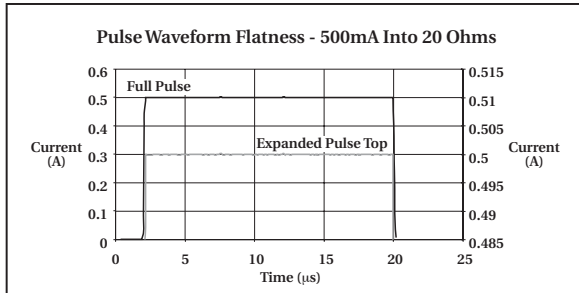

Figure 1

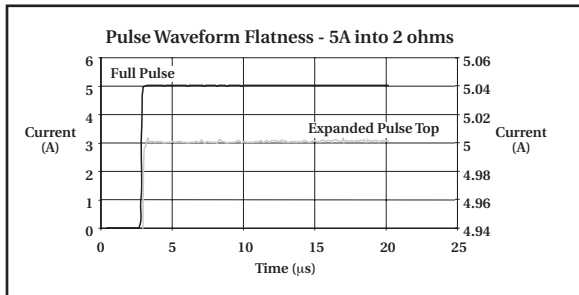

Figure 2

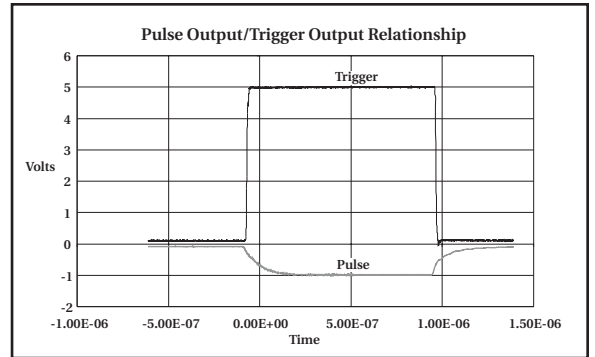

Figure 3

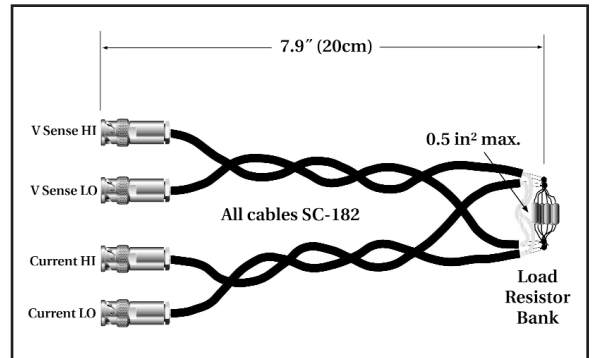

Figure 4

Accuracy calculations

The information below discusses how to calculate accuracy for both measurement and source specifications.

Measurement accuracy

Measurement accuracy specifications are stated as follows:

Accuracy = \pm (% of reading + offset)

As an example of how to calculate the actual limits, assume an input current of 10mA on the 20mA range. You can compute the limits from one-year current measurement accuracy specifications as follows:

$$\begin{aligned}\text{Accuracy} = & \pm(\% \text{ of reading} + \text{offset}) \\ & \pm[(0.3\% \times 10\text{mA}) + 65\mu\text{A}] \\ & \pm(30\mu\text{A} + 65\mu\text{A}) \\ & \pm 95\mu\text{A}\end{aligned}$$

Thus, the reading limits are: 10mA \pm 95 μ A, or from 9.905mA to 10.095mA.

Source accuracy

Source accuracy specifications are stated as follows:

Accuracy = \pm (% of setting + offset)

For example, assume a DC source current of 200mA on the 500mA range. Limits are calculated from one-year current source accuracy specifications as follows:

$$\begin{aligned}\text{Accuracy} = & \pm(\% \text{ of setting} + \text{offset}) \\ & \pm[(0.2\% \times 200\text{mA}) + 0.45\text{mA}] \\ & \pm(0.4\text{mA} + 0.45\text{mA}) \\ & \pm 0.85\text{mA}\end{aligned}$$

Thus, the actual source current range is: 200mA \pm 0.85mA, or from 199.15mA to 200.85mA.

B

Calibration Reference

Introduction

This appendix contains detailed information on the various Model 2520 remote calibration commands, calibration error messages, and methods to detect the end of each calibration step.

Section 2 of this manual covers detailed calibration procedures.

Command summary

Table B-1 summarizes Model 2520 calibration commands. These commands are covered in detail in the following paragraphs.

Table B-1

Calibration commands

Command	Description
:CALibration	Calibration subsystem.
:PROTeCted	Calibration commands protected by password.
:CODE '<password>'	Unlock calibration. (Default password: KI002520.)
:CODE?	Query calibration code/password.
:SENSe[1] <NRf>	Calibrate active voltage measurement range.
:DATA?	Query voltage measurement calibration constants.
:SENSe2 <NRf>	Calibrate active detector 1 current measurement range.
:DATA?	Query detector 1 current measurement calibration constants.
:SENSe3 <NRf>	Calibrate active detector 2 current measurement range.
:DATA?	Query detector 2 current measurement calibration constants.
:SOURce[1] <NRf>	Calibrate active current source range.
:DATA?	Query current source calibration constants.
:PROTection	Calibrate voltage compliance DAC.
:DATA?	Query voltage compliance DAC calibration constants.
:LOW	Calibrate low current output level DAC.
:DATA?	Query low current output level DAC calibration constants.
:SOURce2 <NRf>	Calibrate detector 1 voltage bias source.
:DATA?	Query detector 1 voltage bias source calibration constants.
:SOURce3 <NRf>	Calibrate detector 2 voltage bias source.
:DATA?	Query detector 2 voltage bias source calibration constants.
:DATE <yyyy>,<mm>,<dd>	Program calibration year, month, day.
:DATE?	Query calibration date.
:NDUE <yyyy>,<mm>,<dd>	Program calibration due year, month, day.
:NDUE?	Query calibration due date.
:SAVE	Save calibration data in EEPROM.
:LOCK	Lock out calibration.
:LOCK?	Query if calibration is locked. (1 = locked; 0 = unlocked).
:COUNt?	Query number of times Model 2520 has been calibrated.

Miscellaneous commands

Miscellaneous commands are those commands that perform such functions as unlocking calibration, saving calibration constants, locking out calibration, and programming date parameters.

:CODE

(:CALibration:PROTected:CODE)

Purpose	To unlock calibration enabling you to perform the calibration procedures.
Format	:cal:prot:code '<password>'
Parameter	Up to an 8-character string including letters and numbers.
Description	The :CODE command sends the password/code and enables calibration when performing these procedures via remote. The correct password must be sent to the unit before sending any other calibration command. The default remote password is KI002520.
Note	<ul style="list-style-type: none"> • The :CODE command should be sent only once before performing calibration. Do not send :CODE before each calibration step. • To change the code, first send the present code, then send the new code. • The password parameter must be enclosed in single quotes. • If you change the first two characters of the password to something other than "KI", you will not be able to unlock calibration from the front panel.
Example	:CAL:PROT:CODE 'KI002520' Send default code of KI002520.

:COUNT?

(:CALibration:PROTected:COUNT?)

Purpose	To request the number of times the Model 2520 has been calibrated.
Format	:cal:prot:count?
Response	Number of times calibrated.
Description	The :COUNT? query may be used to determine the total number of times the Model 2520 has been calibrated.
Example	:CAL:PROT:COUNT? Request calibration count.

:LOCK

(:CALibration:PROTected:LOCK)

Purpose	To lock out calibration.	
Format	:cal:prot:lock	
Query	:cal:prot:lock?	
Response	0	Calibration unlocked
	1	Calibration locked
Description	The :LOCK command allows you to lock out calibration after completing the procedure. Thus, :LOCK performs the opposite of sending the password with the :CODE command. The :LOCK? query returns calibration lock status.	
Note	To unlock calibration, send the :CODE command with the appropriate password.	
Example	:CAL:PROT:LOCK	Lock out calibration.

:SAVE

(:CALibration:PROTected:SAVE)

Purpose	To save calibration constants in EEROM after the calibration procedure.	
Format	:cal:prot:save	
Description	The :SAVE command stores internally calculated calibration constants derived during comprehensive in EEROM. EEROM is non-volatile memory, and calibration constants will be retained indefinitely once saved. Generally, :SAVE is sent after all other calibration steps (except for :LOCK).	
Note	Calibration will be only temporary unless the :SAVE command is sent to permanently store calibration constants. Calibration data will not be saved if calibration was not unlocked by sending the :CODE command or if invalid calibration data exists.	
Example	:CAL:PROT:SAVE	Save calibration constants.

:DATE

(:CALibration:PROTected:DATE)

Purpose	To program the calibration date.
Format	:cal:prot:date <yyyy>, <mm>, <dd>
Parameters	<yyyy> = 2000 to 2099 <mm> = 1 to 12 <dd> = 1 to 31
Query	:cal:prot:date?
Response	<year>, <month>, <day>
Description	The :DATE command allows you to store the calibration date in instrument EEROM for future reference. You can read back the date from the instrument by using the :DATE? query, or by using the front panel CAL menu.
Note	The year, month, and day parameters must be delimited by commas.
Example	:CAL:PROT:DATE 2001,8,20 Send cal date (8/20/2001).

:NDUE

(:CALibration:PROTected:NDUE)

Purpose	To send the next calibration due date to the instrument.
Format	:cal:prot:ndue <yyyy>, <mm>, <dd>
Parameters	<yyyy> = 2000 to 2099 <mm> = 1 to 12 <dd> = 1 to 31
Query	:cal:prot:ndue?
Response	<year>, <month>, <day>
Description	The :NDUE command allows you to store the date, when calibration is next due, in instrument memory. You can read back the next due date by using the :NDUE? query, or by using the front panel CAL menu.
Note	The next due date parameters must be delimited by commas.
Example	:CAL:PROT:NDUE 2002,8,20 Send due date (8/20/2002).

Measurement commands

:SENSe

(:CALibration:PROTected:SENSe[1])

(:CALibration:PROTected:SENSe2)

(:CALibration:PROTected:SENSe3)

Purpose	To calibrate the active voltage or current measurement range.	
Format	:cal:prot:sens1 <Cal_voltage> :cal:prot:sens2 <Cal_current> :cal:prot:sens3 <Cal_current>	
Parameters	<Cal_current> =	Within $\pm 10\%$ of positive full-range value
	<Cal_voltage> =	0 $\pm 0.1\%$ of full-range value Within $\pm 10\%$ of negative full-range value
Description	The :CAL:PROT:SENS1 command calibrates the active voltage measurement range, while the CAL:PROT:SENS2 and :CAL:PROT:SENS3 commands calibrate the active detector 1 or detector 2 current measurement range respectively. During the calibration process, each command is sent three times for each range, once each with parameters of positive full range, 0, and negative full range. The appropriate calibration voltage or current must be applied to the appropriate input terminals.	
Example	:CAL:PROT:SENS2 20e-3	Calibrate detector 1 20mA range.

:DATA

(:CALibration:PROTected:SENSe[1]:DATA?)

(:CALibration:PROTected:SENSe2:DATA?)

(:CALibration:PROTected:SENSe3:DATA?)

Purpose	To query measurement calibration constants.	
Query	:cal:prot:sens1:data? :cal:prot:sens2:data? :cal:prot:sens3:data?	
Description	The :CAL:PROT:SENS1:DATA? query requests voltage calibration constants, while the :CAL:PROT:SENS2:DATA? and :CAL:PROT:SENS3:DATA? queries request calibration current constants for detector 1 and detector 2 respectively. Returned values are in ASCII format separated by commas.	
Example	:CAL:PROT:SENS1:DATA?	Query voltage constants.

Current source commands

:SOURce[1]

(:CALibration:PROTected:SOURce[1])

Purpose	To calibrate the current source.	
Format	:cal:prot:sour1 <Resistance>	
Parameters	<Resistance> = 10 to 15 Ω (500mA range) 1.2 to 1.6 Ω (5A range)	
Description	The :CAL:PROT:SOUR1 command calibrates the current source. During the calibration process, this command is sent with the appropriate resistance connected to the testhead (see Section 2).	
Example	:CAL:PROT:SOUR1 10	Calibrate 500mA range.

:DATA?

(:CALibration:PROTected:SOURce[1]:DATA?)

Purpose	To query current source calibration constants.	
Query	:cal:prot:sour1:data?	
Description	The :CAL:PROT:SOUR1:DATA? query requests current source calibration constants. Returned constants are in ASCII format separated by commas.	
Example	:CAL:PROT:SOUR1:DATA?	Query current source constants.

:PROTection

(:CALibration:PROTected:SOURce[1]:PROTection)

(:CALibration:PROTected:SOURce[1]:PROTection:DATA?)

Purpose	To calibrate the voltage compliance DAC.	
Format	:cal:prot:sour1:prot	
Query	:cal:prot:sour1:prot:data?	
Description	The :CAL:PROT:SOUR1:PROT command calibrates the current source voltage compliance DAC. The :CAL:PROT:SOUR1:PROT:DATA? query requests voltage compliance DAC calibration constants. Returned constants are in ASCII format separated by commas.	
Example	:CAL:PROT:SOUR1:PROT	Calibrate voltage compliance DAC.

:LOW

(:CALibration:PROTected:SOURce[1]:LOW)

(:CALibration:PROTected:SOURce[1]:LOW:DATA?)

Purpose	To calibrate the low output level DAC.	
Format	:cal:prot:sour1:low	
Query	:cal:prot:sour1:low:data?	
Description	The :CAL:PROT:SOUR1:LOW command calibrates the current source low output level DAC. The :CAL:PROT:SOUR1:LOW:DATA? query requests low output level DAC calibration constants. Returned constants are in ASCII format separated by commas.	
Example	:CAL:PROT:SOUR1:LOW	Calibrate low output level DAC.

Voltage bias source commands**:SOURce**

(:CALibration:PROTected:SOURce2)

(:CALibration:PROTected:SOURce3)

Purpose	To calibrate the detector 1 or detector 2 voltage bias source.	
Format	:cal:prot:sour2 <DMM_reading> :cal:prot:sour3 <DMM_reading>	
Parameters	<DMM_reading> = +18 to +22V -0.5 to +0.5 -18 to -22V	
Description	The :CAL:PROT:SOUR2 and :CAL:PROT:SOUR3 commands calibrate the detector 1 or detector 2 voltage bias source respectively. During the calibration process, this command is sent three times, once each with parameters of approximately +20V, 0V, and -20V. The voltage parameters are determined from a DMM reading.	
Example	:CAL:PROT:SOUR2 20	Calibrate detector 1 bias source.

:DATA?

(:CALibration:PROTected:SOURce2:DATA?)

(:CALibration:PROTected:SOURce3:DATA?)

Purpose	To query detector 1 or detector 2 voltage bias calibration constants.	
Query	:cal:prot:sour2:data? :cal:prot:sour3:data?	
Description	The :CAL:PROT:SOUR2:DATA? and :CAL:PROT:SOUR3:DATA? queries request detector 1 and detector 2 calibration constants. Returned constants are in ASCII format separated by commas	
Example	:CAL:PROT:SOUR2:DATA?	Query detector 2 constants.

Detecting calibration errors

If an error occurs during any calibration step, the Model 2520 will generate an appropriate error message. Several methods to detect calibration errors are discussed below.

Reading the error queue

As with other Model 2520 errors, any calibration errors will be reported in the error queue. (You can read the error queue by using the :SYST:ERR? query.)

Error summary

Table B-2 summarizes calibration errors.

Table B-2
Calibration errors

Error number	Error message
+500	"Date of calibration not set"
+501	"Next date of calibration not set"
+502	"Calibration data invalid"
+509	"Not permitted with cal locked"
+510	"Not permitted with cal un-locked"
+520	"Source + gain data invalid"
+521	"Source + offset data invalid"
+522	"Source - gain data invalid"
+523	"Source - offset data invalid"
+524	"Source DAC Overflow"
+525	"Source DAC Underflow"

Status byte EAV (Error Available) bit

Whenever an error is available in the error queue, the EAV (Error Available) bit (bit 2) of the status byte will be set. Use the *STB? query to obtain the status byte, then test bit 2 to see if it is set. If the EAV bit is set, an error has occurred, and you can use the appropriate error query to read the error and at the same time clear the EAV bit in the status byte.

Generating an SRQ on error

To program the instrument to generate an IEEE-488 bus SRQ (Service Request) when an error occurs, send the following command: *SRE 4. This command will enable SRQ when the EAV bit is set. You can then read the status byte and error queue as outlined above to check for errors and to determine the exact nature of the error.

Detecting calibration step completion

When sending remote calibration commands, you must wait until the instrument completes the current operation before sending another command. You can use either *OPC? or *OPC to help determine when each calibration step is completed.

Using the *OPC? query

With the *OPC? (operation complete) query, the instrument will place an ASCII 1 in the output queue when it has completed each step. To determine when the OPC response is ready, do the following:

1. Repeatedly test the MAV (Message Available) bit (bit 4) in the status byte and wait until it is set. (You can request the status byte by using the *STB? query.)
2. When MAV is set, a message is available in the output queue, and you can read the output queue and test for an ASCII 1.
3. After reading the output queue, repeatedly test MAV again until it clears. At this point, the calibration step is completed.

Using the *OPC command

The *OPC (operation complete) command can also be used to detect the completion of each calibration step. In order to use *OPC to detect the end of each calibration step, do the following:

1. Enable operation complete by sending *ESE 1. This command sets the OPC (operation complete bit) in the standard event enable register, allowing operation complete status from the standard event status register to set the ESB (event summary bit) in the status byte when operation complete is detected.
2. Send the *OPC command immediately following each calibration command. For example:

```
:CAL:PROT:SOUR2 20;*OPC
```

Note that you must include the semicolon (;) to separate the two commands, and that the *OPC command must appear on the same line as the calibration command.
3. After sending a calibration command, repeatedly test the ESB (Event Summary) bit (bit 5) in the status byte until it is set. (Use *STB? to request the status byte.)
4. Once operation complete has been detected, clear OPC status using one of two methods: (1) use the *ESR? query, then read the response to clear the standard event status register, or (2) send the *CLS command to clear the status registers. Note that sending *CLS will also clear the error queue and operation complete status.

Generating an SRQ on calibration complete

An IEEE-488 bus SRQ (service request) can be used to detect operation complete instead of repeatedly polling the Model 2520. To use this method, send both *ESE 1 and *SRE 32 to the instrument, then include the *OPC command at the end of each calibration command line, as covered above. Clear the SRQ by querying the ESR (using the *ESR? query) to clear OPC status, then request the status byte with the *STB? query.

Refer to your controller's documentation for information on detecting and servicing SRQs.

Index

A

- Aborting calibration steps 2-9
- Assembly drawings 5-3

C

- Calibration 2-1
- Calibration commands B-2
- Calibration considerations 2-4
 - Calibration cycle 2-5
 - Recommended calibration equipment 2-5
 - Resistor characterization 2-5
- Calibration errors 2-9, B-9
 - Front panel error reporting 2-9
 - Remote error reporting 2-9
- Calibration menus 2-6
- Calibration Reference B-1
- Case cover removal 5-4
- Changing the password 2-8
 - by remote 2-8
 - from the front panel 2-8
- Command summary B-2
- Component layouts 6-2
- Current measurement accuracy 1-11
- Current source accuracy 1-10
- Current source commands B-7
 - :DATA? B-7
 - :LOW B-8
 - :PROTection B-7
 - :SOURce B-7

D

- Detecting calibration errors B-9
 - Error summary B-9
 - Generating an SRQ on error B-10
 - Reading the error queue B-9
 - Status byte EAV (Error Available) bit B-10
- Detecting calibration step completion B-10
 - Generating an SRQ on calibration complete B-11
 - Using the *OPC command B-11
 - Using the *OPC? query B-10
- Disassembly 5-1

E

- Environmental conditions 2-4
 - Line power 2-4
 - Temperature and relative humidity 2-4
 - Warm-up period 2-4

F

- Factory service 6-2
- Front panel calibration 2-10
- Front panel disassembly 5-5
- Front panel tests 4-3
 - CHAR SET test 4-4
 - DISPLAY PATTERNS test 4-3
 - KEYS test 4-3

H

- Handling and cleaning 5-2
 - Handling PC boards 5-2
 - Solder repairs 5-2

I

- Instrument re-assembly 5-6

L

- Line fuse replacement 3-2

M

- Measurement commands B-6
 - :DATA B-6
 - :SENSe B-6
- Miscellaneous commands B-3
 - :CODE B-3
 - :COUNT? B-3
 - :DATE B-5
 - :LOCK B-4
 - :NDUE B-5
 - :SAVE B-4
- Model 2520 rear panel 3-2
- Motherboard removal 5-4

N

- No comm link error 4-16

O

- Ordering information 6-2

P

- Parts lists 6-2
 - Mainframe digital board 6-3
 - Mainframe display board 6-9
 - Miscellaneous 6-16
 - Pulse board 6-13
 - Test head board 6-10
- Performance Verification 1-1
- Performing the verification test procedures 1-7
 - Test considerations 1-7
 - Test summary 1-7
- Power line fuse 3-3
- Power-on self-test 4-2
- Principles of operation 4-4
 - Analog circuits 4-6
 - A/D converters 4-6
 - Measurement circuits 4-6
 - Source circuits 4-8
 - Digital circuitry 4-10
 - Digital signal processor 4-10
 - Display board circuits 4-10
 - I/O circuits 4-10
 - Microcontroller 4-10
 - Overall block diagram 4-4
 - Power supply 4-9

R

- Recommended test equipment 1-5
 - Resistor characterization 1-5
- Remote calibration 2-22
 - command summary 2-22
 - procedure 2-23
- Removing power components 5-6
 - Power module removal 5-6
 - Power supply module removal 5-6
- Repair considerations 4-2
- Resetting the calibration password 2-8
- Restoring factory defaults 1-6
- Routine Maintenance 3-1

S

- Safety considerations 4-2
- Specifications A-1
- Static sensitive devices 5-3

T

- Testhead connections 1-8, 2-10
- Testhead disassembly 5-7
 - Case disassembly 5-7
 - Input board removal 5-7
 - Output board removal 5-7
- Testhead re-assembly 5-7
- Troubleshooting 4-1, 4-12
 - Analog circuitry checks 4-15
 - Digital circuitry checks 4-14
 - Display board checks 4-12
 - Power supply checks 4-13

U

- Unlocking calibration 2-7
 - by remote 2-7
 - from the front panel 2-7

V

- Verification limits 1-6
 - Example limits calculation 1-6
- Verification test requirements 1-4
 - Environmental conditions 1-4
 - Line power 1-4
 - Warm-up period 1-4
- Viewing calibration dates and calibration count 2-9
- Voltage bias source accuracy 1-13
- Voltage bias source commands B-8
 - :DATA? B-9
 - :SOURce B-8
- Voltage measurement accuracy 1-9



Service Form

Model No. _____ **Serial No.** _____ **Date** _____

Name and Telephone No. _____

Company _____

List all control settings, describe problem and check boxes that apply to problem. _____

Intermittent Analog output follows display Particular range or function bad; specify _____

IEEE failure Obvious problem on power-up Batteries and fuses are OK

Front panel operational All ranges or functions are bad Checked all cables

Display or output (check one)

Drifts Unable to zero Unstable

Overload Will not read applied input

Calibration only Certificate of calibration required Data required

(attach any additional sheets as necessary)

Show a block diagram of your measurement including all instruments connected (whether power is turned on or not). Also, describe signal source.

Where is the measurement being performed? (factory, controlled laboratory, out-of-doors, etc.) _____

What power line voltage is used? _____ Ambient temperature? _____ °F

Relative humidity? _____ Other? _____

Any additional information. (If special modifications have been made by the user, please describe.)

Be sure to include your name and phone number on this service form.

Specifications are subject to change without notice.

All Keithley trademarks and trade names are the property of Keithley Instruments, Inc. All other trademarks and trade names are the property of their respective companies.



Keithley Instruments, Inc.

BELGIUM: Keithley Instruments B.V.
CHINA: Keithley Instruments China
FRANCE: Keithley Instruments Sarl
GERMANY: Keithley Instruments GmbH
GREAT BRITAIN: Keithley Instruments Ltd.
INDIA: Keithley Instruments GmbH
ITALY: Keithley Instruments s.r.l.
KOREA: Keithley Instruments Korea
NETHERLANDS: Keithley Instruments B.V.
SWITZERLAND: Keithley Instruments SA
TAIWAN: Keithley Instruments Taiwan

28775 Aurora Road • Cleveland, Ohio 44139 • 440-248-0400 • Fax: 440-248-6168
1-888-KEITHLEY (534-8453) www.keithley.com

Bergensesteenweg 709 • B-1600 Sint-Pieters-Leeuw • 02/363 00 40 • Fax: 02/363 00 64
Yuan Chen Xin Building, Room 705 • 12 Yumin Road, Dewai, Madian • Beijing 100029 • 8610-6202-2886 • Fax: 8610-6202-2892
3, allée des Garays • 91127 Palaiseau Cédex • 01 64 53 20 20 • Fax: 01 60 11 77 26
Landsberger Strasse 65 • D-82110 Germering • 089/84 93 07-40 • Fax: 089/84 93 07-34
Unit 2 Commerce Park, Brunel Road • Theale • Reading • Berkshire RG7 4AB • 0118 929 7500 • Fax: 0118 929 7519
Flat 2B, WILLOCRISSA • 14, Rest House Crescent • Bangalore 560 001 • 91-80-509-1320/21 • Fax: 91-80-509-1322
Viale San Gimignano, 38 • 20146 Milano • 02-48 39 16 01 • Fax: 02-48 30 22 74
2FL., URI Building • 2-14 Yangjae-Dong • Seocho-Gu, Seoul 137-130 • 82-2-574-7778 • Fax: 82-2-574-7838
Postbus 559 • NL-4200 AN Gorinchem • 0183-635333 • Fax: 0183-630821
Kriesbachstrasse 4 • 8600 Dübendorf • 01-821 94 44 • Fax: 01-820 30 81
1FL., 85 Po Ai Street • Hsinchu, Taiwan, R.O.C. • 886-3-572-9077 • Fax: 886-3-572-9031