



MCA4K00 1600Gbps to 1600Gbps OSFP Active Copper Cable Product Specifications

Table of contents

Pin Descriptions	4
Specifications	10
Ordering Information	18
Document Revision History	19

Introduction

NVIDIA® MCA4K00 is a 1600Gb/s OSFP (Octal Small Formfactor Pluggable) to 1600 Gb/s OSFP Active Copper Cable which comes in RHS to RHS (Riding Heat Sink) form factor.

Using the Octal Small Formfactor Plug (OSFP) and containing eight high-speed electrical copper pairs, each operating at data rates of up to 200Gb/s.

The cable firmware supports InfiniBand, Ethernet, and NVL5, which it can automatically detect and enable depending on the protocol of the switch it attaches to. EEPROMs provide product configuration information to be read by the host. Every cable length is tuned to reduce internal signal noise and back reflections.

NVIDIA's cable solutions provide power-efficient connectivity enabling higher port bandwidth, density and configurability at a low cost and reduced power requirement in the data centers. Rigorous cable production testing ensures best out-of-the-box installation experience, performance, and durability.

RHS to RHS

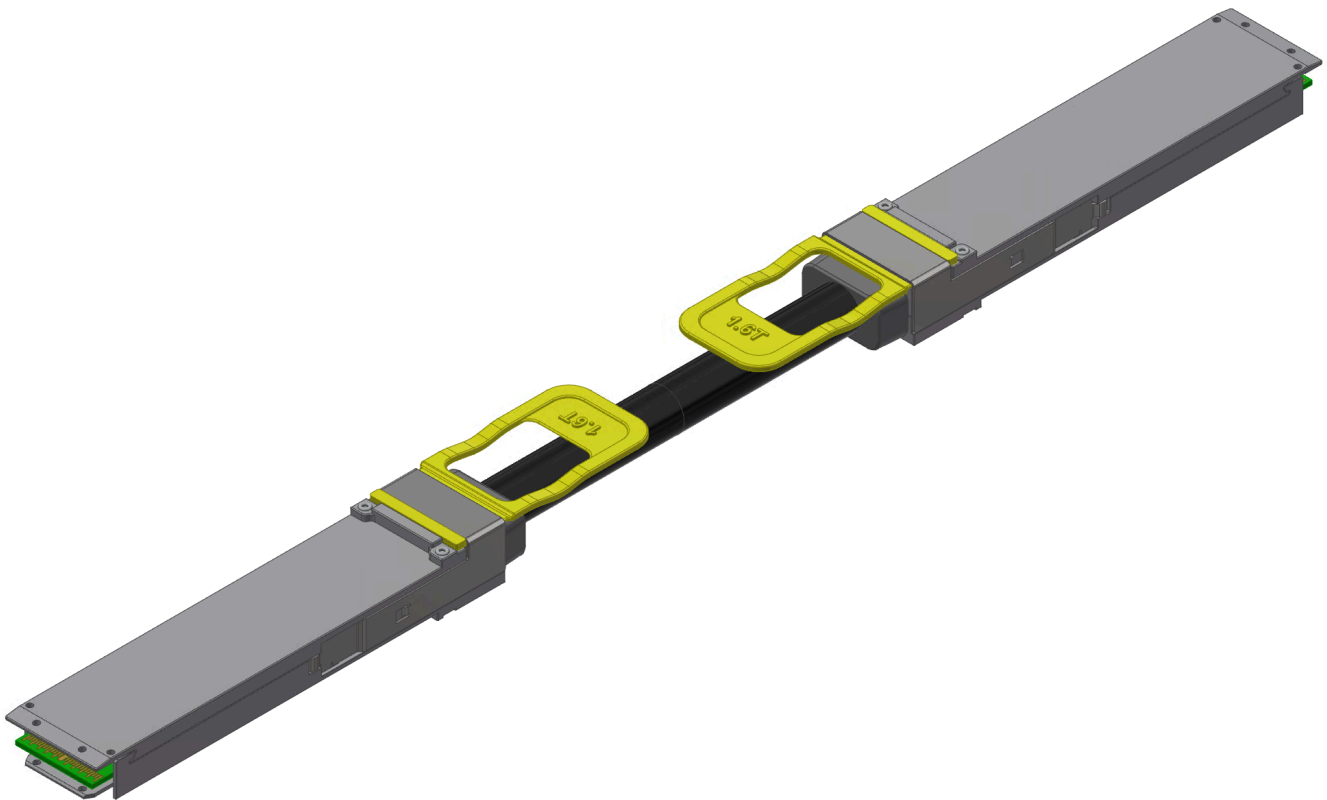

i Note

Images are for illustration purposes only. Product labels, colors, and lengths may vary.

Key Features

- 1600Gb/s data rate
- Based on 8-channels of 200G-PAM4 modulation
- SFF-8665 compliant
- Operating case temperature 0-70°C
- Single 3.3V supply voltage
- Hot pluggable
- RoHS compliant
- LSZH (Low Smoke Zero Halogen) jacket
- LF (Lead Free) HF (Halogen Free) PCB
- [OSFPxmsa.org](https://osfpmsa.org) based
- SFF-8636 compliant I²C management interface

Applications

- 1600Gb/s RHS NVL5 switch to NVL5 switch
- 800Gb/s RHS HCA to HCA

Pin Descriptions

The device is compliant with the Specification for OSFP (Octal Small Form Factor Pluggable) Modules, Rev. 1.12, see www.osfpmsa.org.

The pin assignment for the electrical (host) interface is shown below.

OSFP Pin Description

Pin	Symbol	Description	Pin	Symbol	Description
1	GND	Ground	31	GND	Ground
2	Tx2p	Transmitter Non-Inverted Data Input	32	Rx2p	Receiver Non-Inverted Data Output
3	Tx2n	Transmitter Inverted Data Input	33	Rx2n	Receiver Inverted Data Output
4	GND	Ground	34	GND	Grounds
5	Tx4p	Transmitter Non-Inverted Data Input	35	Rx4p	Receiver Non-Inverted Data Output

Pin	Symbol	Description	Pin	Symbol	Description
6	Tx4n	Transmitter Inverted Data Input	36	Rx4n	Receiver Inverted Data Output
7	GND	Ground	37	GND	Ground
8	Tx6p	Transmitter Non-Inverted Data Input	38	Rx6p	Receiver Non-Inverted Data Output
9	Tx6n	Transmitter Inverted Data Input	39	Rx6n	Receiver Inverted Data Output
10	GND	Ground	40	GND	Ground
11	Tx8p	Transmitter Non-Inverted Data Input	41	Rx8p	Receiver Non-Inverted Data Output
12	Tx8n	Transmitter Inverted Data Input	42	Rx8n	Receiver Inverted Data Output
13	GND	Ground	43	GND	Ground

Pin	Symbol	Description	Pin	Symbol	Description
14	SCL	2-wire serial interface clock	44	INT / RSTn	Module Interrupt / Module Reset
15	VCC	+3.3V Power	45	VCC	+3.3V Power
16	VCC	+3.3V Power	46	VCC	+3.3V Power
17	LPWn / PRSn	Low-Power Mode / Module Present	47	SDA	2-wire Serial interface data
18	GND	Ground	48	GND	Ground
19	Rx7n	Receiver Inverted Data Output	49	Tx7n	Transmitter Inverted Data Input
20	Rx7p	Receiver Non-Inverted Data Output	50	Tx7p	Transmitter Non-Inverted Data Input
21	GND	Ground	51	GND	Ground
22	Rx5n	Receiver	52	Tx5n	Transmitter Inverted

Pin	Symbol	Description	Pin	Symbol	Description
		Inverted Data Output			Data Input
23	Rx5p	Receiver Non-Inverted Data Output	53	Tx5p	Transmitter Non-Inverted Data Input
24	GND	Ground	54	GND	Ground
25	Rx3n	Receiver Inverted Data Output	55	Tx3n	Transmitter Inverted Data Input
26	Rx3p	Receiver Non-Inverted Data Output	56	Tx3p	Transmitter Non-Inverted Data Input
27	GND	Ground	57	GND	Ground
28	Rx1n	Receiver Inverted Data Output	58	Tx1n	Transmitter Inverted Data Input

Pin	Symbol	Description	Pin	Symbol	Description
29	Rx1p	Receiver Non-Inverted Data Output	59	Tx1p	Transmitter Non-Inverted Data Input
30	GND	Ground	60	GND	Ground

OSFP Module Pad Layout

Top Side (viewed from top)

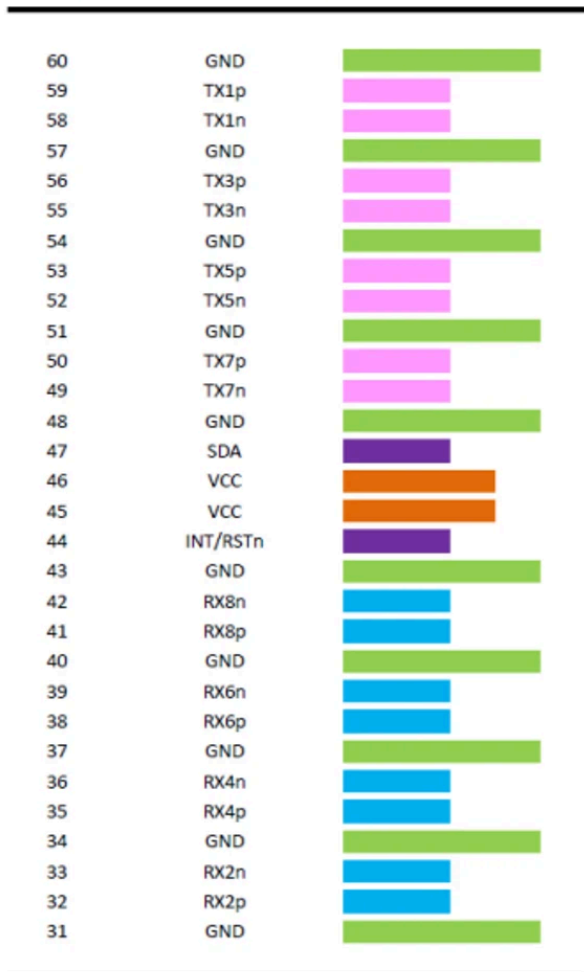

Bottom Side (viewed from bottom)

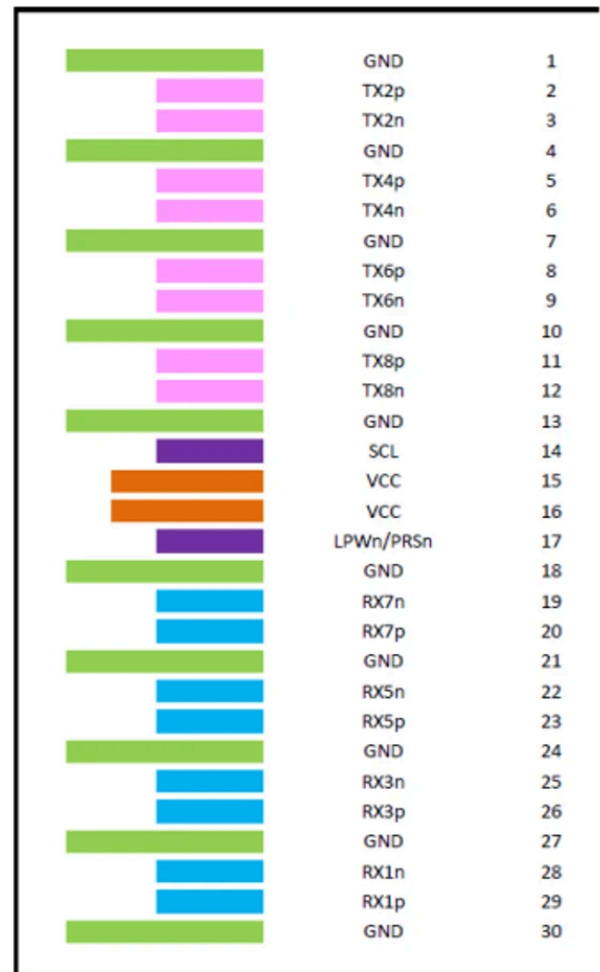

Specifications

Absolute Maximum Specifications

Absolute maximum ratings are those beyond which damage to the device may occur.

Between the operational specifications and absolute maximum ratings, prolonged operation is not intended and permanent device degradation may occur.

Parameter	Min	Max	Max
Supply Voltage	-0.3	3.6	V
Data Input Voltage	-0.3	3.6	V
Control Input Voltage	-0.3	3.6	V

Environmental Specifications

This table shows the environmental specifications for the product.

Parameter	Min	Max	Units
Storage Temperature	-40	85	°C

Operational Specifications

This section shows the range of values for normal operation.

Parameter	Min	Typ	Max	Units
Supply Voltage (Vcc)	3.135	3.3	3.465	V
Power Consumption	--	2.0	2.5	W
Operating Case Temperature	0		70	°C
Operating Relative Humidity	5		85	%

Electrical Specifications

Parameter	Min	Typ	Max	Units	Note
Characteristic impedance	90	100	110	Ω	
Time propagation delay	--	--	4.5	ns/m	Informative

Mechanical Specifications

Parameter	Value	Units
Diameter	26AWG: 10.5-11.5	mm
Length tolerance	length < 1.5 m	± 25
	length \geq 1.5 m	± 50

Minimum Bend Radius

OPN	Length (m)	AWG (mm)	Cable Diameter	Min bend radius R (mm)	Assembly Space L** Combined/Single end (mm)
980-9IAM1-00X001	1.1	26AWG, 2x8pairs	10.5-11.5	90	135
980-9IAM2-00X001	1.1	26AWG, 2x8pairs	10.5-11.5	90	135

The minimum assembly bending radius (close to the connector) is 10x the cable's outer diameter. The repeated bend (far from the connector) is also 10x the cable's outer diameter. The single bend (far from the connector) is 5x the cable's outer diameter.

**'Combined end' is the 'head' where the cables join together, inserted into the switch. 'Single end' is the 'tail' which plugs into the HCA/NIC in a server.

L = Assembly Space. Minimum value depends on the backshell (connector housing) dimensions = the space for the cable assembly behind the rack door.

Assembly Bending Radius

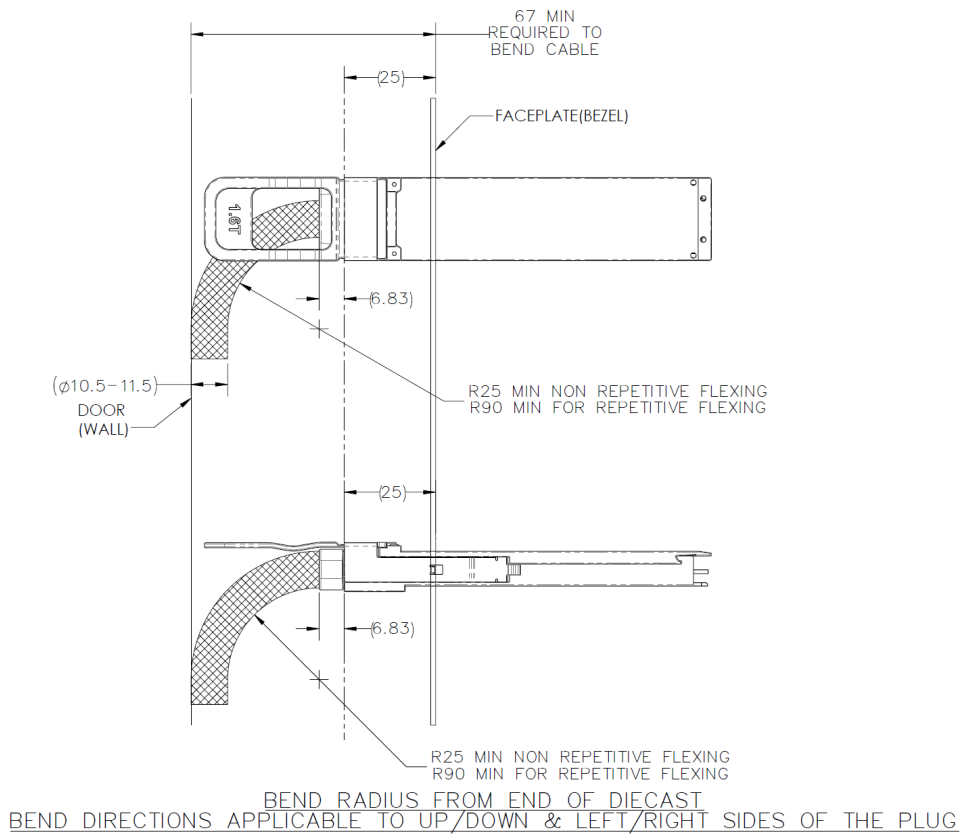

Mechanical Drawings

Option 1:

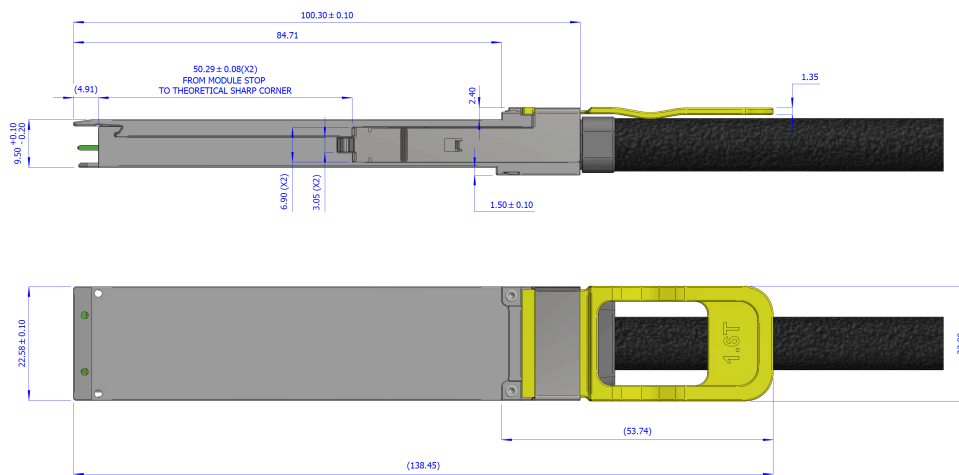

Option 2:

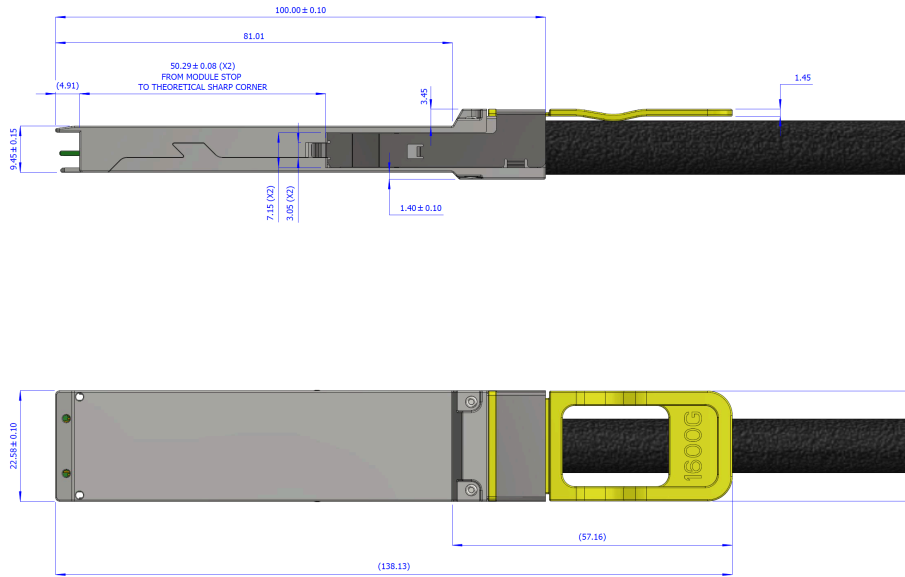

Pin Numbering

Right side:

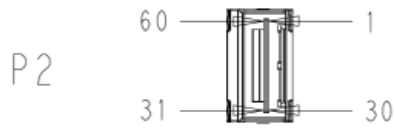

Left side:

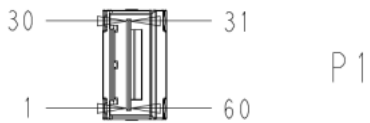

Cable Length and Labels Placement

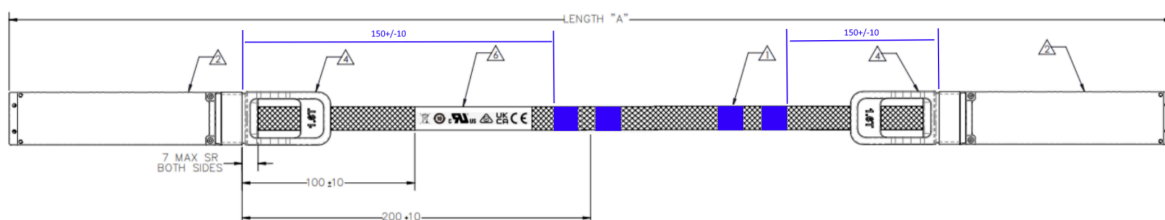

Labels

Backshell Label

The following label is applied on the cable's backshell. Note that the images are for illustration purposes only. Labels look and placement may vary.

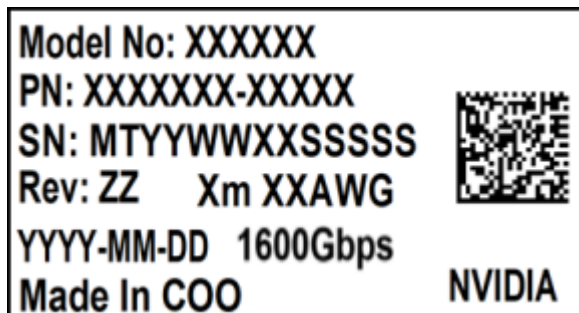

i Note

Images are for illustration purposes only. Product labels, colors, and form may vary.

Backshell Label Legend

Symbol	Meaning	Notes
PN – Part Number		
xx	Length	Meters
SN – Serial Number		
MT	Manufacturer name	2 characters
YY	Year of manufacturing	2 digits
WW	Week of manufacturing	2 digits

Symbol	Meaning	Notes
	g	
XXXXX	Serial number	5 digits for serial number. Reset at start of week to 00001.
Miscellaneous		
ZZ	HW and SW revision	2 alpha-numeric characters
Xm	Cable length	Meters
XXAWG	Cable gauge	American wire gauge
YYYY-MM-DD	Year-month-day	Year 4 digits, month 2 digits, day 2 digits
COO	Country of origin	E.g., China
	Quick response code	Serial number

Cable Jacket Label (Middle of Cable)

The following label is applied on the cable's jacket at each end. Note that the images are for illustration purposes only. Labels look and placement may vary.



i Note

The serial number and barcode are for NVIDIA internal use only. Images are for illustration purposes only. Product labels, colors, and form may vary.

Regulatory Compliance and Classification

- Safety: CB, TUV, CE, EAC, UKCA
- EMC: CE, FCC, ICES, RCM, VCCI

Ask your NVIDIA FAE for a zip file of the certifications for this product.

FCC Class A Notice

This equipment has been tested and found to comply with the limits for a Class A digital device, pursuant to part 15 of the FCC Rules. These limits are designed to provide reasonable protection against harmful interference when the equipment is operated in a commercial environment. This equipment generates, uses, and can radiate radio frequency energy and, if not installed and used in accordance with the instruction manual, may cause harmful interference to radio communications. Operation of this equipment in a residential area is likely to cause harmful interference in which case the user will be required to correct the interference at his own expense.



Cabling Information

Handling Precautions and Electrostatic Discharge (ESD)

The cable is compatible with ESD levels in typical data center operating environments and certified in accordance with the standards listed in the Regulatory Compliance Section. The product is shipped with protective caps on its connectors to protect it until the time of installation. In normal handling and operation of high-speed cables and optical transceivers, ESD is of concern during insertion into the QSFP cage of the server/switch. Hence, standard ESD handling precautions must be observed. These include use of grounded wrist/shoe straps and ESD floor wherever a cable/ transceiver is extracted/inserted. Electrostatic discharges to the exterior of the host equipment chassis after installation are subject to system level ESD requirements.

Cable Management Guidelines

It is important to follow the instructions and information detailed [NVIDIA Cable Management Guidelines](#) and [FAQ Application Note](#) to insure proper and optimal installation of this cable and avoid physical damage.

Ordering Information

Ordering Part Number	Description
980-9IAM1-00X001	NVIDIA Active copper cable, 1600Gbps to 1600Gbps, OSFP, 1.1m, RHS to RHS, standard package
980-9IAM2-00X001	NVIDIA Active copper cable, 1600Gbps to 1600Gbps, OSFP, 1.1m, RHS to RHS

Document Revision History

Revision	Date	Description
1.3	Feb. 2025	Added Cable Length and Labels Placement drawing.
1.2	Dec. 2024	Updated mechanical drawings. Public release.
1.1	Nov. 2024	Updated: <ol style="list-style-type: none">1. Introduction chapter.2. Mechanical drawings.3. Bending radius. <div data-bbox="1036 961 1463 1304" style="background-color: #ffffcc; padding: 10px;"><p>i Note Preliminary and subject to change.</p></div>
1.0	Jul. 2024	Initial release. Preliminary and subject to change.

Notice
This document is provided for information purposes only and shall not be regarded as a warranty of a certain functionality, condition, or quality of a product. NVIDIA Corporation (“NVIDIA”) makes no representations or warranties, expressed or implied, as to the accuracy or completeness of the information contained in this document and assumes no responsibility for any errors contained herein. NVIDIA shall have no liability for the consequences or use of such information or for any infringement of patents or other rights of third parties that may result from its use. This document is not a commitment to develop, release, or deliver any Material (defined below), code, or functionality. NVIDIA reserves the right to make corrections, modifications, enhancements, improvements, and any other changes to this document, at any time without notice. Customer should obtain the latest relevant information before placing orders and should verify that such information is current and complete. NVIDIA products are sold subject to the NVIDIA standard terms and conditions of sale supplied at the time of order acknowledgement, unless otherwise agreed in an individual sales agreement signed by authorized representatives of NVIDIA and customer (“Terms of Sale”). NVIDIA hereby expressly objects to applying any customer general terms and conditions with regards to the purchase of the NVIDIA product referenced in this document. No contractual obligations are formed either directly or indirectly by this document. NVIDIA products are not designed, authorized, or

warranted to be suitable for use in medical, military, aircraft, space, or life support equipment, nor in applications where failure or malfunction of the NVIDIA product can reasonably be expected to result in personal injury, death, or property or environmental damage. NVIDIA accepts no liability for inclusion and/or use of NVIDIA products in such equipment or applications and therefore such inclusion and/or use is at customer's own risk.

NVIDIA makes no representation or warranty that products based on this document will be suitable for any specified use. Testing of all parameters of each product is not necessarily performed by NVIDIA. It is customer's sole responsibility to evaluate and determine the applicability of any information contained in this document, ensure the product is suitable and fit for the application planned by customer, and perform the necessary testing for the application in order to avoid a default of the application or the product. Weaknesses in customer's product designs may affect the quality and reliability of the NVIDIA product and may result in additional or different conditions and/or requirements beyond those contained in this document. NVIDIA accepts no liability related to any default, damage, costs, or problem which may be based on or attributable to: (i) the use of the NVIDIA product in any manner that is contrary to this document or (ii) customer product designs.

No license, either expressed or implied, is granted under any NVIDIA patent right, copyright, or other NVIDIA intellectual property right under this document. Information published by NVIDIA regarding third-party products or services does not constitute a license from NVIDIA to use such products or services or a warranty or endorsement thereof. Use of such information may require a license from a third party under the patents or other intellectual property rights of the third party, or a license from NVIDIA under the patents or other intellectual property rights of NVIDIA.

Reproduction of information in this document is permissible only if approved in advance by NVIDIA in writing, reproduced without alteration and in full compliance with all applicable export laws and regulations, and accompanied by all associated conditions, limitations, and notices.

THIS DOCUMENT AND ALL NVIDIA DESIGN SPECIFICATIONS, REFERENCE BOARDS, FILES, DRAWINGS, DIAGNOSTICS, LISTS, AND OTHER DOCUMENTS (TOGETHER AND SEPARATELY, "MATERIALS") ARE BEING PROVIDED "AS IS." NVIDIA MAKES NO WARRANTIES, EXPRESSED, IMPLIED, STATUTORY, OR OTHERWISE WITH RESPECT TO THE MATERIALS, AND EXPRESSLY DISCLAIMS ALL IMPLIED WARRANTIES OF NONINFRINGEMENT, MERCHANTABILITY, AND FITNESS FOR A PARTICULAR PURPOSE. TO THE EXTENT NOT PROHIBITED BY LAW, IN NO EVENT WILL NVIDIA BE LIABLE FOR ANY DAMAGES, INCLUDING WITHOUT LIMITATION ANY DIRECT, INDIRECT, SPECIAL, INCIDENTAL, PUNITIVE, OR CONSEQUENTIAL DAMAGES, HOWEVER CAUSED AND REGARDLESS OF THE THEORY OF LIABILITY, ARISING OUT OF ANY USE OF THIS DOCUMENT, EVEN IF NVIDIA HAS BEEN ADVISED OF THE POSSIBILITY OF SUCH DAMAGES. Notwithstanding any damages that customer might incur for any reason whatsoever, NVIDIA's aggregate and cumulative liability towards customer for the products described herein shall be limited in accordance with the Terms of Sale for the product.

Trademarks

NVIDIA and the NVIDIA logo are trademarks and/or registered trademarks of NVIDIA Corporation in the U.S. and other countries. Other company and product names may be trademarks of the respective companies with which they are associated.

© Copyright 2025, NVIDIA. PDF Generated on 02/20/2025