

# TriBoard Manual TC3X7 ADAS

**Hardware: TriBoard TC3X7 ADAS TH V2.0 and TriBoard TC3X7 ADAS V2.0**

## About this document

### Scope and purpose

The User Manual provide information about using, configuration and connecting the TriBoard with Infineon AURIX™ TC3X7 ADAS device. The manual provide information for different hardware types. There exist different hardware with Through Hole socket (TriBoard TC3X7 ADAS TH) and soldered devices (TriBoard TC3X7 ADAS). The schematic is identically for the all boards if not other mentioned in chapter schematic. The placing on the boards is slightly different around the TC3X7 ADAS itself dependent of the space (socket need more space and has through hole), but the most components are on the same location. All figures are valid for each board if not differently mentioned.

### Intended audience

Design, verification, test and software engineers will use this document to get an understanding of the functionality and connections of the TriBoard.

Table of Contents

Table of Contents

	<b>About this document</b> .....	<b>Preface-1</b>
	<b>Table of Contents</b> .....	<b>TOC-2</b>
<b>1</b>	<b>Introduction</b> .....	<b>1-1</b>
<b>2</b>	<b>Features</b> .....	<b>2-1</b>
2.1	Summary of Features .....	2-1
2.2	Block Diagram .....	2-2
2.3	Placement .....	2-3
<b>3</b>	<b>TriBoard Information</b> .....	<b>3-1</b>
3.1	Soldered board .....	3-1
3.2	Socketed board .....	3-1
3.2.1	Usable devices .....	3-1
3.2.2	Restricted usable devices .....	3-1
3.3	Power Supply .....	3-4
3.3.1	Failsafe handling .....	3-4
3.4	LEDs .....	3-6
3.5	MMIC / RIF .....	3-6
3.5.1	Measurement RIF signals .....	3-6
3.6	Clock .....	3-7
3.7	USB Connector .....	3-7
3.7.1	Serial Connection to PC .....	3-7
3.7.2	miniWiggler JDS .....	3-8
3.8	FlexRay™ (E-RAY) .....	3-8
3.9	Serial Eeprom .....	3-9
3.10	MultiCAN .....	3-9
3.11	LIN .....	3-9
3.12	Ethernet .....	3-10
3.13	HSCT (optional) .....	3-10
3.13.1	High speed with HSCT .....	3-11
3.14	ADC .....	3-11
3.15	Other peripherals .....	3-13
3.16	Toggle LED's .....	3-13
3.17	Buttons .....	3-13
3.18	Debug System .....	3-13
3.18.1	OCDS1 .....	3-13
3.18.2	DAP .....	3-13
3.18.3	DAPE (only Emulation Device) .....	3-13
3.18.4	DAP_SCR .....	3-14
3.19	High speed with DAP/DAPE .....	3-14
3.19.1	AGBT (optional) .....	3-15
3.19.2	ETK connector (optional) .....	3-15
3.19.3	EmW Power (optional) .....	3-16
<b>4</b>	<b>TriBoard Configuration</b> .....	<b>4-1</b>
4.1	HW Boot Configuration .....	4-1
4.1.1	Default Pad State .....	4-1
4.1.2	Bootmode .....	4-1
4.2	Assembly Options .....	4-2

**Table of Contents**

4.2.1	General optional resistors .....	4-2
4.2.2	Resistors for peripherals .....	4-4
4.2.3	Resistors for MMIC .....	4-6
<b>5</b>	<b>Signal (on board used) Description .....</b>	<b>5-1</b>
5.1	Power Signals .....	5-1
5.2	Reset Signals .....	5-1
5.3	Config Signals .....	5-2
5.4	Clock Signals .....	5-2
5.5	Debug Signals .....	5-2
5.6	Peripheral Signals .....	5-3
5.7	MMIC / RIF Signals .....	5-4
<b>6</b>	<b>Connector Pin Assignment .....</b>	<b>6-1</b>
6.1	On Board only used signals .....	6-1
6.2	TC397 ADAS Connector / Top View .....	6-2
6.3	TC357/TC3A7 Connector / Top View .....	6-4
6.4	TC337 ADAS Connector / Top View .....	6-6
6.5	Power connector pinout .....	6-8
6.6	USB connector pinout .....	6-8
6.7	FlexRay™ (ERAY) connector pinout .....	6-8
6.8	CAN connector pinout .....	6-8
6.9	LIN connector pinout .....	6-9
6.10	HSCT connector pinout .....	6-9
6.11	Ethernet connector pinout .....	6-9
6.12	MMIC / RIF connector pinout .....	6-10
6.13	OCDS1 connector pinout .....	6-10
6.14	DAP connector pinout .....	6-10
6.15	ETK connector pinout .....	6-11
6.16	Ethernet miniWiggler power connector pinout .....	6-11
6.17	AGBT connector pinout .....	6-12
<b>7</b>	<b>Schematic and Layout .....</b>	<b>7-1</b>
7.1	Known problems .....	7-1
7.1.1	Known problems (TriBoard TC3X7 ADAS TH V2.0) .....	7-1
7.1.2	Known problems (TriBoard TC3X7 ADAS V2.0) .....	7-1
7.2	Schematic .....	7-1
7.2.1	Hint about used TLF30682 .....	7-1
7.3	Layout .....	7-10
7.4	Layout with Dimensioning .....	7-12

### Introduction

## 1 Introduction

We congratulate you on your purchase of the TriCore Evaluation Board. This kit is a versatile tool, providing quick access to the capabilities of TriCore's powerful architecture.

Applications can be developed easily. The Evaluation Board is equipped with a variety of memories and peripherals for connection to the environment. There is also an interface for the On Chip Debugging Features (OCDS1 and DAP).

The Evaluation Board allows easily the development of TriCore applications with the corresponding tools.

Subsequently, the applications can be downloaded and can be tested with the powerful debugger software.

This TriBoard Hardware Manual familiarizes you with the TriCore Evaluation Board and guides you through the initial configuration of the TriBoard.

For detailed technical information about the TC3X7 ADAS (e.g. TC397 ADAS, TC357, TC337 ADAS, TC3A7) please refer to the User Manual of the used device.

## Features

## 2 Features

### 2.1 Summary of Features

- Infineon’s TC3X7 ADAS (TC397 ADAS, TC357, TC337 ADAS, TC3A7)<sup>1)</sup> AURIX™ 2G Controller in LFBGA-292\_ADAS Package
- FlexRay™<sup>2)</sup> Transceivers
- High Speed CAN Transceivers (CAN-FD capable)
- USB to UART bridge
- Ethernet Gigabit PHY
- Serial Eeprom
- LIN Transceiver
- Crystal 20MHz (default) or External Clock
- USB miniWiggler JDS for easy debugging
- 8 Low Power Status LEDs
- 8-DIP switches for configuration
- access to all pins of controller
- 100mm x 160mm (EURO-Board)

### Connectors

The TC3X7 ADAS TriBoard offers a wide variety of connectors:

- Standard power connector
- Micro USB connector for ASC Interface (ASC0) and miniWiggler
- RJ45 connector for Ethernet
- 16-pin header for JTAG interface (OCDS)
- 3 x 10-pin header for DAP, DAPE and DAP\_SCR (DAPE only usable on Emulation Device)
- 10pin (2x5) Header for LIN Transceiver (LIN)
- 2 x 10pin (2x5) Header for CAN High Speed Transceiver (CAN0 and CAN1)
- 2 x 10pin (2x5) Header for FlexRay™ (ERAY-A and ERAY-B)
- 2 x 60pin (2x30) high speed connector for MMIC/RIF
- four 80-pin connectors (male) + four 80-pin connectors (female) with all I/O signals
- optional ETK connector
- optional 6pin (IEEE1394) Socket for HSCT
- optional Aurora connector (only with Emulation Device)

### Components

- Infineon’s Multi Voltage System Supply TLF30682QVS01
- Three LEDs to validate power supply (5Volt / 3,3 Volt / 1,25 Volt)
- LED indicating /HDRST (ESR0) active state
- LED indicating activ miniWiggler JDS
- LED switched via DAS software
- 2 x Infineon’s FlexRay™ Transceiver TLE9221SX
- 2 x Infineon’s High Speed CAN-Transceiver TLE9251VSJ
- Infineon’s LIN-Transceiver TLE 7259-3GE
- USB to UART bridge FT2232HL (FTDI)

1) Please see [Chapter 3.2.1](#) for usable and [Chapter 3.2.2](#) for restrict usable devices in the socketed board.

2) FlexRay™ is a trademark of FlexRay Consortium.

Features

- Integrated 10/100/1000M Ethernet Precision Transceiver RTL8211FI-CG (Realtek)
- 8 general purpose LEDs
- 2K I<sup>2</sup>C Serial Eeprom with EUI-48™<sup>1)</sup> Node Identity (MICROCHIP)
- Reset switch
- Wakeup switch
- Generic switch
- 4-pin Dip switch

Zero Ohm Bridges

Zero Ohm resistors give the flexibility to configure the systems functionality.

2.2 Block Diagram

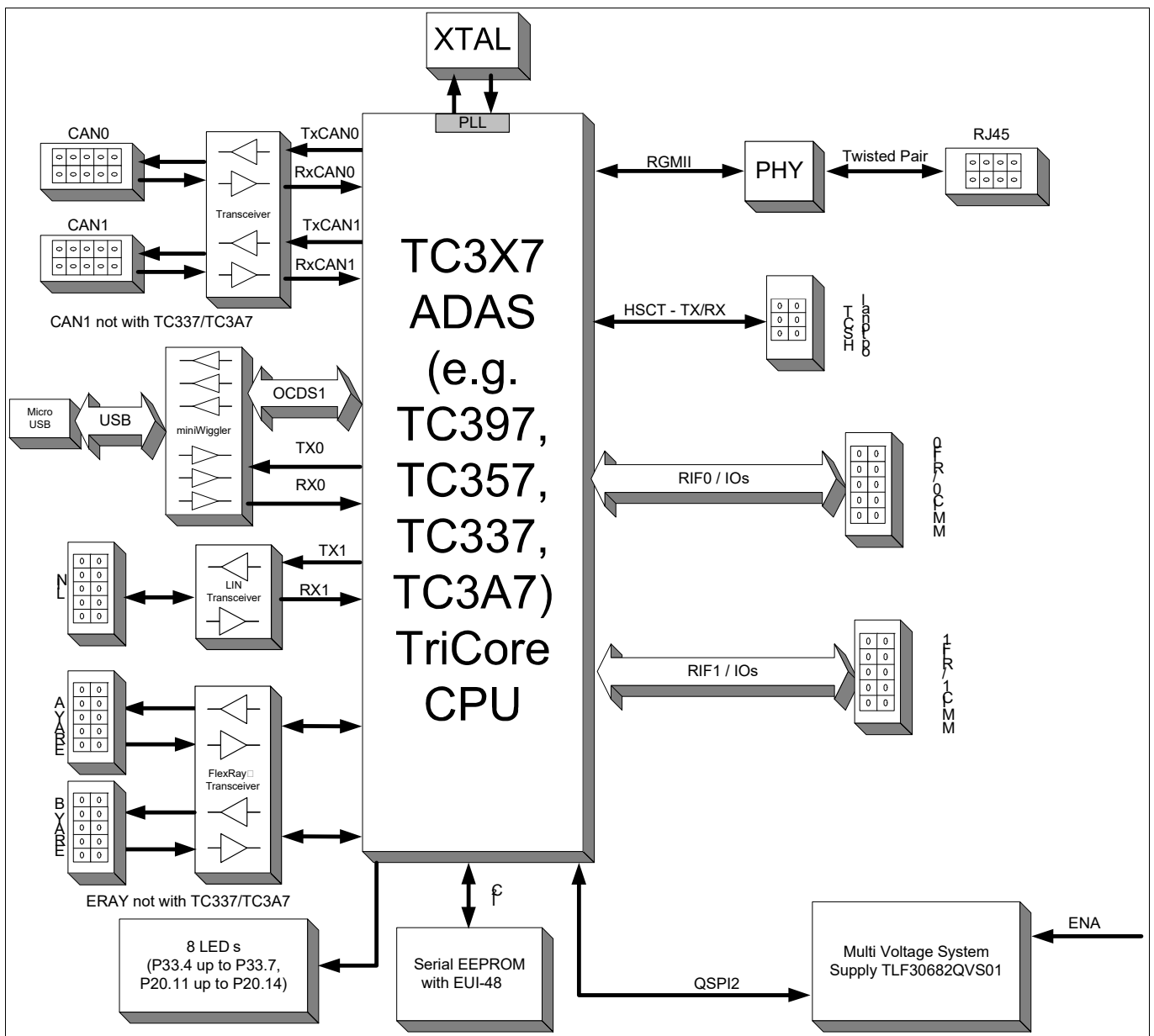

Figure 2-1 TriBoard Block Schematic

1) EUI-48™ is trademarked by IEEE

Features

2.3 Placement

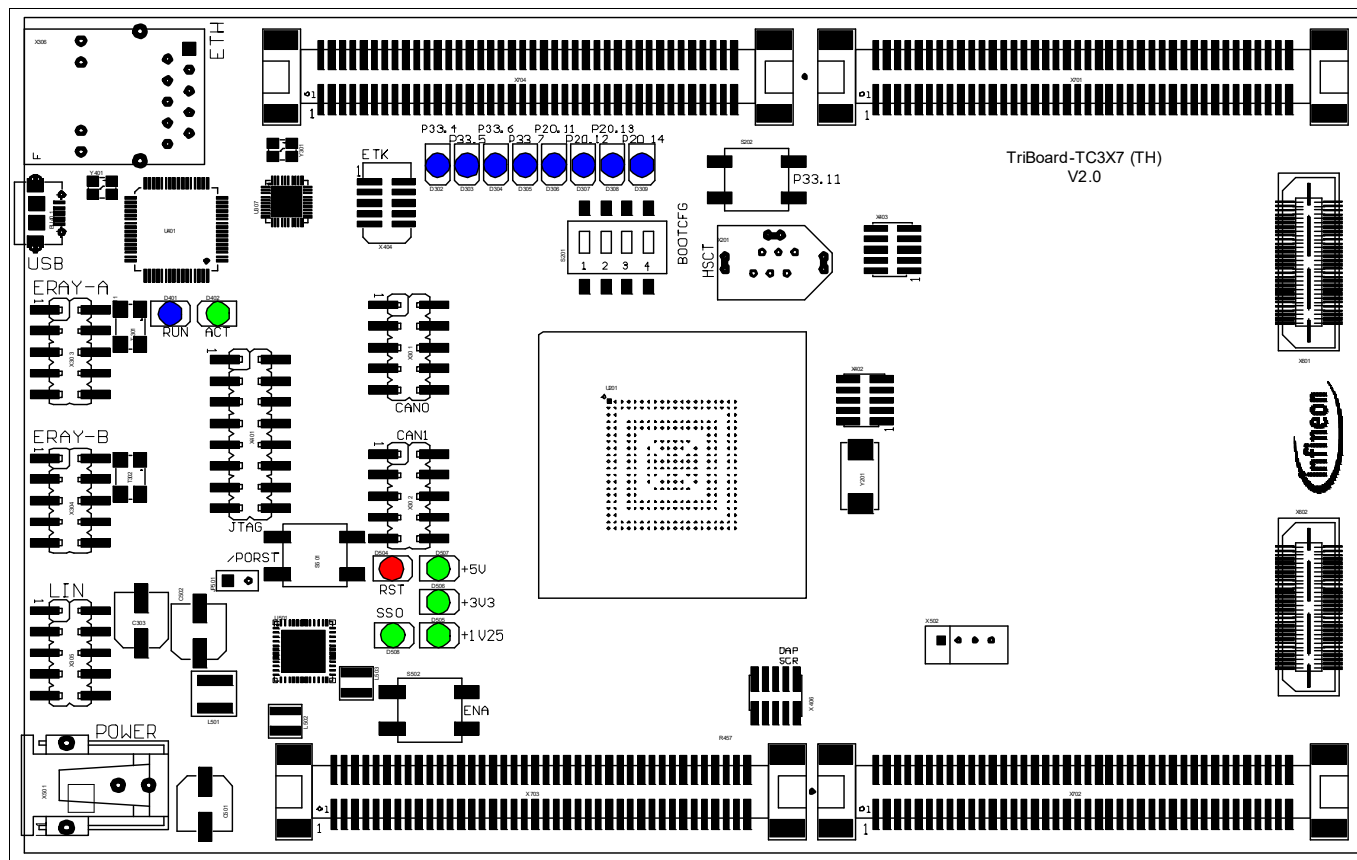

Figure 2-2 TriBoard TC3X7 ADAS (TH) V2.0 Placement

TriBoard Information

### 3 TriBoard Information

#### 3.1 Soldered board

TriBoard TC3X7 ADAS V2.0 is the soldered board and will be available only with usable devices. Please see also chapter [Usable devices](#).

#### 3.2 Socketed board

TriBoard TC3X7 TH V2.0 is the socketed board.

##### 3.2.1 Usable devices

*Note: Please check always the latest manual for complete list of usable/tested devices.*

The board can be used with the following devices:

- TC397 A-Step (only TC397XR and TC397XA)
- TC397 B-Step (only TC397XA, TC397XT and TC397QA)
- TC357
- TC337 (only TC337DA, TC337DT, TC337DH and TC337DZ)
- TC3A7 (planned, not yet tested)

##### 3.2.2 Restricted usable devices

- TC397 A-Step (except TC397XR and TC397XA)
- TC397 B-Step (except TC397XA, TC397XT and TC397QA)
- TC387
- TC377
- TC367
- TC337 (except TC337DA, TC337DT, TC337DH and TC337DZ)
- TC327
- TC3E7
  - RIF / MMIC not usable
  - Ethernet will not work
  - Select bootmode via DIP switch will not work
  - different pinning therefore following signals are different connected

Board signal name	TC397/ TC387/ TC377/ TC3E7 signal name	TC367 signal name	TC327/TC337LPsignal name
P00.0	P00.12	P00.12	P00.12
P00.1	AN47	AN47	NC
P00.2	AN46	AN46	NC
P00.3	AN41	AN41	NC
P00.4	AN40	AN40	NC
P00.5	AN38	AN38	AN38
P00.6	AN36	AN36	AN36
P00.7	AN45	AN45	NC
P00.8	AN44	AN44	NC



### TriBoard Information

Board signal name	TC397/ TC387/ TC377/ TC3E7 signal name	TC367 signal name	TC327/TC337LPsignal name
P00.9	AN37	AN37	AN37
P00.10	AN39	AN39	AN39
P00.11	AN33	AN33	AN33
P00.12	AN35	AN35	AN35
P02.0	P00.4	P00.4	P00.4
P02.1	P00.5	P00.5	P00.5
P02.2	P00.7	P00.7	P00.7
P02.3	P00.9	P00.9	P00.9
P02.4	P00.8	P00.8	P00.8
P02.5	P00.10	P00.10	P00.10
P02.6	P00.11	P00.11	P00.11
P02.7	AN43	AN43	NC
P02.8	AN42	AN42	NC
P10.0	P02.9	NC	NC
P10.1	P02.11	NC	NC
P10.2	P02.10	NC	NC
P10.3	P01.4	NC	NC
P10.4	P01.3	NC	NC
P10.5	P01.6	NC	NC
P10.6	P01.5	NC	NC
P10.7	P01.7	NC	NC
P10.8	P00.6	P00.6	P00.6
P11.2	P13.1	P13.1	P13.1
P11.3	P13.0	P13.0	P13.0
P11.9	P13.3	P13.3	P13.3
P11.10	P13.2	P13.2	P13.2
P11.11	P11.2	P11.2	P11.2
P11.12	P11.3	P11.3	P11.3
P50.0	P02.1	P02.1	P02.1
P50.1	P02.2	P02.2	P02.2
P50.2	P02.3	P02.3	P02.3
P50.3	P02.4	P02.4	P02.4
P50.4	P02.5	P02.5	P02.5
P50.5	P02.6	P02.6	P02.6
P50.6	P02.7	P02.7	P02.7
P50.7	P02.8	P02.8	P02.8
P50.8	P00.1	P00.1	P00.1
P50.9	P00.0	P00.0	P00.0

### TriBoard Information

Board signal name	TC397/ TC387/ TC377/ TC3E7 signal name	TC367 signal name	TC327/TC337LPsignal name
P50.10	P00.3	P00.3	P00.3
P50.11	P00.2	P00.2	P00.2
P51.0	P11.10	P11.10	P11.10
P51.1	P11.9	P11.9	P11.9
P51.2	P11.12	P11.12	P11.12
P51.3	P11.11	P11.11	P11.11
P51.4	P10.1	P10.1	P10.1
P51.5	P10.0	P10.0	P10.0
P51.6	P10.4	P10.4	P10.4
P51.7	P10.3	P10.3	P10.3
P51.8	P10.5	P10.5	P10.5
P51.9	P10.2	P10.2	P10.2
P51.10	P10.8	P10.8	P10.8
P51.11	P10.6	P10.6	P10.6
AN24	AN30	AN30	NC
AN25	AN31	AN31	NC
AN36	AN25	AN25	NC
AN37	AN26	AN26	NC
AN38	AN24	AN24	NC
AN39	AN27	AN27	NC
AN46	AN28	AN28	NC
AN44	AN29	AN29	NC
AN45	AN34	AN34	AN34
AN47	AN32	AN32	AN32

– Additional on TC377TX following signals are different connected

Board signal name	TC377TX signal name
P22.0	P22.10
P22.1	P22.11
P22.10	P22.0
P22.11	P22.1
P23.0	P23.2
P23.2	P23.3
P23.3	P22.12
VEXT (ball V19)	VFLEX2

### TriBoard Information

## 3.3 Power Supply

All needed voltages are generated via Infineon's Multi Voltage System Micro Processor Supply TLF30682QVS01.

The TLF30682QVS01 provide the following voltages:

+3,3V for TriCore (connected to VEXT and VEVR5B) and Ethernet Phy

+5V supply (used by CAN and FlexRay™ transceivers and is connected to VDDM and VAREFx)

+1,25V for TriCore (connected to VDD)

Applying a stable supply voltage causes the power on reset after a short period. The three LED's (+5V, +3.3V, +1V25) indicate the status of the on board generated voltages.

A manual power on reset is executed by pressing the reset button.

The Board has to be connected to a +3,5V to +40V DC power supply.

The power consumption is not specified yet but a supply with 12V and 500mA is recommended. The pinout for the supply connector is shown in [Figure 6-7](#). There can be used any standard power pack with a connector where the positive line is surrounded by the ground line.

*Note: The TLF30682QVS01 has a programmable voltage for the core supply. The default value for core supply is 1,20V. This can and must be changed to 1,25 V by software to avoid problems with undervoltage on VDD. For more information please see the corresponding Target Datasheet of TLF30682.*

### 3.3.1 Failsafe handling

In case that the device don't contains a program which disable or service the window watchdog of the TLF30682 then the TLF30682 is going to a FAILSAFE state where all supplies are switched off. This state can be left via reconnect the power plug or via the ENA button (S502). In this case you must connect a debugger which is able to disable the window watchdog to reprogram the microcontroller.

In the default state of the board the switching to FAILSAFE state is switched off via resistor R508 (0R).

If you will use/evaluate all safety features of the TLF30682 remove assembled R508. Make sure that you have a proper initialization of TLF30682 in your software. If needed you can assembled a 2,54mm jumper on JP501. With this jumper you can then enable the safety features (jumper open) or disable the safety features (jumper closed).

Resistor R508 and jumper JP501 are red marked in the following [Figure 3-1](#) and [Figure 3-2](#):

TriBoard Information

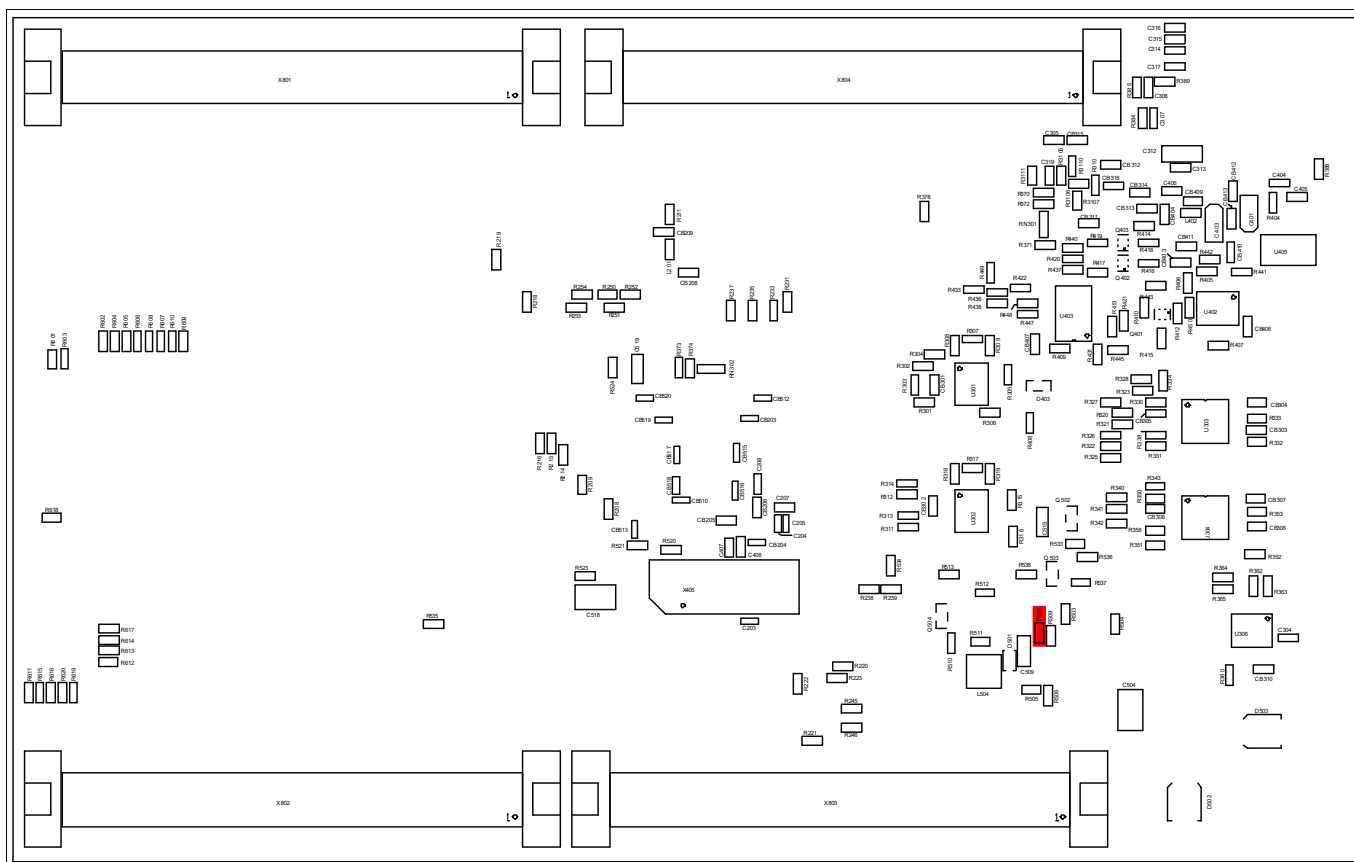

Figure 3-1 Resistor for TLF30682 Safety feature handling with switch on

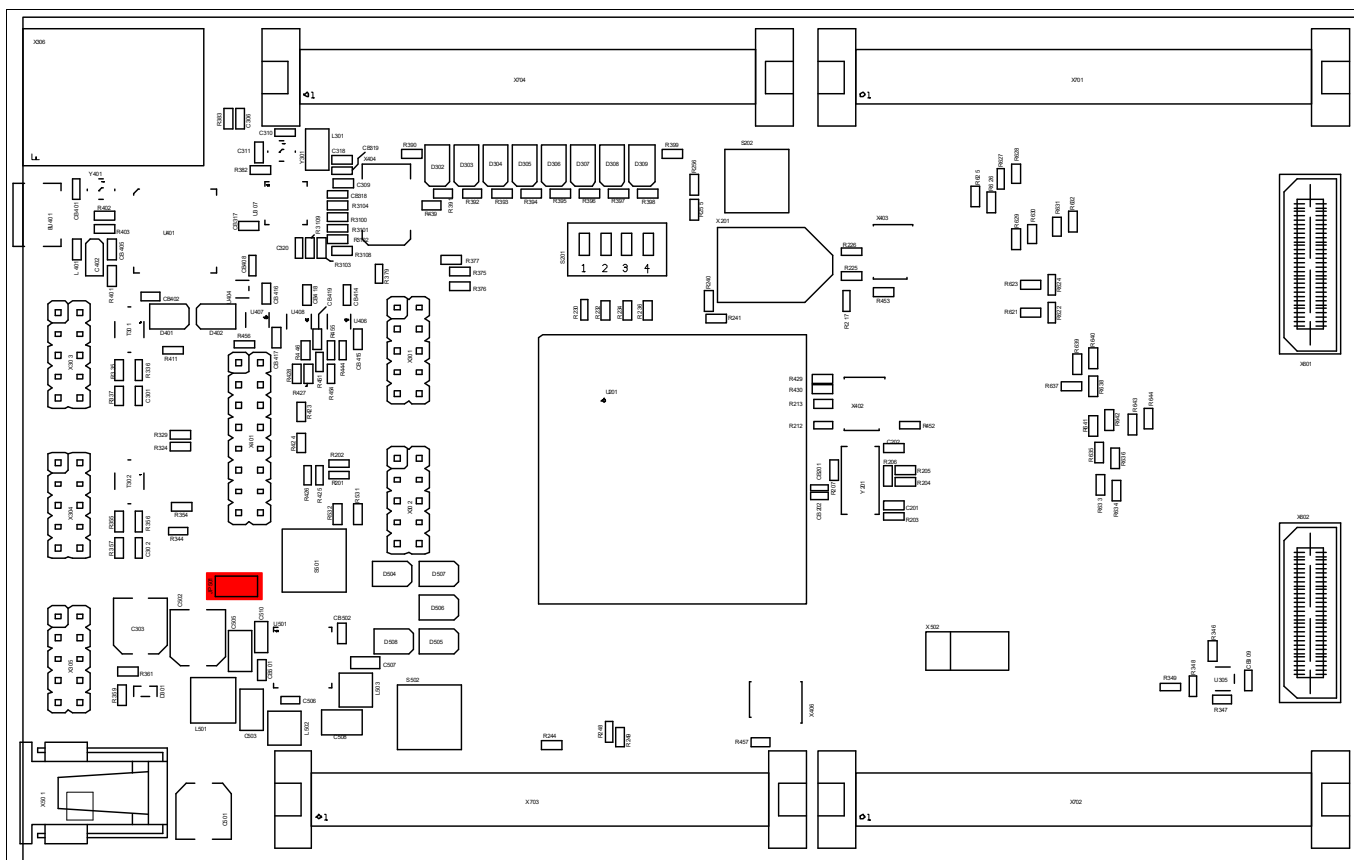

Figure 3-2 Jumper for TLF30682 Safety feature handling with switch on

### TriBoard Information

#### 3.4 LEDs

There are 15 LEDs on board:

- D302 up to D305 (blue) -> toggle LEDs connected to P33.4 ... P33.7
- D306 up to D309 (blue) -> toggle LEDs connected to P20.11 ... P20.14
- D504 RST (red) -> RESET LED indicate the reset state of the board (/ESR0)
- D505 +1V25 (green) -> +1V25 power supply indication
- D506 +3V3 (green) -> +3,3V power supply indication
- D507 +5V (green) -> +5V power supply indication
- D508 SSO (green) -> not usable, please ignore
- D402 ACT (green) -> on board miniWiggler JDS is ACTIV
- D401 RUN (blue) -> Debug RUN mode (switched by DAS Server)

#### 3.5 MMIC / RIF

The board has 2 High Speed Samtec QSH-030 connectors where you can connect a MMIC board. For the pinout of the connectors see [Figure 6-14](#). The description of the used port for each connector you can find in [Table 5-7](#).

*Note:* TC337 don't support P51/RIF1.

##### 3.5.1 Measurement RIF signals

The RIF signals (P50 and P51) are also connected to X701 and X801. If they make problems (e.g. many reflections on the lines) then you can disconnect the X701 and X801 and the signals are only usable/available on the MMIC/RIF connector.

On the TC3X7 ADAS Triboard these resistors are R621 up to R632 for P50 (RIF0) and R633 up to R644 for P51 (RIF1) (red marked in [Figure 3-3](#)). These resistors need to be removed.

TriBoard Information

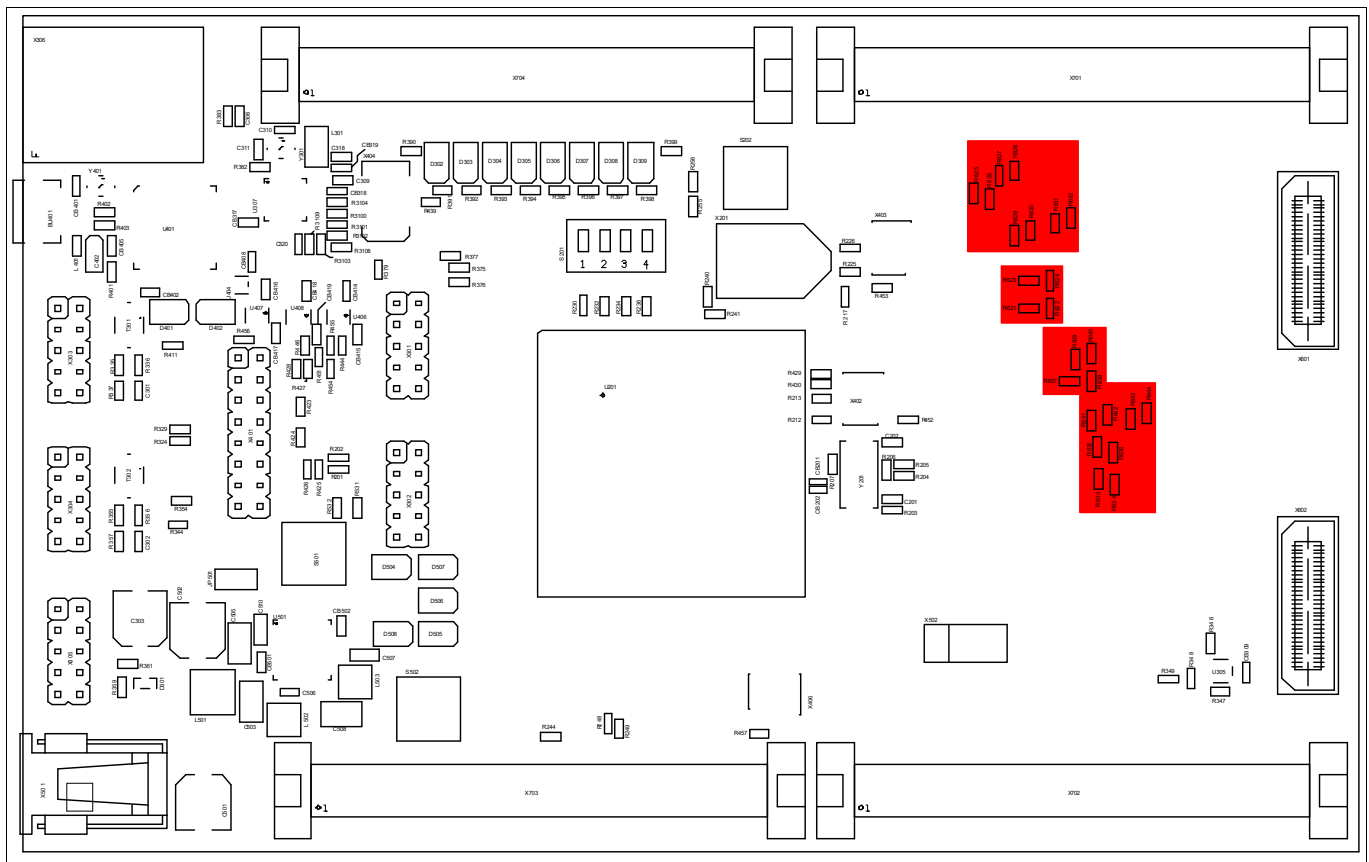

Figure 3-3 Resistors for measurement RIF signals on TriBoard TC3X7 ADAS (TH) V2.0

### 3.6 Clock

On the board is a fixed crystal with 20MHz assembled. You can change this by replacing Y101 (soldered).

### 3.7 USB Connector

The USB connector is used for connection to a PC. Via the USB it is possible to power the board, using the ASCLIN0 as serial connection via USB and Debugging via DAS. For the pinout of USB socket see [Figure 6-8](#).

NOTE: Before connecting the board to the PC, make sure that the actual DAS software is installed on the PC. For actual DAS software please contact your local FAE.

The software can also be found on:

[DAS website](#)

#### 3.7.1 Serial Connection to PC

After the first connection of USB to a PC the needed driver will be installed automatically. During this there will be created a new COM port on PC. This COM port can be used to communicate with the board via ASCLIN0 of the device. Per default the ASCLIN0 is used on P14.0 and P14.1 (e.g. Generic Bootstrap Loader) . In case you will use the Generic Bootstrap Loader via CAN or ASCLIN0 via P15.2 and P15.3 you must:

- remove R436 and R437 (this disconnect the serial connection from P14.0 and P14.1)
- remove R301 and R302 (this disconnect the CAN0 transceiver from P20.7 and P20.8)
- assemble R438 and R440 with 0R resistor (size 0603) to connect P15.2 and P15.3 to serial connection
- assemble R303 and R304 with 0R resistor (size 0603) to connect P14.0 and P14.1 to CAN0 transceiver

TriBoard Information

The mentioned resistors are red marked in [Figure 3-4](#).

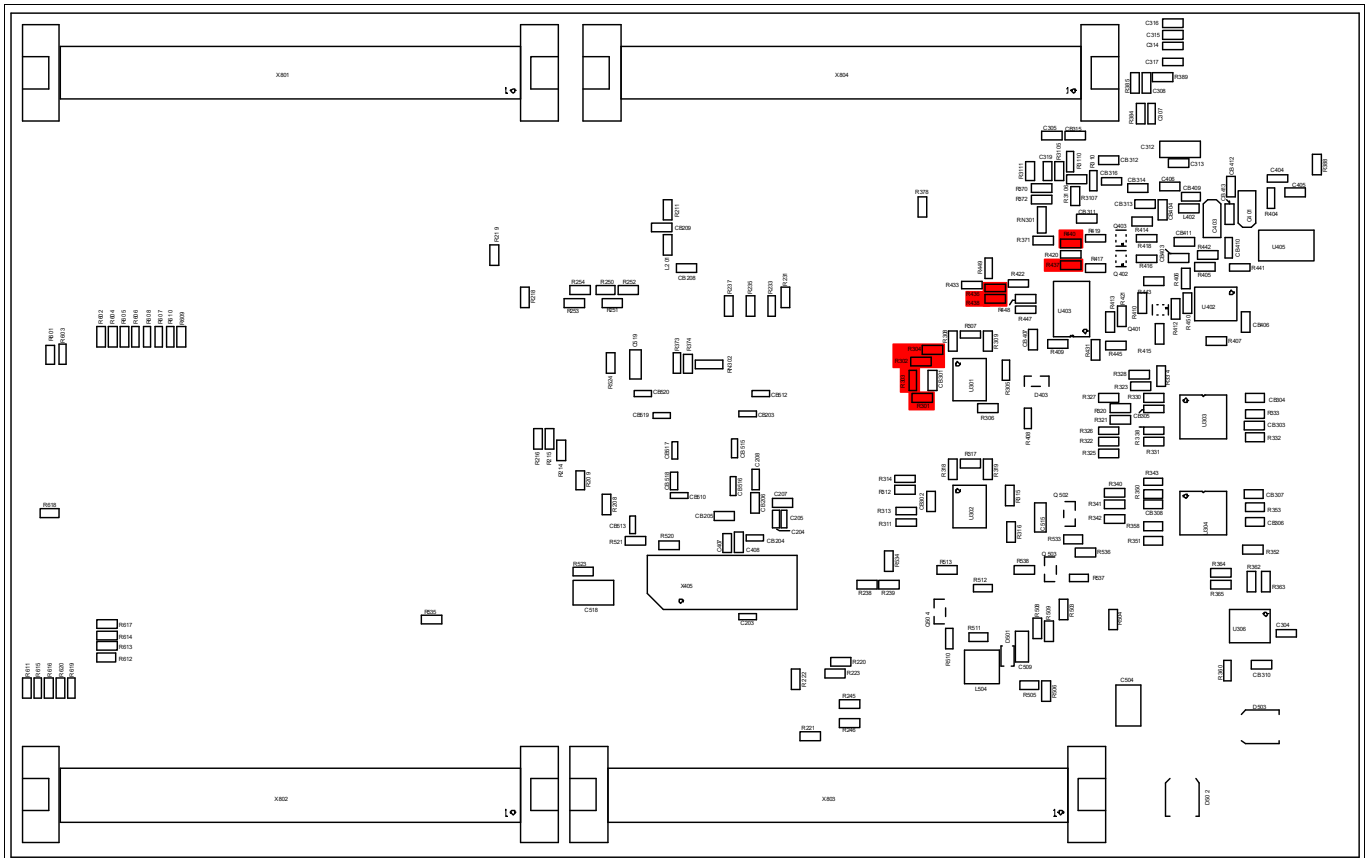

Figure 3-4 Resistors for ASC connection (ASC0)

### 3.7.2 miniWiggler JDS

The miniWiggler JDS is a low cost debug tool which allows you access to the JTAG of the device. Make sure that you have the latest DAS release. Debugging is possible via the DAS Server ‘UDAS’. Please contact your preferred debug vendor for support of DAS.

If you have connected the board to the PC and there runs the DAS server, then a working connection is visible via the green ACTIV LED.

The status RUN LED is switched on/off through the DAS Server, depending on the used debugger (client).

**IMPORTANT: Make sure that there is no or a tristated connection on X401 (OCDS1) and X402 (DAP) if the ACTIV LED is on.**

Per default the miniWiggler is connected to the DAP. It is possible to change the connection to DAPE (DAP of emulation device if available). If resistors R214, R215 and R216 assembled (default) then the standard DAP is connected to miniWiggler otherwise if R217, R218 and R219 are assembled the the DAPE of emulation device is connected to miniWiggler. Please note that there should be connected only standard DAP or DAPE. If all this resistors are not assembled then the miniWiggler can't be used. In this case only the DAP connectors X402 and X403 can be used. See [Table 3-9](#) and [Table 3-10](#).

### 3.8 FlexRay™ (E-RAY)

The board has 2 IDC10 plugs for FlexRay™ Communication (channel A and B) with up to 10 Mbit/s. For the pinout of the plugs see [Figure 6-9](#). You can use a IDC female connector with crimpconnector, flat cable and SUB-D 9 plug with crimpconnector to have a 1:1 adapter to SUB-D 9.

## TriBoard Information

The transceiver are connected to the TriCore device via zero ohm resistors (R325 up to R329 and R340 up to R344) which must be removed to use the ports outside.

ERAY-A can be connected to P14.8, P14.9 and P14.10 (default, usable with ERAY0 and ERAY1) and to P02.0, P02.1 and P02.4 (only usable with ERAY0). Transceiver for channel A can be enabled/disabled via P32.3 (default) or via P10.2. The error state of transceiver channel A can be read out via P32.2 (default) or via P10.1.

ERAY-B is connected to P14.5, P14.6 and P14.7 (default, usable with ERAY0 and ERAY1). Transceiver for channel A can be enabled/disabled via P20.10 (default). The error state of transceiver channel A can be read out via P20.9 (default).

For more information look in the user manual for TC3X7.

*Note:* TC337 and TC3A7 don't support FlexRay™.

### 3.9 Serial Eeprom

*Note:* TC337 don't have I2C module. Access to the eeprom only with simulation of I2C protocol via bit banging possible.

The I<sup>2</sup>C via P15.4 and P15.5 of the TC3X7 is connected to a serial EEPROM with a size of 2KBit (2 x 128 x 8). The slave address of this EEPROM is 0x50. The upper half of the array (80h-FFh) is permanently write-protected. Write operations to this address range are inhibited. Read operations are not affected. This upper half contains a pre-programmed EUI-48™ node address which can be used as MAC ID for Ethernet. The other 128 bytes are writable by customer.

To disconnect (disable) the EEPROM remove resistor R348 and R349.

### 3.10 MultiCAN

On the board are two CAN transceiver connected to the CAN0 and CAN1 of TC3X7. The transceivers are connected to two IDC10 plug. For the pinout of IDC10 plug see [Figure 6-10](#). You can use a IDC female connector with crimpconnector, flat cable and SUB-D 9 plug with crimpconnector to have a 1:1 adapter to SUB-D 9.

The transceiver are connected to the TriCore device via zero ohm resistors (R301 up to R304 and R311 up to R314) which must be removed to use the ports outside.

CAN0 can be used via P20.7 and P20.8 (node 0, default) or P14.0 and P14.1 (node 1). CAN1 can be used via P23.0 and P23.1 (node 0, default) or P00.0 and P00.1 (node 0).

*Note:* CAN1 is not usable with TC337 and TC3A7.

### 3.11 LIN

On the board is one LIN transceiver connected to the ASCLIN1 on TC3X7 (P15.0 and P15.1). The transceiver are connected to one IDC10 plug. For the pinout of IDC10 plug see [Figure 6-11](#). You can use a IDC female connector with crimpconnector, flat cable and SUB-D 9 plug with crimpconnector to have a 1:1 adapter to SUB-D 9.

To disconnect the LIN remove resistor R364 and R365.

The LIN can be used in master and in slave mode. For the master mode there is per default a pull-up of 1K (R360) and a capacitor of 1nF (C304) on the BUS assembled. For using the LIN in slave mode the pull-up resistor R360 must be removed and maybe the capacitor changed to a smaller value (e.g. 220pF).

The mentioned resistor and capacitor are red marked in [Figure 3-5](#)



TriBoard Information

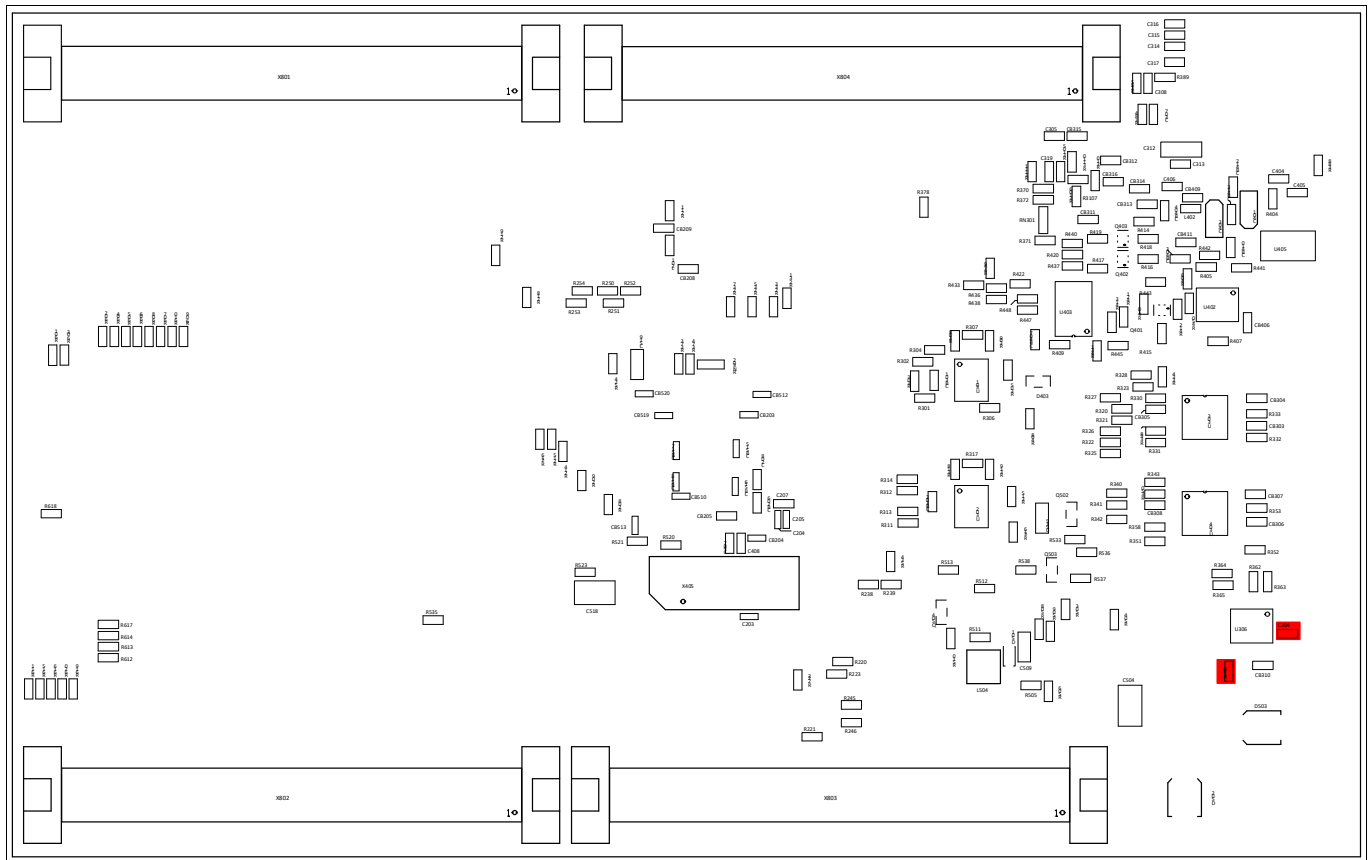

Figure 3-5 Components for LIN Master Mode

### 3.12 Ethernet

The TriBoard provide a RJ45 connector (X306) for twisted pair ethernet connections. The TriBoard use a Realtek Integrated 10/100/1000M Ethernet Precision Transceiver RTL8211FI-CG as physical interface device. For more information about the ethernet modul see TC3X9 User’s Manual, about the PHY see the RTL8211F datasheet. For the pinout of RJ45 see [Figure 6-13](#).

The PHY is connected to the TriCore device via resistors and resistor arrays (R370 up to R374 and RN301 up to RN302).

For the connection between TriCore and PHY is used RGMII.

*Note: Please note that the used signals for RGMII (P11.0 up to P11.12) are not connected to any connector.*

### 3.13 HSCT (optional)

The TriBoard provide a footprint of IEEE 1394 socket (X201) for connection to other TC3XX via HSCT.

*Note: Don’t use X201 for connection to any IEEE 1394 device, this can destroy the board and/or the connected device.*

For connect two TriBoards you need to assemble this socket (Lumberg 2415 01) on each board and connect the boards with a standard 6 pin IEEE 1394 cable. For the pinout of socket see [Figure 6-12](#).

*Note: TC357 and TC337 don’t support HSCT.*

TriBoard Information

Note: HSCT1 of TC397B and TC3A7 is not connected to special socket.

### 3.13.1 High speed with HSCT

For use the HSCT connection between two board you need to remove 5 resistors to have a very short connection between device and connector. On the TC3X7 ADAS Triboard this 5 resistors are R250, R251, R252, R253 and R254 (red marked in [Figure 3-6](#)). This resistors needs to be removed.

Important: When the resistors are removed then the port signals P20.0, P21.2, P21.3, P21.4 and P21.5 are no longer available on the 80 pin samtec connectors.

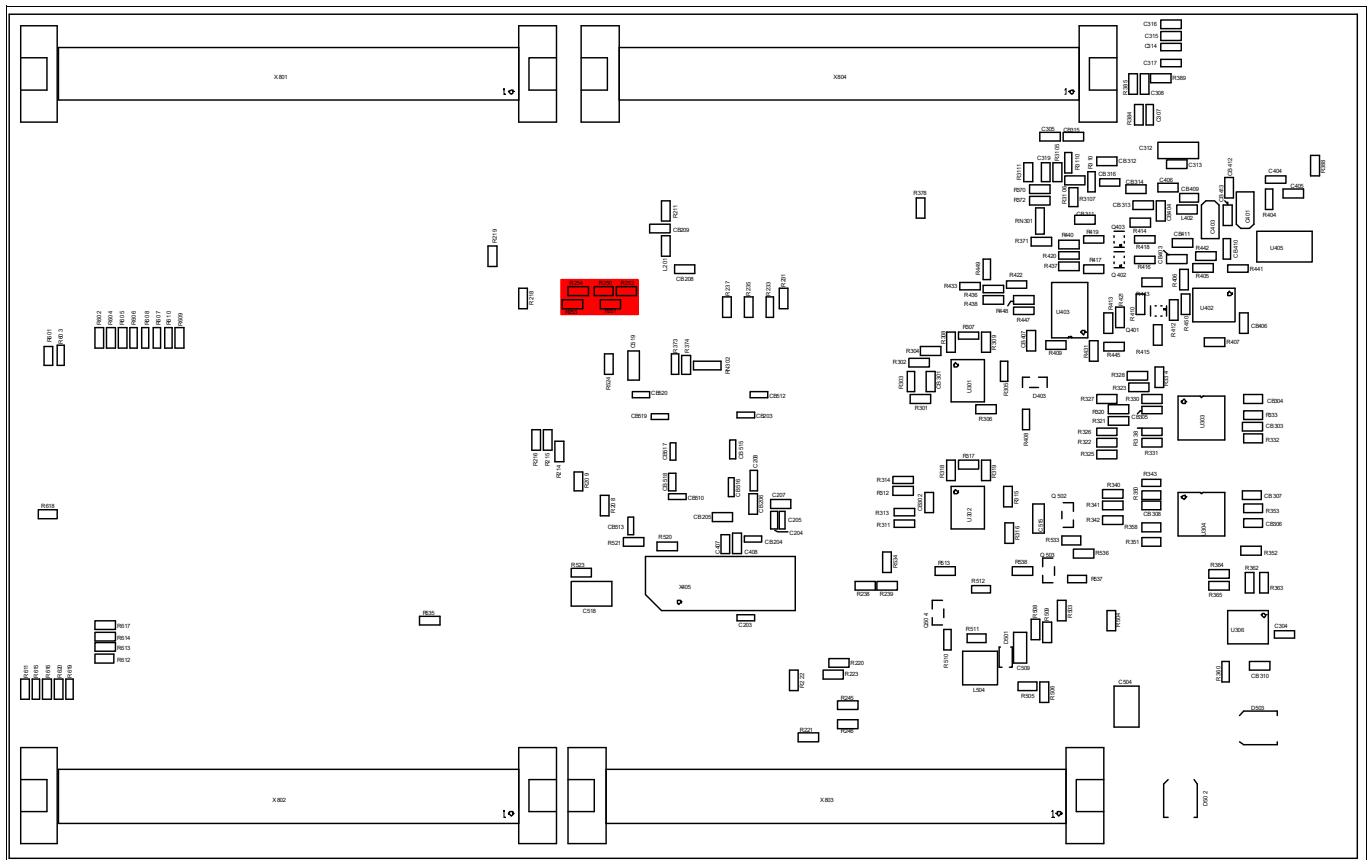

Figure 3-6 Resistors for high speed HSCT

### 3.14 ADC

On this boards are 5 ADC channels prepared with a low pass filter. On pin AN7, AN20, AN21, AN44 and AN45 is assembled a capacitor of 47nF and a serial resistor of 4,7K. The filter components are red marked in the following figures ([Figure 3-7](#) and [Figure 3-8](#)).

Note: On TC357 is only AN7 available. AN20, AN21, AN44 and AN45 are not available

TriBoard Information

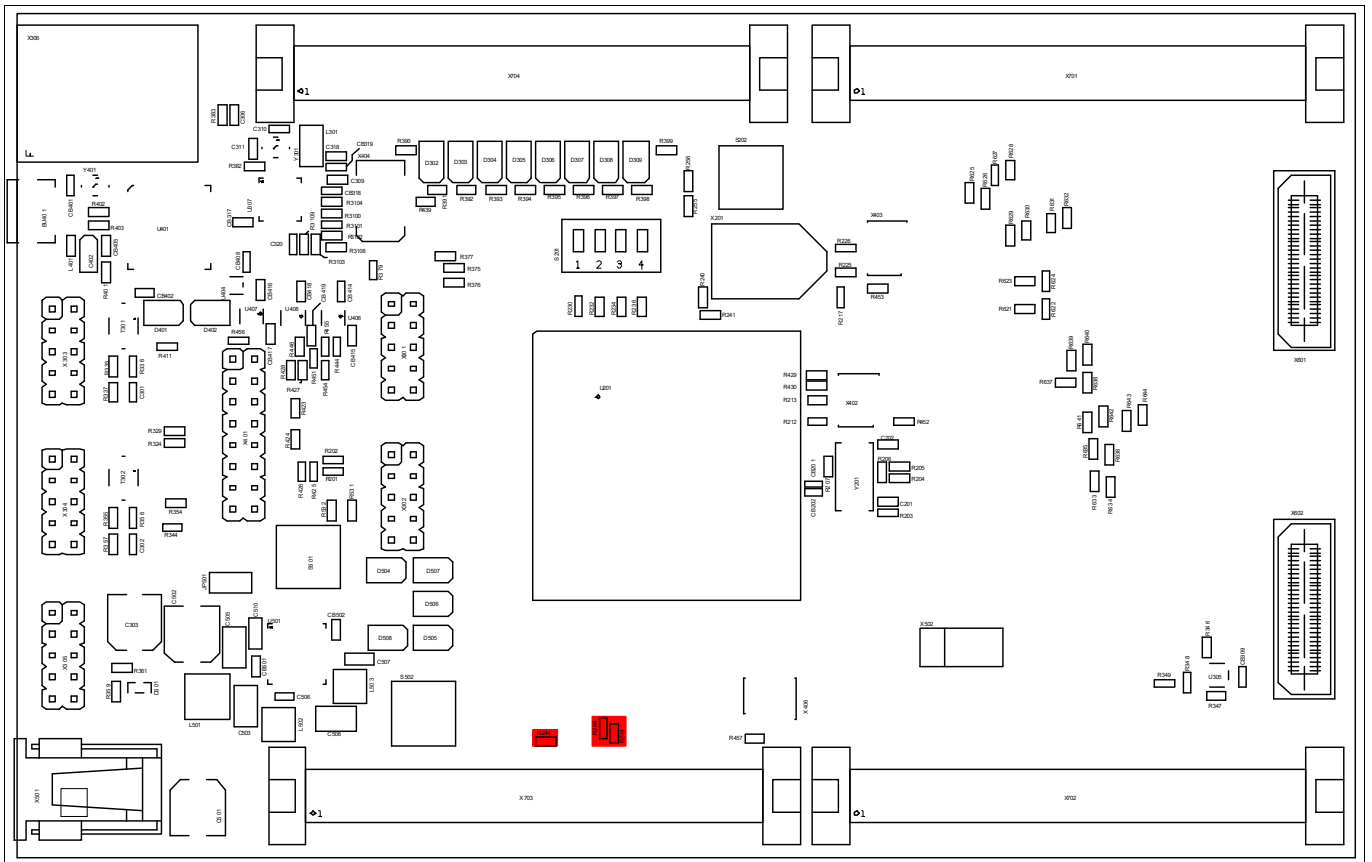

Figure 3-7 Filter components of ADC channels on Top Side

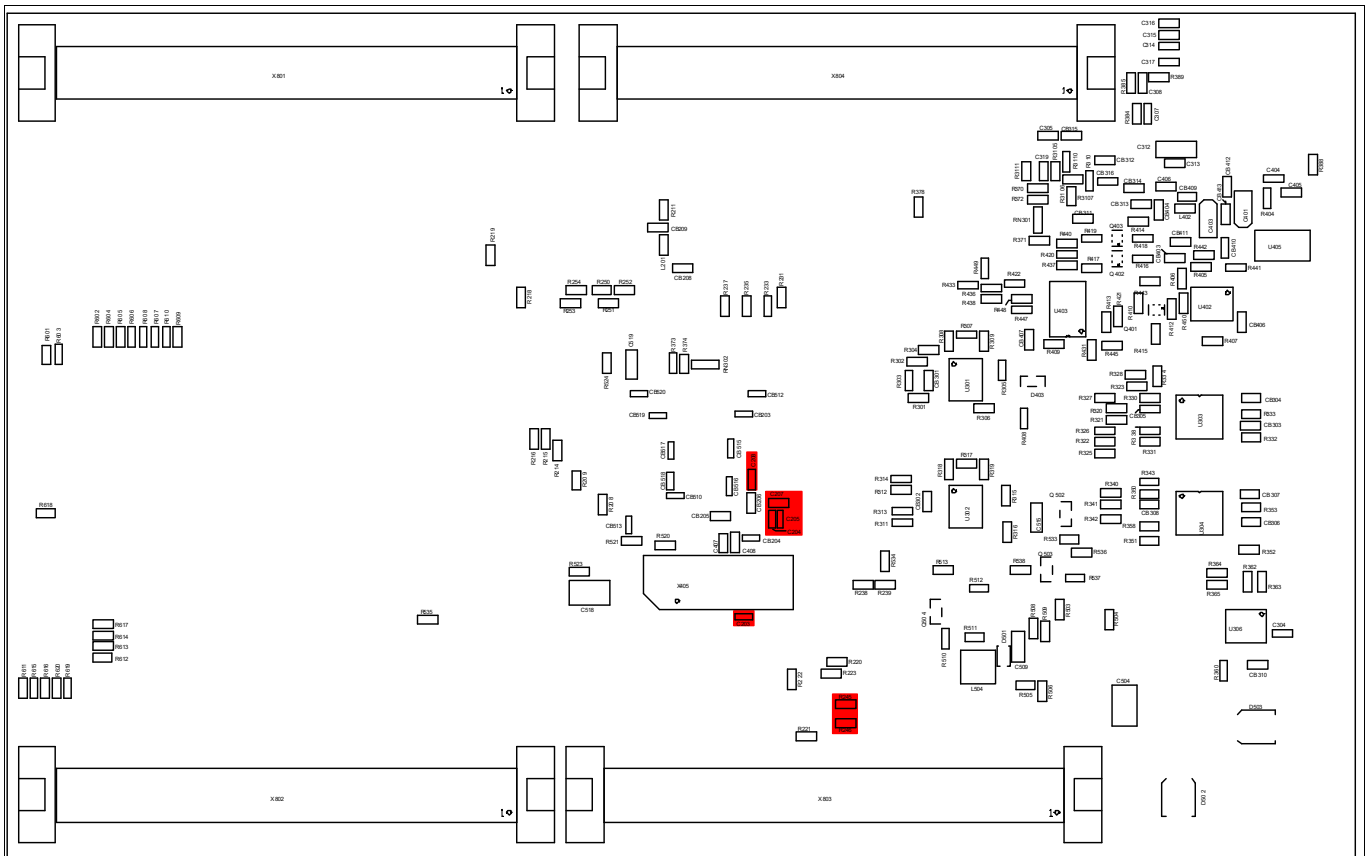

Figure 3-8 Filter components of ADC channels on Bottom Side

**TriBoard Information****3.15 Other peripherals**

For all other peripherals there are no special plugs on the board. The peripheral signals are available on the different connectors. See [“Connector Pin Assignment” on Page 6-1](#).

**3.16 Toggle LED's**

The status LED's are low active and can be controlled by Software.

Port 20 pin 11 up to pin 14 are connected to single LED's (D306... D309) and powered by the normal microcontroller voltage.

Port 33 pin 4 up to pin 7 are connected to single LED's (D302... D305) and also powered by the normal microcontroller voltage because VEVR SB is connected to 3,3V (port 33 is powered by VEVR SB pin which is connected to 3,3V of TLF30682).

**3.17 Buttons**

On the board are three buttons.

The reset button (S501) will apply a warm power on reset to the device.

The ENA button (S502) will be used to enable/wakeup the TLF30682.

The P33.11 button (S202) can be used by software as input.

**3.18 Debug System****3.18.1 OCDS1**

The OCDS1 signals are connected to the IDC16 plug (X401). They work with the port supply of Microcontroller (+5V default or +3,3V). For pinout of the connector see [Figure 6-15](#). You can connect any debugger to this connector.

The signals /BRKIN and /BRKOUT are not connected per default. If you need this signals in the connector then assemble R424 and R425 or R426 with a 0R resistor.

If you connect a debug hardware make sure that the miniWiggler JDS (see [“miniWiggler JDS” on Page 3-8](#)) is not activ (ACTIV LED is off) and on the DAP connector (X402) is no hardware connected or the hardware is tristated.

If the ACTIV LED is on, then stop the active DAS Server 'UDAS' and/or remove the USB connection to the PC.

In case that R217, R218 and R219 are assembled instead of R214, R215 and R216 then the connector can be used only for DAP connection to DAPE. If R214 up to R219 not assembled then the connector is not usable.

**3.18.2 DAP**

The board comes with a DAP connector (X402). For pinout of this connector see [Figure 6-16](#). You can connect a DAP hardware here. If you use this connector make sure that the miniWiggler JDS is not activ (ACTIV LED is off) and a connected OCDS1 hardware is disconnected or tristated.

**3.18.3 DAPE (only Emulation Device)**

The board comes also with another DAP connector (X403) which is connected to DAPE in case that an emulation device is used. For pinout of this connector see [Figure 6-16](#). You can connect a DAP hardware here. If you use this connector make sure that the miniWiggler JDS is not activ (ACTIV LED is off) and a connected OCDS1 hardware is disconnected or tristated in case that R217, R218 and R219 are assembled.

TriBoard Information

3.18.4 DAP\_SCR

Additional DAP connector (X406) is connected to DAP\_SCR. This DAP can be used as private DAP connection to the standby controller. For pinout of this connector see [Figure 6-16](#). You can connect a DAP hardware here. This DAP use P33.6 and P33.7 which are connected to LED on the board. Maybe it is necessary to remove R393 and R394 if the speed of the connection is not fast enough.

3.19 High speed with DAP/DAPE

For use the DAP connection with 160 MHz you need to remove 3 resistors to have a very short connection between device and connector. On the TC3X7 ADAS Triboard this 3 resistors are R214, R215 and R216 for DAP or R217, R218 and R219 for DAPE (red marked in [Figure 3-9](#) and [Figure 3-10](#)). This resistors needs to be removed.

**Important: When the resistors are removed then only the DAP and DAPE connector on the board can be used. The on board wiggler and the OCDS1 connector couldn't be use (are disconnected) in this case, also the DAP/JTAG part of AGBT connector and the ETK connector couldn't be used.**

All resistors are red marked in the following figures:

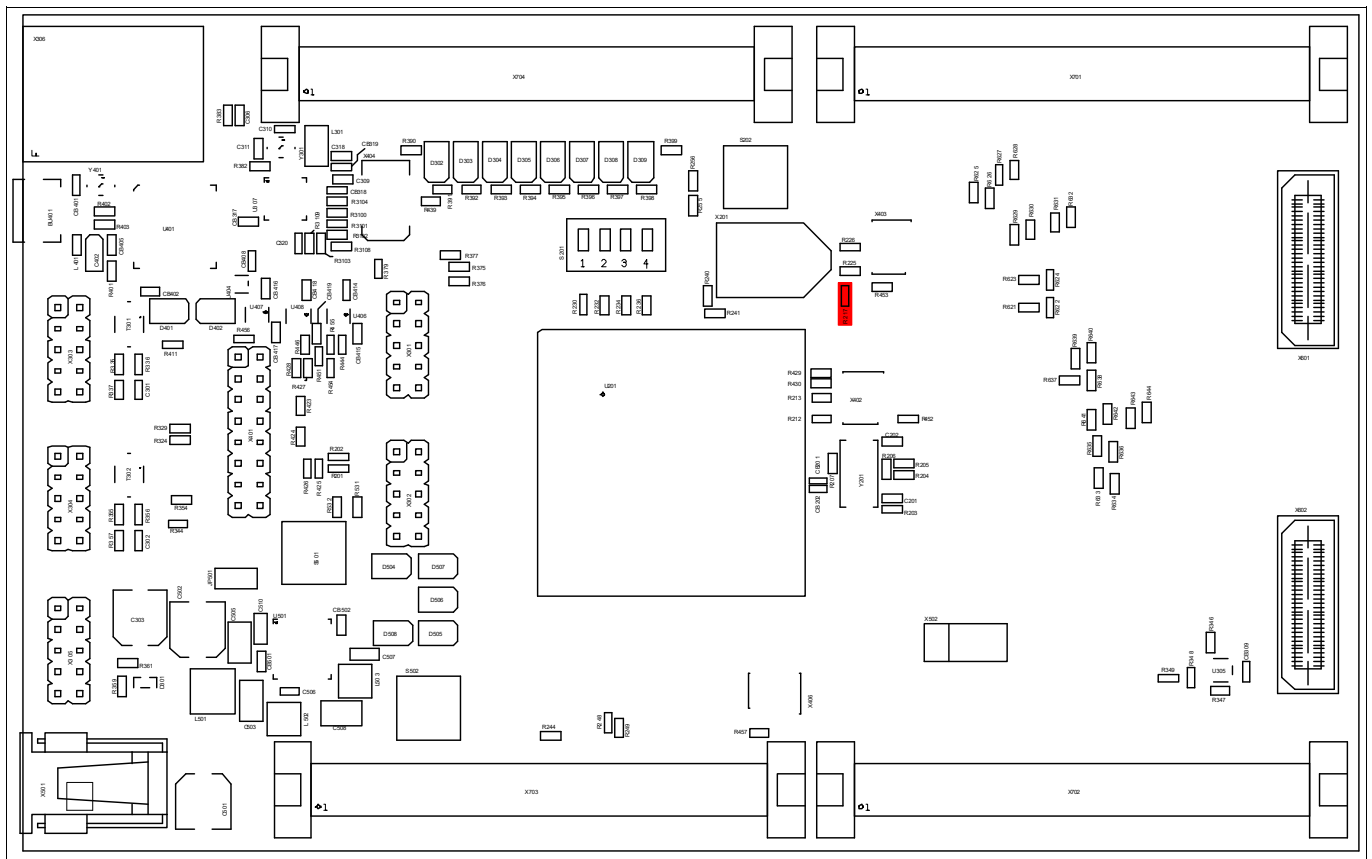

Figure 3-9 Location of DAP resistors on Top Side

TriBoard Information

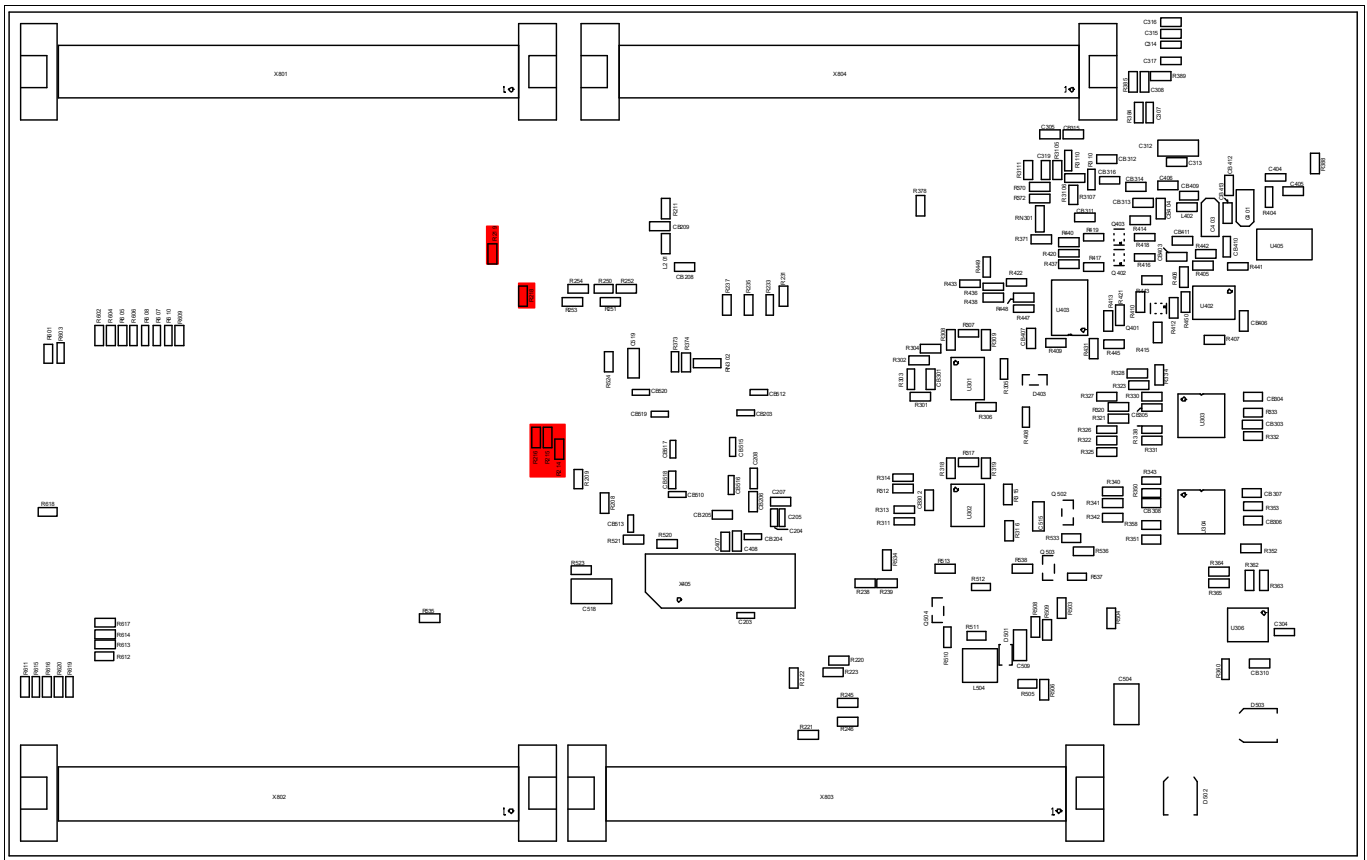

Figure 3-10 Location of DAP resistors on Bottom Side

3.19.1 AGBT (optional)

The TriBoard provide a 22 pin high speed samtec connector (X405) for highest speed connection via AGBT. This connector should be assembled by your self if needed.

The AGBT interface is only available on emulation devices.

For the pinout of connector see [Figure 6-19](#).

The needed Samtec connector is: ASP-137969-01 (serie ERM8, Nexus HS22).

*Note: The robustness of AGBT communication depends on the PCB high-speed design quality and the physical connection of a microcontroller on the board. It is highly recommended to use boards with properly soldered microcontrollers for the highest reliability of the AGBT in the full operating range.*

3.19.2 ETK connector (optional)

The TriBoard provide a 10 pin samtec connector (X404) for connecting to an ETK. This connector should be assembled by your self if needed.

For the pinout of connector see [Figure 6-17](#).

The needed Samtec connector is: TFM-105-02-A.

### TriBoard Information

#### 3.19.3 EmW Power (optional)

The TriBoard provide the 4 pin power connector (X502) for the Ethernet miniWiggler (EmW). This connector should be assembled by your self if needed.

For the pinout of connector see [Figure 6-18](#).

The needed Samtec connector is the JST B4B-PH-K.

The connector provide the input voltage to the Ethernet miniWiggler and an enable/wakeup signal connected to TLF30682 and a standby voltage of +1,25V which is not connected to the device on this board.

TriBoard Configuration

## 4 TriBoard Configuration

### 4.1 HW Boot Configuration

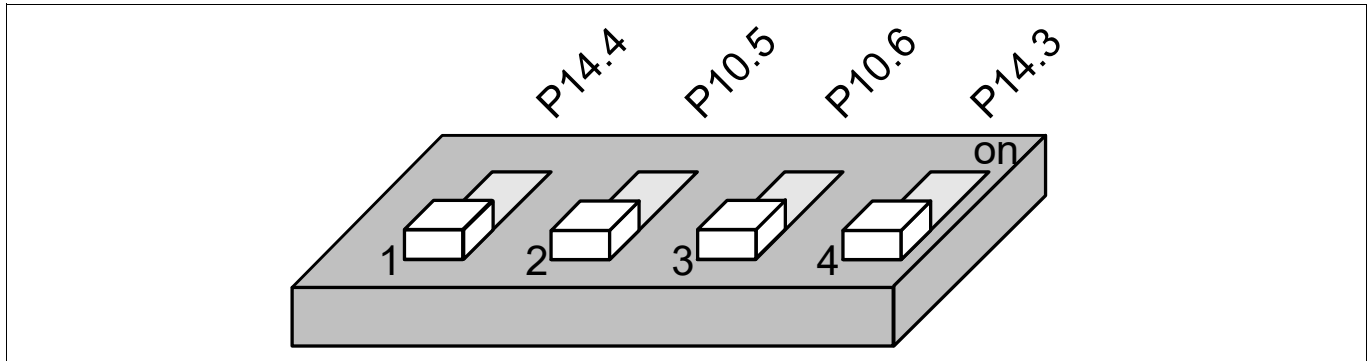

Figure 4-1 HW Configuration DIP-Switches

The picture above shows the definition of the boot HW configuration switch. The meaning of the switches will be described in the following table (Table 4-1).

Note: The ON position of the switch is equal to a logical LOW at the dedicated pin.

#### 4.1.1 Default Pad State

P14.4 / HWCFG6 is used to select the Default Pad State. Dipswitch 1 used to select this.

In case that dipswitch1 is set to ON then all I/O pins are in tristate otherwise the internal pull-up devices are enabled on the I/O pins. Please note that after change Dipswitch 1 you must make a power cycle (switch off -> switch on) to use the new configuration.

In case that TriState is selected (Dipswitch 1 is set to ON) then the I/O pins are floating. If you need a specific level on different pins during startup (e.g. driver pins) then you must add the needed pull device (up or down). Some pins (especially the HWCFG pins) haven always the needed external pull-up and/or pull-down resistor assembled on the board.

#### 4.1.2 Bootmode

Table 4-1 User Startup Modes <sup>1)2)3)</sup>

HWCFG[5...3]	Type of Boot	2	3	4
XX1	Start-up mode is selected by Boot Mode Index	X	X	OFF
110	Internal Start from Flash	OFF	OFF	ON
100	Alternate Boot Mode, Generic Bootstrap Loader on fail (P14.0/P14.1)	ON	OFF	ON
010	Alternate Boot Mode, ASC Bootstrap Loader on fail (P15.2/P15.3)	OFF	ON	ON
000	Generic Bootstrap Loader (P14.0/P14.1)	ON	ON	ON

1) The shadowed line indicates the default setting.

2) 'x' represents the don't care state.

3) 2 to 4 are the Dip Switch numbers.



## TriBoard Configuration

## 4.2 Assembly Options

### 4.2.1 General optional resistors

**Table 4-2 General optional resistors (default assembly in brackets)**

Component	Description
R202	Connect P20.2 (/TESTMODE) to GND (not assembled)
R203	XTAL1 Rload (50 Ohm) (not assembled)
R206	XTAL Rparallel (not assembled)
R207	XTAL2 Rserial (assembled)
R238	Switch off EVRC (assembled)
R240	Switch off EVR33 (assembled)
R390	Connect +3V3 to toggle LEDs D302...D305 (assembled)
R399	Connect +3V3 to toggle LEDs D306...D309 (assembled)
R423	Connect P20.0 with miniWiggler JDS (not assembled)
R424	Connect P20.0 with OCDS1 connector (not assembled)
R425	Connect P20.1 with OCDS1 connector (not assembled)
R426	Connect P20.2 with OCDS1 connector (not assembled)
R427	Connect P20.1 with USR1 of miniWiggler JDS (not assembled)
R428	Connect P20.2 with USR1 of miniWiggler JDS (not assembled)
R429	Connect P21.6 (DAP3) with USR1 of DAP (assembled)
R430	Connect P20.2 with USR1 of DAP (not assembled)
R433	Connect P20.1 with ETK connector (not assembled)
R439	Connect P21.7 with ETK connector (not assembled)
R508	Connect pin MPS of TLF30682 to +3V3 (assembled)
R524	Connect VDDP3 to +3V3 (assembled)

*Note: All resistors are red marked in the following figures.*

### TriBoard Configuration

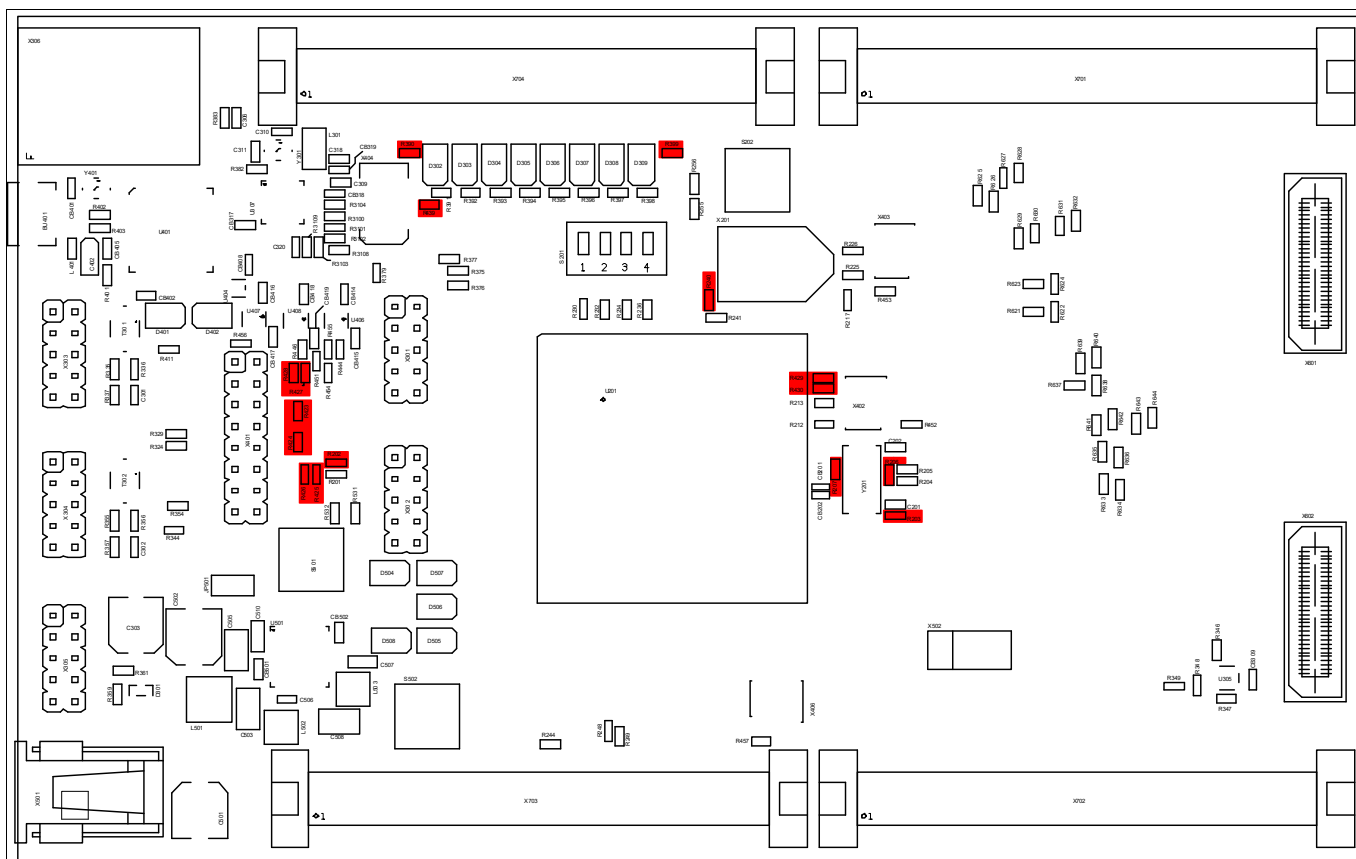

**Figure 4-2** Location of general optional resistors on Top Side

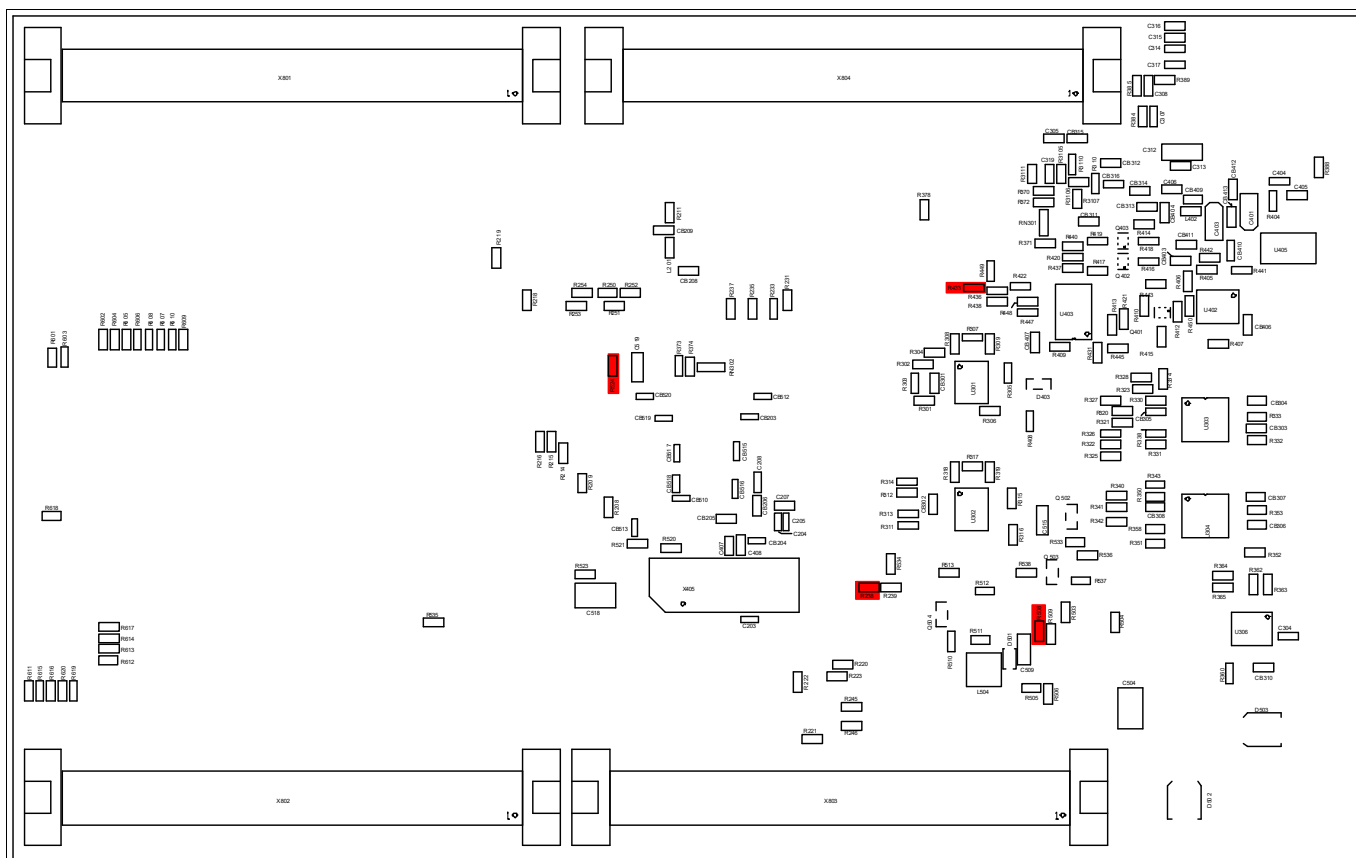

**Figure 4-3** Location of general optional resistors on Bottom Side

## TriBoard Configuration

## 4.2.2 Resistors for peripherals

Table 4-3 Resistors for peripherals (default assembly in brackets)

Component	Description
R220	Connect +5V with VDDM (assembled)
R221	Connect +3V3 with VDDM (not assembled)
R222	Connect VAREF1 with VDDM (assembled)
R223	Connect VAREF2 with VDDM (assembled)
R301	Connect P20.7 with RXD of CAN0 transceiver (assembled)
R302	Connect P20.8 with TXD of CAN0 transceiver (assembled)
R303	Connect P14.1 with RXD of CAN0 transceiver (not assembled)
R304	Connect P14.0 with TXD of CAN0 transceiver (not assembled)
R311	Connect P23.0 with RXD of CAN1 transceiver (assembled)
R312	Connect P23.1 with TXD of CAN1 transceiver (assembled)
R313	Connect P00.1 with RXD of CAN1 transceiver (not assembled)
R314	Connect P00.0 with TXD of CAN1 transceiver (not assembled)
R320	Connect P14.10 with TXD of ERAY-A transceiver (assembled)
R321	Connect P14.9 with TXDEN of ERAY-A transceiver (assembled)
R322	Connect P14.8 with RXD of ERAY-A transceiver (assembled)
R323	Connect P32.3 with EN of ERAY-A transceiver (assembled)
R324	Connect P32.2 with ERRN of ERAY-A transceiver (assembled)
R325	Connect P02.1 with RXD of ERAY-A transceiver (not assembled)
R326	Connect P02.4 with TXDEN of ERAY-A transceiver (not assembled)
R327	Connect P02.0 with TXD of ERAY-A transceiver (not assembled)
R328	Connect P10.2 with EN of ERAY-A transceiver (not assembled)
R329	Connect P10.1 with ERRN of ERAY-A transceiver (not assembled)
R340	Connect P14.5 with TXD of ERAY-B transceiver (assembled)
R341	Connect P14.6 with TXDEN of ERAY-B transceiver (assembled)
R342	Connect P14.7 with RXD of ERAY-B transceiver (assembled)
R343	Connect P20.10 with EN of ERAY-B transceiver (assembled)
R344	Connect P20.9 with ERRN of ERAY-B transceiver (assembled)
R348	Connect P15.4 with SCL of I2C Eeprom (assembled)
R349	Connect P15.5 with SDA of I2C Eeprom (assembled)
R364	Connect P15.1 with RXD of LIN1 transceiver (assembled)
R365	Connect P15.0 with TXD of LIN1 transceiver (assembled)
R310	Connect P11.5 with CLOCKOUT of Ethernet PHY (assembled)
R370	Connect P11.12 with RXC of Ethernet PHY (assembled)
R371	Connect CLKOUT of Ethernet PHY with TXC of Ethernet PHY (not assembled)
R372	Connect P11.11 with RXCTL of Ethernet PHY (assembled)
R373	Connect P11.4 with TXC of Ethernet PHY (assembled)

**TriBoard Configuration**

**Table 4-3 Resistors for peripherals (default assembly in brackets) (continued)**

Component	Description
R374	Connect P11.6 with TXCTL of Ethernet PHY (assembled)
R375	Connect P12.1 with MDIO of Ethernet PHY (assembled)
R376	Connect P12.0 with MDC of Ethernet PHY (assembled)
R377	Connect P15.8 with MDINT of Ethernet PHY (not assembled)
RN301	Connect P11.7...10 with RDX3...0 of Ethernet PHY (assembled)
RN302	Connect P11.0...3 with TDX3...0 of Ethernet PHY (assembled)
R436	Connect P14.0 with RXD of USB to UART (assembled)
R437	Connect P14.1 with TXD of USB to UART (assembled)
R438	Connect P15.2 with RXD of USB to UART (not assembled)
R440	Connect P15.3 with TXD of USB to UART (not assembled)

*Note: All resistors are red marked in the following figures*

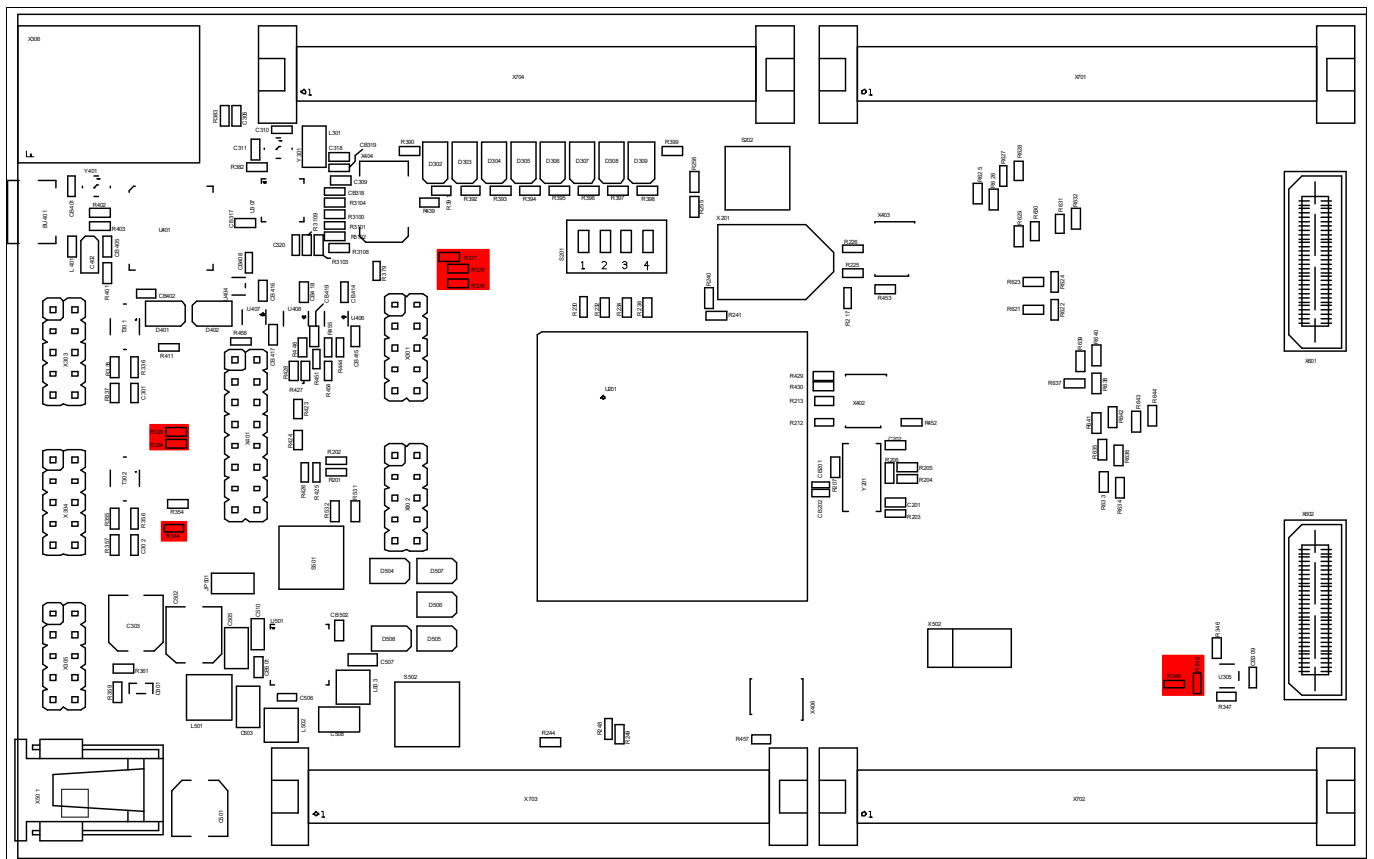

**Figure 4-4 Location of peripheral resistors on Top Side**

TriBoard Configuration

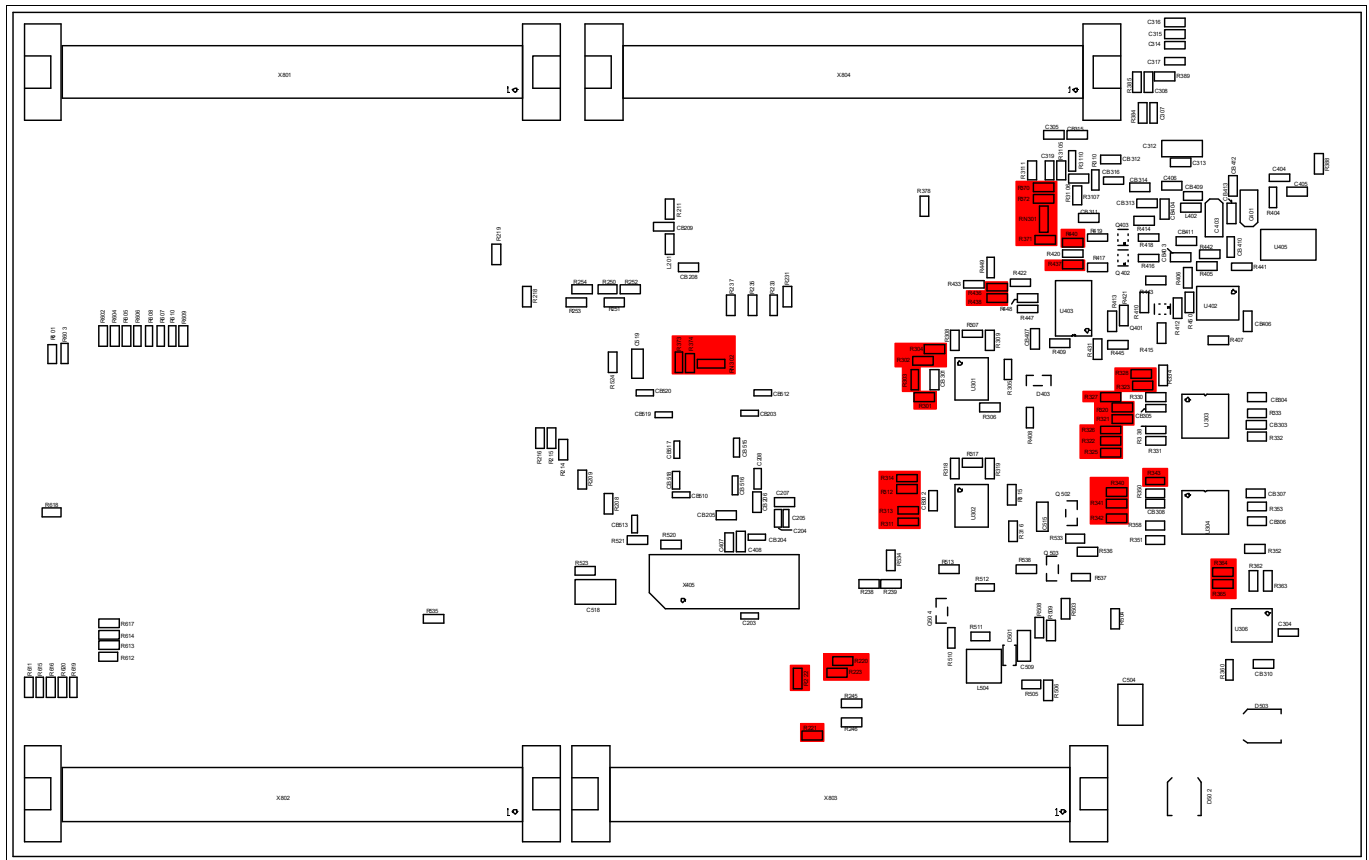

Figure 4-5 Location of peripheral resistors on Bottom Side

4.2.3 Resistors for MMIC

Table 4-4 Resistors for MMIC (default assembly in brackets)

Component	Description
R601	Connect P02.2 to MMIC0_IO8 (assembled)
R602	Connect P00.9 to MMIC0_IO7 (assembled)
R603	Connect P00.8 to MMIC0_IO6 (assembled)
R604	Connect /ESR0 to MMIC0_RESET_N (assembled)
R605	Connect P00.7 to MMIC0_IO5 (assembled)
R606	Connect P00.6 to MMIC0_IO4 (assembled)
R607	Connect P00.3 to MMIC0_IO2 (assembled)
R608	Connect P21.2 to MMIC0_OK (assembled)
R609	Connect P00.4 to MMIC0_IO3 (assembled)
R610	Connect P10.3 to MMIC0_IO1 (assembled)
R611	Connect P10.6 to MMIC1_IO8 (assembled)
R612	Connect P10.5 to MMIC1_IO7 (assembled)
R613	Connect P02.3 to MMIC1_IO6 (assembled)
R614	Connect /ESR0 to MMIC1_RESET_N (assembled)
R615	Connect P00.12 to MMIC1_IO5 (assembled)

### TriBoard Configuration

**Table 4-4 Resistors for MMIC (default assembly in brackets) (continued)**

Component	Description
R616	Connect P00.11 to MMIC1_IO4 (assembled)
R617	Connect P00.10 to MMIC1_IO2 (assembled)
R618	Connect P21.2 to MMIC1_OK (assembled)
R619	Connect P10.7 to MMIC1_IO3 (assembled)
R620	Connect P10.8 to MMIC1_IO1 (assembled)

*Note: All resistors are red marked in the following figures*

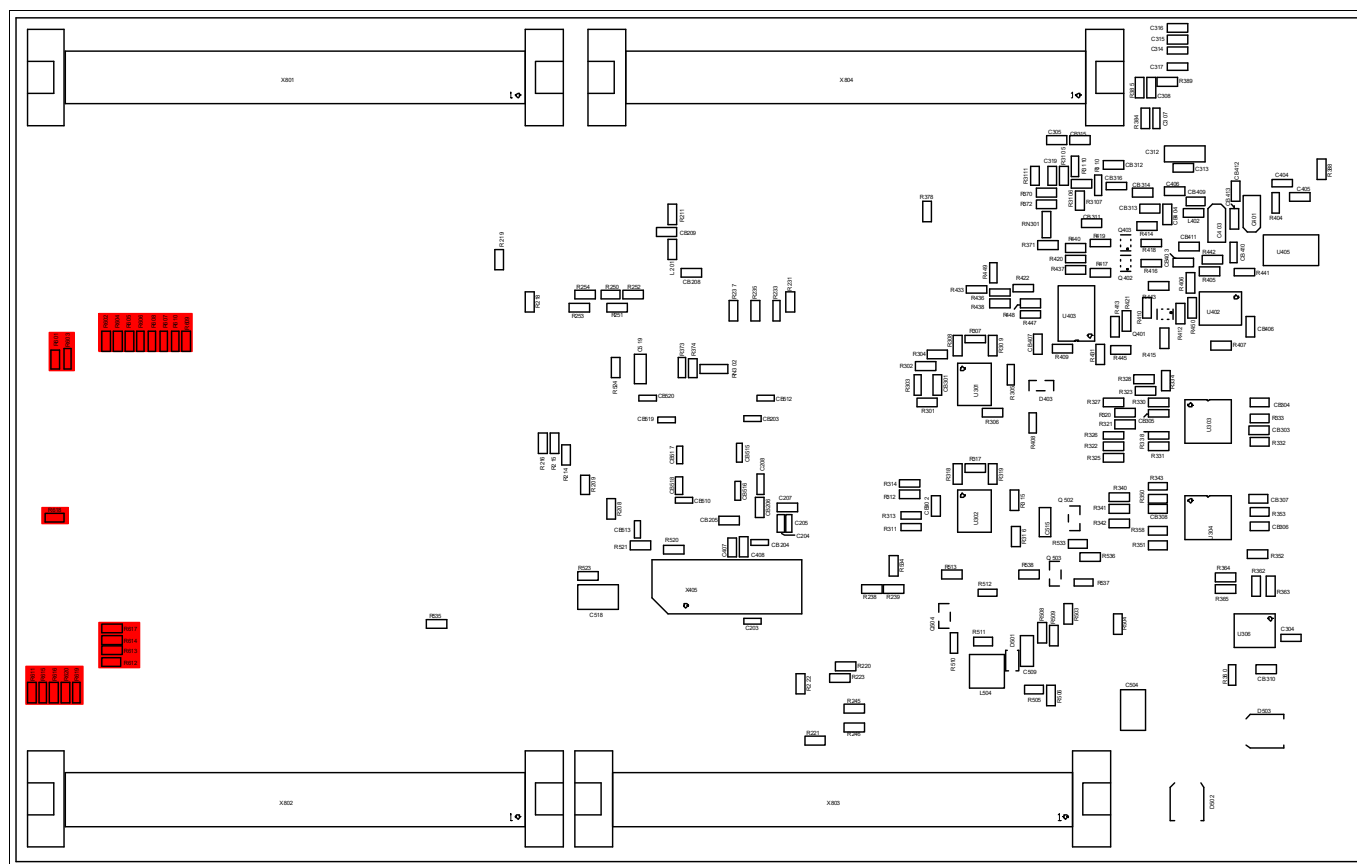

**Figure 4-6 Location of MMIC resistors**

**Signal (on board used) Description**

## 5 Signal (on board used) Description

For more information about the signals please see the user manual/datasheet for TC3X7 ADAS and/or the schematics of the board.

All not mentioned signals are not used on the board and can be used outside. Optional marked signals are used only if they are connected (default is that they are not used on the board).

### 5.1 Power Signals

**Table 5-1 Power Signals**

Short name	Description
VCC_IN	Supply Input (3,5V...40V)
VIN	Input Voltage of Power Supply Device
GND	Ground
+3V3	Microcontroller Supply Voltage (VEXT and VDDP3) and Peripherals Supply
+5V	Communication Supply Voltage (CAN, FLEXRAY) and ADC Supply Voltage
VDD	Core Supply Voltage (1,25V)
VDDP3	Flash Power Supply Voltage (3,3V)
VFLEX	Flexport Supply Voltage (3,3V)
VEXTOSC	Oscillator Port Supply Voltage (3,3V)
VDDOSC	Oscillator Core Supply Voltage (1,25V)
VSSOSC	Oscillator Ground
VDDM	ADC Analog Part Supply Voltage (5V or 3,3V selectable via 0R resistors)
VAREF1	ADC Reference Voltage 1 (VDDM)
VAREF2	ADC Reference Voltage 2 (VDDM)
VDD_USB	Supply Voltage from USB (5V)
VDD_FT	Supply Voltage FT2232HL device (3,3V)

### 5.2 Reset Signals

**Table 5-2 Reset Signals**

Short name	Description
/PORST	Power On Reset
/DBG_PORST	Power On Reset from debug connectors
/ESR0	External Service Request 0 (Hardware Reset)
/ESR1	External Service Request 1 (Non Maskable Interrupt)

---

**Signal (on board used) Description**

### 5.3 Config Signals

**Table 5-3 Config Signals**

Short name	Description
P14.5	HWCFG1 (EVR33OFF / EVR33ON)
P14.2	HWCFG2 (EVRCOFF / EVRCON)
P14.4	HWCFG6 (Pins in tristate / Pins with pull-up)
P14.3	HWCFG3 (Boot from pins / Boot from Flash BMI)
P10.5	HWCFG4 (see boot configuration <a href="#">Table 4-1</a> )
P10.6	HWCFG5 (see boot configuration <a href="#">Table 4-1</a> )

### 5.4 Clock Signals

**Table 5-4 Clock Signals**

Short name	Description
XTAL1	Crystal Oscillator Input
XTAL2	Crystal Oscillator Output

### 5.5 Debug Signals

**Table 5-5 Debug Signals**

Short name	Description
/TRST	Test Reset
DAP0	Device Access Port Line 0 / Test Data Clock (TCK)
DAP1	Device Access Port Line 1 / Test Data Select (TMS)
DAP2	Device Access Port Line 2 / Test Data Output (TDO)
DAPE0	Device Access Port Line 0 (Emulation part)
DAPE1	Device Access Port Line 1 (Emulation part)
DAPE2	Device Access Port Line 2 (Emulation part)
P21.6	Test Data Input (TDI)
DAP0_A	DAP0 / DAPE0 / TCK from debug connectors
DAP1_A	DAP1 / DAPE1 / TMS from debug connectors
P21.7	DAP2 / DAPE2 / TDO from debug connectors
P20.2	Test Mode Select Input
P20.1	TriCore Breakpoint Input
P20.0	TriCore Breakpoint Output
AGBT_CLK_P/_N	AGBT Clock Input
AGBT_TX0_P/_N	AGBT Transmit Output
AGBT_ERR	AGBT Error Output



Signal (on board used) Description

5.6 Peripheral Signals

Table 5-6 Peripheral Signals

Short name	Description
P14.1	ASCLIN0 Receive Input A CAN01 Receive Input B (optional)
P14.0	ASCLIN0 Transmit Output CAN01 Transmit Output (optional)
P15.3	ASCLIN0 Receive Input B (optional)
P15.2	ASCLIN0 Transmit Output (optional)
P15.1	ASCLIN1 Receive Input A
P15.0	ASCLIN1 Transmit Output
P15.4	I2C0 Serial Clock
P15.5	I2C0 Serial Data Input C und Output
P20.7	CAN00 Receive Input B
P20.8	CAN00 Transmit Output
P23.0	CAN10 Receive Input C
P23.1	CAN10 Transmit Output
P00.1	CAN10 Receive Input A (optional)
P00.0	CAN10 Transmit Output (optional)
P14.10	E-Ray Channel A Transmit Data Output
P14.9	E-Ray Channel A Transmit Data Output enable
P14.8	E-Ray Channel A Receive Data Input 0
P32.3	E-Ray Channel A Enable Output
P32.2	E-Ray Channel A Error Input
P14.5	E-Ray Channel B Transmit Data Output
P14.6	E-Ray Channel B Transmit Data Output enable
P14.7	E-Ray Channel B Receive Data Input 0
P20.10	E-Ray Channel B Enable Output
P20.9	E-Ray Channel B Error Input
P02.0	E-Ray Channel A Transmit Data Output (optional)
P02.4	E-Ray Channel A Transmit Data Output enable (optional)
P02.1	E-Ray Channel A Receive Data Input 2 (optional)
P10.2	E-Ray Channel A Enable Output (optional)
P10.1	E-Ray Channel A Error Input (optional)
TXD3	Ethernet TXD3 Output (P11.0)
TXD2	Ethernet TXD2 Output (P11.1)
TXD1	Ethernet TXD1 Output (P11.2)
TXD0	Ethernet TXD0 Output (P11.3)
TXCLK	Ethernet TXCLK Output (P11.4)

## Signal (on board used) Description

Table 5-6 Peripheral Signals (continued)

Short name	Description
REFCLK	Ethernet GREFCLK Input (P11.5)
TCTL	Ethernet TCTL Output (P11.6)
RXD3	Ethernet RXD3 Input A (P11.7)
RXD2	Ethernet RXD2 Input A (P11.8)
RXD1	Ethernet RXD1 Input A (P11.9)
RXD0	Ethernet RXD0 Input A (P11.10)
RCTL	Ethernet RCTL Input A (P11.11)
RXCLK	Ethernet RXCLK Input A (P11.12)
P12.0	Ethernet Management Data Clock Output (MDC)
P12.1	Ethernet Management Data Input/Output (MDIO)
P15.8	Ethernet MD Interrupt Input (optional)
P14.2	QSPI2 Slave Select Output 1 for SCS of TLF30682
P15.3	QSPI2 Master Clock Output for SCL of TLF30682
P15.6	QSPI2 Master Transmit Output for SDI of TLF30682
P15.7	QSPI2 Master Receive Input B for SDO from TLF30682
P14.3	Output for Watchdog Input of TLF30682
P33.8	Connected to TM2 (pin 44) of TLF30682 (invalid connection)
P33.9	Connected to NC (pin 2) of TLF30682 (invalid connection)
P20.0	HSCT System Clock
P21.2	HSCT Data Negative Input
P21.3	HSCT Data Positive Input
P21.4	HSCT Data Negative Output
P21.5	HSCT Data Positive Output
P20[11...14]	On board LED's
P33[4...7]	On board LED's

## 5.7 MMIC / RIF Signals

Table 5-7 MMIC / RIF Signals

Short name	Description
RIF0_D1_N / P50.0	RIF0 Data Bit Channel 1 Negative Input
RIF0_D1_P / P50.1	RIF0 Data Bit Channel 1 Positive Input
RIF0_D2_N / P50.2	RIF0 Data Bit Channel 2 Negative Input
RIF0_D2_P / P50.3	RIF0 Data Bit Channel 2 Positive Input
RIF0_D3_N / P50.9	RIF0 Data Bit Channel 3 Negative Input
RIF0_D3_P / P50.8	RIF0 Data Bit Channel 3 Positive Input
RIF0_D4_N / P50.11	RIF0 Data Bit Channel 4 Negative Input
RIF0_D4_P / P50.10	RIF0 Data Bit Channel 4 Positive Input

**Signal (on board used) Description**

**Table 5-7 MMIC / RIF Signals** (continued)

<b>Short name</b>	<b>Description</b>
RIF0_CLK_N / P50.4	RIF0 Serial Clock Negative Input
RIF0_CLK_P / P50.5	RIF0 Serial Clock Positive Input
RIF0_FR_N / P50.7	RIF0 Frameclock Negative Input
RIF0_FR_P / P50.6	RIF0 Frameclock Positive Input
P02.8	QSPI3 Slave Select Output 5
P00.2	QSPI3 Slave Select Output 4
P00.5	QSPI3 Slave Select Output 3
P02.7	QSPI3 Master Clock Output
P02.6	QSPI3 Master Transmit Output
P02.5	QSPI3 Master Receive Input A
RIF1_D1_N / P51.0	RIF1 Data Bit Channel 1 Negative Input
RIF1_D1_P / P51.1	RIF1 Data Bit Channel 1 Positive Input
RIF1_D2_N / P51.2	RIF1 Data Bit Channel 2 Negative Input
RIF1_D2_P / P51.3	RIF1 Data Bit Channel 2 Positive Input
RIF1_D3_N / P51.9	RIF1 Data Bit Channel 3 Negative Input
RIF1_D3_P / P51.8	RIF1 Data Bit Channel 3 Positive Input
RIF1_D4_N / P51.11	RIF1 Data Bit Channel 4 Negative Input
RIF1_D4_P / P51.10	RIF1 Data Bit Channel 4 Positive Input
RIF1_CLK_N / P51.4	RIF1 Serial Clock Negative Input
RIF1_CLK_P / P51.5	RIF1 Serial Clock Positive Input
RIF1_FR_N / P51.7	RIF1 Frameclock Negative Input
RIF1_FR_P / P51.6	RIF1 Frameclock Positive Input
P10.0	QSPI1 Slave Select Output 10
P33.5	QSPI1 Slave Select Output 7
P20.13	QSPI1 Slave Select Output 2
P10.2	QSPI1 Master Clock Output
P10.4	QSPI1 Master Transmit Output
P10.1	QSPI1 Master Receive Input A

**Connector Pin Assignment**

## 6 Connector Pin Assignment

The TriBoard will be shipped with four male (plug) connectors on top layer and four female (socket) connectors on bottom layer. The default connectors are 80-pol. Board to Board connectors from Samtec:

<http://www.samtec.com>

Plug:

FTSH-140-02-L-DV-ES-A

Socket:

FLE-140-01-G-DV-A

### 6.1 On Board only used signals

Following port pins are only used on board and are not connected to any connector also not via resistor:

**Table 6-1 On Board only used Signals**

Short name	Description
P32.0	Used as VGATE1N for EVRC
P32.1	Used as VGATE1P for EVRC
P14.2	Used as HWCFG2 and Slave Select Output (SLSO21) to TLF30682
P14.4	Used as HWCFG6
P14.5	Used as HWCFG1 and E-Ray Channel B Transmit Data Output
P14.6	Used as E-Ray Channel B Transmit Data Output enable
P11.0	Used as Gigabit Transmit Data Output 3 for RGMII
P11.1	Used as Gigabit Transmit Data Output 2 for RGMII
P11.2	Used as Gigabit Transmit Data Output 1 for RGMII
P11.3	Used as Gigabit Transmit Data Output 0 for RGMII
P11.4	Used as Gigabit Transmit Clock Output for RGMII
P11.5	Used as Gigabit Reference Clock input for RGMII (125 MHz high precision)
P11.6	Used as Gigabit Transmit Control Output for RGMII
P11.7	Used as Gigabit Receive Data Input 3 for RGMII
P11.8	Used as Gigabit Receive Data Input 2 for RGMII
P11.9	Used as Gigabit Receive Data Input 1 for RGMII
P11.10	Used as Gigabit Receive Data Input 0 for RGMII
P11.11	Used as Gigabit Receive Data Control Input for RGMII
P11.12	Used as Gigabit Receive Clock Input for RGMII

Connector Pin Assignment

6.2 TC397 ADAS Connector / Top View

BUS EXPANSION (X701,X801)			PERIPHERALS (X702,X802)			
GND	1	2	GND	1	2	GND
GND	3	4	GND	3	4	GND
	5	6	P21.6	5	6	VCC_IN
	7	8	P21.7	7	8	VCC_IN
P50.0	9	10	P51.0	9	10	P22.4
P50.1	11	12	P51.1	11	12	P22.5
P50.2	13	14	P51.2	13	14	P22.6
P50.3	15	16	P51.3	15	16	/ESR1
P50.4	17	18	P51.4	17	18	P22.7
P50.5	19	20	P51.5	19	20	GND
P50.6	21	22	P51.6	21	22	/PORST
P50.7	23	24	P51.7	23	24	P10.5
P50.8	25	26	P51.8	25	26	P10.4
P50.9	27	28	P51.9	27	28	P10.2
P50.10	29	30	P51.10	29	30	
P50.11	31	32	P51.11	31	32	
	33	34		33	34	
	35	36		35	36	
	37	38		37	38	P20.9
	39	40		39	40	P20.13
	41	42		41	42	P33.5
	43	44		43	44	P20.3
	45	46		45	46	P00.0
	47	48		47	48	P00.1
	49	50	P21.2	49	50	GND
	51	52	P21.3	51	52	XTAL1
	53	54	P21.4	53	54	XTAL2
	55	56	P21.5	55	56	P15.3
	57	58		57	58	P15.2
	59	60		59	60	P14.1
	61	62		61	62	P14.0
	63	64		63	64	P20.11
	65	66		65	66	P20.14
	67	68		67	68	P20.12
	69	70		69	70	P20.7
	71	72	P20.0	71	72	P15.8
	73	74		73	74	P10.7
	75	76		75	76	
	77	78		77	78	+3V3
P21.0	79	80	P21.1	79	80	+3V3

Figure 6-1 Connector for TC397 ADAS - Pinout (Part I, Top View)

Connector Pin Assignment

ADC (X703, X803)			GTM / PORTS (X704,X804)			
GND	1	2	GND	1	2	GND
GND	3	4	GND	3	4	GND
AN0	5	6	AN16	5	6	P11.14
AN1	7	8	AN17	7	8	P11.15
AN2	9	10	AN18	9	10	
AN3	11	12	AN19	11	12	
AN4	13	14	AN20	13	14	
AN5	15	16	AN21	15	16	
AN6	17	18	AN22	17	18	P14.7
AN7	19	20	AN23	19	20	P14.8
AN8	21	22	AN24	21	22	P14.9
AN9	23	24	AN25	23	24	P14.10
AN10	25	26		25	26	P15.6
AN11	27	28		27	28	P15.7
AN12	29	30		29	30	P20.1
AN13	31	32	P10.0	31	32	
AN14	33	34	P10.1	33	34	
AN15	35	36	P10.6	35	36	P23.0
GND	37	38	P12.0	37	38	P23.2
VDDM	39	40	P12.1	39	40	P23.5
GND	41	42		41	42	P23.6
GND	43	44		43	44	P23.7
	45	46		45	46	
	47	48		47	48	
	49	50		49	50	P32.2
	51	52		51	52	P32.3
AN36	53	54	AN44	53	54	P32.5
AN37	55	56	AN45	55	56	P33.8
AN38	57	58	AN46	57	58	P33.9
AN39	59	60	AN47	59	60	P33.10
GND	61	62	GND	61	62	P33.13
P33.3	63	64	P33.6	63	64	P33.14
P33.2	65	66	P33.0	65	66	P33.15
P33.1	67	68	P33.4	67	68	P32.6
+3V3	69	70	+3V3	69	70	P32.7
P02.6	71	72	P00.6	71	72	P34.4
P02.7	73	74	P00.7	73	74	P34.5
P02.8	75	76	P00.8	75	76	
P33.7	77	78	P14.3	77	78	+3V3
P33.11	79	80	P33.12	79	80	+3V3

Figure 6-2 Connector for TC397 ADAS - Pinout (Part II, Top View)

Connector Pin Assignment

6.3 TC357/TC3A7 Connector / Top View

BUS EXPANSION (X701,X801)			PERIPHERALS (X702,X802)			
GND	1	2	GND	1	2	GND
GND	3	4	GND	3	4	GND
	5	6	P21.6	5	6	VCC_IN
	7	8	P21.7	7	8	VCC_IN
P50.0	9	10	P51.0	9	10	P22.4
P50.1	11	12	P51.1	11	12	P22.5
P50.2	13	14	P51.2	13	14	
P50.3	15	16	P51.3	15	16	/ESR1
P50.4	17	18	P51.4	17	18	
P50.5	19	20	P51.5	19	20	GND
P50.6	21	22	P51.6	21	22	/PORST
P50.7	23	24	P51.7	23	24	P10.5
P50.8	25	26	P51.8	25	26	P10.4
P50.9	27	28	P51.9	27	28	P10.2
P50.10	29	30	P51.10	29	30	
P50.11	31	32	P51.11	31	32	
	33	34		33	34	
	35	36		35	36	
	37	38		37	38	P20.9
	39	40		39	40	P20.13
	41	42		41	42	P33.5
	43	44		43	44	P20.3
	45	46		45	46	P00.0
	47	48		47	48	P00.1
	49	50	P21.2	49	50	GND
	51	52	P21.3	51	52	XTAL1
	53	54	P21.4	53	54	XTAL2
	55	56	P21.5	55	56	P15.3
	57	58		57	58	P15.2
	59	60		59	60	P14.1
	61	62		61	62	P14.0
	63	64		63	64	P20.11
	65	66		65	66	P20.14
	67	68		67	68	P20.12
	69	70		69	70	P20.7
	71	72	P20.0	71	72	P15.8
	73	74		73	74	P10.7
	75	76		75	76	
	77	78		77	78	+3V3
P21.0	79	80	P21.1	79	80	+3V3

Figure 6-3 Connector for TC357/TC3A7 - Pinout (Part I, Top View)

Connector Pin Assignment

ADC (X703, X803)			PORTS (X704,X804)			
GND	1	2	GND	1	2	GND
GND	3	4	GND	3	4	GND
AN0	5	6	P00.9	5	6	P11.14
AN1	7	8	P00.10	7	8	P11.15
AN2	9	10	P02.0	9	10	
AN3	11	12	P02.1	11	12	
AN4	13	14	P02.2	13	14	
AN5	15	16	P02.3	15	16	
AN6	17	18	P02.4	17	18	P14.7
AN7	19	20	P02.5	19	20	P14.8
AN8	21	22		21	22	P14.9
AN9	23	24		23	24	P14.10
AN10	25	26		25	26	P15.6
AN11	27	28		27	28	P15.7
AN12	29	30		29	30	P20.1
AN13	31	32	P10.0	31	32	
AN14	33	34	P10.1	33	34	
AN15	35	36	P10.6	35	36	P23.0
GND	37	38	P12.0	37	38	P23.2
VDDM	39	40	P12.1	39	40	P23.5
GND	41	42		41	42	
GND	43	44		43	44	
	45	46		45	46	
	47	48		47	48	
	49	50		49	50	P32.2
	51	52		51	52	P32.3
	53	54		53	54	P32.5
	55	56		55	56	P33.8
	57	58		57	58	P33.9
	59	60		59	60	P33.10
GND	61	62	GND	61	62	P33.13
P33.3	63	64	P33.6	63	64	
P33.2	65	66	P33.0	65	66	
P33.1	67	68	P33.4	67	68	P32.6
+3V3	69	70	+3V3	69	70	
P02.6	71	72	P00.6	71	72	
P02.7	73	74	P00.7	73	74	
P02.8	75	76	P00.8	75	76	
P33.7	77	78	P14.3	77	78	+3V3
P33.11	79	80	P33.12	79	80	+3V3

Figure 6-4 Connector for TC357/TC3A7 - Pinout (Part II, Top View)



Connector Pin Assignment

6.4 TC337 ADAS Connector / Top View

BUS EXPANSION (X701,X801)			PERIPHERALS (X702,X802)			
GND	1	2	GND	1	2	GND
GND	3	4	GND	3	4	GND
	5	6	P21.6	5	6	VCC_IN
	7	8	P21.7	7	8	VCC_IN
P50.0	9	10		9	10	P22.4
P50.1	11	12		11	12	P22.5
P50.2	13	14		13	14	
P50.3	15	16		15	16	/ESR1
P50.4	17	18		17	18	
P50.5	19	20		19	20	GND
P50.6	21	22		21	22	/PORST
P50.7	23	24		23	24	P10.5
P50.8	25	26		25	26	P10.4
P50.9	27	28		27	28	P10.2
P50.10	29	30		29	30	
P50.11	31	32		31	32	
	33	34		33	34	
	35	36		35	36	
	37	38		37	38	P20.9
	39	40		39	40	P20.13
	41	42		41	42	P33.5
	43	44		43	44	P20.3
	45	46		45	46	P00.0
	47	48		47	48	P00.1
	49	50	P21.2	49	50	GND
	51	52	P21.3	51	52	XTAL1
	53	54	P21.4	53	54	XTAL2
	55	56	P21.5	55	56	P15.3
	57	58		57	58	P15.2
	59	60		59	60	P14.1
	61	62		61	62	P14.0
	63	64		63	64	P20.11
	65	66		65	66	P20.14
	67	68		67	68	P20.12
	69	70		69	70	P20.7
	71	72	P20.0	71	72	P15.8
	73	74		73	74	P10.7
	75	76		75	76	
	77	78		77	78	+3V3
P21.0	79	80	P21.1	79	80	+3V3

Figure 6-5 Connector for TC337 ADAS - Pinout (Part I, Top View)

Connector Pin Assignment

ADC (X703, X803)			PORTS (X704,X804)			
GND	1	2	GND	1	2	GND
GND	3	4	GND	3	4	GND
AN0	5	6	AN16	5	6	P11.14
AN1	7	8	AN17	7	8	P11.15
AN2	9	10	AN18	9	10	
AN3	11	12	AN19	11	12	
AN4	13	14	AN20	13	14	
AN5	15	16	AN21	15	16	
AN6	17	18	AN22	17	18	P14.7
AN7	19	20	AN23	19	20	P14.8
AN8	21	22		21	22	P14.9
AN9	23	24		23	24	P14.10
AN10	25	26		25	26	P15.6
AN11	27	28		27	28	P15.7
AN12	29	30		29	30	P20.1
AN13	31	32		31	32	
AN14	33	34		33	34	
AN15	35	36		35	36	
GND	37	38	GND	37	38	
VDDM	39	40	VAREF1	39	40	P23.5
GND	41	42		41	42	
GND	43	44	GND	43	44	
	45	46		45	46	
	47	48		47	48	
	49	50		49	50	
	51	52		51	52	
	53	54		53	54	
	55	56		55	56	P33.8
	57	58		57	58	P33.9
	59	60		59	60	P33.10
GND	61	62	GND	61	62	P33.13
P33.3	63	64	P33.6	63	64	
P33.2	65	66	P33.0	65	66	
P33.1	67	68	P33.4	67	68	P11.13
+3V3	69	70	+3V3	69	70	P34.1
P02.6	71	72	P00.6	71	72	P34.2
P02.7	73	74	P00.7	73	74	P34.3
P02.8	75	76	P00.8	75	76	VFLEX
P33.7	77	78	P14.3	77	78	+3V3
P33.11	79	80	P33.12	79	80	+3V3

Figure 6-6 Connector for TC337 ADAS - Pinout (Part II, Top View)

Connector Pin Assignment

6.5 Power connector pinout

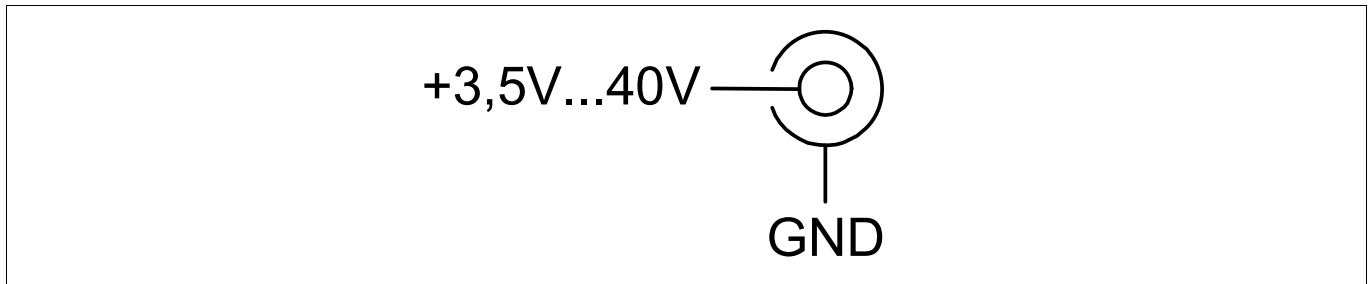

Figure 6-7 Power connector pinout (Roka 520 2550)

6.6 USB connector pinout

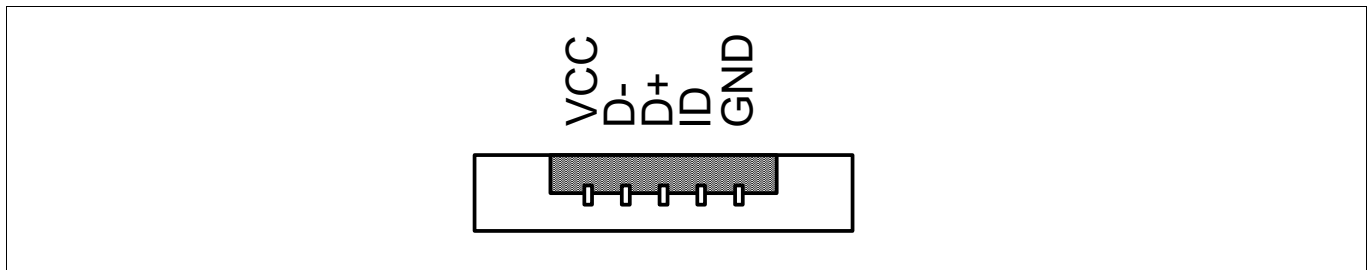

Figure 6-8 USB connector pinout (Micro USB B-type)

6.7 FlexRay™ (ERAY) connector pinout

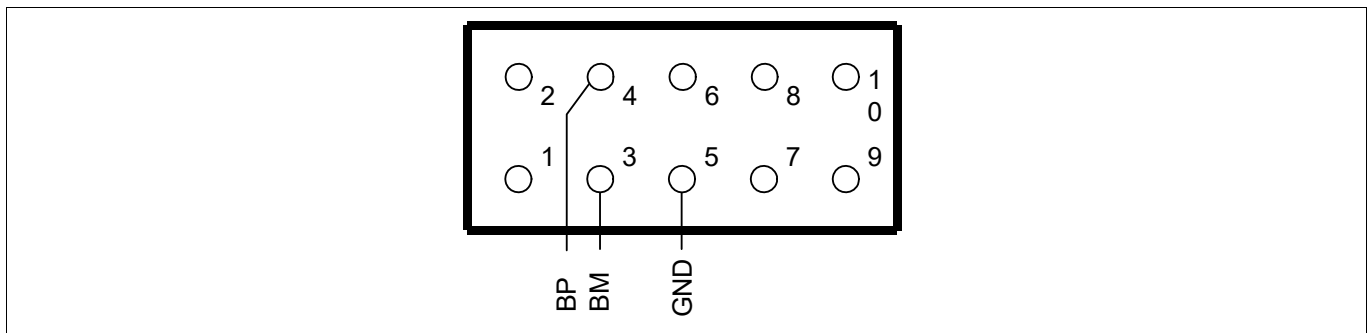

Figure 6-9 FlexRay™ (ERAY) connector pinout (IDC10)

6.8 CAN connector pinout

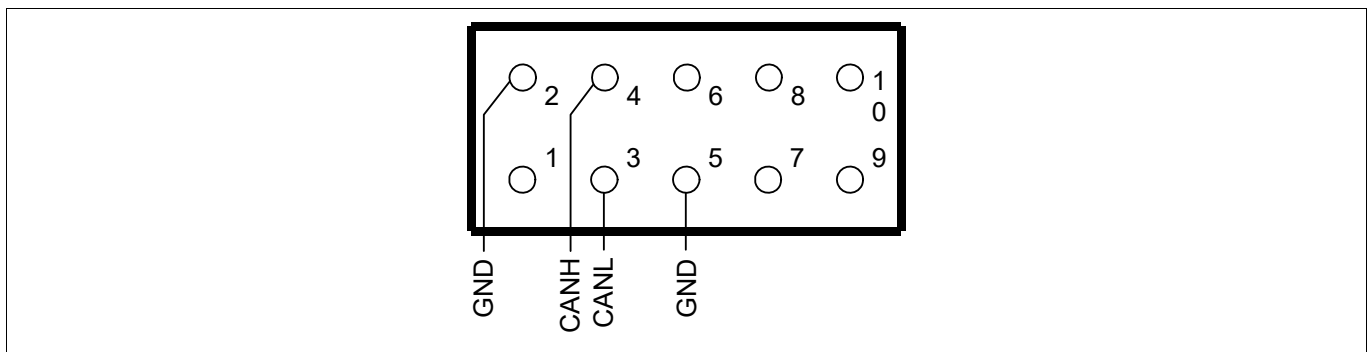

Figure 6-10 CAN connector pinout (IDC10)

Connector Pin Assignment

6.9 LIN connector pinout

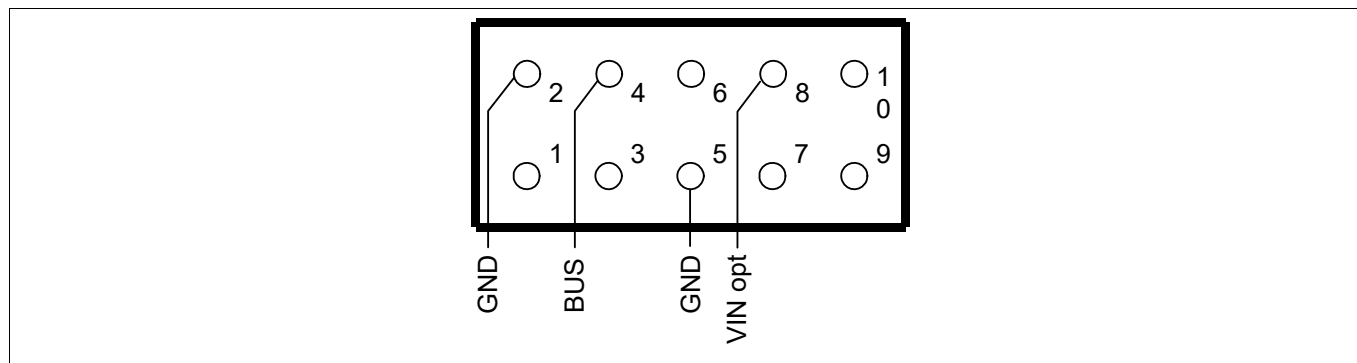

Figure 6-11 LIN connector pinout (IDC10)

6.10 HSCT connector pinout

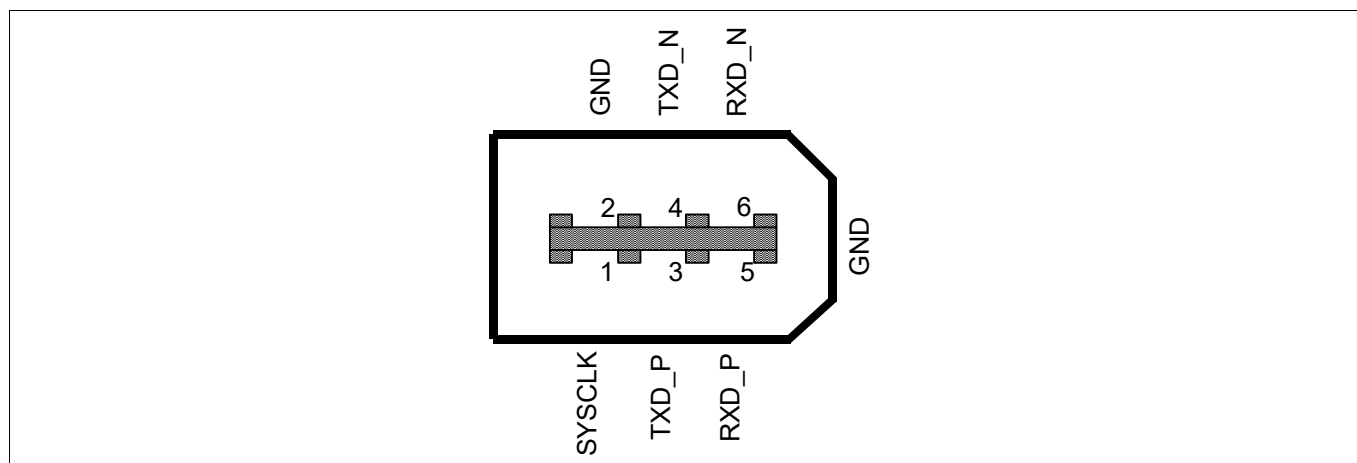

Figure 6-12 HSCT connector pinout (IEE1394 6-conductor)

6.11 Ethernet connector pinout

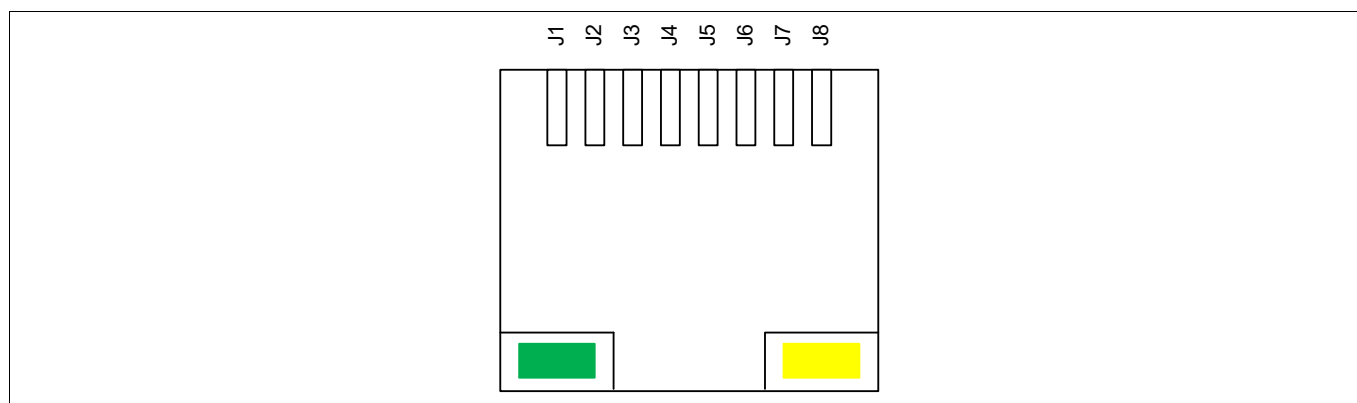

Figure 6-13 Ethernet connector pinout (RJ45)

Connector Pin Assignment

6.12 MMIC / RIF connector pinout

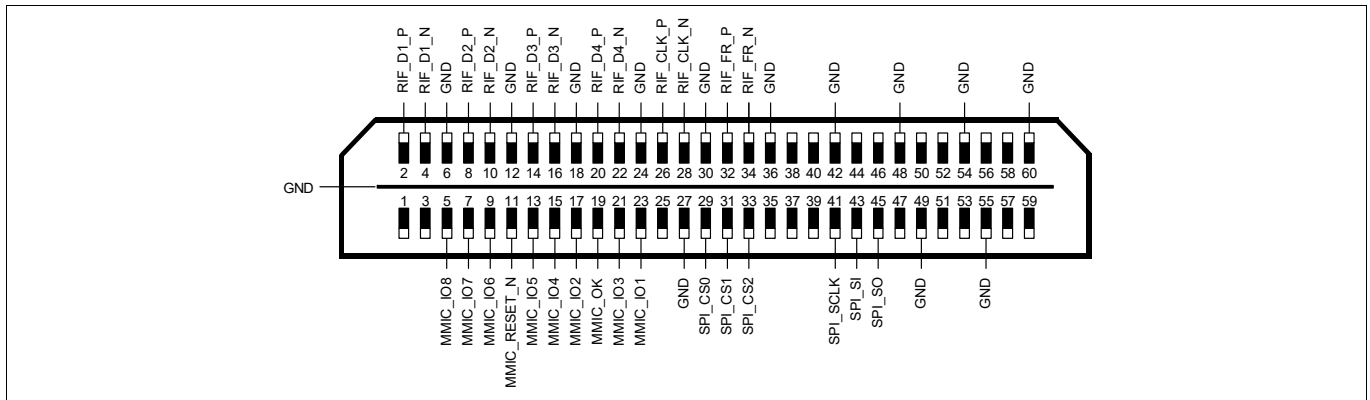

Figure 6-14 MMIC / RIF connector pinout (Samtec QSH-030)

6.13 OCDS1 connector pinout

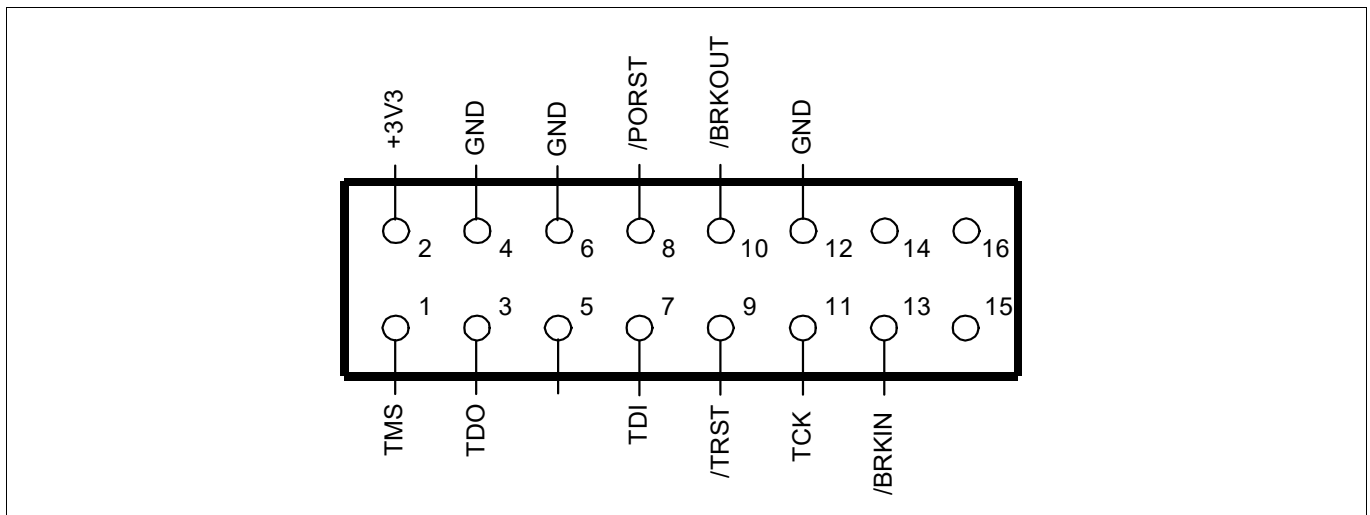

Figure 6-15 OCDS1 connector pinout (IDC16)

6.14 DAP connector pinout

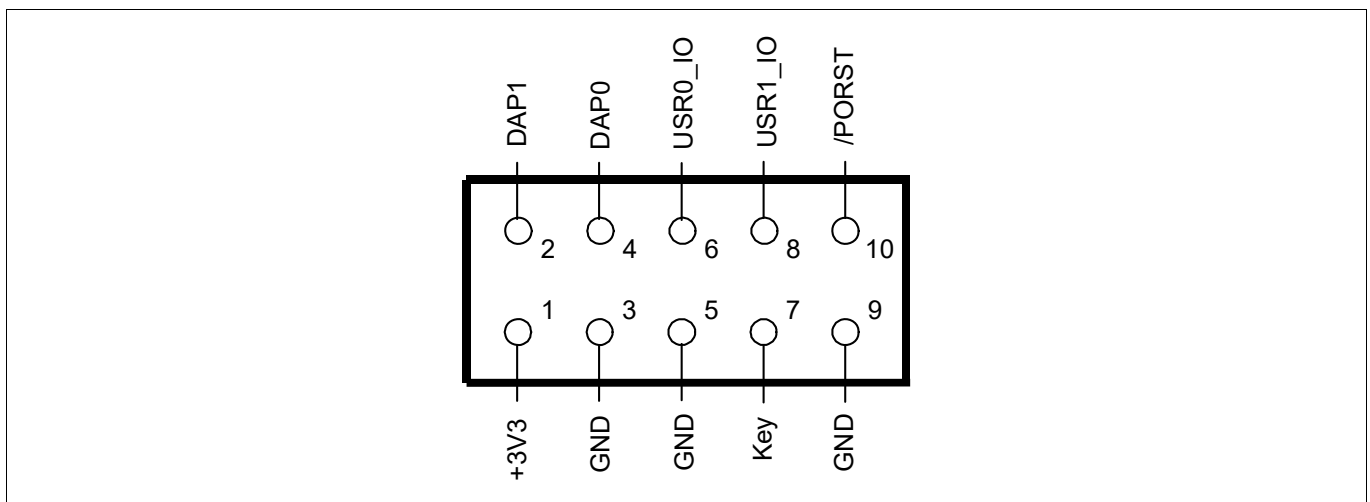

Figure 6-16 DAP connector pinout (Samtec FTSH10)

Connector Pin Assignment

6.15 ETK connector pinout

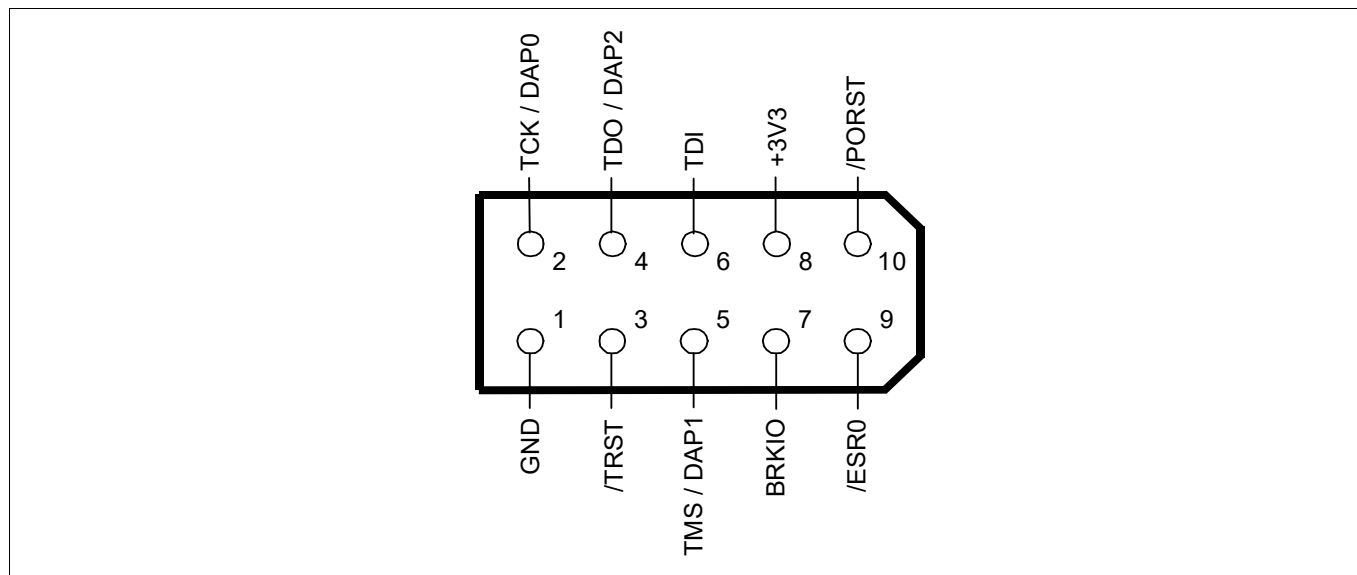

Figure 6-17 ETK connector pinout (Samtec TFM-105)

6.16 Ethernet miniWiggler power connector pinout

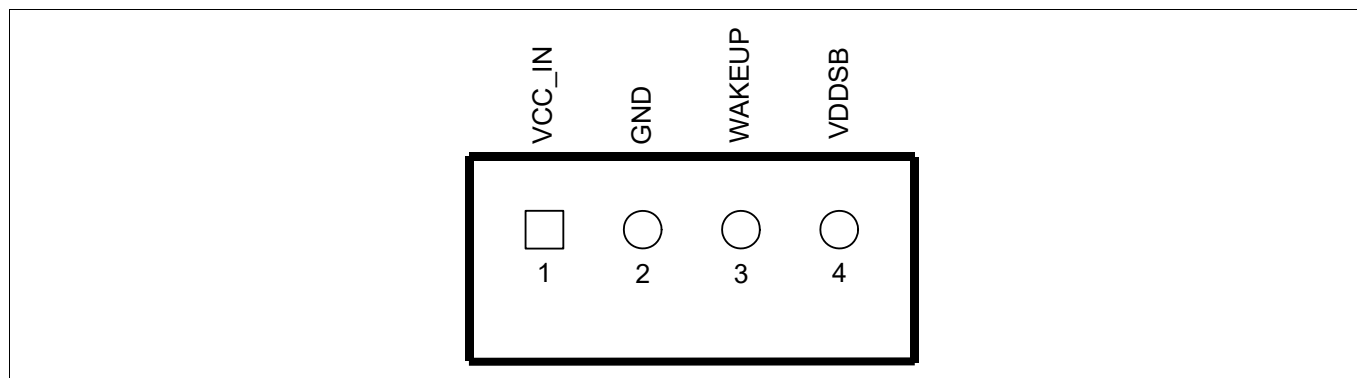

Figure 6-18 Ethernet miniWiggler connector pinout (JST B4B-PH)

Connector Pin Assignment

6.17 AGBT connector pinout

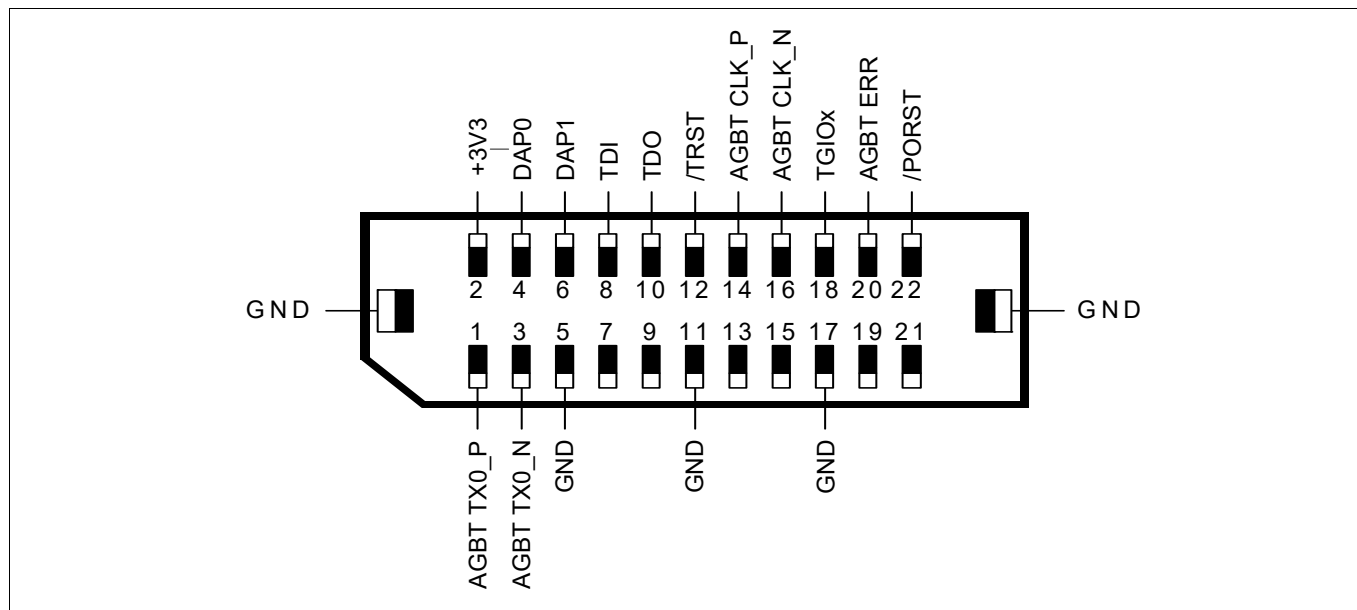

Figure 6-19 AGBT connector pinout (Samtec ASP-137969-01)

## 7 Schematic and Layout

### 7.1 Known problems

#### 7.1.1 Known problems (TriBoard TC3X7 ADAS TH V2.0)

No problems known.

#### 7.1.2 Known problems (TriBoard TC3X7 ADAS V2.0)

No problems known.

### 7.2 Schematic

#### 7.2.1 Hint about used TLF30682

Schematic was prepared for another device which will not be available. Therefore some names in the symbol of U501 don't match with the pin names of TLF30682 and should be changed (no functional issue if not other mentioned, only name change):

Pin 1 from AGS1 to AG5

Pin 2 from SSO to NC (don't connect any signal to this pin)

Pin 3 from AGS2 to AG6

Pin 5 from AG1 to NC (don't connect any signal to this pin)

Pin 17 from AG2 to AG1

Pin 18 from GST to AG2

Pin 30 from R3PG2 to R3PG1

Pin 32 from FRE to TM1

Pin 44 from ERR to TM2 (connect this pin directly to ground)



Schematic and Layout

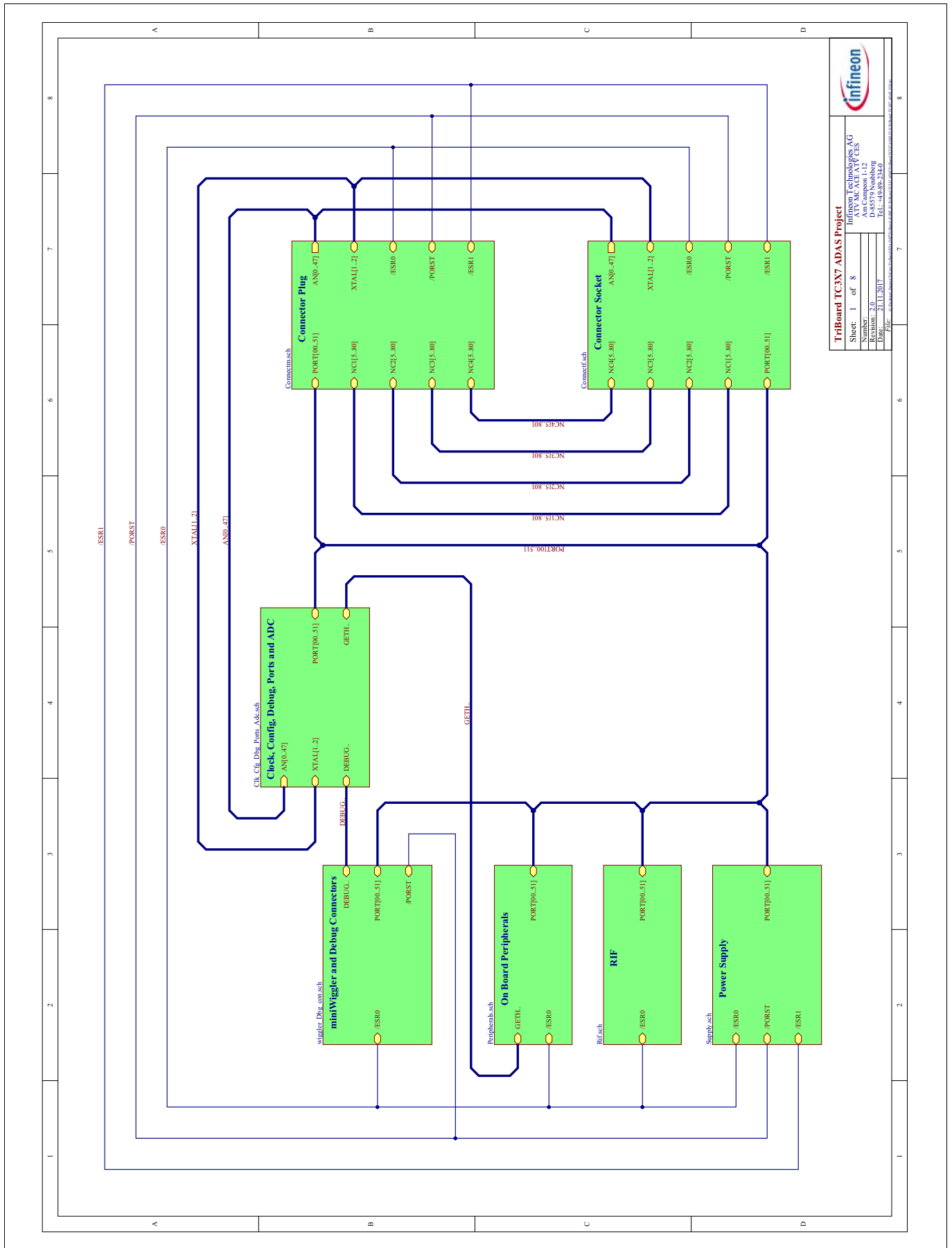
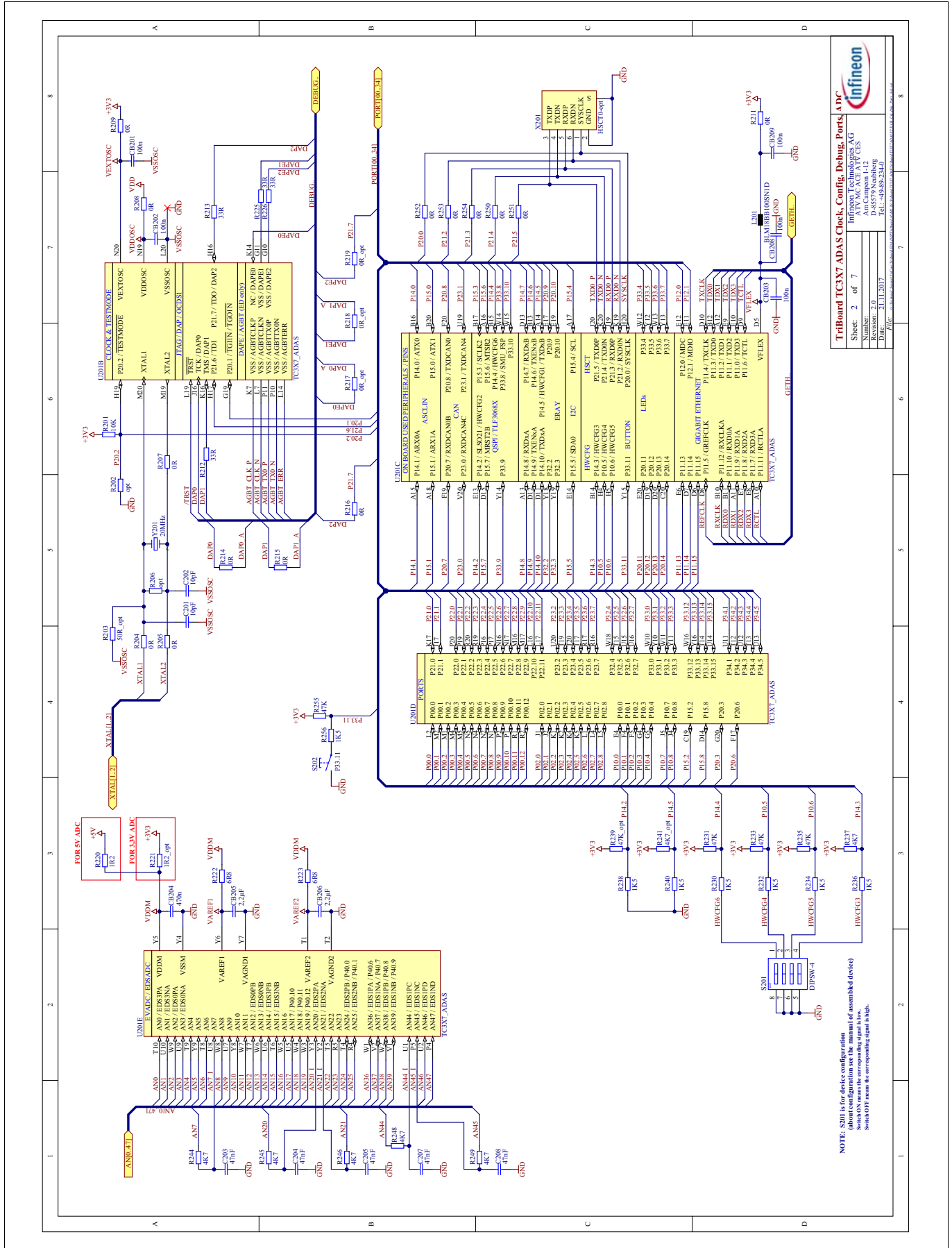

Figure 7-1 Schematic - Project

# TriBoard Manual TC3X7 ADAS

## Hardware: TriBoard TC3X7 ADAS TH V2.0 and TriBoard TC3X7 ADAS V2.0

### Schematic and Layout



# TriBoard Manual TC3X7 ADAS

## Hardware: TriBoard TC3X7 ADAS TH V2.0 and TriBoard TC3X7 ADAS V2.0



### Schematic and Layout

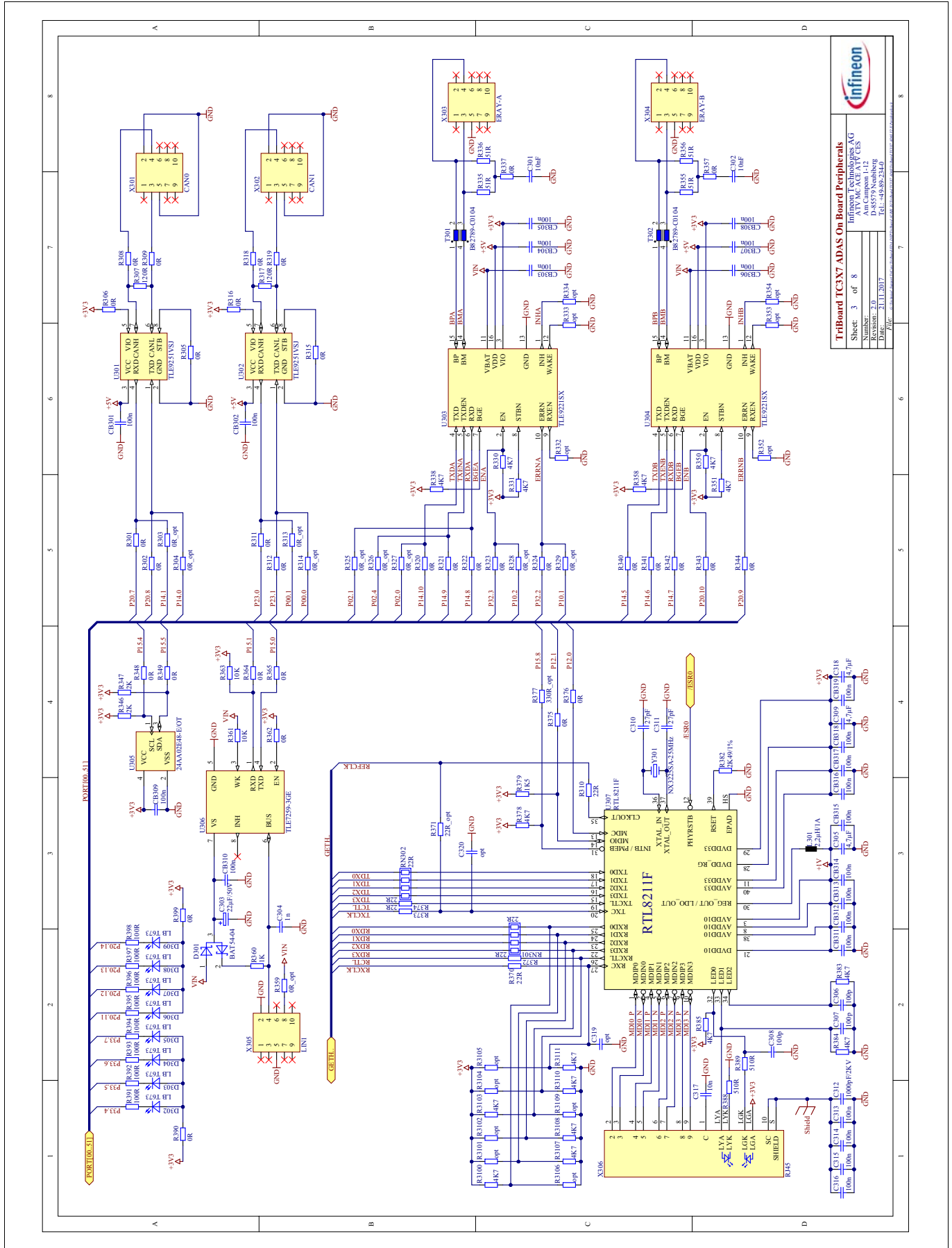

**Figure 7-3 Schematic - On Board Peripherals**

### Schematic and Layout

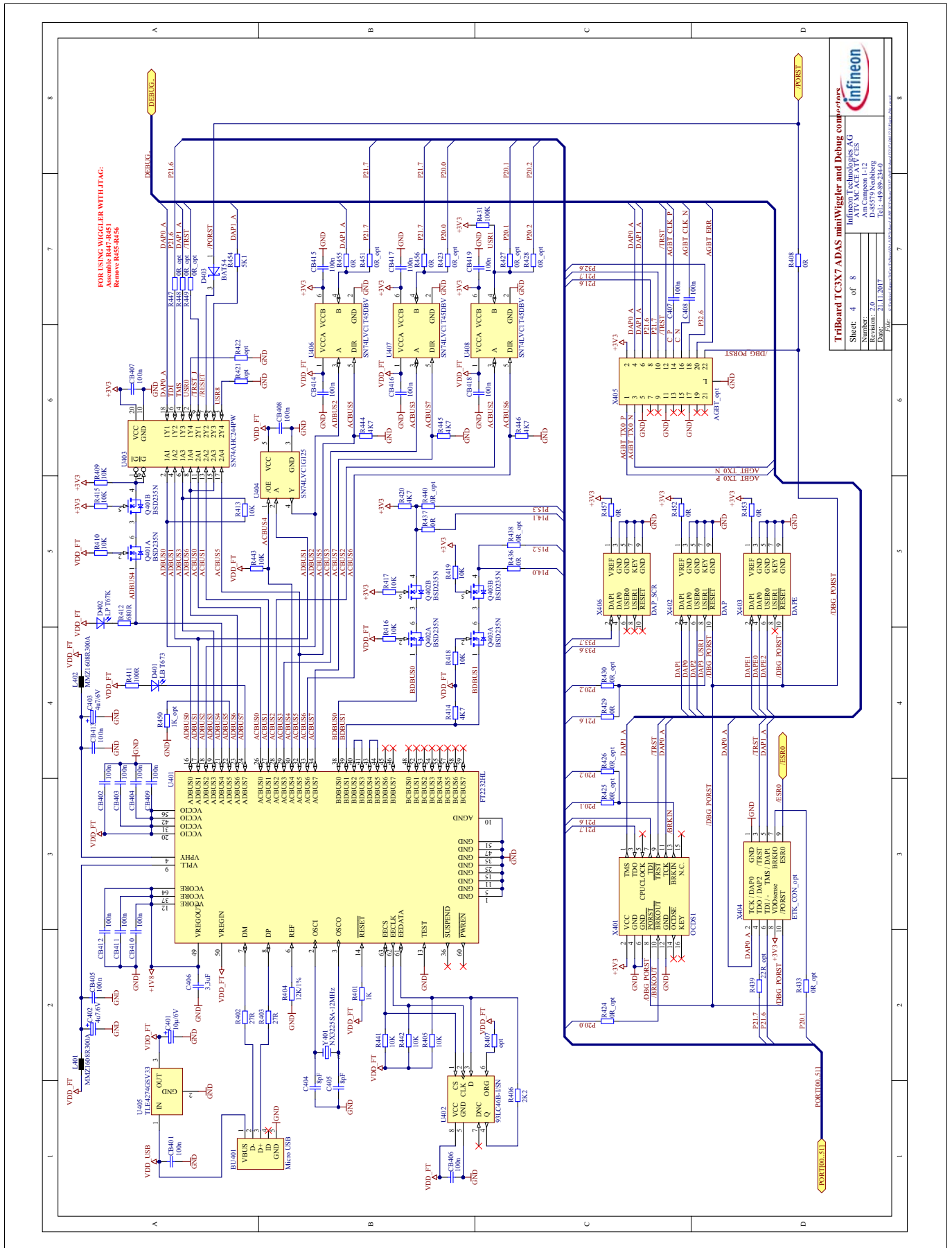

Figure 7-4 Schematic - miniWiggler JDS and Debug connectors

### Schematic and Layout

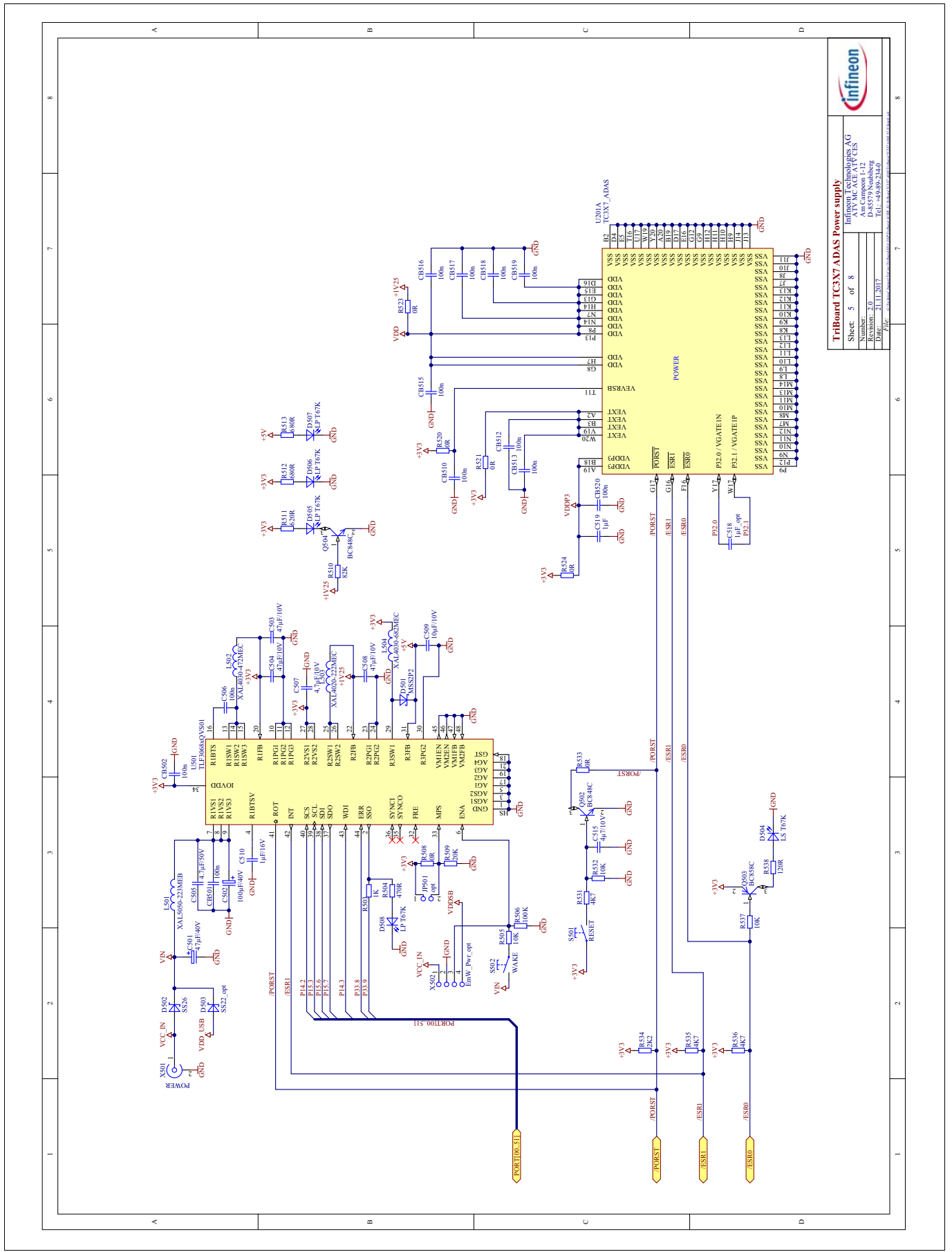

Figure 7-5 Schematic - Power Supply

Schematic and Layout

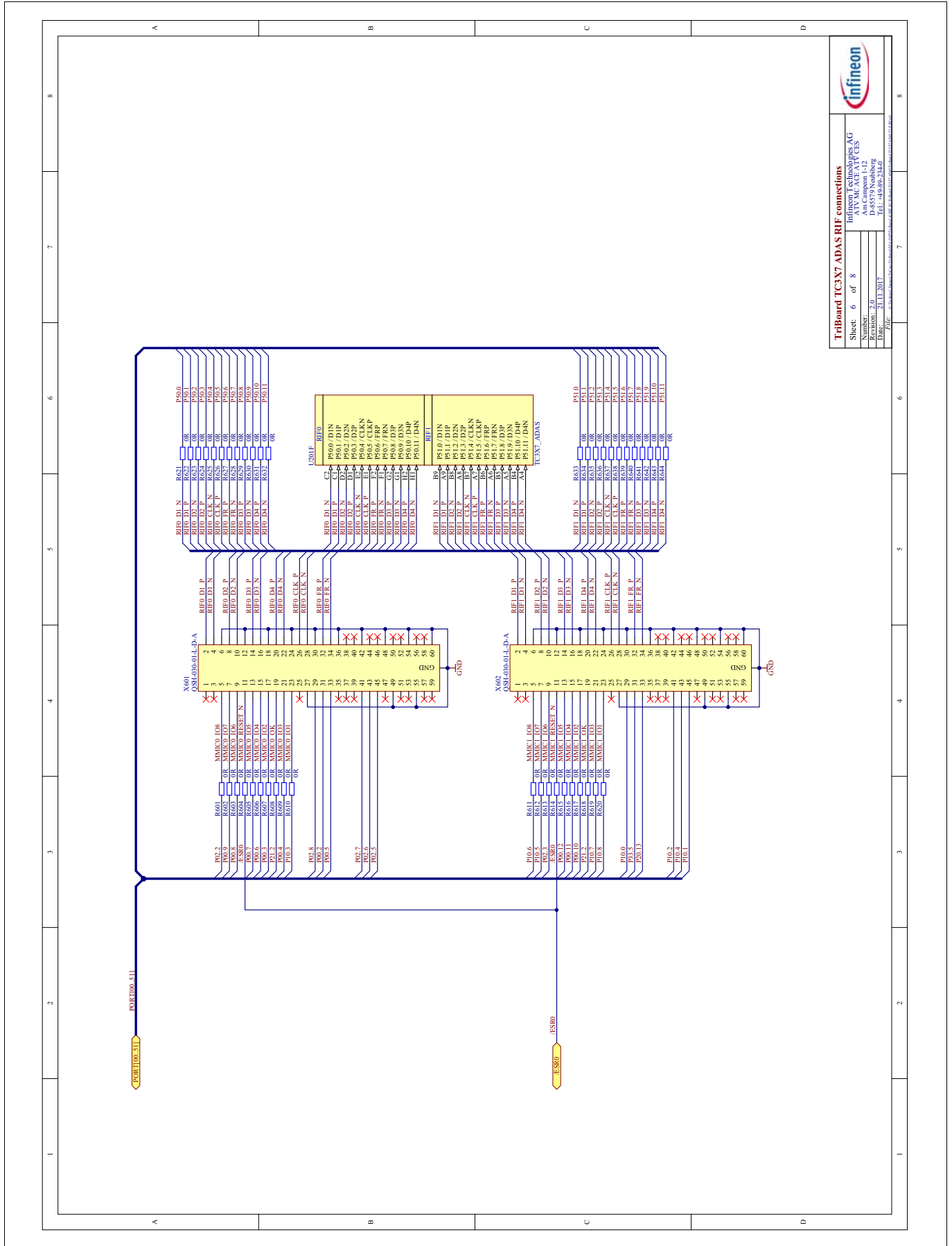

Figure 7-6 Schematic - MMIC / RIF connections

Schematic and Layout

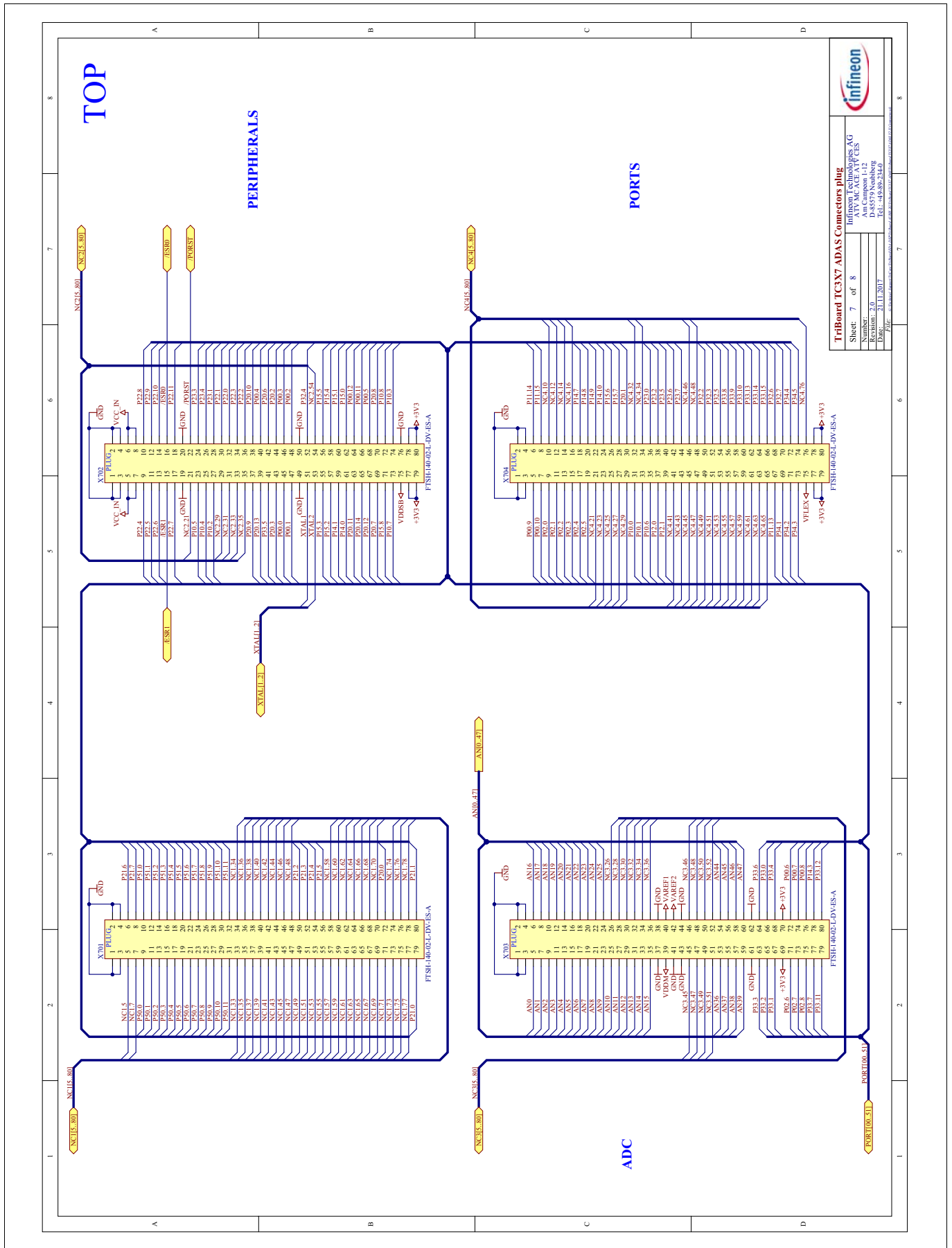

Figure 7-7 Schematic - Connectors (Plug)





Schematic and Layout

7.3 Layout

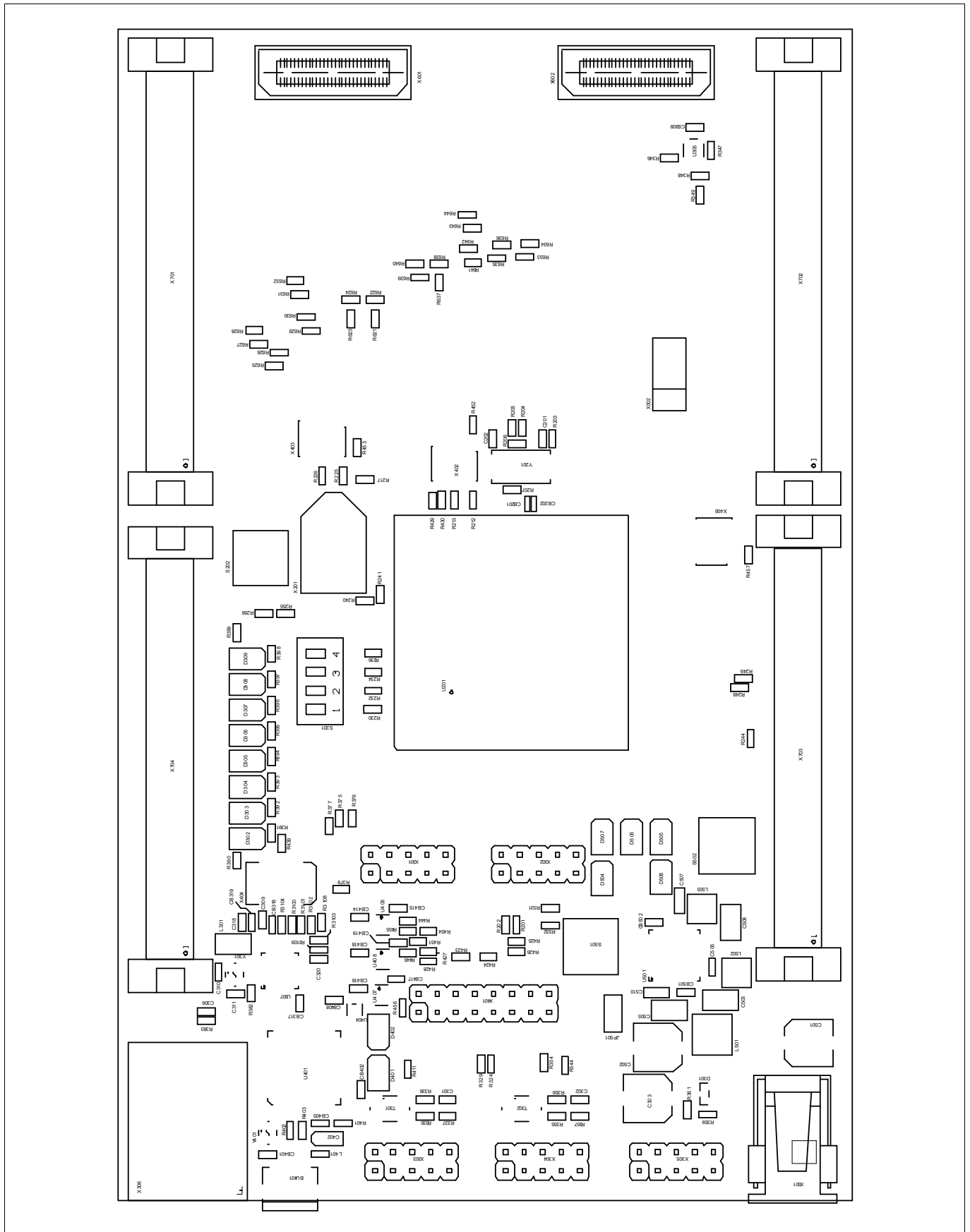
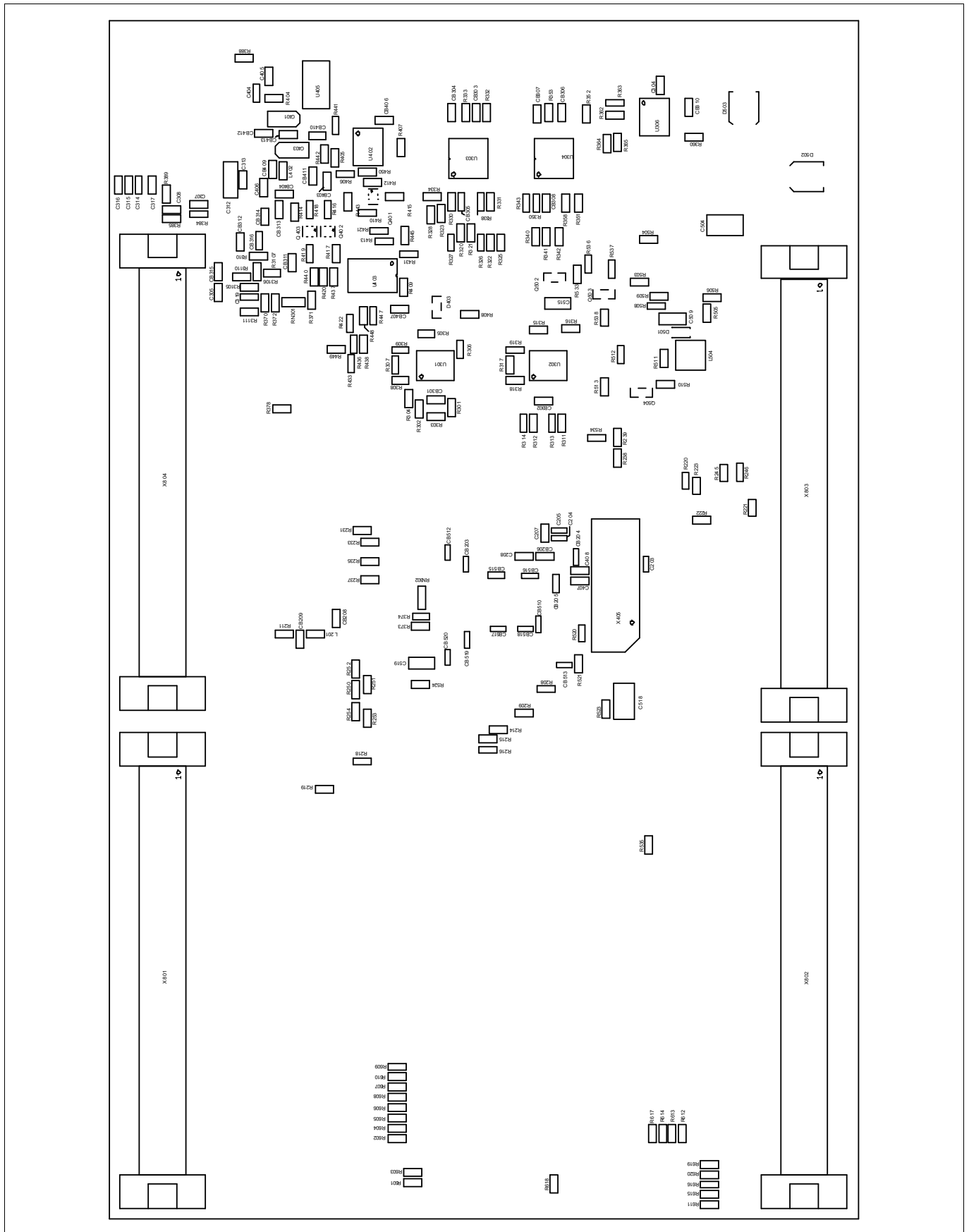

Figure 7-9 Component Plot Top Layer

**Schematic and Layout**



**Figure 7-10 Component Plot Bottom Layer**

Schematic and Layout

7.4 Layout with Dimensioning

The following dimensions should be used for development of extension boards.

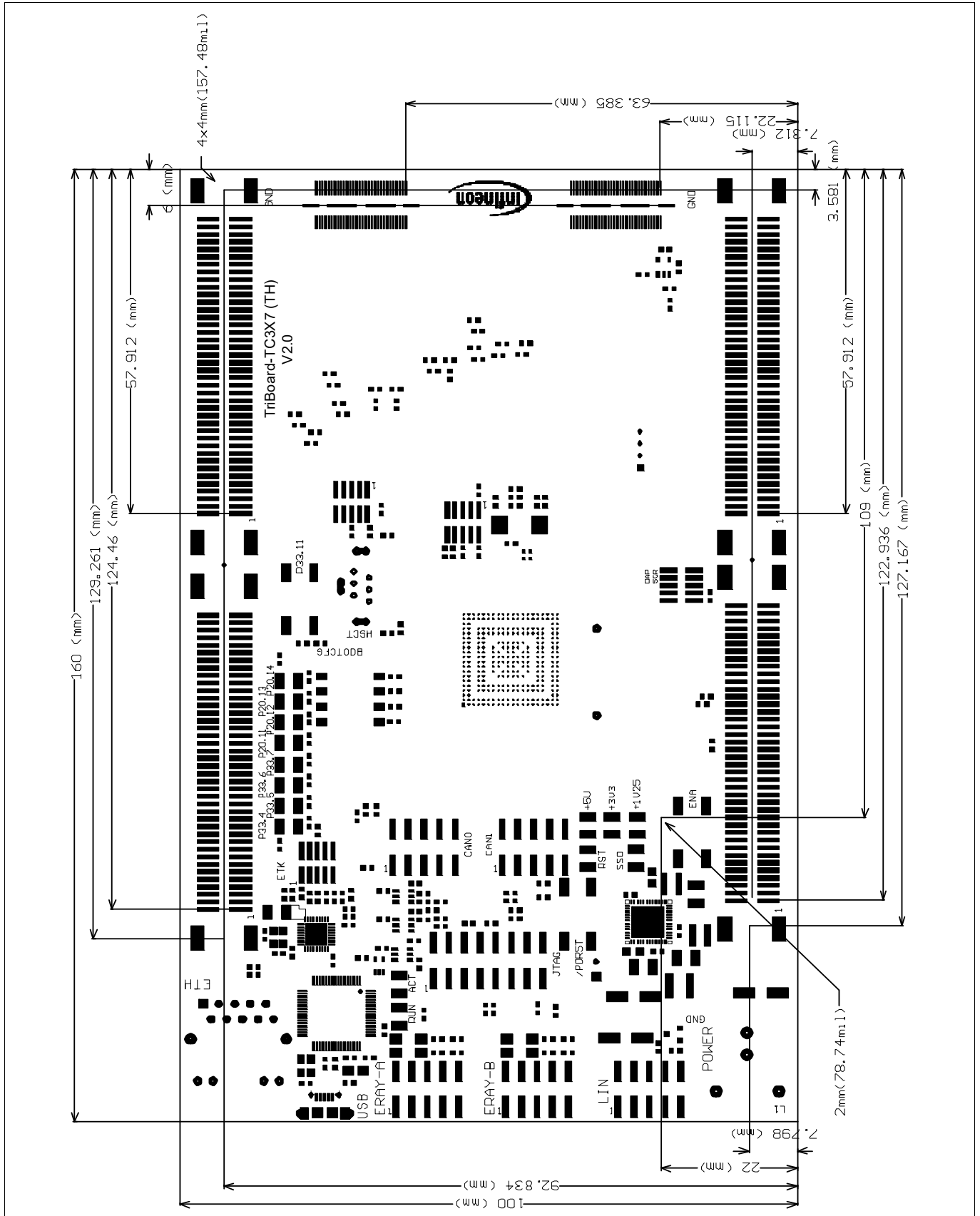

Figure 7-11 Dimensioning (mm)

Schematic and Layout

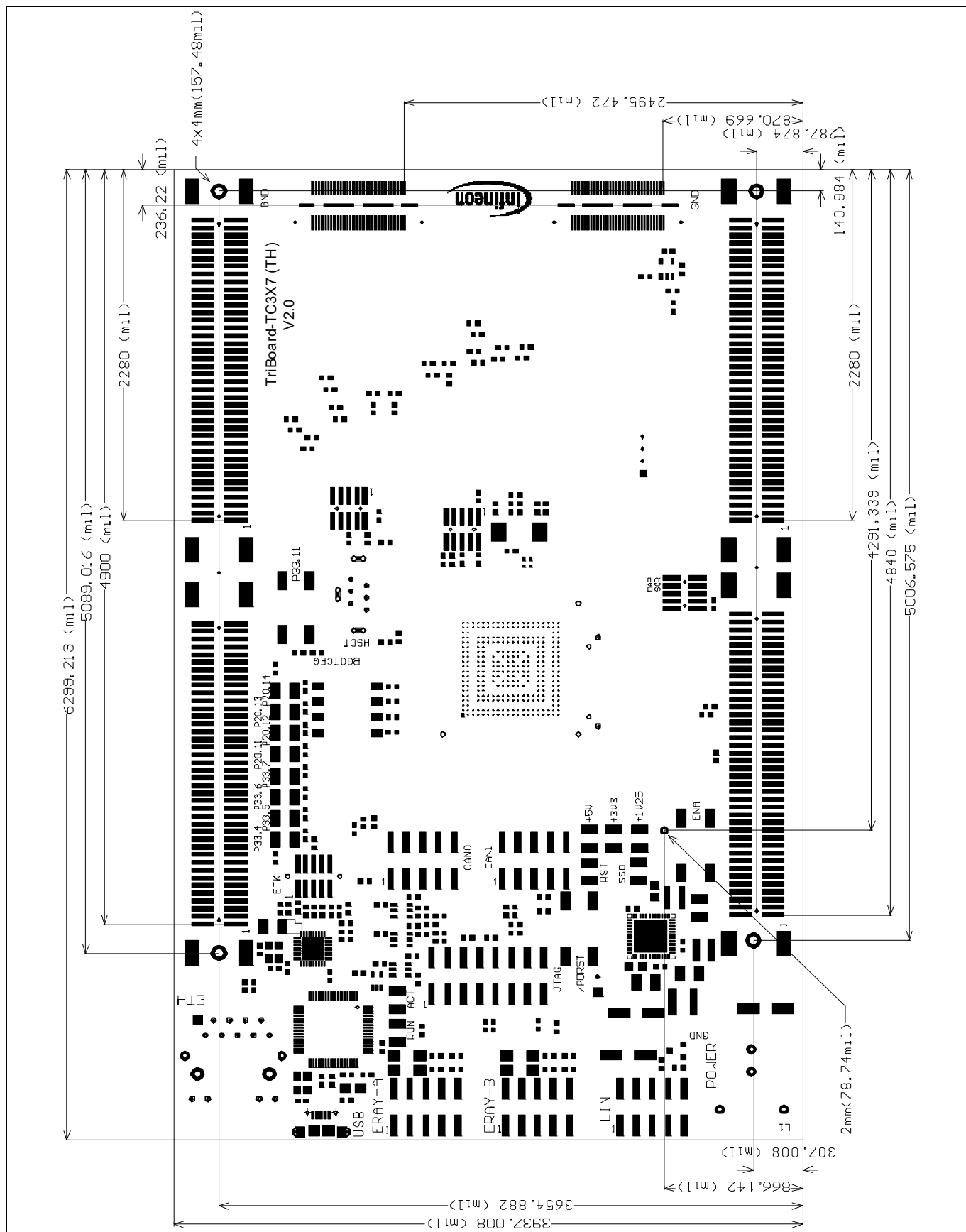

Figure 7-12 Dimensioning (mil)

The dimensioning is valid for all TriBoards.

**Revision History**

<b>Page or Item</b>	<b>Subjects (major changes since previous revision)</b>
<b>V2.4, 2020-02</b>	
all	Name of supply IC from TLF3068X to TLF30682 changed and unavailable device (684) removed
chapter 2.1	Unusable safe state LED removed
chapter 2.2	Figure 2-1 corrected (WAKEUP from CPU to power supply removed)
chapter 3.3.1	Error pin monitoring removed (not available on TLF30682QVS01)
chapter 3.3.1 and 3.17	Name of S502 corrected from WAKE to ENA
chapter 3.4	Description for SSO changed
chapter 5.6	Connection description for P33.8 and P33.9 updated
chapter 6.1	Description of P14.4 corrected
chapter 7.2	Hint about power supply device added
<b>V2.3, 2019-08</b>	
chapter 3.2.1	hint (planned, not yet tested) removed for TC337
chapter 3.9	add hint that CAN1 is not usable with TC337 and TC3A7
chapter 3.9	add hint for eeprom access with TC337 (no I2C module)
chapter 3.11	add description for LIN master and slave changes
Figure 2-1	add hint ERAY and CAN1 not with TC337 and TC3A7
Revision History	add complete history of all previous versions
all	add TC3A7 as usable (planned) device and adapt description for this devices.
<b>V2.2, 2019-06</b>	
all	add TC337 as usable (planned) device and adapt description for this devices. Add some notes for peripheral availability on different devices
chapter 6	add separat connector layout for TC337
chapter 3	add detailed description of usable devices/restricted devices
<b>V2.1, 2018-09</b>	
all	add TC357 as usable device and adapt description for TC357
<b>V2.0, 2017-11</b>	
all	adapt to new board hardware V2.0 from V1.0

#### Trademarks of Infineon Technologies AG

$\mu$ HVIC™,  $\mu$ IPM™,  $\mu$ PFC™, AU-ConvertIR™, AURIX™, C166™, CanPAK™, CIPOS™, CIPURSE™, CoolDP™, CoolGaN™, COOLiR™, CoolMOS™, CoolSET™, CoolSiC™, DAVE™, DI-POL™, DirectFET™, DrBlade™, EasyPIM™, EconoBRIDGE™, EconoDUAL™, EconoPACK™, EconoPIM™, EiceDRIVER™, eupec™, FCOS™, GaNpowIR™, HEXFET™, HITFET™, HybridPACK™, iMOTION™, IRAM™, ISOFACE™, IsoPACK™, LEDriviR™, LITIX™, MIPAQ™, ModSTACK™, my-d™, NovalithIC™, OPTIGA™, OptiMOS™, ORIGA™, PowIRaudio™, PowIRstage™, PrimePACK™, PrimeSTACK™, PROFET™, PRO-SIL™, RASIC™, REAL3™, SmartLEWIS™, SOLID FLASH™, SPOC™, StrongIRFET™, SupIRBuck™, TEMPFET™, TRENCHSTOP™, TriCore™, UHVIC™, XHP™, XMC™.

Trademarks updated November 2015

#### Other Trademarks

All referenced product or service names and trademarks are the property of their respective owners.

**Edition 2020-02**

**Published by**

**Infineon Technologies AG**

**81726 Munich, Germany**

**© 2020 Infineon Technologies AG.**

**All Rights Reserved.**

**Do you have a question about any aspect of this document?**

**Email: [erratum@infineon.com](mailto:erratum@infineon.com)**

**Document reference**

**Doc\_Number**

#### IMPORTANT NOTICE

The information given in this document shall in no event be regarded as a guarantee of conditions or characteristics ("Beschaffheitsgarantie").

With respect to any examples, hints or any typical values stated herein and/or any information regarding the application of the product, Infineon Technologies hereby disclaims any and all warranties and liabilities of any kind, including without limitation warranties of non-infringement of intellectual property rights of any third party.

In addition, any information given in this document is subject to customer's compliance with its obligations stated in this document and any applicable legal requirements, norms and standards concerning customer's products and any use of the product of Infineon Technologies in customer's applications.

The data contained in this document is exclusively intended for technically trained staff. It is the responsibility of customer's technical departments to evaluate the suitability of the product for the intended application and the completeness of the product information given in this document with respect to such application.

For further information on technology, delivery terms and conditions and prices, please contact the nearest Infineon Technologies Office ([www.infineon.com](http://www.infineon.com)).

#### WARNINGS

Due to technical requirements products may contain dangerous substances. For information on the types in question please contact your nearest Infineon Technologies office.

Except as otherwise explicitly approved by Infineon Technologies in a written document signed by authorized representatives of Infineon Technologies, Infineon Technologies' products may not be used in any applications where a failure of the product or any consequences of the use thereof can reasonably be expected to result in personal injury.