

CMX/CCP V6.0 (Solaris)

WAN Communication

Comments... Suggestions... Corrections...

The User Documentation Department would like to know your opinion of this manual. Your feedback helps us optimize our documentation to suit your individual needs.

Fax forms for sending us your comments are included in the back of the manual.

There you will also find the addresses of the relevant User Documentation Department.

Certified documentation according DIN EN ISO 9001:2000

To ensure a consistently high quality standard and user-friendliness, this documentation was created to meet the regulations of a quality management system which complies with the requirements of the standard DIN EN ISO 9001:2000.

cognitas. Gesellschaft für Technik-Dokumentation mbH
www.cognitas.de

Copyright and Trademarks

Copyright © 2003 Fujitsu Siemens Computers GmbH.

All rights reserved.

Delivery subject to availability; right of technical modifications reserved.

All hardware and software names used are trademarks of their respective manufacturers.

This manual is printed on
paper treated with
chlorine-free bleach.

Preface

Functionality and scope of CCP-WAN

Operating CCP-WAN

The WAN-NEA profile

The WAN-NX25 profile

The WAN-CONS profile

The WAN-X25 profile

The WAN-SDLC profile

The WAN-FR profile

Two-step dialing to and from an X.25 network via a phone network to X.32

Continued ►

Configuration with KOGS macros

FSS configuration

Administration and diagnostics

Administration and diagnostic commands for the Transport Service Providers (TSPs)

Diagnostics and Fault-finding

Indexes

Contents

1	Preface	1
1.1	Brief description of the CCP-WAN products	1
1.2	Target group	2
1.3	Summary of contents	2
1.4	Notational conventions	3
1.5	README files and man files	6
2	Functionality and scope of CCP-WAN	7
2.1	Hardware requirements	7
2.2	Software requirements	8
2.3	WAN types	10
2.3.1	Dedicated lines	10
2.3.2	Circuit switching networks	10
2.3.3	Packet switching networks	11
2.3.4	Frame relay networks	18
2.4	User facilities of a dedicated line interface	23
2.5	User facilities of a switched line	24
2.6	User facilities of the X.25 interface	24
2.6.1	Packet switching protocols	24
2.6.2	X.25 concepts	27
2.6.3	Functions at the packet level	30
2.6.4	Optional user facilities in X.25 networks	32
2.7	Features of the frame relay interface	36
2.7.1	Protocols for frame relay	36
2.7.2	Frame relay concepts	37
2.7.3	Functions at the link layer	39
2.8	Point-to-point protocol for TCP/IP routing	43
2.9	Selecting an alternative network connection	44
2.10	Two-step dialing to and from X.25 networks via telephone networks	47
2.10.1	How X.32 dialing works	48
2.10.2	Special operational aspects	49
2.11	Access control	51
2.11.1	Examples of access control configuration	53
2.11.1.1	Subnet ID-specific block for all incoming calls	53
2.11.1.2	Subnet ID-specific block for unknown callers	53
2.12	Architecture of CCP-WAN	56
3	Operating CCP-WAN	59
3.1	Installation	60
3.2	Setting up the local subnet connection	62

Contents

3.3	Creating a configuration	63
3.4	Editing configuration files with the menu system	64
3.4.1	Access to the menu system via the CMXCUI command	64
3.5	Editing a configuration file in expert mode	65
3.6	Compiling a KOGS source file	65
3.7	Assigning and loading the configuration file	66
3.7.1	Assigning network access software and configuration file to a CC	66
3.7.2	Loading the WAN network access software and configuration file	68
3.8	Configuring partner systems	69
3.8.1	Defining routes to remote subnetwork interfaces via the menu system	70
3.8.2	Entering partner systems via the menu system	71
3.8.3	Entering transport system applications via the menu system	72
3.8.4	Entering access coe menu system	73
3.8.5	Setting X.32 two-step dialing via the menu system	74
3.9	Deinstallation	75
4	The WAN-NEA profile	77
4.1	Profile description	77
4.2	Bundled lines (Multilink)	79
4.3	Configuring a default route	80
4.4	KOGS, FSS and TNS parameters	82
4.4.1	KOGS parameters	82
4.4.2	FSS parameters	84
4.4.3	TNS parameters	88
4.5	Configuration using the menu system	89
4.5.1	Configuring the local subnetwork interface	89
4.5.2	Defining your own network address	90
4.5.3	Defining routes	90
4.5.4	Entering partner systems	91
4.5.5	Entering transport system applications	92
4.6	Examples	93
4.6.1	WAN-NEA: dedicated lines, balanced	93
4.6.2	WAN-NEA: dial-up line, remote dialing	95
4.6.3	WAN-NEA: dedicated line, unbalanced, point-to-point	98
4.6.4	WAN-NEA: multipoint secondary (for SK12)	99
5	The WAN-NX25 profile	101
5.1	Profile description	101
5.2	Configuring a default route	102
5.3	NEA routing	104

5.4	KOGS, FSS and TNS parameters	105
5.4.1	KOGS parameters	105
5.4.2	FSS parameters	107
5.4.3	TNS parameters	112
5.5	Configuration using the menu system	113
5.5.1	Configuring the local subnetwork interface	113
5.5.2	Defining your own network address	114
5.5.3	Defining routes	114
5.5.4	Entering partner systems	115
5.5.5	Entering transport system applications	116
5.6	Examples	117
5.6.1	WAN-NX25 SVC with facilities	117
5.6.2	WAN-NX25 PVC without facilities	118
5.6.3	Selecting an alternative network port	119
6	The WAN-CONS profile	121
6.1	Profile description	121
6.2	Special operational aspects of WAN-CONS with the T.70 protocol	123
6.3	KOGS, FSS and TNS parameters	124
6.3.1	KOGS parameters	124
6.3.2	FSS parameters	127
6.3.3	TNS parameters	132
6.4	Configuration using the menu system	134
6.4.1	Configuring the local subnetwork interface	134
6.4.2	Defining routes	135
6.4.3	Entering partner systems	136
6.4.4	Entering transport system applications	136
6.5	Examples	137
6.5.1	WAN-CONS SVC without facilities	137
6.5.2	WAN-CONS SVC with facilities	138
6.5.3	WAN-CONS via a dedicated line (T.70)	139
6.5.4	WAN-CONS via a dial-up line (T.70)	140
6.5.5	Selecting an alternative network port	141
7	The WAN-X25 profile	143
7.1	Profile description	143
7.2	KOGS, FSS and TNS parameters	145
7.2.1	KOGS parameters	145
7.2.2	FSS parameters for X.25 applications and SNA applications via X.25	147
7.2.3	FSS parameters for TCP/IP via X.25	151
7.2.4	TNS parameters	155

Contents

7.3	Configuration using the menu system	157
7.3.1	Configuring the local subnetwork interface	157
7.3.2	Defining routes	158
7.3.3	Entering partner systems	160
7.3.4	Entering transport system applications	161
7.4	Assignment of Connect Indications to Applications	162
7.5	Examples	167
7.5.1	X.25 applications and SNA applications via an X.25 SVC	167
7.5.2	TCP/IP via an X.25 SVC	168
7.5.3	X.25 partner facilities in the FSS	169
7.5.3.1	Special case: Fast Select	169
7.5.3.2	Special case: Reversed Charging	170
7.5.4	Selecting an alternative network port	171
8	The WAN-SDLC profile	173
8.1	Profile description	173
8.2	KOGS, FSS and TNS parameters	176
8.2.1	KOGS parameters	176
8.2.2	FSS parameters	178
8.2.3	TNS parameters	178
8.3	Configuration using the menu system	179
8.3.1	Configuring the local subnetwork interface	179
8.3.2	Entering transport system applications	180
8.4	Examples	181
8.4.1	WAN-SDLC primary dedicated line	181
8.4.2	WAN-SDLC primary dial-up line	182
8.4.3	Direct link	183
9	The WAN-FR profile	185
9.1	Profile description	185
9.2	KOGS, FSS and TNS parameters	189
9.2.1	KOGS parameters	189
9.2.2	FSS parameters	190
9.2.3	TNS parameters	194
9.3	Configuration using the menu system	195
9.3.1	Configuring the local subnetwork interface	195
9.3.2	Defining routes	196
9.3.3	Entering partner systems	196
9.4	Examples	197
9.4.1	TCP/IP via frame relay	197

10	Two-step dialing to and from an X.25 network via a phone network to X.32	199
10.1	Profile description	199
10.2	KOGS, FSS and TNS parameters	201
10.2.1	KOGS parameters	201
10.2.2	FSS parameters	205
10.2.3	TNS parameters	210
10.3	Configuration using the menu system	213
10.3.1	Configuring the local subnetwork interface	213
10.3.2	Defining routes	215
10.3.3	Entering partner systems	217
10.3.4	Entering transport system applications	218
10.4	Examples	219
10.4.1	X.32 dialing with the WAN-NX25 profile	219
11	Configuration with KOGS macros	223
11.1	Creating a configuration file	224
11.1.1	Syntax rules for KOGS source files	225
11.1.2	Call sequence for KOGS macros	228
11.2	Overview of KOGS macros	229
11.3	KOGS macros	237
11.3.1	XEND - end of a KOGS source	237
11.3.2	XFACI - define facilities	237
11.3.3	XLTNG - define line operands	243
11.3.4	XPRO - define link addresses and XID exchange	259
11.3.5	XSNID - define subnet ID	261
11.3.6	XSYSP - start KOGS	262
11.3.7	XZSTW - define X.25 access with X.32 dialing	263
12	FSS configuration	269
12.1	FACIL object class	273
12.2	GNSAP object class	279
12.3	LOCNSAP object class	280
12.4	NSAP object class	281
12.5	SNPAROUTES object class	283
12.6	SUBNET object class	287
13	Administration and diagnostics	289
13.1	Administration commands	293
13.1.1	ach - Activate line	293
13.1.2	assign - Assign network access software to a CC	294
13.1.3	compile - Compile configuration source file	295
13.1.4	cronstart - Activate "automatic reload"	295
13.1.5	cronstop - Deactivate "automatic reload"	295

Contents

13.1.6	dah - Deactivate line	296
13.1.7	exchange - Exchange configuration file	297
13.1.8	info - Query CC status information	298
13.1.9	linkstat - Display status of the CC connections	299
13.1.10	load - Load network access software	301
13.1.11	list - List configuration files	301
13.1.12	stop - Deactivate network access software	302
13.2	Diagnostics commands	303
13.2.1	dump - Dump CC memory	303
13.2.2	format - Edit trace lists and dumps	303
13.2.3	sof - Switch off trace list	306
13.2.4	son - Switch on trace list	308
13.2.5	tof - Switch off trace list transfer	310
13.2.6	ton - Switch on trace list transfer	311
13.3	Help functions	313
13.3.1	cmdfile - Execute command file	313
13.3.2	: Change administered CC	313
13.3.3	? List diagnostic commands	314
13.3.4	! Execute shell command	314
13.3.5	# Enter comment in the command file	315
14	Administration and diagnostic commands for the Transport Service Providers (TSPs)	317
14.1	Operational readiness of the Transport Service Providers	317
14.2	TSP statistics	319
14.3	Switching NEA routing on and off	320
15	Diagnostics and Fault-finding	321
15.1	Diagnostic files	322
15.2	Traces and statistics	323
15.3	ccptron, ccptroff – Switching traces on and off	325
15.4	x25snoop – Carrying out line-specific X.25 protocol tracing	326
15.5	x25chk, x25conf – X.25 connection test	333
15.5.1	x25chk	333
15.5.2	x25conf	337
Glossary	341
Abbreviations	351
Related publications	357
Index	361

1 Preface

1.1 Brief description of the CCP-WAN products

CMX/CCP V5.1 for Solaris provides you with a versatile communications package that allows you to connect UNIX systems to other UNIX systems, BS2000 systems, or non-SNI systems via public and private wide area networks.

The following diagram shows the product structure of the various communication options for UNIX computers with WAN connections:

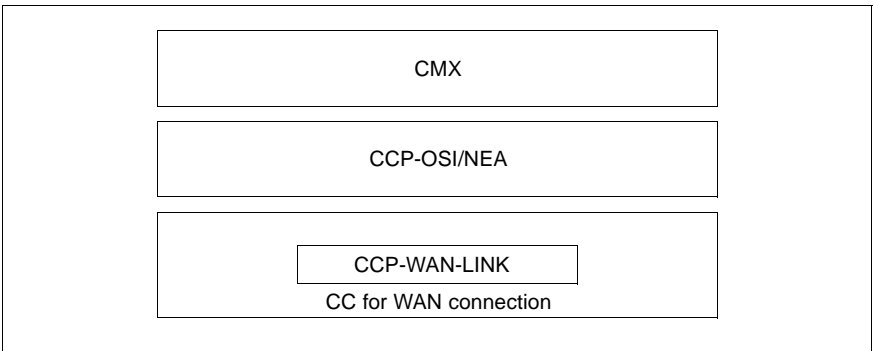

Figure 1: Product structure for CCP-WAN

CCP-WAN-LINK	for operating Communications Controllers for WAN connections (V.24, X.21, X.25, Frame Relay)
CCP-OSI/NEA	for networking computers with NEA and OSI protocols
CMX	Base product required for operating WAN/ISDN controllers; programming interface for CMX applications; for networking computers with TCP/IP protocols via WAN (SW router) and LAN (RFC1006)

In this manual, the term “CCP-WAN products” or the abbreviation “CCP-WAN” (Communication Control Program for Wide Area Networks) is used to refer to the products mentioned above.

CCP-WAN can be used, in combination with other add-on products if required, to establish connections to dedicated lines as well as circuit switching, telephone, packet switching, and frame relay networks. A suitable Communications Controller (CC) is required to run CCP-WAN. The functions of CCP-WAN are made available via the Communication Manager UNIX (CMX).

A scalable access control system in CCP-WAN protects your systems from unauthorized access.

CCP-WAN allows you to use different protocol profiles at the same time via the same Communications Controller.

CMX has a character-oriented user interface (CMXCUI) for configuring operating parameters and for supporting maintenance and diagnostics.

The description of CCP-WAN provided in this manual is for Solaris systems. Information on running CCP-WAN on a particular UNIX system can be obtained from the relevant Release Notice.

ICMX and XTI are available as program interfaces.

1.2 Target group

This manual is intended for network administrators and system administrators.

In order to use it effectively, you will need a basic knowledge of the operating system and should also be familiar with the fundamental principles of data communication and the functionality of CMX.

1.3 Summary of contents

The following section summarizes the contents of the individual chapters in this CCP-WAN User Guide.

Chapter 2 describes the functionality and scope of CCP-WAN.

Chapter 3 contains instructions on starting and stopping CCP-WAN and explains how configuring the system via the menu system and in expert mode is inter-related.

Chapters 4 to 9 describe how the individual CCP profiles are configured. Each chapter ends with examples to illustrate the respective configurations.

Chapter 10 describes the configuration of two-step dialing to and from X.25 networks via the phone network (X.32 dialing).

Chapter 11 describes how configuration files can be created with the help of KOGS macros. It also includes detailed descriptions of all KOGS macros with their possible operands.

Chapter 12 contains the FSS parameters that are relevant for CCP profiles.

Chapter 13 contains the administration commands for CCP-WAN.

At the back of the manual, you will find a list of abbreviations, a glossary, references, and an index.

1.4 Notational conventions

As far as possible, all command descriptions adhere to a fixed structure:

- description of the command
- syntax
- syntax definitions
- exit status
- error messages
- files
- example
- see also

These components of the command description are explained below.

Brief description of the command

In each command description, this section contains the following information:

- how the command works
- the different tasks of the various command formats, if several formats are used
- the context in which the command is to be used (e.g. entries in files, access rights), background information

Syntax

cmd[**_a**][**_b**][**_c**][**_d** *arg1*][**_f** *arg2*]**_file**...

This example indicates that you must enter *cmd* and specify one or more files for *file*, where each file name is separated by a blank space. You can also specify the following:

- one or more options *-a*, *-b*, *-c*, either individually (**-a****_b****_c**) or together (**-abc**)
- option *-d*, where *arg1* must be replaced by an argument
- option *-f*, where *arg2* must be replaced by an argument

The following metasyntax is used:

Bold text

Constants. Bold characters must be entered exactly as shown.

Normal characters

Variables. These represent other characters which you must select and enter.

[] Options. Arguments in square brackets are optional. The brackets must not be entered, unless specified otherwise.

_ Mandatory blank.

... The previous expression may be repeated. If each repeated expression is to be preceded by a blank, a _ appears before the ellipsis (...).

| Selection options. You must select one of the expressions that are separated by a vertical line.

underscoring

Default value.

Syntax definitions

This section describes the various options and arguments (input files, parameters, variables, etc.) that you can enter when invoking a command. No distinction is made between constants and variables in the body text; however, all syntax elements, file names, path names, and commands are printed in *italics*.

Exit status

The exit status is a value that is returned by a command to its invoking process following execution. This value indicates whether or not the command was executed successfully. It is a numeric value and is stored in the `?` variables. You can query the exit status by using the `echo $?` command.

The exit status is only described if it differs from the following default values:

- 0 if the command was successful
- ≠0 if an error occurred

Errors

This section contains the main error messages, as well as information on how to avoid and recover from errors.

Error messages are generally output to standard error output (*stderr*), which is normally the screen.

Files

This section specifies the files accessed or created by the command.

Example

Examples are used to explain the main function of the command, the use of essential options, and practical combinations of options and arguments. In sample applications, inputs to the system are indicated by **bold typewriter** text. Since all of these input lines are terminated with ENTER, this key is not explicitly specified at the end of each line.

Outputs from the system are indicated by normal *typewriter text*, except when they appear in the body text, in which case they are written in *italics*.

See also

This section provides references to other commands which are similar in functionality or which interact with the command described. It may also refer to other publications relevant for that command.

Notes and warnings



This symbol indicates particularly important information that should be noted.

**Caution!**

This symbol indicates a risk of data loss or damage to a device.

1.5 README files and man files

Information on any functional changes and additions to the current product version can be found in product-specific Release Notices. You will find these notices in the readme package which is supplied with the relevant product.

There are also online manual pages for the CMX/CCP products which can be accessed once the product has been installed.

2 Functionality and scope of CCP-WAN

This chapter provides you with an overview of the functionality of CCP-WAN and the various ways in which it can be used.

CCP-WAN-LINK enables a UNIX system to access a WAN. This means that your UNIX system can communicate via a WAN with other UNIX systems and with TRANSDATA NEA, OSI or SNA systems if used with the appropriate add-on products (see table “Overview of CCP profiles, subnet interfaces and interface types” on page 57). You can also communicate with PCs and with other non-SNA systems, provided these systems support the ISO transport protocols or TCP/IP. In addition, CCP-WAN also supports connections to frame relay networks.

A scalable access control system in CCP-WAN protects your systems from unauthorized access.

You can define which communication protocols are to be used for each connection that is set up.

2.1 Hardware requirements

The main hardware required by a UNIX system for WAN communications is a set of suitable component groups, which comprise the so-called **Communications Controller** (CC). Depending on the type of CC, up to four connectors may be present on the CC for X.21 and/or V.24 ports.

The WAN-CCs are loadable CCs, which means that they must be operated with the associated Communication Control Program (CCP-WAN) in order to set up a *logical* connection to the WAN. If multiple ports are used, each port can be configured independently of the others. It is only after loading a configuration file that a connection can be set up via a CC.

The type and the device status of CCs and other version-specific hardware and software dependencies are described in the Release Notice for CCP-WAN-LINK.

2.2 Software requirements

The main software requirement for the use of CCP-WAN is the base product of CMX (Communication Manager UNIX) and CCP-WAN-LINK, which must be installed. Depending on the individual situation, other software products may be required.

Version-specific dependencies for hardware and software can be found in the Release Notice.

Communications Manager UNIX (CMX)

CMX arbitrates between the current network and applications and provides the network administrator with unified functions for OA&M (operation, administration and maintenance) of CCP and CC.

CMX unifies the services of different networks and thereby allows the same application to be used independent of the underlying network.

Both CMX and CCP-WAN have a character-oriented user interface CMXCUI (CUI=Character User Interface). You can configure and operate CCP-WAN via menus using CMXCUI.

You do not require any additional products for TCP/IP communication via WAN. Among other things, CMX allows you to transfer the TCP/IP packets using the point-to-point-protocol (PPP).

CCP-WAN-LINK

Special software is required to load and operate a Communications Controller. This software is included in the installation unit CCP-WAN-LINK.

NEA protocol (NEA)

In order to communicate with a partner by means of the NEA transport protocol, you will need the software product CCP-OSI/NEA. This will enable you to set up WAN links via circuit switching networks (WAN-NEA profile) as well as packet switching networks (WAN-NX25 profile).

OSI protocol (ISO)

In order to communicate with a partner using the OSI transport protocol, you will need the software product CCP-OSI/NEA. This will allow you to use the OSI protocols both via X.25 (packet switching network) as well as T70-3 (circuit switching network).

TRANSIT software (TRANSIT-SERVER)

The product TRANSIT-SERVER is required for SNA communications via a WAN. You will find a description of how to configure your UNIX system for SNA communications in the manual "Interfacing to SNA Networks" [5].

2.3 WAN types

This section describes four types of WAN (wide area networks):

- Networks which consist of dedicated lines.
- Circuit Switched Data Networks (CSDN), e.g. the telephone network.
- Packet Switched Data Networks (PSDN) based on X.25, e.g. the Datex-P network of Deutsche Telekom.
- Frame relay networks, which are similar to packet switching networks but have a much higher transmission rate.

If a user wishes to connect two or more computers to form a network, it is quite possible that the resultant network will not be homogeneous. For example, some connections may have been implemented using dedicated lines, while others use the public telephone network and others again use the ISDN network. Which type of network is used in a particular case depends on the local connections, the distance involved, the data throughput rate, the requirements with regards to availability and security, and the costs. It is also possible to set up several alternative connections or bundles.

2.3.1 Dedicated lines

Dedicated lines enable duplex data communication between the two end points of the line. In the private or company sector they often offer a simple and cost-effective means of establishing a connection between two devices. For remote connections, dedicated lines can be leased from network providers.

2.3.2 Circuit switching networks

Circuit switching is a process by which a direct transmission path for the exchange of information is made available to the partner entities for the duration of the connection, regardless of whether or not information is being transferred.

Circuit-switched data networks (CSDN)

Circuit switching networks include public or private circuit switching networks that support the standard protocols of CCITT and ISO.

Switched telephone networks (public telephone, PT)

Switched telephone networks include the public telephone networks of the national PTT administrations (such as Deutsche Telekom AG) and of other providers.

2.3.3 Packet switching networks

Packet switching is usually executed via a packet switched data network (PSDN). The Datex-P network of the Deutsche Telekom (German PTT) is an example of a PSDN. A detailed description of the Datex-P network can be found in the "DATEX-P manual" [6].

This description also applies to all X.25 offers of the other network providers.

Characteristics of packet switching

The basic characteristics of packet switching are:

- splitting of the data to be transferred into packets
- data exchange via virtual connections
- implementation of virtual connection via logical channels

A brief description of these and other facilities is given below.

Communication partners

The communication partners in packet switching are generally in packet-mode data terminal equipment (DTE). Communication is possible either between application programs or between application programs and terminals. Packet-mode DTEs are either X.25 terminals or computers which support the standard protocols of packet switching.

Protocols

The packet switching protocols are standardized by recommendations of CCITT (Comité Consultatif International Télégraphique et Téléphonique) and ISO (ISO = International Organization for Standardization). The most important protocols for packet switching are CCITT Recommendation X.25 and ISO standards IS 7776 and IS 8208. Recommendation X.25 describes the access protocol to a packet switching network. It describes the lower three layers of the OSI (Open Systems Interconnection) Reference Model.

Data network

A DTE can be connected either directly (via a dedicated line) or indirectly (via a circuit switching network) to a packet switching network (PSDN), i.e. to a node of the PSDN. It is also possible to link two packet-mode DTEs via a circuit switching network.

Packets

The data to be transferred is split into packets and the packets are then transferred consecutively over the network. The packets have a fixed maximum length. They contain the data to be transferred and additional administrative information that is needed for the packet to be sent to the correct destination.

The DTE splits the data to be transferred into packets. It generates the administrative information and adds it as a prefix to the data. The DTE transfers the data packets to the data circuit-terminating equipment (DCE), which in turn transfers them to the network. The network transports the packets further to the receiving DTE.

The packets are accepted at the destination address by the appropriate DCE and forwarded to the receiving DTE. In the DTE, the administrative information is removed from the data packets and the data is recombined. The packets are presented to the receiver in the correct sequence, so that data distributed over several packets is once more in complete form.

Virtual connection

Data exchange between the sending and receiving DTEs is handled via a virtual (software-generated) connection. The distinction between a virtual connection and a physical connection is that the physical line (the connection of the DTE to the network) is **not** assigned exclusively to the virtual connection but only for the time it takes to transmit each individual packet. This means that a physical line can be used by a number of virtual connections at the same time. Several logical channels can therefore be assigned to the DTE network connection. To set up a virtual connection, you need one logical channel of the sending DTE and one logical channel of the receiving DTE. Each virtual connection thus uses one logical channel of the connection.

There are two types of virtual connections:

- Switched virtual call (SVC). This is set up and cleared down as required using special control packets. It therefore occupies a logical channel only for as long as the virtual connection exists.

- Permanent virtual circuit (PVC). Two DTEs are permanently assigned to one another. The PVC is defined in consultation with the network provider of the PSDN. It is always available and always on the same logical channel. It is therefore never set up or cleared down.

In the case of direct or indirect connection of the DTE to a PSDN, virtual connections to communication partners on a number of different remote DTEs in the PSDN can be set up.

Direct connection means that the DTE is connected via a dedicated line to a node of a PSDN.

Indirect connection means that the DTE is connected via a circuit switching network to a PSDN.

When two packet-mode DTEs are linked via a circuit switching network, only virtual connections to different communication partners on a single remote DTE can exist simultaneously via one access.

Logical channel

A logical channel is a logical connection of a DTE to the network. The logical channels implement virtual connections. Exactly one logical channel is assigned to each virtual connection. Each channel has its own number. Technically, you can assign the channel numbers 1 through 4095 for virtual connections. The channel number 0 is reserved for system messages. In the case of a connection to a PSDN, you must agree the number of channels with the network provider. With German network providers, you can assign up to 255 logical channels to one main line. Outside Germany, channel numbers greater than 255 are also used.

You can divide the available logical channels into one domain for PVCs and one domain for SVCs. The domain for the SVC can be subdivided into domains of logical channels which permit

- incoming connections only,
- incoming and outgoing connections,
- outgoing connections only.

Criteria for connection to a packet switching network

Users may wish to connect to a PSDN for a variety of reasons:

- Accessibility
 - PSDNs currently provide national coverage in many countries.
 - The standardization of interfaces to the PSDN allows DTEs made by different manufacturers to be connected.
 - The interconnection of PSDNs both nationally and internationally allows greater freedom for data communications.
 - Access to public or semi-public databases (scientific, commercial, banking, administration) is generally possible via PSDNs.
- Cost
 - In public packet switching services, the tariff structure is not usually based on distance.
 - Since a main line can be used for a large number of virtual connections at the same time, the costs of maintaining a number of lines can be saved.
 - All users share the resources of a PSDN, which means that they are highly cost-effective.
- Availability
 - Assuming a high density of interconnections between the packet switching centers in a PSDN, there is a high probability that a particular connection will be available.
 - By implementing appropriate measures within the PSDN, faults and failures can be counteracted by alternate routes, giving the system a very high level of operational reliability.

Structure of a packet switching network

A PSDN consists of:

- packet switching centers (PSCs)
- main lines with logical channels
- data circuit-terminating equipment (DCEs)
- packet assembly/disassembly facilities (PADs) for connecting character-oriented, asynchronous DTEs to a PSDN

Figure 2 shows the general structure of a PSDN:

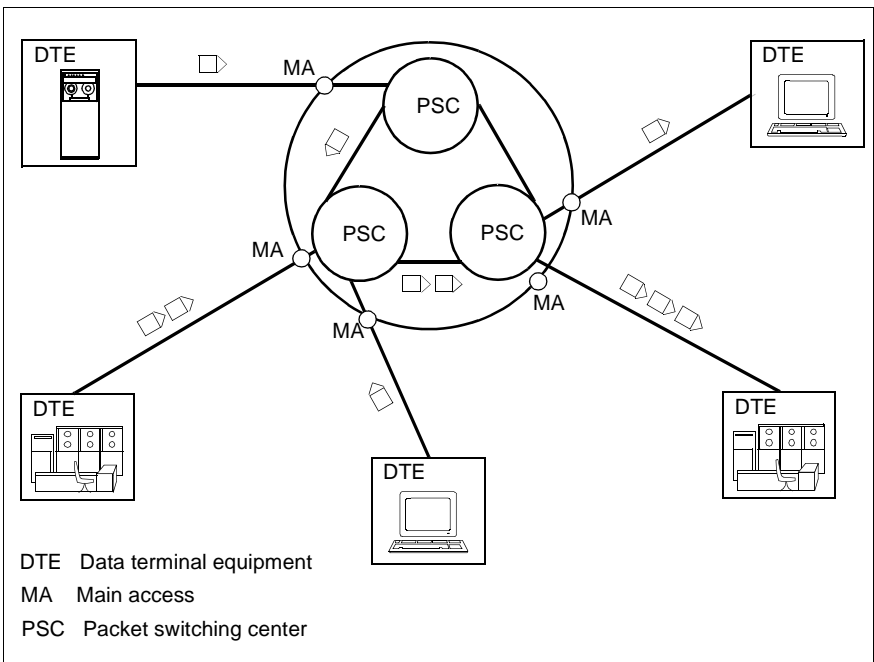

Figure 2: OSI Reference Model and CCITT Recommendation X.25

- Packet switching centers (PSCs)

The PSCs are the nodes of the PSDN. They control the transfer of data within the network. The PSCs are generally linked to one another by high-speed digital lines.

In the PSDN, the PSCs lie between the sending and receiving DTEs. They temporarily buffer the packets which the DTEs are exchanging and then forward them to the destination address.

- Main line

The main line is the physical connection of a DTE to the PSDN. It is identified by the network address.

The main line is implemented by an access line (dedicated line) and a modem. The DTE is linked via the modem to the access line.

The main line provides a fixed link, i.e. via a dedicated line, between the DTE and a PSC of the PSDN. This PSC is the *local* PSC for the DTE.

A main line can simultaneously implement several virtual connections to different DTEs. In this case, the main line requires the appropriate number of logical channels.

When a main line is configured, the following are defined:

- network address under which the main line can be reached in the PSDN
- number of logical channels assigned to the main line
- division of logical channels into SVC and PVC domains
- assignment of channel numbers to the domains
- optional X.25 user facilities to be defined with the network provider, for example output values for the data flow control and data throughput; your selection of X.25 user facilities depends on the services offered by the network provider

- Data circuit-terminating equipment (DCE)

The data circuit-terminating equipment (DCE) is the link from the PSDN to the DTE. From the DTE's viewpoint, the DCE comprises the main line of the DTE (modem and access line between DTE and local PSC) and the local PSC.

The DCE is the X.25 protocol partner of the DTE. This means that the X.25 protocol controls the data transfer between DTE and DCE. It is irrelevant to the DTE how the data is passed on from the DCE to the network and then forwarded between the PSCs.

- Packet assembly/disassembly facility (PAD)

The PAD is for connecting character-oriented, asynchronous DTEs, e.g. start/stop terminals, to a PSDN. These DTEs send the data to be transferred character by character to the PAD. The PAD sets up and clears down the X.25 connection. It collects the data of the DTE and splits it into packets. When the PAD receives packets from the PSDN for the character-oriented DTE, the PAD thus transfers the data of the packet character by character to the DTE.

A character-oriented DTE can also be connected to a PAD via a circuit switched network

Data Terminal Equipment (DTE)

The following DTEs can be connected to a PSDN.

- Packet-mode DTEs

- central host computers consisting of front-end processor and host computer with peripherals
- central host computers consisting of a Communications Controller or integrated front-end processor and host computer with peripherals
- terminals with optional ancillary equipment (e.g. hardcopy, ID card reader)
- personal computers (PCs) appropriately equipped

- Character-oriented DTEs

Character-oriented DTEs can be connected via a PAD to a PSDN.

Character-oriented DTEs are start/stop terminals (asynchronous stations) which interrupt the data flow after each character (or group of characters) during the output or transfer of data. Data transfer between DTEs and PADs is asynchronous. One example of a character-oriented terminal is the PC.

2.3.4 Frame relay networks

Characteristics

The switching principle for frame relay is the same as for packet switching, i.e.:

- Data is exchanged via virtual connections.
- The virtual connections are processed via Data Link Connections (logical channels).

However, in contrast to the actual packet switching technology, no real packeting (i.e. splitting of data to be transmitted into packets) occurs when using frame relay.

Since frame relay technology uses transmission media that are capable of higher transmission speeds and better quality, the protocols used can be simplified, thus resulting in much better throughput than traditional packet switching.

Communication partners

The communication partners for frame relay can be any data terminal equipment (DTE) or router that is capable of handling frame relay. Such routers are often used to combine several LANs via a frame relay network.

Protocols

The frame relay protocol has been standardized in the CCITT Recommendation Q.922, Annex A, and in the ANSI Standard T1.6ca:DSS1. Protocol encapsulation using frame relay (i.e. the multiplexing of multiple protocols via a virtual connection) is defined in RFC 1490.

The LMI protocol (Local Management Interface) was developed by the Frame Relay Group: Frame Relay Specification with Extensions, Revision 1.0, 1990, Digital Equipment Corporation, Northern Telecom, StataCom.

Data network

A DTE or router can be:

- connected directly (via a dedicated line) to a frame relay network
- directly linked with another DTE that is capable of frame relay
- linked with a router that can handle frame relay

The data exchange between the communicating DTEs/routers is handled via a virtual connection. The concept of a virtual connection is described in the section “Virtual connection” on page 12.

Data Link Connections (logical channels)

A Data Link Connection (DLC) provides a logical link between a DTE/router and a frame relay switch. A DLC implements a virtual connection with the network on the physical port of a communication partner. A virtual connection is represented by a DLC on each of the two physical ports that use it. The number of DLCs must be agreed with the network provider.

Data Link Connections are identified on the physical ports of a frame relay network by the so-called Data Link Connection Identifiers (DLCIs). In other words, a DLCI is assigned to a virtual connection on each physical port. This DLCI identifies the virtual connection only at that port; the DLCIs of a virtual connection on the ports of the two communication partners are usually different.

DLCIs 16 to 1007 (and also the DLCIs 1024 to 64511 for extended addressing) can be used for virtual connections. The remaining numbers in the range 0 to 1023 or 65535 are reserved for special purposes. The used DLCIs must be agreed with the network provider.

The possible values for the WAN-FR profile are 16 to 1007. Note that only permanent virtual circuits (PVC) are supported in this case.

Committed Information Rate (CIR)

Every virtual connection is assigned a specific transmission rate called the Committed Information Rate (CIR). The CIR for PVCs must be agreed with the network provider. The Committed Information Rate may be exceeded if the additional load can be handled by the capacity of the network.

Any overloading that may occur in the network is usually handled on the network side by the following measures: Congestion Avoidance and Congestion Management. To begin with, the participants are instructed to comply with the agreed transmission rates, i.e. to reduce the rate of transmission. If the situation worsens, some data frames may be discarded by the network. The frames of virtual connections that do not maintain their transmission rates are discarded first.

Local Management Interface (LMI)

The frame relay network uses the optional link management protocol (LMI) to inform a frame relay DTE of the line status, the configuration and the status of PVCs on a certain connection from the viewpoint of the network.

Criteria for connection to a frame relay network

Frame relay networks are interesting for the following reasons:

- Performance
 - Frame relay technology achieves much higher transmission rates than X.25, since a Committed Information Rate (CIR) of up to 2 Mbit/s can be agreed upon for each virtual connection.
 - Frame relay is particularly suitable for applications with short-term peak loads, since the contracted CIR may be exceeded in cases where the overall load can be handled by the network (“bandwidth on demand”).
 - One of the reasons why higher transmission rates are possible with frame relay than with X.25 is because less protocol information needs to be transferred.
- Cost
 - The tariff structure for the public frame relay network (in Germany) is independent of the distance.
 - Since a main line can be used for a number of connections, there are no costs for multiple connections.
 - The resources of a frame relay network are shared by all participants and thus used in a cost-effective manner.
- Availability
 - The availability of PVCs is very high.
 - Malfunctions and failures can be circumvented by taking the appropriate steps to define alternative routes in the frame relay network.
 - Congestions are avoided by Congestion Management. This ensures a high degree of operational reliability.

- Accessibility
 - Frame relay networks are offered in some European countries and in the USA.
 - The standardization of interfaces allows DTEs from various vendors to be linked.
 - The protocol encapsulation option defined in RFC 1490 increases the accessibility of a UNIX system with a frame relay connection.

Structure of a frame relay network

The basic structure of a frame relay network differs from that of a packet switching network only with respect to the lack of a packet assembler/disassembler (PAD). A frame relay network consists of:

- frame relay switches (switching centers, nodes).
- main lines with Data Link Connections (logical channels).

Each DTE/router has a main line to a node in the network. This node serves as the data circuit-terminating equipment (DCE) for the DTE/router. For more information on the concepts of a switching center, main line, and data circuit-terminating equipment, see the section “Structure of a packet switching network” on page 15.

Data Circuit-terminating Equipment (DCE)

The DCE is the frame relay protocol partner of the DTE or router. This means that the frame relay protocol controls the data transfer between the DTE/router and the DCE. The method by which data is forwarded from the DCE to the network and then transmitted between the switching centers is of no consequence to the DTE.

Data Terminal Equipment (DTE)

The following DTEs can be connected to a frame relay network if they are equipped to handle frame relay:

- A central host consisting of a front-end processor (FEP) and a host computer with peripherals.
- A central host consisting of a Communications Controller (CC) or integrated front-end processor (FEP) and host computer with peripherals.
- A Personal Computer (PC) with the required hardware.

The concepts of a switching center, main line, and DTE are described in the section "Structure of a packet switching network" on page 15.

Public frame relay network

In the Federal Republic of Germany, there are networks which can handle both X.25 and frame relay. These networks were set up across the entire country and satisfy the requirements of the CCITT Recommendation Q.922, Annex A.

Direct access to a frame relay network

When a DTE is linked to a frame relay network directly, it is connected via a dedicated line to its local frame relay switch (DCE). All virtual connections of the DTE to a remote DTE are handled via this switch. The link can only be used for frame relay connections.

DTE transmission speeds

It is possible to connect DTEs with different transmission speeds to a frame relay network. If two DTEs with different transmission speeds want to exchange data, the network adapts the transmission speeds as required.

At present, DTEs with transmission speeds of $n \times 64000$ bit/s ($n \leq 15$) can be connected to the public frame relay networks, such as those of Deutsche Telekom.

2.4 User facilities of a dedicated line interface

In the context of WANs, CCP-WAN supports the use of the connection types V.24, X.21bis, X.21 and V.35/V.36 for dedicated lines.

In the case of V.24 dedicated lines, direct connection without using a modem is possible. Both of the terminals create the send rate for its partner. A special direct connection cable is necessary for this.

Multilink

The Multilink function is supported for NEA protocols in accordance with IS 7478 (sorted) for X.21/V.24 dedicated lines. This function enables an increase in the transmission bandwidth between two systems by bundling parallel lines. More details can be found in the section “Bundled lines (Multilink)” on page 79.

Multipoint

Two or more terminals can be connected to one of the two end points of a dedicated line by means of interface expanders. This gives you multipoint connections instead of point-to-point connections. However, in these multipoint connections the line can only be used in half-duplex mode. The individual device functions as the primary control and the devices connected in parallel as secondary controls. Multipoint connections involve linking a primary control in a (logical) star-type network with a series of secondary controls. Communication between the controls is managed by the primary control. CCP-WAN allows your system to be used as a secondary control.

2.5 User facilities of a switched line

Connection options

Via V.24, CCP-WAN enables connections to modems by means of either manual dialing, predefined call numbers or automatic dialing in accordance with V.25bis. This enables you to use analog telephone networks, e.g. the public telephone network.

CCP-WAN enables connections to the ISDN network via terminal adapters with automatic dialing in accordance with X.21.

2.6 User facilities of the X.25 interface

This section describes some of the CCITT Recommendations for packet switching. In addition, the most important concepts of CCITT Recommendation X.25 are explained, as well as some of the resultant facilities in X.25 networks that it supports. A distinction is made between functions offered by the packet layer and those known as facilities. Facilities are optional.

2.6.1 Packet switching protocols

A data transmission control procedure is used to regulate data exchange between two DTEs. Such a procedure is also called a *protocol*.

Standardization of protocols

Since there are usually different types of DTE connected to a network, the protocols used must be standardized. There are vendor-specific protocols which ensure that all the systems from a particular vendor are compatible. These standards are not suitable, however, if networks are to be set up for systems from different vendors. In order to achieve compatibility between different systems, international standardization bodies have laid down guidelines governing the architecture of data networks and the protocols used for data exchange.

The following CCITT Recommendations apply to packet switching networks:

- X.25 for the direct connection of packet-mode DTEs to a PSDN
- X.3, X.28, and X.29 for the connection of character-oriented DTEs to a PSDN
- X.31 for the connection of a packet-mode DTE to a PSDN via an ISDN
- X.32 for the interconnection of a packet-mode DTE to a PSDN via a CSDN or switched telephone network
- X.75 for international networking of PSDNs

The following ISO standards apply for packet switching:

- IS 7776 Description of the protocol for layer 2 (HDLC-LAPB)
- IS 8208 Description of the protocol for layer 3

Connection to a PSDN - Recommendations X.25, IS 7776, and IS 8208

The ISO has defined the OSI Reference Model as the basis for network architecture. This model is used in turn as the basis for the recommendations for packet switching published by the CCITT (International Telegraph and Telephone Consultative Committee).

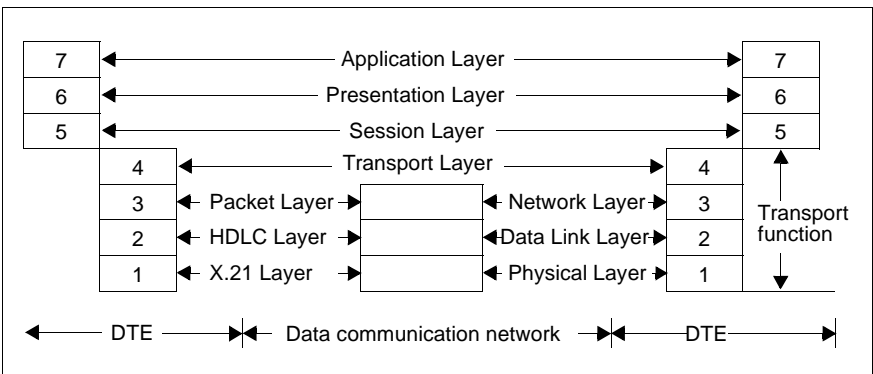

Figure 3: OSI Reference Model and CCITT Recommendation X.25

The CCITT Recommendation X.25 standardizes the transfer of data between a DTE and the DCE of a PSDN. It covers layers 1 to 3. The X.25 protocol between the DTE and DCE is not symmetric, i.e. the protocol elements passed from the DTE to the DCE are slightly different in structure from those that are passed from the DCE to the DTE, and the flow of processing at the DTE and DCE is not identical. The following CCITT Recommendations have been published: 1980 (Yellow Book), 1984 (Red Book), and 1988 (Blue Book); see "CCITT

Yellow/Blue/Red Book” [7]. The most important recommendations have also been translated into German (see “CCITT Recommendations” [8]). A detailed description of X.25 concepts can be found in the section “X.25 concepts” on page 27.

The ISO standards IS 7776 and IS 8208 describe the protocols of layer 2 and layer 3 for packet switching. These ISO standards are essentially similar to the CCITT Recommendation X.25. They differ from the X.25 Recommendation only in the viewpoint taken. In X.25, packet switching is viewed from the network, while in the ISO standards it is viewed from the DTE.

The ISO standard IS 8208 includes a supplement to the X.25 protocol for layer 3, which describes the DTE-DTE link via a circuit switching network.

Connection to a PSDN via ISDN - Recommendation X.31

Recommendation X.31 describes the interconnection of a packet-mode (X.25) DTE to a DCE of a PSDN via an ISDN. X.31 standardizes the functions of a terminal adapter in the ISDN, which provides an X.25 interface for a packet-mode DTE.

International networking - Recommendation X.75

To enable PSDNs to be linked in international networks, the CCITT has defined Recommendation X.75.

The X.75 control procedure regulates data exchange on international circuits between PSDNs.

2.6.2 X.25 concepts

X.25 defines the interface between data terminal equipment (DTE) and the associated data circuit-terminating equipment (DCE) for packet switching.

The X.25 interface consists of three layers:

- **Physical level**

This controls physical data transmission and is defined by Recommendation X.21. The V.24-compatible interface X.21bis is also available.

- Recommendation X.21:

X.21 defines the electrical characteristics of a bit-serial, synchronous, full-duplex, point-to-point connection for digital transmission.

- Recommendation X.21bis:

The X.21bis variant is a recommendation which allows connection to a network via a V.24 interface.

- **Link level**

Level 2 defines the structure of the data to be transmitted in the form of HDLC frames and describes the control procedure for exchanging HDLC frames between the DTE and the DCE. The link level is essentially concerned with guaranteeing error-free data transfer.

- HDLC frame (HDLC):

The data and control information are transferred in the form of HDLC frames. An HDLC frame contains either control information only or control information and data.

- The HDLC-LAPB control procedure:

The link level (level 2) uses the ISO standard protocol HDLC-LAPB (High Level Data Link Control Balanced) as the control procedure. This is a protocol that governs data exchange between two peer stations and guarantees practically error-free data transfer. Both sides act as a combined primary and secondary control. They have access to the same commands and messages and can send commands and messages at any time.

● Packet level

Level 3 defines the structure of the data to be transmitted in the form of packets, and describes the connection concept and the control procedure for exchanging the packets between the DTE and the DCE. The functions of the packet level are as follows:

- breaking down and reassembling user messages
- multiplexing a number of virtual connections on the data link at link level
- setting up and clearing down virtual calls
- data transfer and data flow control
- restarting after reset or restart requests
- error detection
- provision of additional functions offered by network providers as optional services

This definition therefore provides a framework for regulating the way in which users transfer data and control information to the interface, or accept data and control information from the interface. There is no provision for ensuring that data will arrive at the DTE for which it is intended.

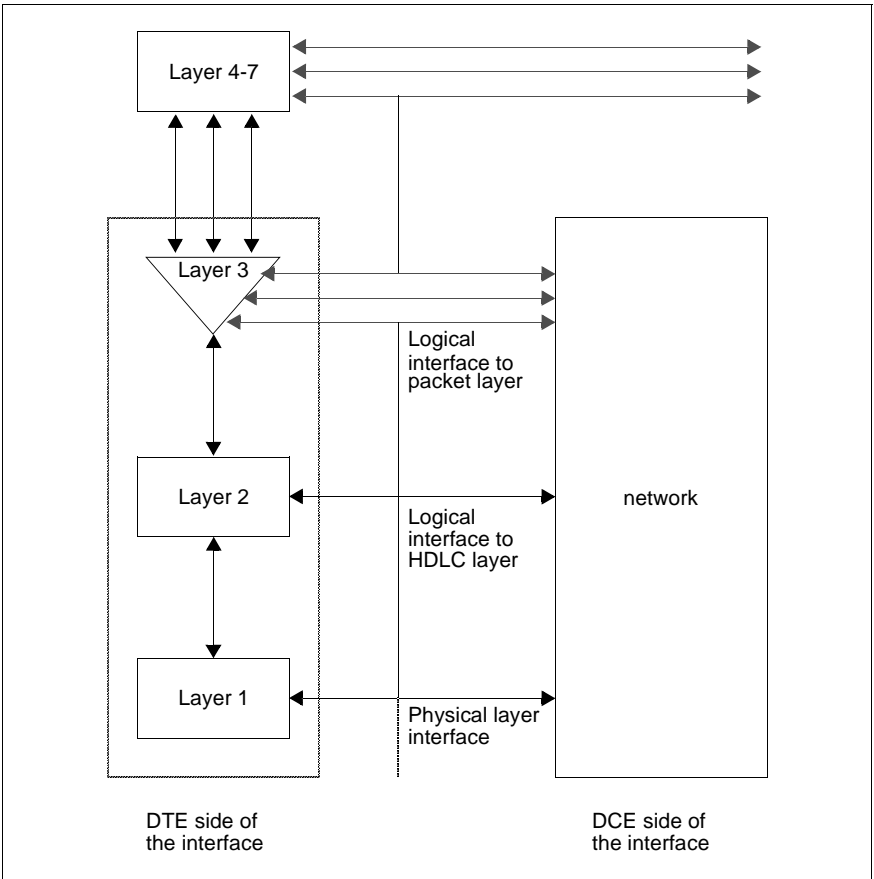

Figure 4: Layers of the X.25 interface

2.6.3 Functions at the packet level

Communication at packet level

Communication at the packet level takes place between two DTEs linked via a virtual connection. A distinction must be made as to whether communication is to take place via a switched virtual call (SVC) or a permanent virtual circuit (PVC):

- In the case of an SVC, a connection must first be set up. When the connection has been set up, data transfer can take place. The connection must then be cleared down again.
- For a PVC, there is no connection setup or cleardown, since the connection is permanently in place. Data transfer can take place at any time.

One logical channel from each of the two DTEs is used to establish a virtual connection. The channel number is included in the exchanged packets, so that the packets belonging to a particular connection can be clearly identified. The channel number consists of the channel group number and the number of the channel within the channel group. The most important stages in each of the phases are described below.

Setting up a switched connection

- The sending DTE searches for a free logical channel via which the call is to be handled; as high a channel number as possible is used in order to avoid call collisions. When it has found a free logical channel it sends a *connection request* packet to the DCE. The DCE forwards the connection request to the network.
- In the PSDN, a connection is set up to the DCE responsible for the remote DTE. The relevant DCE is established with the aid of the data call number of the target DTE specified in the connection request. The remote DCE selects a free logical channel of the target DTE for the call, this time looking for as low a channel number as possible in order to avoid call collisions. When it has found a free channel, it sends an *incoming call* packet to the target DTE.
- The target DTE accepts the call with a *call accepted* packet.
- The remote DCE transfers the information to the network which forwards it to the DCE of the sending DTE.

- The DCE of the sending DCE sends the *call connected* packet to the sending DTE. The SVC is now set up and the two selected logical channels are reserved for the duration of this SVC.

Connection setup may be unsuccessful for a number of reasons. For example, there may be collisions because a logical channel is already occupied. The remote DTE may also reject connection setup for a variety of reasons.

Data transfer

Each of the two DTEs linked via a virtual connection can send and receive packets for data transfer and flow control. The user data in the packets is transported through the network unchanged. The sequence of bits in the data packets remains unchanged. The data packets are received in the same order in which they were sent.

Clearing down a switched connection

An SVC can be cleared down either by a DTE or by a DCE; a DTE uses the *clear request* packet, while a DCE uses the *clear indication* packet.

The operations involved when a DTE clears down a call are as follows:

- A DTE sends a *clear request* packet to its DCE.
- The DCE confirms cleardown with the *clear confirmation* packet. The DCE responsible for the remote DTE is also notified of the cleardown.
- The DCE of the remote DTE sends a *clear indication* packet to the remote DTE.
- The DTE confirms the cleardown with a *clear confirmation* packet. The SVC then ceases to exist. The logical channels involved are free again and can be used for new connections.

Packets which are still being transmitted when an SVC is cleared down (e.g. packets sent by the remote end) are lost.

2.6.4 Optional user facilities in X.25 networks

In addition to the functions described for the packet level, Recommendation X.25 defines a number of optional user facilities which the user can select as required.

These user facilities can be grouped in the following three categories:

- user facilities offered by the network
- user facilities that are defined at generation time
- user facilities that are defined at generation time and can be specified at connection setup

The user facilities are optional and extend beyond the minimum requirements of the X.25 protocol. Not all PSDNs have to provide all facilities. The description below covers the user facilities offered by the CCITT 84 Recommendation and supported by CCP-WAN via WAN-MULTI. Ask the responsible network provider about the user facilities implemented in your PSDN.

The settings for the facilities described below can be made most easily using the character-oriented user interface *CMXCUI*.

User facilities offered by the network

These user facilities must be defined with the network provider, either when setting up a main line to a PSDN or via an update request. CCP-WAN offers the following facility:

- Closed and bilaterally closed user group

A closed user group means that only members of that group can communicate with each other, i.e. a DTE which belongs to a specific user group can only set up connections to a DTE of the same user group. A DTE can belong to more than one user group. The closed user group facility makes it possible to form a closed user network within the PSDN in order to protect data. A *bilaterally closed user group* is a closed user group to which only two DTEs belong.

It is also possible for a DTE to define a user group with outgoing or incoming access. In this case the DTE concerned is permitted:

- to send connection requests to a DTE outside the user group (outgoing access), or
- to accept an incoming call from a DTE outside the user group (incoming access).

User facilities defined at generation

At generation, the following user facilities can be assigned to an X.25 main line or to connections specific to DTEs. These must be agreed with the network provider.

- One-way channels

Logical channels are assigned to an X.25 main line. The number of channels corresponds to the number of virtual connections to this line which can exist at the same time. All the logical channels are divided into a domain for PVCs and a domain for SVCs. The domain of the channels for SVCs can be subdivided into channels which permit incoming and outgoing calls, and *one-way channels*. A virtual connection can be set up in one direction only on a one-way channel (incoming or outgoing).

Together with the network provider, you must define the number of logical channels of the main line, and the channel number domains for PVCs, SVCs, and one-way channels.

- Non-standard packet lengths

The default packet length is 128 bytes.

With this user facility it is possible to define an initial packet length for data packets which is different to the default length. The initial packet length specifies for the main line the maximum permissible length per data packet of the user data field. The initial packet length can be defined separately for each direction of transmission.

You can define packet lengths of between 16 and 1024 bytes (power of 2).

- Non-standard window sizes

The window size specifies the number of unacknowledged packets which may be sent to or received from the remote DTE. You can define a different window size for each direction of transmission.

The default window size is 2.

- Reverse charging acceptance

If this user facility is provided, all incoming calls in which reverse charging is requested are forwarded from the DCE to the DTE.

- Extended packet sequence numbers

With this user facility you can extend the sequence number P(S) of packets in the send direction and the sequence number P(R) of packets in the receive direction in modulo 8 (default value) through modulo 128.

User facilities specified at connection setup

The following user facilities can be specified when an SVC is set up, provided they are defined at generation.

- Closed user group

If the DTE belongs to one or more closed or bilaterally closed user groups, at connection setup you can define the user group in which the connection is to be established.

- Reverse charging acceptance

Reverse charging acceptance by the user whose DTE is called at setup is requested. The called DTE can accept or reject reverse charging.

The *reverse charging acceptance* facility must be configured for both DTEs for connection setup. In the calling DTE, *request for reverse charging acceptance* must be configured for the connection. In the called DTE, *reverse charging acceptance* must be configured for the connection.

- Sending and receiving single packets - Fast Select

Single packets are best suited for exchanging small volumes of data. With this user facility, the data is exchanged in packets for connection setup and clear-down.

If a DTE has defined the *send single packets* facility at generation, it can use an extended *connection request* packet. In an extended connection request packet, the user data field (call user data) is 128 instead of 16 bytes long. The data to be transferred is entered in this field. The packet is forwarded to the remote DTE by the DCE (remote DCE) responsible for the remote DTE if this has defined the *accept single packets* facility at generation. If the remote DTE has not defined this user facility, the connection request is rejected by the remote DCE. If the user facility has been defined, the incoming call is transferred to the remote DTE with the extended user data.

The called DTE can react in two ways:

1. The remote DTE responds to the incoming call with an extended *call accepted* packet (length of user data field = 128 bytes). The called DTE can then clear down the connection with a *clear request* or use the connection to exchange data packets. If the DTE clears down the connection, it can use 128 bytes for user data in the *clear request* packet.
2. The remote DTE responds to the call with a *clear request* packet only (containing up to 128 bytes of user data).

- Throughput class agreement

An initial throughput class is defined for all of the switched virtual calls (SVC) of a connection. The initial throughput class can be revised for each individual SVC during the connection setup phase, provided the facility *throughput class agreement* has been defined by the DTE.

- Flow control parameters agreement (window size, packet length)

Flow control parameters include the size of the DTE send and receive windows, and the maximum permissible packet length (which can also be defined individually for each direction of transmission). If the facility *flow control parameters agreement* is configured for a DTE, the flow control parameters can be negotiated and selected during the connection setup phase of the corresponding SVC.

2.7 Features of the frame relay interface

This section describes the CCITT Recommendation Q.922, Annex A, for frame relay. It also explains the most important concepts in the Recommendation and some of the features resulting from it. The concept of “Protocol Encapsulation” in accordance with RFC 1490 is also discussed here.

2.7.1 Protocols for frame relay

Frame relay is defined in the following CCITT Recommendation and in the equivalent ANSI Standard (also listed below):

- Q.922, Annex A, for directly connecting DTEs that are equipped for frame relay to a data network.
- ANSI T1.6ca:DSS1 for directly connecting DTEs that are capable of frame relay to a frame relay network.

Both standards describe a protocol of the OSI Layer 2 (Data Link Layer) and are identical.

The following documents are also significant:

- RFC 1490, which describes protocol encapsulation using frame relay.
- LMI Rev. 1, the link management protocol of the LMI group.

Connecting to a frame relay network

The CCITT Recommendation Q.922, Annex A, governs the exchange of data between a DTE and a DCE of a frame relay network. It covers only Layer 2.

The frame relay protocol is essentially symmetric, i.e. the protocol elements sent from the DTE and the DCE are identical in format. However, the program flows in the DTE and DCE differ to some extent.

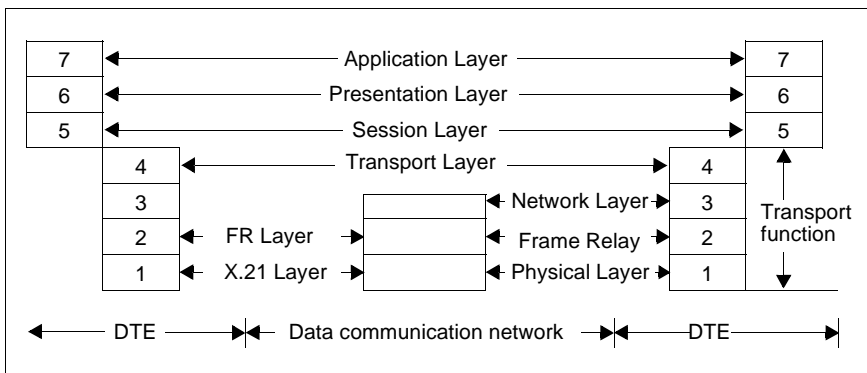

Figure 5: OSI Reference Model and CCITT Recommendation Q.922, Annex A

2.7.2 Frame relay concepts

The frame relay interface consists of two layers:

- Physical layer

This layer governs the physical transmission of data. Many private frame relay networks as well as the public frame relay network provide the X.21 interface at this layer.

Recommendation X.21:

X.21 describes the electrical characteristics of a bit-serial, synchronous, duplex, point-to-point connection for digital transmissions.

Frame Relay can be run with the V.24 interface.

- Link layer

Layer 2 defines the structure of the data to be transmitted in the form of frames and the control procedure by which frames are exchanged between the DTE and the DCE. The individual functions of the link layer for the frame relay service are listed below:

- Data transmission (as data frames).
- Error detection (i.e. the detection and discarding of invalid frames).
- Multiplexing of multiple virtual connections on the transmission segments of the link layer.

- Congestion avoidance and burst management.
- Restart and reset requests.
- Protocol encapsulation in accordance with RFC 1490 (optional).

This definition thus provides a framework which governs how the DTE and DCE hand over or accept data to and from the interface. It does not guarantee that the data will actually arrive at the DTE for which it is intended.

The optional local link management provides the following functions if appropriate:

- periodic information about
 - the status of the frame relay interface
 - configuration of the PVCs at this interface from the viewpoint of the network
 - status of the PVCs at this interface from the viewpoint of the network
- local deactivation of PVCs, which have become inactive or have been deleted from the network configuration from the viewpoint of the network

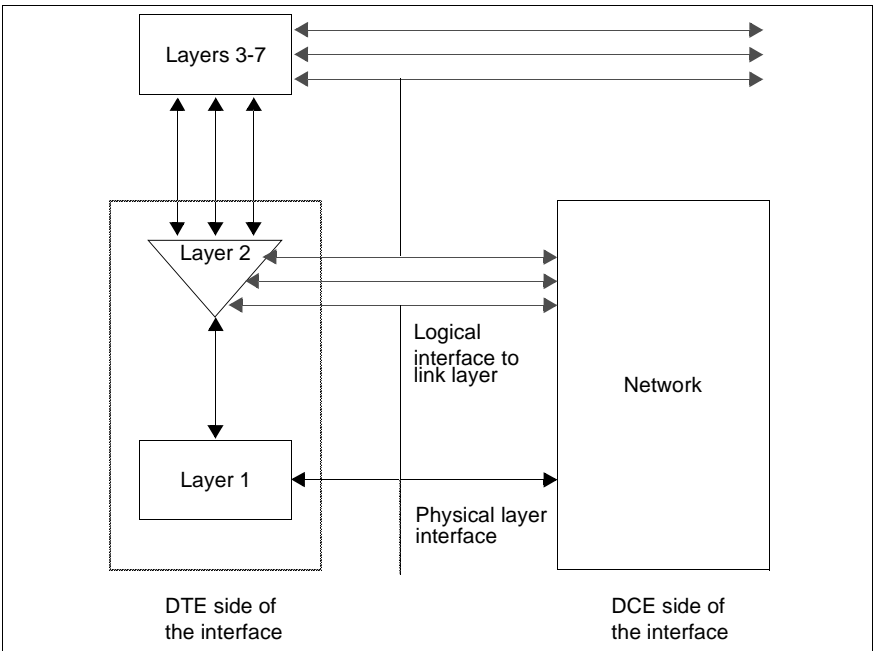

Figure 6: Layers of the frame relay interface

2.7.3 Functions at the link layer

Communication on the link layer and higher layers

Communication on the link layer occurs between frame relay terminal devices (DTE) or routers and frame relay switches. In general, a DTE or router communicates on the link layer with a frame relay switch; however, it is also possible to have direct communication between two DTEs on the link layer.

Higher layers in a DTE/router communicate via frame relay PVCs, which are provided by the link layer (layer 2). Each of the participating DTEs/routers use a DLCI (Data Link Connection Identifier = PVC number) for processing PVCs. A DLCI identifies the PVC on a transmission segment. Note that two DTEs will generally use different DLCIs for the same PVC. DLCIs are assigned by the network provider.

Data transfer and error detection

Each of the two DTEs/routers that are linked to one another via a virtual connection can send and receive data frames. If no transmission errors occur, the user data in the frames is transferred without changes, i.e. the sequence of bits in the frames and the sequence of the frames themselves are not altered during the transmission.

If frames are corrupted during the transmission, such errors are detected, and the corrupted frames are discarded. In such cases, the corrupted frames are lost.

One of the characteristic features of frame relay (in contrast to packet switching using X.25) is therefore the following:

Higher layers of the OSI reference model that make use of the frame relay service must independently ensure that the frames lost during transmission are repeated.

This should not, however, be construed as a weakness of frame relay technology. Given the high quality of the transmission media that is possible today, the overhead required to ensure data integrity (i.e. guarantee an error-free transmission) on the link layer (i.e. in the terminal devices and in each network node) and the corresponding reduction in throughput cannot always be justified. A more effective approach would be to transfer some of this overhead to the transport layer (TCP), since the overhead would then only be required in the terminal devices and not in all network nodes involved.

WAN-FR supports only PVCs (at the first implementation level).

Multiplexing PVCs on a transmission segment

The link layer in the CC can multiplex up to 992 PVCs on a frame relay connection line. The PVCs that are simultaneously active on a connection must share the transmission rate of that line.

Congestion avoidance and burst management

Congestion avoidance, congestion management, and the ability to handle short-term data bursts that exceed the Committed Information Rate (CIR) are the characteristic features of frame relay.

The following facilities, which must be agreed with the network provider and also the remote frame relay partner, are fixed for each PVC:

- The *Committed Information Rate* CIR is the transmission rate that is normally allocated to the PVC and guaranteed by the network.
- The *Committed Burst Size* Bc is the data volume (based on the CIR) that may be transmitted on a PVC in either direction in a measuring interval T. The following relationship applies: $T = Bc/CIR$.
- The *Excess Burst Size* Be is the data volume that may be transmitted on a PVC in either direction in addition to the Committed Burst Size in a measuring interval T if allowed by the network capacity. If more than Bc + Be is sent in a time interval T, some data may be lost.
- The *Maximum Transit Delay* is the maximum duration for the transfer of a frame from a DTE/router to a remote DTE/router.

The data transmission rate of a PVC is adapted dynamically to the current load situation in the network by your CC with the WAN-FR subnetwork profile: if free capacity is available, additional data may be transferred, and if congestions occur in the network, the data transmission rate is reduced. This mechanism is controlled by the frame relay protocol.

The parameters mentioned above must be specified as frame relay facilities when configuring the PVC.

Protocol encapsulation in accordance with RFC 1490 (optional)

Every PVC can be operated individually with or without protocol encapsulation, as defined in RFC 1490. This facility makes it possible to operate (higher) protocol stacks via the relevant PVC independently of one another (simultaneously or in succession). The protocol encapsulation facility needs to be agreed upon only with the remote partner.

Only the TCP/IP protocol stack can be operated via the WAN-FR subnet profile.

Relative priority of a PVC at the local port

The relative priorities of the PVCs of a frame relay connection to a CC can be used to control the order in which the frames of different PVCs in the output queue of the local port are handled. This parameter is only significant locally.

The Local Management Interface (LMI)

You have the option of using a link management protocol (in agreement with the network provider) for a frame relay interface at which only permanent virtual connections (PVCs) are operated. The most widely-used link management protocol is LMI Rev. 1, which has been implemented in CMX/CCP 5.1B.

A frame relay DCE uses the link management protocol to inform a frame relay DTE of the PVCs that have been configured in the network and what their status is from the viewpoint of the network. The DTE monitors the status of the frame relay interface by monitoring its "heartbeat":

The DTE sends a status request signal to the DCE at regular intervals. The acknowledgment provides information on whether the frame relay interface and network are intact.

If the heartbeat monitoring process detects an error in the frame relay service, frame relay communication (at the connection involved) is interrupted. The monitoring of the heartbeat itself continues. Once the error has been resolved, frame relay communication is restored. An error in the frame relay service or the resolving of an error generates CCP news.

The DTE issues a status request at regular intervals which requests information about the configuration and status of PVCs in the network. This allows the DTE to maintain an overview of which PVCs are currently available (at this interface). This avoids, for example, situations in which a user uses a non-existent PVC, which results in the loss of data and therefore requires subsequent recovery of the data. Changes to the status of the PVCs in the network generate news.

2.8 Point-to-point protocol for TCP/IP routing

CCP-WAN supports the point-to-point protocol (PPP). The point-to-point protocol is described in RFC 1171 and RFC 1172 and is a standardized method for routing datagrams (i.e. data packets via TCP/IP containing sender and target addresses) in encapsulated form.

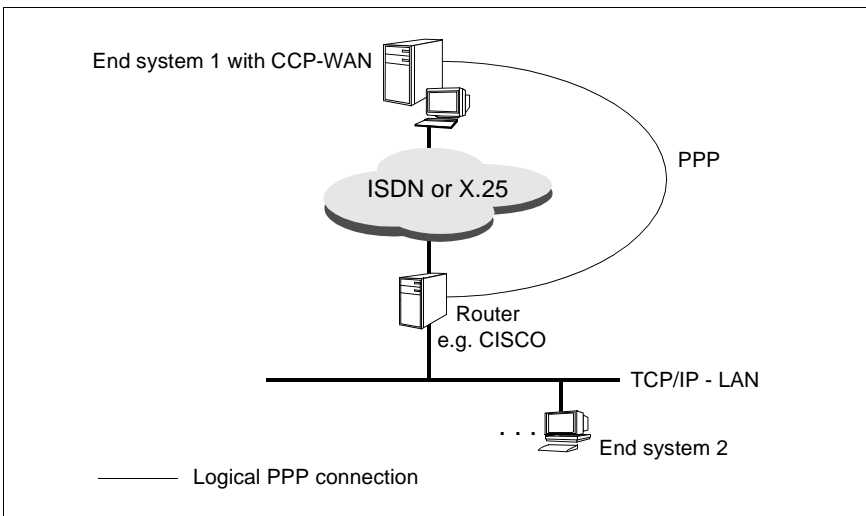

Figure 7: LAN/WAN routing uses PPP

The point-to-point-protocol (PPP) is required in many routers for communicating with other routers. If you use your UNIX system as a router, PPP enables you to communicate with CISCO, 3COM and CONWARE routers, etc.

2.9 Selecting an alternative network connection

The functionality of “selecting an alternative network connection” allows you to optimize the connectivity of your system with its partner systems in the WAN. If a line is busy or has failed, the desired connection is rerouted to an alternative connection.

Case 1: Busy or failed local connection

If a link cannot be established due to a busy line or problems with a local connection, CCP-WAN tries to establish the link via an alternative local connection.

This is only possible, provided you have configured multiple local connections of the same type and with the same subnet ID. Such connections lead to the same partners, have the same user protocols, and the same connection type, i.e. switched or permanent.

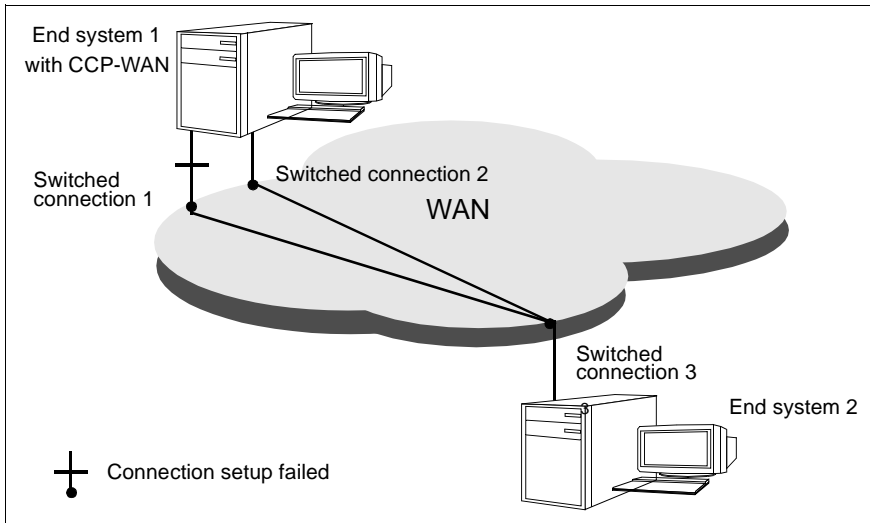

Figure 8: Use of an alternative network connection

If the connection setup via the switched connection 1 fails, your system will try to establish a link via the switched connection 2.

Case 2: Alternative route in another subnetwork

If a link cannot be established, CCP-WAN tries to set up a connection via other WAN links in the case of ports using the NEA, TCP/IP and NTP user protocols.

This will only be possible, provided you have configured multiple routes via ports in different subnetworks that lead to the same partner.

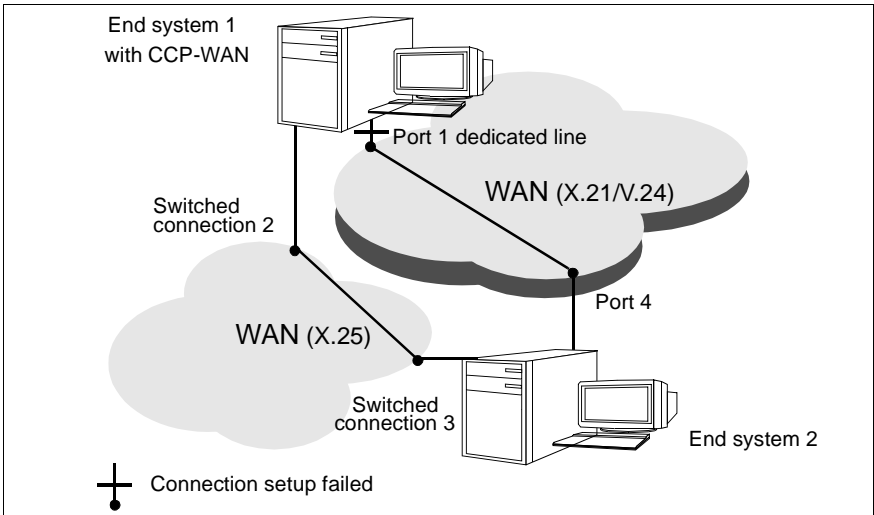

Figure 9: Alternative route in a different subnetwork

If the connection setup via the route from port 1 to port 4 fails, your system will attempt to establish a link from the switched connection 2 to the switched connection 3.

Case 3: Busy or failed partner connection

If your partner's connection is busy or has failed, and your partner has another WAN connection, CCP-WAN tries to reach the partner via that connection. This is contingent on your having defined multiple routes (SNPAROUTES objects) in the FSS for that partner connection.

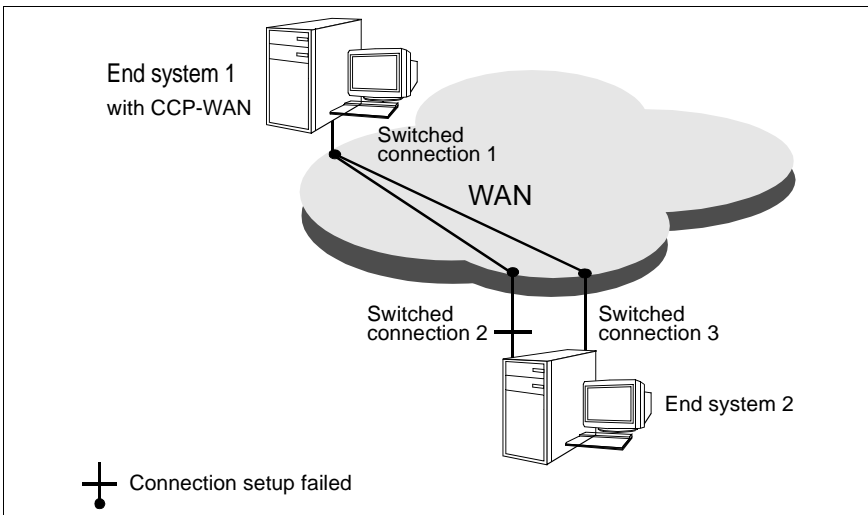

Figure 10: Use of an alternative network connection due to problems at the remote port

If the attempt to establish a link via port 2 fails, your system will try to set up the connection via port 3.

2.10 Two-step dialing to and from X.25 networks via telephone networks

CCP-WAN supports two-step dialing to and from X.25 networks via an (analog) telephone network to X.32 (hereinafter referred to as X.32 dialing). This enables a UNIX system to be connected as a packet-oriented DTE to an X.25 network via a standard telephone network.

The X.32 dialing function can be used to connect UNIX systems to an X.25 network even in cases where direct access to the X.25 network would be too cumbersome and expensive or virtually impossible for geographical reasons (e.g. if the systems are too far apart or no adequate infrastructure is available).

The following requirements must be satisfied in order to connect a UNIX system with CCP-WAN to an X.25 network using X.32 dialing:

- There must be an available port to an analog telephone network.
- The X.25 network provider must support access to X.32.

The X.32 dialing function is supported by CCP-WAN in the CCP profiles WAN-NX25, WAN-CONS (X.25 variant) and WAN-X25.

2.10.1 How X.32 dialing works

The following diagram illustrates how a two-way network link with X.32 dialing is set up to and from partner systems attached to an X.25 network.

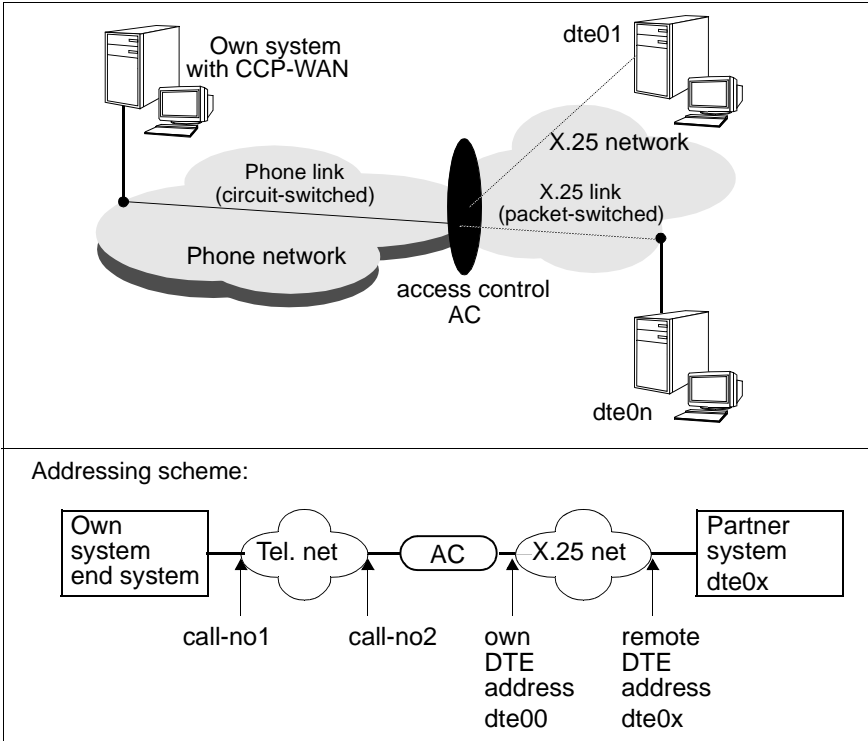

Figure 11: Communication with X.25 partners via a phone connection

The UNIX system is connected to the phone network (local call number call-no1). The X.25 connection to the X.25 partner with DTE address dte01 is set up in two stages:

1. In the first stage, a phone connection is set up via the phone network either by the UNIX system to the access unit with call number call-no2, or by the access unit to the UNIX system with call number call-no1.

On completion of the dial-up procedure, the UNIX system will be connected to the X.25 network as a packet-oriented DTE with the DTE address dte00.

2. In the second stage, a switched virtual call (SVC) is set up via the established phone connection on the basis of the X.25 protocol by either the UNIX system to the X.25 partner with DTE address `dte01` in accordance with the X.25 protocol. Alternatively, a switched virtual call (SVC) can be set up by the X.25 partner to the UNIX system with the DTE address `dte00` on the basis of the X.25 protocol.
3. Additional SVCs can now be set up via the phone connection established in stage 1 from the UNIX system to any other `dte0x` and from any `dte0y` to the UNIX system.
4. When the last SVC is cleared down, the phone connection established in stage 1 is likewise broken. This phone connection is cleared by the same side that originally set it up.

The *X.32 dial-out* function means that the phone link between the UNIX system and the access control (AS) is set up actively by the UNIX system (i.e. by an outgoing call) in the first stage of X.32 dialing.

The *X.32 dial-in* function means that the phone link from the access system to the UNIX system is set up passively (i.e. by an incoming call) in the first stage of X.32 dialing.

2.10.2 Special operational aspects

Permanent virtual circuits (PVC) cannot be used with X.32 dialing.

The calculation of charges in phone networks is time-based. In X.32 dialing, after the dial-up (or switched) connection from the UNIX system to the access control has been set up, X.25 links (SVCs) may be established via this phone link (in the reverse direction) by the systems connected to the X.25 network. Since the phone link is disconnected only on clearing the last SVC, phone charges accumulate at the UNIX system for the duration of the reversed SVCs that were set up. To prevent this from occurring, you should plan for only outgoing SVCs in the configuration for X.32 dialing. This must be agreed upon in advance with the network provider.

The ports configured for X.32 dialing are dedicated to this operating mode. It is therefore not possible to operate the CCP profiles WAN-CONS (T70 variant) and WAN-SDLC via these ports. This is due to the following reasons:

- Since (analog) phone networks do not support the transmission of the sender's call number, this cannot be used as a means of identifying the calling partner system. However, the identification of partner systems is essential in order to determine when setting up the incoming phone connection whether the setup call was initiated by a phone partner or by the X.25 access control.
- To identify partner systems via an XID exchange, a uniform procedure for the XID exchange would be required for X.32 dialing. access controls do not (usually) support the XID exchange, and only one access control can be used with the X.32 dial-in function.

The CCP profiles CCP- WAN-NX25, WAN-CONS (X.25 variant) and WAN-X25 can be operated simultaneously via the phone link (using different SVCs) established in the first stage of X.32 dialing. The assignment of the appropriate TSP (NEA, TP02, NTP) is controlled on the incoming side (in the second stage) via the Call User Data (CUD) of the Call packet, which contains information on the next-higher protocol.

A configuration example for X.32 dialing can be found in the chapter "Two-step dialing to and from an X.25 network via a phone network to X.32" on page 199.

Configuring X.32 two-step dialing for telephone lines

With CCP-WAN you can configure X.32 two-step dialing for telephone callers.

The configuration option for unknown callers with X.32 two-step dialing is valid only if access control is not active.

FSS entries

```
fssadm create SUBNET name=WAN_1_default subnet=WAN-1 x25-description=x25min
```

The SUBNET object created (WAN_1_default) specifies that the subnet profile for X.32 two-step dialing is to be set on the WAN-1 subnet connection for all incoming calls.

2.11 Access control

CCP-WAN supports a scalable system of access control for switched connections:

1. “Closed User Group” feature of the network provider
2. Subnet-specific access control
3. Directory number-specific access checks

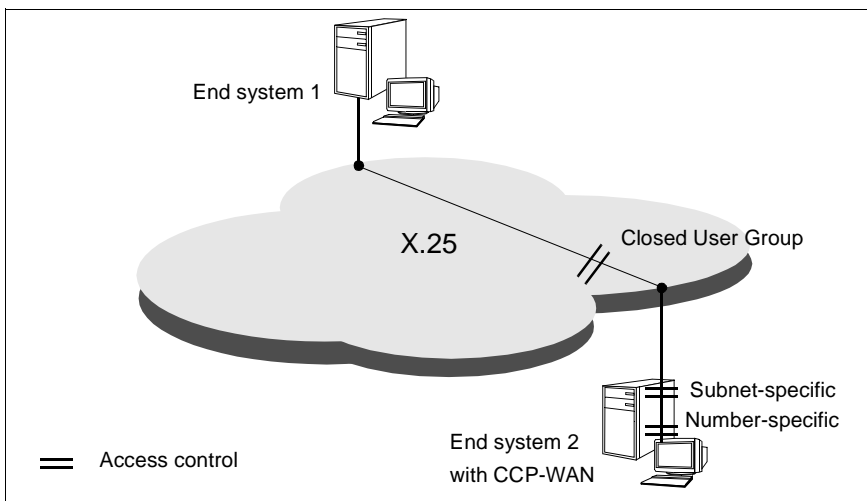

Figure 12: Access control

Closed User Group

CCP-WAN provides access control based on features of the X.25 network. The “Closed User Group” feature must be requested from the network provider and is subject to charges. Its characteristics and functionality depend on the network provider. Callers who are not members of the closed user group are blocked by the corresponding exchanges in the network. See section “Optional user facilities in X.25 networks” on page 32.

Subnet-specific access control

Access control can be applied to individual subnet connections or to virtual subnet connections representing a group of individual subnet connections. By explicitly deactivating access control, you grant access to all partners. When you activate access control, you have two options: firstly, a block for all incoming calls from the relevant subnet connection, or secondly, a check of the calling X.25-DTE address for authorization. For the latter case, directory number-specific access control must be configured.

Directory number-specific access control

The main condition for directory number-specific access control is that access control must be active on the subnet connection level. A check is run on the basis of the sender's directory number, which is sent during connection setup, to verify whether the partner is known (configured directory number). If the partner is known, a further check verifies which type of connection is permitted for this partner (e.g. incoming or outgoing). In any case, only partners for whom incoming connections are authorized are allowed access.

Attempts at access from unauthorized partners are logged together with certain information, such as the date, time and, if known, the sender address. See the description of the DEBUGFILE file in section "Diagnostic files" on page 322.

Subnet-specific and directory number-specific access control can be activated and deactivated without having to modify existing configuration files for CCs, reset subnet connections or reboot the system.



Please note that this type of access protection has no effect on existing connections during operation.

2.11.1 Examples of access control configuration

CCP-WAN provides a system of scalable access control. Access control management is offered for a variety of connections, from the subnet access (subnet accesses can also be grouped) to the individual route.

Access control must be explicitly activated, as it is inactive by default. The *incoming_call* parameter in the *SUBNET* object class in the FSS is provided for this purpose; see section “SUBNET object class” on page 287.

2.11.1.1 Subnet ID-specific block for all incoming calls

FSS entry:

```
fssadm create SUBNET subnet=X25-22 incoming_call=NONE
subnet=X25-22
    Subnet ID X.25-22
```

```
incoming_call=NONE
    Activates access control. All incoming switched connections for subnet
    ID X25-22 are rejected.
```

2.11.1.2 Subnet ID-specific block for unknown callers

FSS entry:

```
fssadm create SUBNET subnet=X25-22 incoming_call=RESTRICTED
subnet=X25-22
    Subnet ID X25-22
```

```
incoming_call=RESTRICTED
    Activates access control. All incoming switched connections for subnet
    ID X25-22 whose sender address is unknown are rejected. Only calls from
    partners whose address is entered correctly in the FSS and for whom the
    access control attribute admit has been set either with INCOMING_ONLY
    or with BOTH_IN_AND_OUT are accepted
```

FSS entries: access for known callers

If you have activated access control for your system with *incoming_call=RESTRICTED*, you must make the following entries for partners to whom you want to grant access:

1. Create a facility object with the access control attribute *admit*:

```
fssadm create FACIL name=access admit=INCOMING_ONLY
name=access
```

Name of the FACIL object

```
admit=INCOMING_ONLY
```

Only incoming calls are accepted.

If you also want an outgoing connection to partners who are to have access, use the value *BOTH_IN_AND_OUT* instead of *INCOMING_ONLY* or create an additional FACIL object for *BOTH_IN_AND_OUT*.

2. Then assign the FACIL object to the route.

```
fssadm create SNPAROUTES name=partner subnet=X25-22 dte-addr=4590255 \
facil=access
```

```
name=partner
```

Name of the SNPAROUTES object (of the route)

```
subnet=X25-22
```

Subnet ID X25-22 (You assigned this value when configuring the local WAN connection).

```
dte-addr=4590255
```

X.25 DTE address of the partner

```
facil=access
```

Reference to *access*, the previously created FACIL object. This explicitly grants access to the partner *partner* (4590255). Outgoing calls to *partner* are not permitted, since *admit* is set to *INCOMING_ONLY*.

FSS entries: checking the access control status

You can query the status of the access control at any time.

```
fssadm get SUBNET
```

This command lists all the managed SUBNET objects. Access control is active only if an object contains an *incoming_call* attribute set to *NONE* or *RESTRICTED*.

If a SUBNET object is entered with *incoming_call=RESTRICTED*, you can query the routes/partners for which access is permitted using the following commands.

```
fssadm get FACIL
```

and

```
fssadm get SNPAROUTES
```

In the above example you can enter the following command:

```
fssadm get SNPAROUTES subnet=X25-22 facil=access
```

FSS entries: deactivating access control

You can deactivate access control at any time by simply modifying the *incoming_call* attribute of the corresponding SUBNET object.

```
fssadm set SUBNET subnet=X25-22 incoming-call=ALL
```

This command means that all incoming calls are accepted for the SUBNET object *X25-22*. The *admit* attribute is no longer evaluated for any route.

2.12 Architecture of CCP-WAN

This section contains an overview of the permissible combinations of Transport Service Providers (TSPs) and subnetwork interfaces. These combinations are the so-called *CCP profiles* of CCP-WAN.

Transport protocols and services in accordance with TRANSDATA NEA (NEA), ISO class 0 and 2 (TP0/2), and the null transport protocol (NTP) are offered as TSPs. The SNA protocol can be operated under NTP.

A transport service provider (TSP) represents a specific transport protocol and the respective transport service. TSPs are implemented as STREAMS modules in the UNIX kernel. Together with the loadable network access software, they provide the full functionality of layers 1 to 4.

CCP-WAN allows you to link your system to X.21 circuit switching networks such as the telephone network, to X.25 data networks such as Datex-P, and to frame relay networks.

CCP-WAN independently handles communication tasks on a CC with multiple line ports (in your system) up to and including layer 3a (network layer) of the OSI reference model. The WAN network access software that is assigned to the CC as well as the configuration data are loaded onto the CC at system startup. This means that more than one transport service can be used simultaneously via the same CC.

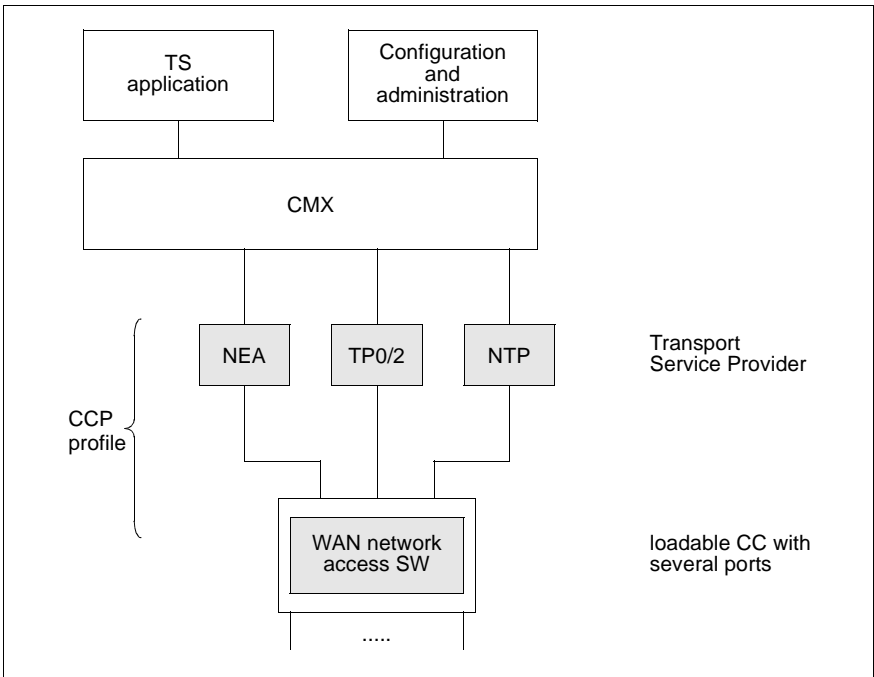

Figure 13: Implementation of TSPs and network access software

The following table shows the CCP profiles of CCP-WAN with the associated TSPs, subnet interfaces, and interface types. It also lists which packages need to be installed for the individual CCP profiles.

CCP profile	TSP	Subnet interface	Interface type	Product
WAN-NEA	NEA	CSDN telephone	NEA via HDLC	CCP-WAN-LINK CCP OSI/NEA CMX
WAN-NX25	NEA	PSDN telephone	NEA via X.25	
WAN-CONS	TP0/2	PSDN CSDN telephone	OSI via X.25 or OSI via T.70	

Table 1: Overview of CCP profiles, subnet interfaces and interface types

CCP profile	TSP	Subnet interface	Interface type	Product
WAN-X25	NTP	PSDN telephone	X.29 via X.25, SNA via X.25 or other via X.25	CCP-WAN-LINK CMX
	-	PSDN telephone	TCP/IP via X.25	
WAN-SDLC	NTP	CSDN telephone	SNA via SDLC	
WAN-FR	-	Frame relay	TCP/IP via frame relay	

Table 1: Overview of CCP profiles, subnet interfaces and interface types

3 Operating CCP-WAN

In order to work with CCP-WAN, you must complete the following steps:

- Startup of the Communications Controller
 1. First describe your local WAN connection. A menu interface is available for this purpose. CCP-WAN stores the configuration data in a configuration file (CF).
 2. Then assign the configuration file and the WAN network access software to a previously selected Communications Controller (CC).
 3. Finally, load the configuration file and WAN network access software on the Communications Controller.

- Configuration of partner systems

The next step is to enter the parameters for your partner systems and thus configure them. Partner systems are configured in the Transport Name Service (TNS) and the Forwarding Support Service (FSS). Summarized information on these steps can be found in the section "Configuring partner systems" on page 69.

Configuration examples are presented in chapters 4 - 10.

A detailed description of how partner systems are configured can also be found in the "CMX, Operation and Administration" User Guide [1].

- Entry of transport system applications

Once you have configured the partner systems, you must enter your transport system applications in the Transport Name Service (TNS) (see section "Entering transport system applications via the menu system" on page 72).

This chapter contains instructions for installation, shutdown, and deinstallation and also includes information on operating CCP-WAN.

3.1 Installation

The CMX/CCP products comprise one or more software packages in accordance with UNIX SVR4. If you have expert knowledge of the interdependencies between the packages you can install the packages separately.

CCP-Profil	Products to be installed
WAN-NEA	CCP-WAN-LINK CCP OSI/NEA CMX
WAN-NX25	CCP-WAN-LINK CCP OSI/NEA CMX
WAN-CONS	CCP-WAN-LINK CCP OSI/NEA CMX
WAN-X25	CCP-WAN-LINK CMX
WAN-SDLC	CCP-WAN-LINK CMX Additional product: Transit-Server
WAN-FR	CCP-WAN-LINK CMX

Table 2: Overview of the products to be installed

Under Solaris, the CMX/CCP software products can be installed, updated and deinstalled during normal system operation without having to reboot the system.

Installation of the CMX/CCP products always includes startup of the installed components. If the software is being updated or deinstalled, the components involved have to be shut down first. In some cases, you will have to terminate all CMX applications beforehand and, if appropriate, start them again after installation has been completed successfully.

CCP-WAN is installed using the Webstart wizard. The installation CD is automatically mounted when you place it in the drive.

- ▶ Click on one of the README icons to read the product-specific Release Notices before you start installation.
- ▶ Click on the *Installer* icon.
A welcome window is displayed.
- ▶ Click on *Next*.
A series of windows guides you through the installation procedure.
- ▶ The Installation Summary window is displayed at the end of the installation procedure. Click on Details in this window for information on whether or not installation was successful, diagnostic information, as well as information on how to proceed if an error occurs.

3.2 Setting up the local subnet connection

Before you can start your local subnet connection, you must first configure it. This applies to both the initial startup and a restart. The initial startup takes place immediately after the installation of CCP-WAN; a restart occurs after each configuration change.

The following steps must be performed to set up the local subnet connection:

1. After installing CCP WAN, you will need to configure your local subnet connection by creating a configuration file (CF), which describes your configuration. You will find more information on this topic in the section "Creating a configuration" on page 63.
2. Assign your configuration file and the network access software to a previously selected Communications Controller (CC). This step must be carried out for the initial startup and after each configuration change. Information on this topic can be found in the section "Assigning network access software and configuration file to a CC" on page 66 and in the "CMX, Operation and Administration" User Guide [1].
3. Load the WAN network access software on the selected CC: the assigned configuration is loaded automatically. This step must also be carried out for both the initial startup and after each configuration change. Relevant information can be found in the section "Loading the WAN network access software and configuration file" on page 68.

3.3 Creating a configuration

In order to use CCP-WAN, you must first configure your communications-controller (CC). This involves describing the local WAN connection and selecting CCP-WAN characteristics. CCP-WAN saves the configured parameters in a configuration file (CF).

When loading the network access software on the selected CC, the assigned configuration file is loaded as well. This configuration file determines the operating characteristics of your WAN connection.

There are two ways of creating a configuration file:

- Configuring with the menu system (see the section "Editing configuration files with the menu system" on page 64)

The menu system functions cover all the normal application cases for the configuration.

- Configuring in expert mode by editing a KOGS source file with the configuration-oriented generator language KOGS (see the section "Editing a configuration file in expert mode" on page 65).

You must compile the KOGS source file after you have created it since it is only when the source has been successfully compiled that a loadable configuration file (CF) exists.

A configuration file created in the menu system can be edited to suit specific requirements in special cases (see the chapter „Configuration with KOGS macros“ on page 223). A configuration file created in expert mode cannot be changed later in the menu system.



We recommend that you proceed as follows when creating a configuration file in which special cases need to be taken into account:

- Start by creating a KOGS source file with the menu system.
- Create a copy of this file.
- Then modify the copy to your requirements by editing the existing KOGS macros. More information on modifying a configuration file with a text editor is provided in the chapter „Configuration with KOGS macros“ on page 223.

3.4 Editing configuration files with the menu system

The menu system for editing configuration files provides you with an FMLI-oriented user interface.

The menu system enables you to perform all the activities involved in editing a configuration file. You can, for example, create new configuration files, modify or delete existing ones, or create a backup copy.

You access the menu system

- via the CMXCUI command.

General instructions on the menu system (CMXCUI) can be found in the “CMX, Operation and Administration” User Guide [1].

3.4.1 Access to the menu system via the CMXCUI command

If you are using the menu system, proceed as follows:

1. After you call the “CMXCUI” command from the shell, the main menu of the CMX menu system is displayed.
2. Select the menu item *CFs - CCP Configuration Files...*
3. Select the *WAN* option from the *Select Network Access* menu.

This displays a window in which you can mark an existing configuration file for further processing. If you do not mark a file, it is assumed that you want to create a new configuration file. To change or create a configuration file, mark the option *Edit* or *Create* in the following window.

The following steps can then be performed by referring to the instructions in the individual menu screens. If required, you can output a Help text for each menu screen by pressing F1.

3.5 Editing a configuration file in expert mode

If the selection options of the menu system described in the previous section are insufficient, you can also create and edit a configuration file using a text editor. This is only needed for special configurations. If you are working in expert mode, you will need to be familiar with the macro language KOGS described in the chapter „Configuration with KOGS macros“ on page 223.

You access the expert mode via the user interface *CMXCUI*.

3.6 Compiling a KOGS source file

If you have created a new KOGS source file in expert mode or updated an existing one, the file must be first compiled. It is only after the compilation that a loadable configuration file is produced.

If you have created the KOGS source file with the menu system, the file created will be compiled automatically and you will not see it.

Compiling the KOGS source file with the menu system

Proceed as follows:

1. Call the *CMXCUI* command from the shell.
This takes you to the main menu of the CMX menu system
2. Select the *CFs -CCP Configuration Files...* menu item from the CMX main menu.
This displays the *Select Network Access* menu.
3. Select the option *WAN* from the *Select Network Access* menu.
This displays a window in which you can mark an existing KOGS source file for further processing.
4. Mark the desired file.
This displays the menu *Operations on CFs*.
5. Select the menu entry *Compile*.

If errors occur during the compilation, they are displayed on the screen. You can then correct the corresponding entries in the KOGS source file and restart the compilation process.

3.7 Assigning and loading the configuration file

After the KOGS source file has been created and successfully compiled into a configuration file, you should

- assign the network access software and the configuration file to a CC.
- load the WAN network access software and the configuration file.

3.7.1 Assigning network access software and configuration file to a CC

After selecting a Communications Controller, you must assign the WAN network access software and a configuration file to it.

If more than one CC is being operated, you must select the network access software and the corresponding configuration file for each CC and then assign them to their respective CCs.

Once the configuration file and WAN network access software have been assigned, they are automatically loaded and started at each system startup, thus avoiding the need for an explicit start.

You can use either the menu system (CMXCUI) or administration commands to assign the WAN network access software and the configuration file.

Assigning with the menu system

Proceed as follows:

1. Call the *CMXCUI* command from the shell.

This takes you to the main menu of the CMX menu system.

2. Select the *CCs - Communications Controller...* menu option.

The *State of Communication Controllers...* menu appears with information on the corresponding CC (name and status of the CC) and on any network access software and configurations that may have already been assigned and loaded.

3. Select the desired Communications Controller (CC).

The *Operations for CC* menu is displayed. You can select various menu options here, e.g. you can load or unload the selected CC or change a configuration or switch to expert mode.

- If you wish to assign network access software and/or a configuration file, select the menu item *Change Configuration*. Enter the WAN network access software and the name of the configuration file assigned to the CC in the following menu.
- If the CC already has other network access software or another configuration file assigned to it, this network access software or configuration file must be first unloaded. Select the *Unload CC* menu option for this purpose. The WAN network access software or the configuration file should be assigned only after you have completed this step.

Assigning with administration commands

You can also make the assignment with administration commands. A detailed description of how administration commands are used can be found in the chapter “Administration and diagnostics” on page 289. The following two commands are also described there in detail.

1. After choosing the Communications Controller in the *Operations for CC* menu, select the *Enter expert mode* menu option.
2. You can then assign the WAN network access software to a CC with the *assign* command. This assignment will only take effect on loading.
3. Assign a configuration file to a CC with the *exchange* command.



When you load a configuration file on a CC, all the links on all the lines of this CC are broken. Even if you have only configured one line of the CC, all the lines of the CC are affected.

3.7.2 Loading the WAN network access software and configuration file

CCP-WAN is normally loaded when the operating system is started. Other options are also available.

Loading with the menu system

You can load CCP-WAN with the menu option *Load CC* during system operation by using the CMX menu *Operations for CC*.

Loading with administration commands in expert mode

You can load network access software together with the corresponding configuration file (CF) on a CC by using the *load* command. A detailed description of this method can be found in the chapter “Administration and diagnostics” on page 289.

If CCP-WAN is loaded on the CC, any previously loaded network access software on the same CC is stopped. Existing links are broken. If you are working in the menu system, a message will be displayed requesting you to either confirm or cancel the action.

3.8 Configuring partner systems

After the local WAN connection is configured, CCP-WAN must be provided with information on each of the partner systems that you want to reach via that WAN connection. Besides setting up the local WAN connection, this includes defining the reachable partners in the Transport Name Service (TNS) and Forwarding Support Service (FSS).

You can, for example, provide information about the remote subnetwork interface and define the route you want to use to reach the partner. These entries are administered in the CMX in the Forwarding Support Service (FSS). Entries concerning the local and remote applications and network addresses are administered in the Transport Name Service (TNS).

The configuration of partner systems is described in detail in the “CMX, Operation and Administration” User Guide [1]. The following description of the individual steps required for this purpose is only intended as a brief overview.

The required FSS and TNS entries can be made via the CMX menu options. For special cases and for mass data entry, you could, as an expert, also edit the configuration files directly.

Proceed as follows:

1. First define the route to the remote subnetwork interfaces. Information on how to use the menu system can be found in the section “Defining routes to remote subnetwork interfaces via the menu system” on page 70.
2. Then enter information about the partner system. Information on how to use the menu system can be found in the section “Entering partner systems via the menu system” on page 71.
3. Finally, enter the transport system application (see the section “Entering transport system applications via the menu system” on page 72).

For information about how to configure access control, refer to section “Access control” on page 51 and section “Entering access coe menu system” on page 73.

3.8.1 Defining routes to remote subnetwork interfaces via the menu system

First define a route to your respective partner system (remote subnetwork interface). A route is defined by means of its end points, i.e. the local subnetwork ID (also called a subnet ID or SNID) and the subnet address of the remote computer. Subnet addresses include, e.g. the DTE address in an X.25 network or the phone number in a telephone network.

If a remote computer has multiple subnet addresses or if your system has multiple connections to a subnet, there will be more than one route to that computer or your system in the same subnetwork.

Proceed as follows:

1. Select the *SNPAROUTES - Routes to Remote Subnet Interfaces...* menu option from the CMX main menu.

This displays all the existing routes.

- If the route you require is present, select it.
- If the route you require is not present, press the **[ENTER]** key to open the *Operations on Routes to Remote Subnetwork interfaces* menu option. Select the *Create* option. Enter the routing information that is needed for access to the partner system. This includes the SNPA address of the partner system and the subnet ID that defines the local SNPAs via which the partner system can be reached (see the “CMX, Operation and Administration“ User Guide [1]).
 - Enter a symbolic name for your route.
 - Enter the type of subnet address from the viewpoint of the local system. A list of all possible subnet address types is displayed if you press the **[CHOICES]** key.
 - Enter the subnet ID that describes the local subnet interface. Press the **[CHOICES]** key to display a list of all the possible values. The subnet ID that you choose here must be defined in the configuration file for the Communication Controller (CC) in the XSNID macro.
 - Enter the subnet address of the remote subnet interface.

3.8.2 Entering partner systems via the menu system

Partner systems are entered as follows:

Select the *NSAPs - Remote Hosts* menu option in the CMX main menu.

All NSAPs that are present are displayed.

- If the NSAP that you need is already present, no further steps are required for the configuration.
- Proceed as follows if you want to modify an existing entry for a remote NSAP:

Use the arrow keys to select the name of an NSAP that you want to edit. Press **MARK** and then **ENTER**. This opens a menu from which you can select *Change...*

- Press **ENTER** if the required NSAP is not present. This opens the *Operations on Remote Systems* menu. Select the menu option *Create...* . Enter the partner system network addresses (see also the “CMX, Operation and Administration” User Guide [1]). Note the close relationship between transport system applications and remote NSAPs. The name of an NSAP object must be entered as the transport address for some transport system applications. Proceed as follows to configure a network address:
 - Enter a name for the partner system (up to 32 printable characters). You will need this name later when entering the applications.
 - Enter the type of the network via which the partner system can be reached from the viewpoint of the local system (e.g. NEA, Internet).
 - Enter the NSAP address, e.g. the processor number/region number for NEA, or the Internet address for TCP/IP.
 - Enter the method by which the subnetwork address (SNPA address), which is required for routing to the partner system, is to be determined:
 - *via Intermediate System* - the partner system is reached via an intermediate system for which the SNPA address is already defined.
 - *via routing protocol* - the SNPA address is determined by means of a routing protocol.
 - *static route(s)* - the SNPA address for this partner system is specified directly.

3.8.3 Entering transport system applications via the menu system

After you have configured your local connection and the respective partner systems, you must enter your transport system application (TS application).

However, before you start entering the transport system application, you should first be familiar with the basic concepts and terms used.

A detailed description can be found in the “CMX, Operation and Administration” User Guide [1]. This section contains only an overview and a brief explanation of the individual steps in the CMX menu system.

Proceed as follows:

1. Select the *TSAs - Transport System Applications...* menu option from the CMX main menu.

This menu option is used to administer local and remote transport system applications.

2. Enter the GLOBAL NAME of the TS application. The entry of all name parts is optional. You can use the **CHOICES** function to select names that have already been defined.

3. Now enter the following entries in the *Operations on TS Applications* menu:

- Enter the local TS application first by selecting the *Assign or change LOCAL NAME...* menu option. Assign a LOCAL NAME for your desired local TS application.

Local applications have a LOCAL NAME that consists of a number of T-selectors for the various types of transport systems.

Remote applications have additional attributes such as network and subnetwork addresses and local routing information.

- A form is subsequently displayed with a corresponding field for each transport system type via which your application is to communicate. The meanings of the CCP profiles and corresponding address components are described in the “CMX, Operation and Administration” User Guide [1].
- Use the *Assign or change TRANSPORT ADDRESS* menu option to enter the remote transport system application.

- This opens a menu from which you can select the type of transport system with which the TS application is to be reached. After the transport system has been selected, a form appears in which you must enter either the complete address information or the name of an NSAP object.

This fully completes the configuration procedure for remote partner systems and transport system applications.

3.8.4 Entering access coe menu system

Proceed as follows:

1. Select the SUBNET menu option *in the CMX main menu*.
2. Press the **[ENTER]** key. The *SUBNET objects* menu then opens if objects already exist. If you want to create a new object, do not mark an object, but press **[ENTER]**.
3. The *Operations ...* menu then appears. Select the option *Create*.
 - Enter the access control information you require.
 - Specify the subnet ID which also represents the SUBNET object.
 - For the *Allowing incoming calls* option use the **[CHOICES]** key to specify whether or not you want to permit incoming calls.

DEFAULT: access control is not activated. If you are using the CS-Route product then incoming calls may or may not be permitted depending on the *admit* parameter for the corresponding route.

NONE: blocks all incoming calls

ALL: allows all incoming calls

RESTRICTED: enables you to activate directory number-specific access control
 - The specification of the *DTE name* does not affect access control.
4. If you want to activate subnet address-dependent access control (you have selected the value *RESTRICTED* for the *Allowing incoming calls* option), you must now specify the type of call that is permitted for the route: incoming calls, incoming and outgoing calls, outgoing calls or no calls. Select the menu option *SNPAROUTES - Routes to Remote Subnetwork Interfaces* from the CMX main menu.

5. A list of all the existing routes is then displayed.
 - If the route you require already exists, select it from the list.
 - If the route you require does not exist, press the **[ENTER]** key. The *Operations on Routes to Remote Subnetwork Interfaces* menu appears. Select the *Create* menu item. Enter the routing information you need to access the partner systems: the name, the type of the remote subnet address, the subnet ID, the remote subnet address (dependent on the type of remote subnetwork address, e.g. X.25 DTE address), facilities= YES (see the “CMX, Operation and Administration” User Guide [1]).
 - When you have entered all the routing information, press **[SAVE]** to save your entries.

The *Facilities to Route* window is now displayed.
 - In the *Facilities to Route* window there is an *Admission* option, under which you can specify the types of calls to be allowed: incoming calls (*INCOMING_ONLY*), outgoing and incoming calls (*BOTH_IN_AND_OUT*), no calls (*NEITHER_IN_NOR_OUT*), only outgoing calls (*OUTGOING_ONLY*) or the default value (-) *No value assigned to the parameter*.

3.8.5 Setting X.32 two-step dialing via the menu system

To set X.32 two-step dialing for a local telephone connection, proceed as follows:

1. Select the *SUBNET - Subnetwork access* menu option in the CMX main menu.
2. Press the **[ENTER]** key. The *SUBNET objects* menu then opens if objects already exist. Do not mark an object, but press **[ENTER]**.
3. The *Operations on subnet access* menu then appears. Select the option *Create*.
 - Specify the subnet ID which also represents the SUBNET object.
 - The *Admit incoming calls* must be set to *DEFAULT* if you wish to set X.32 two-step dialing. Access control must not be active.
 - Specify the name of the XZSTW macro under the *DTE Name* option. This specification refers to the KOGS file (see also section “KOGS parameters” on page 201).

3.9 Deinstallation

When CCP-WAN is deinstalled, the configuration files are retained and may be reused for a reinstallation. The configuration files that were last assigned to a CC are automatically compiled during the reinstallation.

Please refer to the Release Notice for more information on hardware and software dependencies and installation.

4 The WAN-NEA profile

4.1 Profile description

The WAN-NEA profile enables you to connect your system to a TRANSDATA network via dedicated lines, a circuit switching network or a telephone network. It allows you to use your system in a multipoint configuration as a secondary control (HDLC secondary) parallel to other secondary controls.

The WAN-NEA profile supports the Multilink function in accordance with IS 7478 (sorted) for dedicated lines on a CC.

Processor/Region numbers for NEA systems may be specified by means of placeholders, i.e. “wildcards” (*), instead of actual addresses. This method can be used to create a default route for a specific set of NEA partners (see the section “Configuring a default route” on page 80).

The NEA routing function enables your system to operate as an Intermediate System (IS) that forwards incoming NEA data packets to other NEA computers.

The following figure shows how a system is connected to a circuit switching or dedicated network when using the WAN-NEA profile:

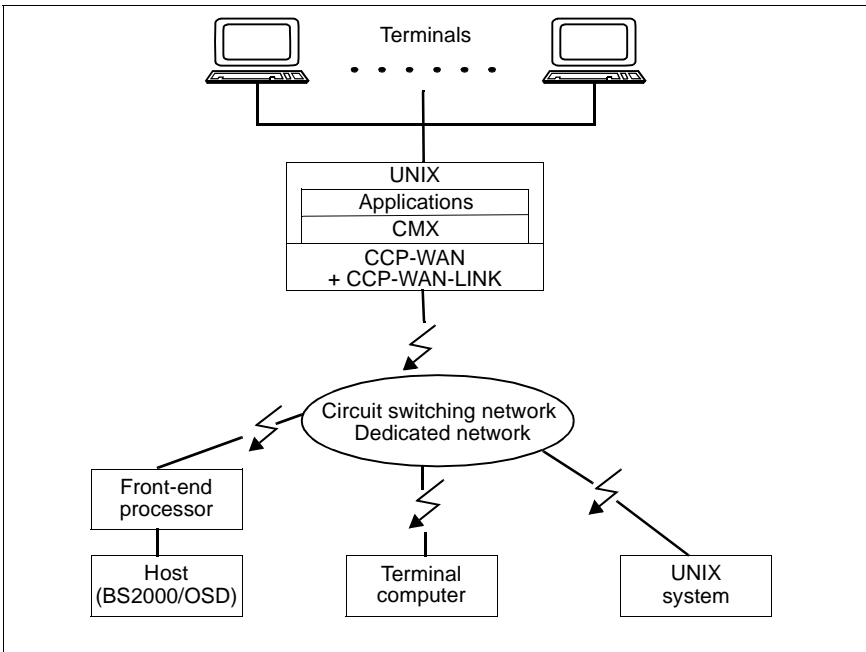

Figure 14: Connection of a UNIX system using the WAN-NEA profile

Transport system protocols

The following protocols are assigned to the layers of the transport system in the WAN-NEA profile:

Layer	Function	Dedicated line		Dial-up line	
		Point-to-point	Multi-point	Telephone network	X.21 data network
4	Transport	NEATE			
3	Network	NEAN			
2	Data Link	HDLC-BAC or HDLC-UNB	HDLC-UNB	HDLC-BAC	HDLC-BAC
1	Physical	V.24/X.21(bis)	V.24/X.21	V.24/V.25bis	X.21

Table 3: Protocols for dedicated line / dial-up networks

4.2 Bundled lines (Multilink)

The WAN-NEA profile supports the Multilink function in accordance with IS 7478 (sorted) for dedicated lines.

The Multilink function enables an increase in the transmission bandwidth, and thus in the data throughput, by bundling the lines on a CC. Apart from the higher bandwidth, this function also ensures the uninterrupted transmission of data with individual lines in the multilink fail. Data packets are distributed uniformly independently of the transport connection across the individual lines of the multilink.

Depending on the type and structure of the Communications Controller, up to four 4 X.21/V.24 dedicated lines can be bundled with the Multilink function. Optimum throughput is achieved by bundling lines with the same transmission speed. As a prerequisite, the partner system must also support the Multilink function as defined in IS 7478 (sorted).

It is not possible to operate multilinks across multiple CCs.

Seen from the viewpoint of the TSP, a multilink represents a single line that is defined by a multilink number (see the MLNK operand in the KOGS macro XLTNG). Every line of a multilink has the same subnet ID, and the individual lines that comprise the multilink cannot be used independently outside the multilink. The smallest line number of the multilink must be specified in the TNS. This line number is used by the transport system application to address the multilink.

Grouped lines

In contrast to multilinks (i.e. bundled lines), where data packets are distributed uniformly across the existing lines in the multilink, lines may also be grouped. In this case, however, only the network connections to be set up are distributed over the existing lines in a group, not the data packets themselves.

Multilinks and individual lines can be combined into a group of identical ports, even across multiple CCs. In this case, the NEA transport system treats the lines as equivalent and selects one line on setting up the network connection. A group of identical ports is merely identified by the same subnet ID.

In the case of dedicated lines to an NEA network partner, multilinks are more efficient than groups due to the higher data throughput.

Grouped lines are better for switched circuits, since free ports can be dynamically selected from within the group.

4.3 Configuring a default route

The configuration of partner systems can be simplified to a large extent for some network configurations. This is done by configuring a default route, i.e. by defining a route via which a group of NEA computers can be reached (attribute value **/** or **/r* as the processor/region number for *nea-addr-pattern* in the GNSAP object). This default route can also be used to reach partner systems that are not explicitly configured in the FSS. The direct partner system that leads to the default route must be an Intermediate System (IS). Seen from a local viewpoint, this system is known as the default router.

Sample configuration

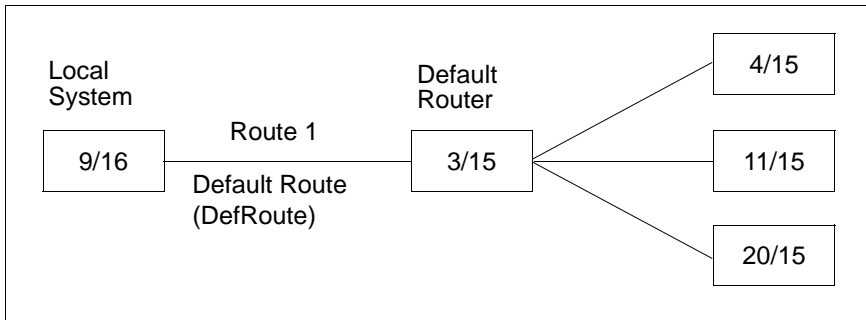

Figure 15: Default route

The following configuration options using the menu system or command interface are all related to the sample configuration shown above.

Configuration using the menu system

To set the default route, proceed as follows:

- ▶ From the CMX main menu, select the item *NSAPs - Remote Hosts...*
- ▶ Press **ENTER** in the *Remote Hosts* menu without marking an item.
- ▶ Select the menu item *Create* from the *Operations on Remote Systems* menu.
- ▶ You can then enter your network configuration in the *Remote NSAP Information* menu.

Example

The route *DefRoute* must be configured beforehand under *SNPAROUTES - Routes to Remote Subnetwork Interfaces...* in the CMX main menu. Any name may be selected as the *DefRoute* name.

```

                Name: DefaultNEARouter
                Network: NEA
Processor-/Region number: */*
                Subnet address: static route(s)
                List of routes: DefRoute

```

Configuration using the command interface

The partner systems that can be reached via the same subnet route are represented collectively by means of a GNSAP object in which a generalized NEA address (*nea-addr-pattern*) has been defined.

Example of an FSS configuration file

```

LOCNSAP ( name=P9R16 nea-addr=9/16 )
SNPAROUTES ( name=DefRoute subnet=X21-1 type=X21
              dial-nr=65432 )
GNSAP ( name=DefaultNEARouter nea-addr-pattern=*/* net=NEA
        access=DIRECT snpa-list=DefRoute )

```

4.4 KOGS, FSS and TNS parameters

The following sections contain lists that show which of the specified parameters and value ranges for KOGS macros and for the FSS and TNS data bases that are presented in the chapter “Configuration with KOGS macros” on page 223 can be used for the WAN-NEA profile. A description of the FSS parameters can be found in the chapter “FSS configuration” on page 269. The TNS is described in the “CMX, Operation and Administration” User Guide [1].

4.4.1 KOGS parameters

The meanings of the individual macros and operands listed below can be found in the chapter “Configuration with KOGS macros” on page 223.

Macro	Operands	Operand values
XEND		
XLTNG	[CTIMER]	<u>0</u> ...450
	[DUETYP]	<u>MODEM</u> , DIREKT, V35/V36-ADAPTER
	[FRMRANZ]	0... <u>2</u> ...255
	LPUFADR	1...4
	[MAXIFL]	1... <u>4096</u>
	[MLNK]	1...9
	[MODE]	<u>SIE</u>
	[MODTAKT]	<u>NEIN</u> (NO) (for DUETYP=DIREKT) <u>JA</u> (YES) (otherwise)
	[NRZI]	<u>JA</u> (YES) , NEIN (NO)
	[OPTIONS]	([1],[2],[4],[7],[8],[10],[12],[13]) (<u>1,2,4,8</u>) for PLIDENT= <i>hexvalue</i> (<u>2,4,8</u>) (otherwise)
	[PLIDENT]	<u>NEIN</u> (NO), <i>hexvalue</i>
	[POLLPAU]	100... <u>500</u> ...3600 (for HDLC-UNB) <u>0</u> (otherwise)
	[PROFIL]	NEA

Table 4: KOGS parameters for the WAN-NEA profile

Macro	Operands	Operand values
	[PRTIMER]	3000...60000 for X.21 Default depends on UEGSW
	[PRTIM2]	100... <u>500</u> ...3000
	[PRTIM3]	<u>0</u> ...60000 0... <u>65000</u> ...6000000 for UEPROZ=HDLC/UNB and UEUNB=SEC/...
	[RCB]	<u>0</u> ...65535
	[RUF]	AUTO AUTO/ANK, AUTO/ABG DIREKT, DIREKT/ABG MANUELL, MANUELL/ABG
	[RUFNUM]	<i>call number</i> up to 24 characters
	[RUFPAUS]	<u>6</u> ...120
	[RUFWDH]	0... <u>3</u> ...7
	[TPAUSE]	<u>NEIN</u> (NO), JA (YES)
	[UEGSW]	1200... <u>9600</u> ...19200 for V24DEF (increases for DUETYP=V35/36-ADAPTER to 64000) 1200... <u>9600</u> ...19200, 48000, 64000, 128000, 256000, 512000, 1024000, 204800 for X21DEF
	[UEKONF]	<u>PZP</u> , MP
	[UEPROZ]	<u>HDLC/BAC</u> , HDLC/UNB
	[UEUNB]	<u>PRI/DX</u> , PRI/HX, SEC/HX, SEC/DX
	UEWEG	FE-STAND/2DR, FE-STAND/4DR FE-WAHL/2DR, FE-WAHL/4DR DATEX-L, DATEX-L/X21, DATEX-L/V24
	[VUEZEIT]	0... <u>24</u> ...127
	[V24DEF]	STD
	[WDHZAHL]	0... <u>3</u> ...255
	[X21DEF]	<u>DBP</u>
XPRO	[LINKADR]	(1... <u>3</u> ...254, <u>1</u> ...254) (own, partner) 1...222; only relevant for dedicated line

Table 4: KOGS parameters for the WAN-NEA profile

Macro	Operands	Operand values
	[PRIDENT]	<u>NEIN</u> (NO), <i>hexvalue</i>
	[RUFNUM]	<i>call number</i> for identification exchange up to 24 characters
XSNID	ADRTYP	X21_ADR or X21-ADR for X.21 dial-up line HDLCPP for HDLC point-to-point connections PT_ADR or PT-ADR for phone networks
	SUBNID	X21-i, i=1...32 for X.21 dial-up line PP-i, i=1...32 for dedicated lines PT-i, i=1...32 for phone networks
XSYSP		

Table 4: KOGS parameters for the WAN-NEA profile

4.4.2 FSS parameters

For more information on the individual object classes and attributes, see chapter “FSS configuration” on page 269.

Object class FACIL: define facilities

Attribute	Format	Meaning
name	1-15 characters comprising letters, digits, and the special characters _ and #. A distinction is made between uppercase and lowercase. The first character must not be a digit or underscore ('_').	Name of the FACIL object
facil	See <i>name</i>	Name of a further FACIL object that is referenced
npid	NEA	Network protocol ID

Table 5: Attributes of the FACIL object class

Object class GNSAP: Generalized NSAP

Attribute	Format	Meaning
name	1-32 printable and visible characters	Name of the GNSAP object
nea-addr-pattern	<i>*/r</i> where <i>r</i> (0 ... 255) <i>*/*</i>	All NEA computers of the specified region. All NEA computers
snpa-list	<i>snpa+snpa+...+snpa</i> with max. 20 list items. <i>snpa: name name/weight</i> <i>name: see name</i> under SNPAROUTES <i>weight: a digit</i> from 1-20	List of routes that can be used to reach NEA systems represented by this GNSAP. The priority can be specified with a value for <i>weight</i> (20 is the highest priority).

Table 6: Attributes of the GNSAP object class

Object class LOCNSAP: Local host

Attribute	Format	Meaning
name	1-32 printable and visible characters	Name of the LOCNSAP object
nea-addr	<i>p/r</i> where <i>p</i> and <i>r</i> are decimal numbers (0 ... 255)	NEA address: processor/region number. The attribute is supplied automatically when installing NEA. If changes are made, an nea restart must be performed.

Table 7: Attributes of the LOCNSAP object class

Object class NSAP: Remote network service access points

Attribute	Format	Meaning
name	1-32 printable and visible characters	Name of the NSAP object
nea-addr	<i>p/r</i> where <i>p</i> and <i>r</i> (0 ... 255)	NEA address: processor/region number
net*	NEA	Network used by the local system to reach the NSAP
access*	DIRECT	Access to the SNPA address via which the NSAP can be reached
snpa-list	<i>snpa+snpa+...+snpa</i> with max. 20 list items. <i>snpa</i> : <i>name</i> <i>name/weight</i> <i>name</i> : see <i>name</i> under SNPAROUTES <i>weight</i> : digit from 1-20	List of alternative SNPAROUTES objects that can be used to reach this NSAP. The priority can be specified with a value for <i>weight</i> (20 is the highest priority)

Table 8: Attributes of the NSAP object class

* The “net” and “access” attributes need not be specified in the configuration file or in the command (fssadm create NSAP...), since they are implicitly derived from other attributes.

Additional filter criteria that are only permitted for fssadm get:

Attribute	Format	Meaning
type	X21 PP X21DIRECT PT	Subnet address type
subnet	X21- <i>n</i> PT- <i>n</i> PP- <i>n</i> <i>n</i> = 1, .., 32	Subnet ID

Table 9: Filter attributes of the NSAP object class

Object class SNPAROUTES: Routes**Association between subnet address type and subnet ID**

Depending on the subnet address type, you can assign the subnet ID as follows:

Subnet addr. type	Subnet ID
X21 X21DIRECT	X21-x
PP (point-to-point)	PP-x
PT (Public Telephone)	PT-x

Table 10: Assignment of subnet ID to subnet address type

Attribute	Format	Meaning
name	1-15 characters comprising letters, digits, and the special characters _ and #. A distinction is made between uppercase and lowercase. The first character must not be a digit or an underscore '_'	Name of the SNPAROUTES object
dial-nr*	<i>dial-no</i> DIRECT/ <i>dial-no</i> <i>dial-no</i> : 1-24 decimal digits or any 1-24 any visible characters enclosed in single quotes ('')	Remote X.21 call number. In the case of "Direct Mode": local X.21 call number.
phone-nr*	<i>phone-no</i> <i>phone-no</i> : 1-24 decimal digits or any 1-24 any visible characters enclosed in single quotes ('')	Telephone number
line-nr*	[<i>cc-no</i>]/ <i>line-no</i> <i>cc-no</i> : 1 ... 256 <i>line-no</i> : 1 2 3 4	Optional attribute: line number for dedicated line (KOGS parameter LPUFADR). If line-no is omitted, type=PP must be specified

Table 11: Attributes of the SNPAROUTES object class

Attribute	Format	Meaning
type	X21 PP X21DIRECT PT	Subnet address type
facil	See <i>name</i>	Name of a FACIL object
subnet	X21- <i>n</i> PT- <i>n</i> PP- <i>n</i> <i>n</i> = 1, ..., 32	Subnet ID

Table 11: Attributes of the SNPAROUTES object class

* The “dial-nr”, “phone-nr” and “line-nr” attributes are mutually exclusive.

4.4.3 TNS parameters

Detailed information on the TNS and on the TNS entries for the program interface can be found in the “CMX, Operation and Administration“ User Guide [1].

TNS entries for the local application:

Global name	Type	Addr. format	T-selector
<i>Global name</i>	TSE L	WANNEA	{T A E X} string <i>string</i> with max. 8 characters

TNS entries for the remote application:

Global name	Type	Addr. format	Addr. component
<i>Global name</i>	TA	WANNEA	{T A E X} string <i>string</i> with max. 8 characters processor/region (0...255/0...255) [WAN cc-no:line identifier]

Depending on which applications expand on the CMX, session components (SSEL) and presentation components (PSEL) may be specified. See the “CMX, Operation and Administration“ User Guide [1] for details.

4.5 Configuration using the menu system

This section describes configuration using the menu system *CMXCUI*.

4.5.1 Configuring the local subnetwork interface

Menu	Choice
CMX Main Menu	CFs - CCP Configuration Files
Select the network access software	WAN
Configuration files for the WAN network access	a) Change CF: b) Create new CF: <input type="text" value="ENTER"/>
Operations on CFs	Create... or Edit
Create a New File	Name of configuration file: <i>name</i> Select CC type for the KOGS

When you the entries, a submenu to create the configuration file *name* for the selected CC type appears:

Edit configuration file [<i>name</i>] for <i>cc-type</i>	Select one of the displayed lines
Configuration for WAN Interface <i>no</i>	Local
Configure local network interface	Subnetwork: (X21 dial-up line, dedicated line, multipoint, telephony) Subnet ID: X21- <i>n</i> , PT- <i>n</i> , PP- <i>n</i> Own X.21 call number Own telephone number Own line number Default transport protocol: NEA
Parameter for Interface <i>no</i> to <i>network</i>	Modify line parameters or confirm default values, e.g. setup of dial-up connection, transmission speed, link address, NRZI, HDLC protocol variant, various timers, multilink XID exchange, own XID value
Parameter for Interface <i>no</i> to <i>network</i> (only for XID exchange: HEX)	Remote

XID of Remote Systems via Interface *no* Remote Call Number:
 XID Value (hex):

Configuration for WAN Interface *no* Compile

Configuration for WAN Interface *no* Exit

In order to ensure that your configuration entries take effect, you must assign the WAN network access and the generated configuration file to a Communications Controller and load the Communications Controller. See the section „Assigning and loading the configuration file“ on page 66.

4.5.2 Defining your own network address

Menu	Choice
CMX Main Menu	Local Host
Local Host	NEA Processor: Region:

4.5.3 Defining routes

Menu	Choice
CMX Main Menu	SNPAROUTES - Routes to Remote Subnetwork Interfaces
Routes to Remote Subnetwork Interfaces	a) Change route: MARK, ENTER b) Create new route: ENTER
Operations on Routes to Remote Subnetwork Interfaces	Create... or Change...
Attributes of a Route	Name: <i>name</i> Type of subnet address: <i>X21, X21DIRECT, PT or PP</i> Subnet ID: <i>X21-n, PT-n or PP-n</i> (must match the subnet ID in the CF) Specify remote subnetwork address: Subnet address: e.g. X.21 call number, phone number, line number. Facilities: <i>no</i>

Menu**Choice**

If you have specified *Facilities: yes*, a further menu to create facilities will appear when you save your entry:

Facilities to Route [*name*]

Net Protocol ID: NEA
(required if the parameter PROFIL=NEA was not specified in the KOGS macro XLTNG)

The net protocol ID need not be specified for:

- phone connections
- X.21 ports without the facility to “display the call number of the calling partner”

4.5.4 Entering partner systems

Menu**Choice**

CMX Main Menu

NSAPs - Remote Hosts...

Remote Hosts ...

a) Change remote network address:

,

b) Create new network address:

Operations on Remote Systems

Create... or Change...

Remote NSAP Information

Name: *name*

Network: NEA

Processor/Region number:

Subnet Address:

Static routes:

List of routes: you must specify the name of the route(s) to be used.

4.5.5 Entering transport system applications

This section briefly describes the individual worksteps in the CMX menu system in the form of an overview. A detailed description can be found in the "CMX, Operation and Administration" User Guide [1].

Menu	Choice
CMX Main Menu	TSAs - Transport System Applications...
GLOBAL NAME of TS Application	a) Change global name: <div style="border: 1px solid black; padding: 2px; display: inline-block;">CHOICES</div> , <div style="border: 1px solid black; padding: 2px; display: inline-block;">ENTER</div> b) Create new global name: specify name part [1] - [5] (all name parts are optional)
Operations on TS Applications	Assign or Change LOCAL NAME
LOCAL NAME of TS Application	CCP profile: WAN-NEA T-selector:
Operations on TS Applications	Assign or Change TRANSPORT ADDRESS
CCP profile to be used	WAN-NEA
TRANSDATA Transport Address	Station name of TS application: Name of the remote system TRANSDATA network address: p/r CC list: optional

4.6 Examples

This section contains examples to illustrate the configuration of the WAN-NEA profile with different types of connections, i.e. dedicated and dial-up lines. It also includes operating instructions for the same configurations by means of the menu system (*CMXCUI*).

4.6.1 WAN-NEA: dedicated lines, balanced

TNS entries

```
neatest\
    TA          WANNEA T'NEATEST' 1/2
```

FSS entries

```
LOCNSAP ( name = hugo nea-addr=08/15 )
SNPAROUTES ( name=rstand1 subnet=PP-18)
NSAP ( name=partner1/2 nea-addr=1/2 snpa-list=rstand1 )
```

KOGS source file

```
XSYSP
XSNID   SUBNID = PP-18,
        ADRTYP = HDLCPP

XLTNG   LPUFADR = 1,
        PROFIL = NEA,
        DUETYP = MODEM,
        NRZI = JA,
        PRIM2 = 500,
        WDHZAE = 3,
        UEGSW = 9600,
        TPAUSE = NEIN,
        X21DEF = DBP,
        UEPROZ = HDLC/BAC,
        UEKONF = PZP,
        UEWEG = FE-STAND/4DR

XPRO    LINKADR = (3,1)
XEND
```

Entries in the menu (without TNS):

Menu item: *Local - Local Host ...*

- ▶ Enter:
 - NEA Processor: 08, Region: 15

Menu item: *SNPAROUTES - Routes to Remote Subnetwork Interfaces...*

- ▶ Enter the following in the *Attributes of a Route* menu:
 - Name: rstand1
(Name of the route. This route can be referenced by name in the NSAP object.)
 - Type of Subnet address: PP (dedicated line)
 - Subnet ID: PP-18
(PP-* identifies the type of subnetwork. The number (18) provides a unique identification for the subnetwork in the system, i.e. for the dedicated line in this case. This subnet ID must also be specified in the configuration of the corresponding line on the Controller.)
 - The line number on the Controller.

Menu item: *NSAPs - Remote Hosts ...*

- ▶ Enter the following in the *Remote NSAP Information* menu:
 - Name: partner1/2
 - Network: NEA
 - NSAP address: 1/2
 - Subnet address: static routes
 - List of routes: rstand1

Menu item: *CFs - CCP Configuration Files...*

- ▶ Select WAN from the *Select Network Access* menu.
- ▶ Enter the following in the *Create a New File* menu:
 - Name of configuration file: name
 - Type of CC to create for: cc-type
- ▶ Select a line from the *Edit configuration file...* menu.
- ▶ In the *Configuration for WAN Interface <no>* menu, select the menu item *Local*.

- ▶ In the *Configure local network* menu, enter:
 - Subnetwork: `Dedicated_Line`
 - Subnet ID: same entry as in the FSS
 - Default transport protocol: `NEA`
- ▶ Accept the default values in the *Parameter for Interface <no>* menu.

4.6.2 WAN-NEA: dial-up line, remote dialing

TNS entries

```
nea2test\  
      TA      WANNEA T'NEA2TEST' 60/18
```

FSS entries

In addition to a route entry for the phone number of the remote partner, a route entry is also required for your own phone number in order to select the TSP and protocols for an incoming call. You do this with a FACIL entry `npid=NEA`. You do not have to make a route entry for your own phone number if `PROFIL=NEA` is entered in the `XLTNG` macro in the `KOGS` source file.

```
FACIL ( name = loktel npid=NEA )  
LOCNSAP ( name=PGTR0023 nea-addr=23/18 )  
SNPAROUTES ( name=LOCAL subnet=PT-1 phone-nr=4841 facil=loktele )  
SNPAROUTES ( name=R1 subnet=PT-1 phone-nr=4846 )  
NSAP ( name=N1 nea-addr=60/18 snpa-list=R1 )
```

KOGS source file

```

XSYSP
XSNID   SUBNID=PT-1,
        ADRTYP = PT_ADR
XLTNG   LPUFADR = 1,
        RUFNUM = 4841,           # Phone number of the local
                                # port
        DUETYP = MODEM,
        NRZI = JA,
        PROFIL = NEA,
        VUEZEIT = 24,
        UEGSW = 2400,
        UEKONF = PZP,
        UEPROZ = HDLC/BAC,
        RUF = AUTO,
        UEWEG = FE-WAHL/4DR, # Dial-up phone connection
        OPTIONS = (2,8),      # HDLC options without
                                # identification exchange
        V24DEF = STD
XEND

```

Entries in the menu (without TNS):

Differences with respect to the dedicated line:

Menu item: *SNPAROUTES - Routes to Remote Subnetwork Interfaces...*

- For the own port:
 - ▶ Enter the following in the *Attributes of a Route* menu:
 - Name: LOCAL
 - Type of remote subnet address: PT
 - Subnet ID: PT-1
 - Telephone number: 4841
 - Facilities: yes
 - ▶ In the *Facilities to Route* menu, enter:
 - Net Protocol ID: NEA

- For the remote partner:
 - ▶ Enter the following in the *Attributes of a Route* menu:
 - Name: R1
 - Type of remote subnet address: PT
 - Subnet ID: PT-1
 - Telephone number: 4846

Menu item: *CFs - CCP Configuration Files...*

For every line:

- ▶ Select WAN from the *Select Network Access* menu.
- ▶ Enter the following in the *Create a New File* menu:
 - Name of configuration file: name
 - Type of CC to create for: cc-type
- ▶ Select a line from the *Edit configuration file...* menu.
- ▶ In the *Configuration for WAN Interface <no>* menu, select *Local*.
- ▶ In the *Configure local network* menu, enter:
 - Subnetwork: Telephone_Line
 - Subnet ID: same entry as in the FSS
 - Own telephone number: 4841
 - Default transport protocol: NEA
- ▶ In the *Parameter for Interface <no>* menu:
 - Accept the default values
 - Enter XID exchange: no

In the case of a configuration “with XID exchange”, you must specify the XID string (PLIDENT) for the local port. In addition, the respective call number and the XID string (PRIDENT in the XPRO macro) must be defined for all remote direct partners.

4.6.3 WAN-NEA: dedicated line, unbalanced, point-to-point

TNS entries

```
neatest\  
    TA      WANNEA T'NEATEST' 1/2
```

FSS entries

```
SNPAROUTES ( name=rstand1 subnet=PP-18)  
NSAP ( name=partner1/2 nea-addr=1/2 snpa-list=rstand1 )
```

KOGS source file

```
XSYS  
XSNID      SUBNID = PP-18,  
           ADRTYP = HDLCPP  
XLTNG      LPUFADR = 1,  
           PROFIL = NEA,  
           DUETYP = MODEM,  
           NRZI = JA,  
           PRTIM2 = 500,  
           WDHZAE = 3,  
           UEGSW = 9600,  
           TPAUSE = NEIN,  
           X21DEF = DBP,  
           UEPROZ = HDLC/UNB,  
           UEUNB = PRI/DX,  
           UEKONF = PZP,  
           UEWEG = FE-STAND/4DR  
XPRO  
XEND      LINKADR = 1
```

Entries in the CMX menu system (without TNS):

Differences with respect to the dedicated line, balanced:

Menu item: *CFs - CCP Configuration Files...*

- ▶ Enter the following in the *Parameter for Interface <no>* menu:
 - HDLC Transmission procedure: HDLC/UNB
 - Function of HDLC protocol: PRI/DX (for primary controller) or SEC/DX (for secondary controller)

4.6.4 WAN-NEA: multipoint secondary (for SK12)

TNS entries

```
neatest\
    TA          WANNEA T'NEATEST' 1/2
```

FSS entries

```
SNPAROUTES ( name=rstand1 subnet=PP-18)
NSAP ( name=partner1/2 nea-addr=1/2 snpa-list=rstand1 )
```

KOGS source file

```
XSYSP
XSNID      SUBNID = PP-18,
           ADRTYP = HDLCPP
XLTNG     LPUFADR = 1,
           PROFIL = NEA,
           DUETYP = MODEM,
           NRZI = JA,
           PRTIM2 = 500,
           WDHZAEL = 3,
           UEGSW = 9600,
           TPAUSE = NEIN,
           X21DEF = DBP,
           UEPROZ = HDLC/UNB,
           UEUNB = SEC/DX,
           UEKONF = MP,
           UEWEG = FE-STAND/2DR,
           CTIMER = 30
XPRO      LINKADR = 33
XEND
```

Entries in the CMX menu system (without TNS):

Differences with respect to the dedicated line, balanced:

- ▶ Enter the following in the *Configure local network* menu:
 - Subnetwork: `Multipoint_Line`
 - Subnet ID: same entry as in the FSS
 - Default transport protocol: NEA
- ▶ In the *Parameter for Interface <no>* menu:
 - Type of line: 2DR
 - Function of HDLC protocol: SEC/DX
 - HDLC link address: nn

In addition, if an SK12 concentrator is used on the secondary side with X.21, the cascade level n must be specified in the parameter `CTIMER = n * 30`.

5 The WAN-NX25 profile

5.1 Profile description

The WAN-NX25 profile enables you to integrate your system in a TRANSDATA network via a packet switching network (e.g. Datex-P, Transpac, PSS, etc.).

Processor/Region numbers for NEA systems may be specified by means of placeholders, i.e. “wildcards” (*), instead of actual addresses. This method can be used to create a default route for a specific set of NEA partners (see the section “Configuring a default route” on page 102).

The NEA routing function enables your system to operate as an Intermediate System (IS) that forwards NEA data packets to other NEA computers.

The figure below illustrates how your system is connected to a packet switching network using the WAN-NX25 profile:

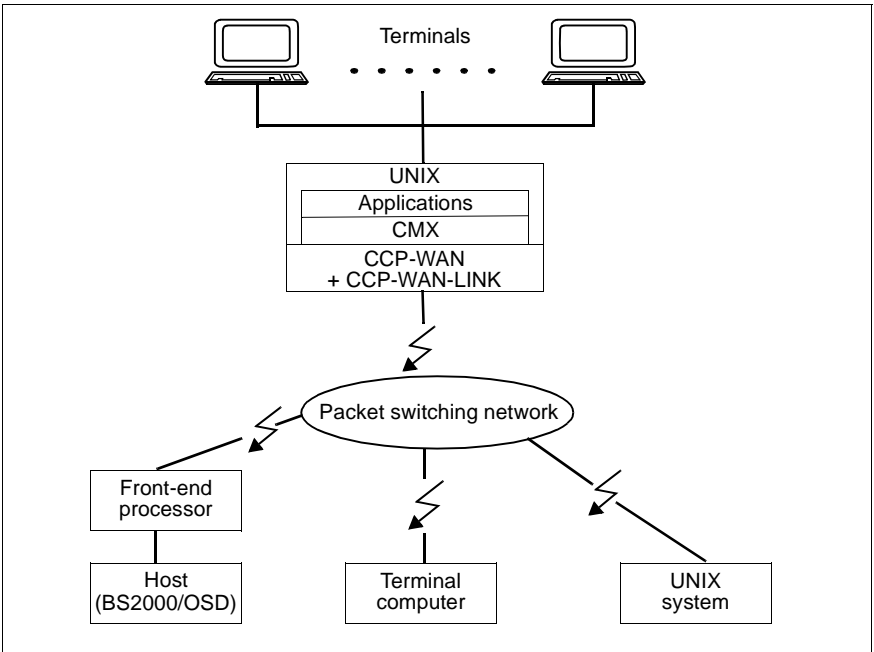

Figure 16: Connection of a UNIX system using the WAN-NX25 profile

Transport system protocols

The following protocols are assigned to the layers of the transport system in the WAN-NX25 profile:

Layer	Function	Protocols
4	Transport	NEATE
3	Network	NEAN X.25-3
2	Data Link	HDLC/LAPB
1	Physical	X.21/X.21bis

Table 12: Transport system protocols for the WAN-NX25 profile

5.2 Configuring a default route

The configuration of partner systems can be simplified to a large extent for some network configurations. This is done by configuring a default route, i.e. by defining a route via which a group of NEA computers can be reached (attribute value */* or */r as the processor/region number for nea-addr-pattern in the GNSAP object). This default route can also be used to reach partner systems that are not explicitly configured in the FSS. The direct partner system that leads to the default route must be an Intermediate System (IS). Seen from a local viewpoint, this system is known as the default router.

Sample configuration

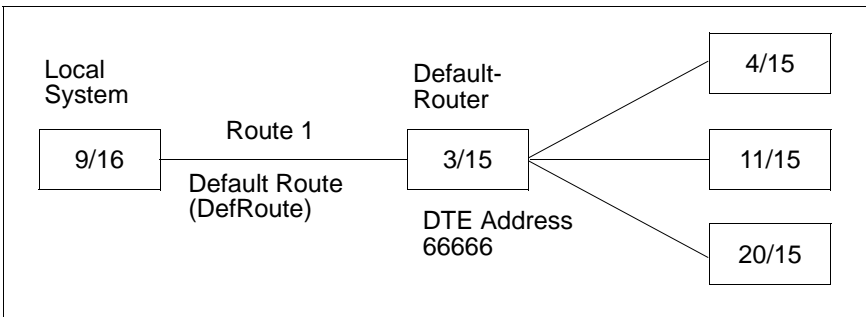

Figure 17: Default route

The following configuration options using the menu system or command interface are all related to the sample configuration shown above.

Configuration using the menu system

To set the default route, proceed as follows:

- ▶ From the CMX main menu, select the item *NSAPs - Remote Hosts ...* .
- ▶ Press **[ENTER]** in the *Remote Hosts* screen without marking a point.
- ▶ Select the menu item *Create* from the *Operations on Remote Systems* menu.
- ▶ You can then enter your network configuration in the *Remote NSAP Information* screen.

Example

The route *DefRoute* must be configured under *Route - Routes to Remote Subnetwork Interfaces...* in the CMX main menu. Any name may be selected as the *DefRoute* name.

```

Name: DefaultNEARouter
Network: NEA
Processor-/Region number: */*
Subnet address: static route(s)
List of routes: DefRoute

```

Configuration using the command interface

The partner systems that can be reached via the same route are represented collectively by means of a GNSAP object in which a generalized NEA address (*nea-addr-pattern*) has been defined.

Example of an FSS configuration file

```

LOCNSAP ( name=P9R16 nea-addr=9/16 )
SNPAROUTES ( name=DefRoute subnet=X25-1 dte-addr=66666 )
GNSAP ( name=DefaultNEARouter nea-addr-pattern=*/* net=NEA
        access=DIRECT snpa-list=DefRoute )
NSAP (name=P9R16, nea-addr=9/16, ...snpa-list=DefRoute)

```

5.3 NEA routing

NEA routing is the functionality that allows incoming NEA data packets that are not intended for the own system to be forwarded via routes configured for this system. Any system that supports this functionality is called an Intermediate System (IS).

In an NEA network, a system can be operated as an end system (ES) and as an intermediate system at the same time. Consequently, no dedicated system is now required for occasional routing.

The NEA routing function can be turned on and off by means of the menu and command interface. The default setting is OFF, i.e. NEA routing is not activated. In other words, your system functions as an end system (ES) by default.

5.4 KOGS, FSS and TNS parameters

The following sections contain lists that show which of the specified parameters and value ranges for SKOGS macros and for the FSS and TNS data bases that are presented in the chapter “Configuration with KOGS macros” on page 223 can be used for the WAN-NX25 profile. A description of the FSS parameters can be found in the chapter “FSS configuration” on page 269. The TNS is described in the “CMX, Operation and Administration” User Guide [1].

5.4.1 KOGS parameters

The meanings of the individual macros and operands listed below can be found in the chapter “Configuration with KOGS macros” on page 223.

Macro	Operands	Operand values
XEND		
XFACI	[AKFACI]	<u>NOREVCH</u> REVCH FASTSEL <i>list</i>
	[DTEADCA]	JA (YES) TOANPI <i>list</i>
	FACIL	<i>name</i> max. 7 characters
	[PAKLE]	16...2048 (power of 2)
	[PAKLS]	16...2048 (power of 2)
	[PAKNUM]	<u>MOD8</u> MOD128
	[R20]	1... <u>10</u> ...128
	[R22]	1... <u>10</u> ...128
	[R23]	1... <u>2</u> ...128
	[T20]	1... <u>10</u> ...2048

Table 13: KOGS parameters for the WAN-NX25 profile

Macro	Operands	Operand values
	[T21]	1... <u>200</u> ...2048
	[T22]	1... <u>10</u> ...2048
	[T23]	1... <u>10</u> ...2048
	[T24]	<u>0</u> ...2048
	[T25]	0... <u>180</u> ...2048
	[WINDE]	PAKNUM = MOD8: 1... <u>2</u> ...7 PAKNUM = MOD128: 1... <u>2</u> ...127
	[WINDS]	PAKNUM = MOD8: 1... <u>2</u> ...7 PAKNUM = MOD128: 1... <u>2</u> ...127
XLTNG	[DTEADR]	<i>decimal number</i> max. 17 digits
	[DUETYP]	<u>MODEM</u>
	[FACIL]	<i>name</i> max. 7 characters
	[FRMRANZ]	0... <u>2</u> ...255
	LPUFADR	1...4
	[MAXIFL]	1... <u>4096</u>
	[PKANALN]	0...4095-0...4095
	[PROFIL]	NEA
	[PRTIMER]	<u>3000</u> ...60000
	[PRTIM2]	100... <u>3000</u>
	[PRTIM3]	<u>0</u> ...65000
	[RCB]	<u>0</u> ...65535
	[SKANABG]	1...4095-1...4095
	[SKANALN]	1...4095-1...4095
	[SKANANK]	1...4095-1...4095
	[TPAUSE]	<u>NEIN</u> (NO), JA (YES)
	[UEGSW]	2400...64000

Table 13: KOGS parameters for the WAN-NX25 profile

Macro	Operands	Operand values
	UEWEG	X25/TYP5, X25/TYP6, X25/TYP8, X25/TYP9, X25/TYP56, X25/TYP58
	[V24DEF]	STD
	[WDHZAHL]	0...3...255
	[X21DEF]	<u>DBP</u>
XSNID	ADRTYP	X25_ADR or X25-ADR
	SUBNID	X25-i, i=1...32
XSYSP		

Table 13: KOGS parameters for the WAN-NX25 profile

5.4.2 FSS parameters

For more information on the individual object classes and attributes, see chapter “FSS configuration” on page 269.

Object class FACIL: Define facilities

Attribute	Format	Meaning
name	1-15 characters comprising letters, digits, and the special characters _ and #. A distinction is made between uppercase and lowercase. The first character must not be a digit or an underscore ‘_’.	Name of the FACIL object
facil	See <i>name</i>	Name of another FACIL object that is referenced
npid	NEA	Network protocol ID
x25-octet-string	1...109 octets in hex format	DTE facilities in accordance with CCITT X.25 Annex G (IS8208)

Table 14: Attributes of the FACIL object class

Attribute	Format	Meaning
x25-packet-size	Send direction[/receive direction] with the individual values for S/R: 16 32 64 128 256 512 1024 2048. If R is not specified, R=S.	Packet size
x25-window-size	Send direction[/receive direction] with the individual values for S/R: 1-7, if XFACI PAKNUM=MOD8 1-127, if XFACI PAKNUM=MOD128	Window size
x25-throughput	Send direction[/receive direction] with the individual values for S/R in Kbit/s: 2,4 4,8 9,6 19,2 48 64	Throughput class
x25-cug	0-9999. Leading zeros are evaluated: 1-2-digit input means 'basic format'; 3-4-digit input means 'extended format'.	Selection of closed user group
x25-cug-oa	0-9999. See <i>x25-cug</i>	Selection of a closed user group with unrestricted outgoing call
x25-bcug	0-9999. Leading zeros are not evaluated. The "extended format" must always be used.	Selection of a bilat- erally closed user group
x25-revch	B[OTH_REQ_AND_ACC] R[EQUEST_ONLY] A[CCEPT_ONLY] N[EITHER_REQ_NOR_ACC]	Request reverse charges or accept request for reversed charges
x25-transit-delay	0-65534 milliseconds	Desired transmission time
x25-fast-select	N[O-RESTRICTION] R[ESTRICTION]	Fast select (short dialog using the Call User Data field)

Table 14: Attributes of the FACIL object class

Attribute	Format	Meaning
x25-rpoa	DNIC[+DNIC...] with a maximum of 12 elements	Selection of a route via one (or more) transit networks identified by their DNIC (Data Network Identification Code)
x25-nui	Max. 16 printable characters (ASCII, EBCDIC) or max. 16 hexadecimal digit pairs: Format: <i>formind:nui-value</i> <i>formind</i> = A E X	Network User Identification

Table 14: Attributes of the FACIL object class

Object class GNSAP: Generalized NSAP

Attribute	Format	Meaning
name	1-32 printable and visible characters	Name of the GNSAP object
nea-addr-pattern	<i>*/r</i> where <i>r</i> (0 ... 255) <i>*/*</i>	All NEA computers of the specified region. All NEA computers
snpa-list	<i>snpa+snpa+...+snpa</i> with max. 20 list elements. <i>snpa</i> : <i>name</i> <i>name/weight</i> <i>name</i> : see <i>name</i> under SNPAROUTES <i>weight</i> : digit from 1-20	List of routes that can be used to reach NEA systems represented by this GNSAP. The priority can be specified with a value for <i>weight</i> (20 is the highest priority).

Table 15: Attributes of the GNSAP object class

Object class LOCNSAP: Local host

The local network address has to be configured before installing the NEA address. It does not take affect immediately but rather after NEA has been deinstalled and subsequently reinstalled.

Attribute	Format	Meaning
name	1-32 printable and visible characters	Name of the LOCNSAP object
nea-addr	<i>p/r</i> where <i>p</i> and <i>r</i> are decimal numbers (0 ... 255)	NEA address: processor/region number.

Table 16: Attributes of the LOCNSAP object class

Object class NSAP: Remote network service access point

Attribute	Format	Meaning
name	1-32 printable and visible characters	Name of the NSAP object
nea-addr	<i>p/r</i> where <i>p</i> and <i>r</i> (0 ... 255)	NEA address: processor/region number
net*	NEA	Network used by the local system to reach the NSAP
access*	DIRECT	Access to the SNPA address via which the NSAP can be reached
snpa-list	<i>snpa+snpa+...+snpa</i> with max. 20 list elements. <i>snpa</i> : <i>name</i> <i>name/weight</i> <i>name</i> : see <i>name</i> under SNPAROUTES <i>weight</i> : digit from 1-20.	List of alternative SNPAROUTES objects that can be used to reach this NSAP. The priority can be specified with a value for <i>weight</i> (20 is the highest priority).

Table 17: Attributes of the NSAP object class

* The “net” and “access” attributes need not be specified in the configuration file or in the *create* command (*fssadm create NSAP...*), since they are implicitly derived from other attributes.

Additional filter criteria that are only permitted for *fssadm get*:

Attribute	Format	Meaning
type	X25 PVC	Subnet address type
subnet	X25- <i>n</i> <i>n</i> = 1, ..., 32	Subnet ID

Table 18: Filter attributes of the NSAP object class

Object class SNPAROUTES: Routes

Association between subnet address type and subnet ID

Depending on the subnet address type, you can assign the subnet ID as follows:

Subnet addr. type	Subnet ID
X25 PVC	X25-x

Table 19: Assignment of subnet ID to subnet address type

Attribute	Format	Meaning
name	1-15 characters comprising letters, digits, and the special characters _ and #. A distinction is made between uppercase and lowercase. The first character must not be a digit or an underscore ‘_’.	Name of the SNPAROUTES object
dte-addr*	1-17 decimal digits	Remote X.25 DTE address
pvc-nr*	<i>pvc</i> [/ <i>dte</i>] <i>pvc</i> : decimal number (0 ... 4095) <i>dte</i> : 1-17 decimal digits	X.25 PVC number and associated local DTE address
type	X25 PVC	Subnet address type

Table 20: Attributes of the SNPAROUTES object class

Attribute	Format	Meaning
facil	See <i>name</i>	Name of a FACIL object
subnet	X25- <i>n</i> <i>n</i> = 1, .., 32	Subnet ID

Table 20: Attributes of the SNPAROUTES object class

* The “dte-addr” and “pvc-nr” attributes are mutually exclusive. The implicit types for the “pvc-nr” and “dte-addr” entries are “type=PVC” and “type=X25”, respectively.

5.4.3 TNS parameters

Detailed information on the TNS and on the TNS entries for the program interface can be found in the “CMX, Operation and Administration“ User Guide [1].

TNS entries for the local application:

Global name	Type	Addr. format	T-selector
<i>Global name</i>	TSEL	WANNEA	{T A E X} string <i>string</i> with max. 8 characters

TNS entries for the remote application:

Global name	Type	Addr. format	Addr. component
<i>Global name</i>	TA	WANNEA	{T A E X} string <i>string</i> with max. 8 characters processor/region (0...255/0...255) [WAN cc-no:line identifier]

Depending on which applications expand on the CMX, session components (SSEL) and presentation components (PSEL) may be specified. See the “CMX, Operation and Administration“ User Guide [1] for details.

5.5 Configuration using the menu system

This section describes configuration using the menu system *CMXCUI*.

5.5.1 Configuring the local subnetwork interface

Menu	Choice
CMX Main Menu	CFs - CCP Configuration Files...
Select Network Access	WAN
Configuration files for WAN Network Access	a) Change CF: <input type="text" value="MARK"/> , <input type="text" value="ENTER"/> b) Create new CF: <input type="text" value="ENTER"/>
Operations on CFs	Create... or Edit
Create a New File	Name of configuration file: <i>name</i> Select CC type for the KOGS

When you the entries, a submenu to create the configuration file name for the selected CC type appears:

Edit configuration file [<i>name</i>] for <i>cc-type</i>	Select one of the displayed lines
Configuration for WAN Interface <i>no</i>	Local
Configure local network interface	Subnetwork: X.25 Subnet ID: X25-n Own DTE Address: Default transport protocol: NEA
X.25 Parameter for Interface <i>no</i>	Channel ranges for PVCs and SVCs: Attachment to X.25: Transmission speed: X.25 facilities arranged: <i>no</i>

If you have specified *X.25 facilities arranged: yes*, a further menu to create facilities will appear:

X.25 Facilities Arranged for Interface <i>no</i>	Enter special X.25 facilities
Configuration for WAN Interface <i>no</i>	Compile
Configuration for WAN Interface <i>no</i>	Exit

In order to ensure that your configuration entries take effect, you must assign the WAN network access and the generated configuration file to a Communications Controller and load the Communications Controller. See the section “Assigning and loading the configuration file” on page 66.

5.5.2 Defining your own network address

Menu	Choice
CMX Main Menu	Local - Local Host ...
Local Host	NEA Processor: Region:

5.5.3 Defining routes

Menu	Choice
CMX Main Menu	SNPAROUTES - Routes to Remote Subnet Interfaces
Routes to Remote Subnetwork Interfaces	a) Change route: <input type="text" value="MARK"/> , <input type="text" value="ENTER"/> b) Create new route: <input type="text" value="ENTER"/>
Operations on Routes to Remote Subnetwork Interfaces	Create... or Change...
Attributes of a Route	Name: <i>name</i> Type of subnet address: X.25 or PVC Subnet ID: X25-n (must match the subnet ID in the CF) Specify subnetwork address: depends on selected Subnet address type: PVC number or remote DTE address Facilities: no

Menu**Choice**

If you have specified *Facilities: yes*, a further menu to create facilities will appear when you save your entry:

Facilities to Route *name*

Net Protocol ID: NEA (required if neither PVC nor the parameter PROFIL=NEA in the KOGS macro XLTNG was specified)
X.25 Facilities: X.25 facilities that were negotiated with the remote DTE.

5.5.4 Entering partner systems

Menu**Choice**

CMX Main Menu

NSAPs - Remote Hosts ...

Remote Hosts ...

a) Remote Hosts ... Change:

,

b) Remote Hosts ... Create:

Operations on Remote Systems

Create... or Change...

Remote NSAP Information

Name: *name*

Network: NEA

Processor-/Region number:

Subnet Address:

Static route(s)

List of routes: you must specify the name of the route(s) to be used.

5.5.5 Entering transport system applications

This section briefly describes the individual worksteps in the CMX menu system in the form of an overview. A detailed description can be found in the CMX User Guide [1].

Menu	Choice
CMX Main Menu	TSAs - Transport System Applications...
GLOBAL NAME of TS Application	a) Change global name: <input type="text"/> CHOICES, <input type="text"/> ENTER b) Create new global name: specify name part [1] - [5] (all name parts are optional)
Operations on TS Applications	Assign LOCAL NAME... CCP profile: WAN-NX25 T-selector:
Operations on TS Applications	Assign transport address (entry for remote transport system application) CCP profile: WAN-NX25 Station name of TS application: Name of the remote system: p/r CC list: optional

5.6 Examples

This section contains examples to illustrate the configuration of a connection in an NEA network via X.25. The examples include configurations with and without X.25 facilities and also deal with the configuration of multiple transport profiles (including NEA) using X.25.

5.6.1 WAN-NX25 SVC with facilities

TNS entries

```
wan-nx25.application\  
    TA   WANNEA A'nea2test' 1/255
```

FSS entries

```
LOCNSAP ( name=hugo nea-addr=08/15 )  
SNPAROUTES ( name=ro162251 subnet=X25-17 dte-addr=1110000 )  
NSAP ( name=nea2_1_255 nea-addr=1/255 snpa-list=ro162251 )
```

KOGS source file

```
XSYSP  
XSNID   SUBNID = X25-17,  
        ADRTYP = X25_ADR  
XFACI   FACIL = LFAC1,  
        AKFACI = REVCH,  
        PAKLE = 512,  
        PAKLS = 512,  
        WINDE = 7,  
        WINDS = 7  
XLTNG   LPUFADR = 1,  
        PROFIL = NEA,  
        DTEADR = 1590000,  
        UEGSW = 9600,  
        VUEZEIT = 24,  
        X21DEF = DBP,  
        FACIL = LFAC1,  
        SKANALN = 10-20,  
        UEWEG = X25/TYP8 #CCITT X25/1984  
XEND
```

5.6.2 WAN-NX25 PVC without facilities

Difference with respect to SVCs

The X.25 network partner is identified here only by a PVC number in the FSS route and not by a DTE address. This PVC number must be in the PVC range that was defined for the port (with subnet ID X25-19) in the KOGS source. The PVC is uniquely assigned to an X.25 network partner together with a transport profile.

TNS entries

```
wan-nx25..application\  
    TA      WANNEA A'nea2test' 1/255
```

FSS entries

```
LOCNSAP ( name=hugo nea-addr=08/15 )  
SNPAROUTES ( name=rpvc subnet=X25-19 pvc-nr=1 )  
NSAP ( name=nea2_1_255 nea-addr=1/255 snpa-list=rpvc)
```

KOGS source file

```
XSYSP  
XSNID   SUBNID = X25-19,  
        ADRTYP = X25_ADR  
XLTNG   LPUFADR = 2,  
        PROFIL = NEA,  
        DTEADR = 1930000,  
        UEGSW = 9600,  
        VUEZEIT = 24,  
        X21DEF = DBP,  
        PKANALN = 1-10, #Define PVC range here  
        UEWEG = X25/TYP8  
XEND
```

5.6.3 Selecting an alternative network port

Two X.25 ports (1930000, 1950000) are available on the active side, and two X.25 ports (1450000, 1910000) are likewise available on the passive side.

Configuration on the active side

TNS entries

```
A1102001.ak\
    TSEL WANNEA A'A1102001'
F1102001.pa\
    TA   WANNEA A'F1102001' 21/5
```

FSS entries

```
FACIL ( name=faAuwe_1 npid=NEA )
SNPAROUTES ( name=snAuwe_1 subnet=X25-11 dte-addr=1450000 )
SNPAROUTES ( name=snAuwe_2 subnet=X25-11 dte-addr=1910000 )
NSAP ( name=nsPuwe_1 net=NEA nea-addr=21/5
       snpa-list=snAuwe_2+snAuwe_1 )
```

KOGS source file

```
XSYSP
XSNID   SUBNID = X25-11,
        ADRTYP = X25_ADR
XLTNG   DTEADR = 1930000,
        LPUFADR = 1,
        SKANALN = 1-32,
        VUEZEIT = 24,
        UEGSW  = 64000,
        X21DEF = DBP,
        UEWEG  = X25/TYP8
XLTNG   DTEADR = 1950000,
        LPUFADR = 2,
        SKANALN = 1-64,
        VUEZEIT = 24,
        UEGSW  = 64000,
        X21DEF = DBP,
        UEWEG  = X25/TYP8
XEND
```

Configuration on the passive side**TNS entries**

```
F1102001.pa\  
    TSEL WANNEA  A'F1102001'
```

FSS entries

Not relevant

KOGS source file

```
XSYS  
XSNID  SUBNID = X25-4,  
        ADRTYP = X25_ADR  
XLTNG  DTEADR = 1450000,  
        PROFIL = NEA,  
        LPUFADR = 1,  
        SKANALN = 36-64,  
        UEWEG = X25/TYP58,  
        VUEZEIT = 24,  
        UEGSW = 64000,  
        X21DEF = DBP  
XLTNG  DTEADR = 1910000,  
        PROFIL = NEA,  
        LPUFADR = 2,  
        SKANALN = 1-32,  
        UEWEG = X25/TYP58,  
        VUEZEIT = 24,  
        UEGSW = 64000,  
        X21DEF = DBP  
XEND
```

6 The WAN-CONS profile

6.1 Profile description

The WAN-CONS profile enables your system to communicate via a packet switching network (Datex-P, Transpac, PSS, etc.) with other systems such as BS2000/OSD hosts, UNIX systems, and non-SNI systems, which, like WAN-CONS, have implemented the TC1111/1121, TD1111/1121, and TE1111/1121 profiles of ISO/IEC ISP 10609 (previously the T/31 profile of ENV 41104).

The figure below illustrates how your system is connected to a **packet switching network** using the WAN-CONS profile:

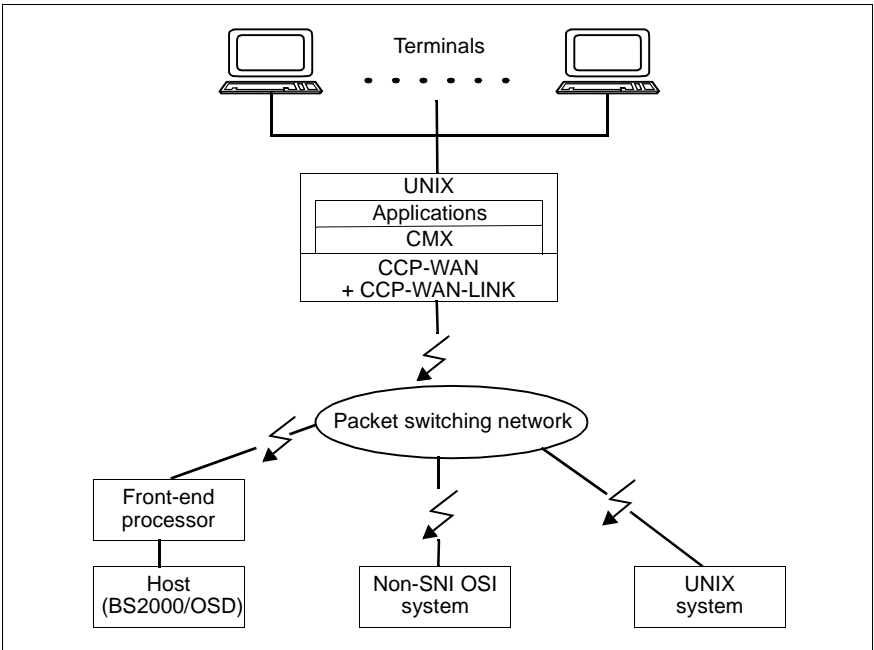

Figure 18: Connection of a UNIX system using the WAN-CONS profile

The operation of the OSI transport protocols IS 8073 Cl.0/2 is supported not only via X.25 networks, but also via telephone and circuit switching networks. This extension allows UNIX systems to be linked via OSI protocols to a group of HICOM systems in an analog network. In such cases, the T.70 protocol is used at level 3 instead of the X.25 protocol. WAN-CONS supports point-to-point configurations via X.21/V.24 (dedicated and switched) lines.

The figure below illustrates how a UNIX system is connected to a **circuit switching network** when using the WAN-CONS profile with the T.70 protocol:

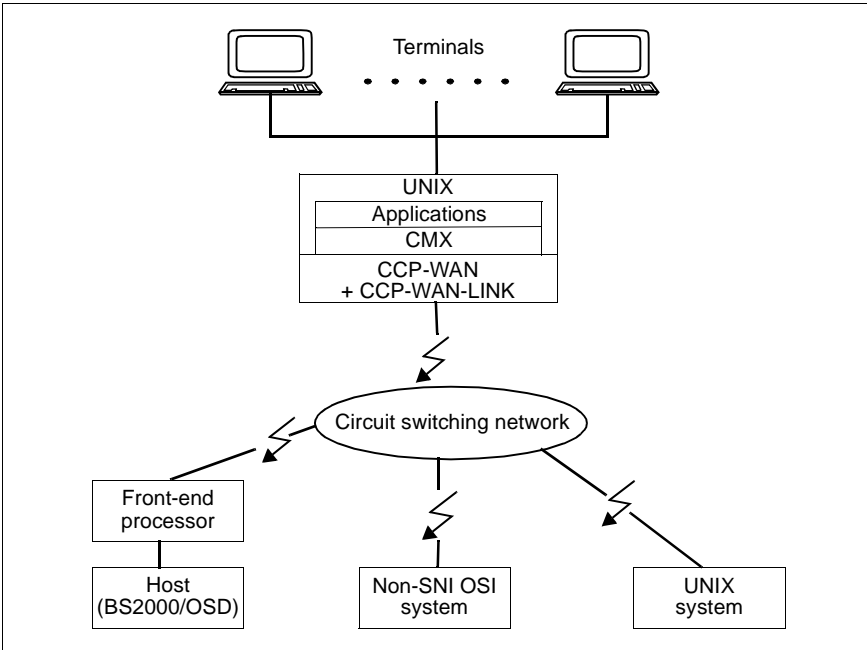

Figure 19: Connection of a UNIX system using the WAN-CONS profile with the T.70 protocol

Transport system protocols

The following protocols are assigned to the WAN-CONS profile on the OSI layers 1 to 4:

Layer	Function	X.25 protocols	T.70 protocols
4	Transport	IS 8073 Cl.0/2 (TP02)	
3	Network	X.25-3	T.70-3
2	Data Link	HDLC-LAPB	HDLC-BAC
1	Physical	X.21/X.21bis	X.21/V.24/V.25bis

Table 21: Transport system protocols for the WAN-CONS profile

6.2 Special operational aspects of WAN-CONS with the T.70 protocol

The following differences must be noted when operating WAN-CONS via dedicated/switched circuits as opposed to X.25 connections:

- In the case of dedicated and switched circuits, the services of telephone and circuit switching networks do not support peer-to-peer transmission of the Transport Protocol Identification (TPID). The network access variant ISO, which corresponds to PROFIL=ISO in the KOGS macro XLTNG, defines the transport protocol ISO 8073 for these networks.
- Furthermore, since telephone and circuit switching networks do not support the transmission of the sender's call number, this cannot be used as a means of identifying the calling partner system (see also the TNS call `t_getname`). Transport system applications that use the CCP profile WAN-CONS with T70-3 must therefore implement the partner identification by some other method (e.g. in the application protocols) if required.

The dedicated or switched connections configured with PROFIL=ISO are dedicated to the CCP profile WAN-CONS with the T.70 protocol. In other words, WAN-NEA cannot be used simultaneously via the same dedicated or switched line.

6.3 KOGS, FSS and TNS parameters

The following sections contain lists that show which of the specified parameters and value ranges for KOGS macros and for the FSS and TNS databases presented in the chapter “Configuration with KOGS macros” on page 223 may be used for the WAN-CONS profile. A description of the FSS parameters can be found in the chapter “FSS configuration” on page 269. The TNS is described in the “CMX, Operation and Administration” User Guide [1].

WAN-CONS with the T.70 protocol

If you want to use the WAN-CONS profile with the T.70 protocol, the values specified for WAN-NEA apply (see the section “KOGS, FSS and TNS parameters” on page 82).

6.3.1 KOGS parameters

The meanings of the individual macros and operands listed below can be found in the chapter “Configuration with KOGS macros” on page 223.

Macro	Operands	Operand values
XEND		
XFACI	[AKFACI]	<u>NOREVCH</u> REVCH FASTSEL <i>list</i>
	[DTEADCA]	JA (YES) TOANPI <i>list</i>
	FACIL	<i>name</i> max. 7 characters
	[PAKLE]	16... <u>128</u> ...2048 (power of 2)
	[PAKLS]	16... <u>128</u> ...2048 (power of 2)
	[PAKNUM]	<u>MOD8</u> MOD128

Table 22: KOGS parameters for the WAN-CONS profile

Macro	Operands	Operand values
	[R20]	1... <u>10</u> ...128
	[R22]	1... <u>10</u> ...128
	[R23]	1... <u>2</u> ...128
	[T20]	1... <u>10</u> ...2048
	[T21]	1... <u>200</u> ...2048
	[T22]	1... <u>10</u> ...2048
	[T23]	1... <u>10</u> ...2048
	[T24]	<u>0</u> ...2048
	[T25]	0... <u>180</u> ...2048
	[WINDE]	PAKNUM = MOD8: 1... <u>2</u> ...7 PAKNUM = MOD128: 1... <u>2</u> ...127
	[WINDS]	PAKNUM = MOD8: 1... <u>2</u> ...7 PAKNUM = MOD128: 1... <u>2</u> ...127
XLTNG	[DTEADR]	<i>decimal number</i>
	[DUETYP]	<u>MODEM</u>
	[FACIL]	<i>name max. 7 characters</i>
	[FRMRANZ]	0... <u>2</u> ...255
	LPUFADR	1...4
	[MAXIFL]	1... <u>4096</u> .
	[PKANALN]	0...4095-0...4095
	[PROFIL]	ISO
	[PRTIMER]	3000...60000
	[PRTIM2]	100... <u>3000</u>
	[PRTIM3]	<u>0</u> ...65000
	[RCB]	<u>0</u> ...65535
	[SKANABG]	1...4095-1...4095
	[SKANALN]	1...4095-1...4095
	[SKANANK]	1...4095-1...4095
	[TPAUSE]	<u>NEIN</u> (NO), JA (YES)

Table 22: KOGS parameters for the WAN-CONS profile

Macro	Operands	Operand values
	[UEGSW]	2400...64000
	UEWEG	X25/TYP5, X25/TYP6, X25/TYP8, X25/TYP9, X25/TYP56, X25/TYP58
	[VUEZEIT]	0... <u>24</u> ...127
	[V24DEF]	STD
	[WDHZAEHL]	0... <u>3</u> ...255
	[X21DEF]	<u>DBP</u>
XSNID	ADR TYP	X25_ADR or X25-ADR
	SUBNID	X25-i, i=1...32
XSYSP		

Table 22: KOGS parameters for the WAN-CONS profile

WAN-CONS with the T.70 protocol

If you want to use the WAN-CONS profile with the T.70 protocol, the values specified for WAN-NEA apply (see the section “KOGS, FSS and TNS parameters” on page 82), but with the following differences:

Macro	Operands	Operand values
XLTNG	PROFIL	ISO (This entry is mandatory!)
	[RUF]	AUTO AUTO/ANK, AUTO/ABG
	[VUEZEIT]	dropped
	[MLNK]	dropped

Table 23: KOGS parameters for the WAN-CONS profile with the T.70 protocol

6.3.2 FSS parameters

For more information on the individual object classes and attributes, see chapter “FSS configuration” on page 269.

FSS entries are required only if

- you have agreed on using facilities with your remote X.25 partner. You must then create a FACIL object and an SNPAROUTES object in which you reference that FACIL object.
- there is no CC list specified in the TNS entry and several subnet ports exist.
- WAN-CONS with the T.70 protocol is connected to a telephone network.

Object class FACIL: Define facilities

No FACIL entries are required for WAN-CONS with the T.70 protocol.

The following applies to WAN-CONS with the X.25 protocol:

Attribute	Format	Meaning
name	1-15 characters comprising letters, digits, and the special characters _ and #. A distinction is made between uppercase and lowercase. The first character must not be a digit or an underscore ‘_’.	Name of the FACIL object
facil	See <i>name</i>	Name of another FACIL object that is referenced
npid	OSI-CONS	Network protocol ID
x25-octet-string	1...109 octets in hex format	DTE facilities in accordance with CCITT X.25 Annex G (IS8208)
x25-packet-size	Send direction[/receive direction] with the individual values for S/R: 16 32 64 128 256 512 1024 2048. If R is not specified, R=S.	Packet size

Table 24: Attributes of the FACIL object class

Attribute	Format	Meaning
x25-window-size	Send direction[/receive direction] with the individual values for S/R 1-7, if XFACI PAKNUM=MOD8 1-127, if XFACI PAKNUM=MOD128	Window size
x25-throughput	Send direction[/receive direction] with the individual values for S/R in Kbit/s: 2,4 4,8 9,6 19,2 48 64	Throughput class
x25-cug	0-9999. Leading zeros are evaluated: 1-2-digit input means 'basic format'; 3-4-digit input means 'extended format'.	Selection of a closed user group
x25-cug-oa	0-9999. See <i>x25-cug</i>	Selection of a closed user group with unrestricted outgoing call
x25-bcug	0-9999. Leading zeros are not evaluated. The "extended format" must always be used.	Selection of a bilaterally closed user group
x25-revch	B[OTH_REQ_AND_ACC] R[EQUEST_ONLY] A[CCEPT_ONLY] N[EITHER_REQ_NOR_ACC]	Request reverse charges or accept request for reversed charges
x25-transit-delay	0-65534 milliseconds	Desired transmission time
x25-fast-select	N[O-RESTRICTION] R[ESTRICTION]	Fast select (short dialog using the Call User Data field)
x25-rpoa	DNIC[+DNIC...] with a maximum of 12 elements	Selection of a route via one (or more) transit networks identified by their DNIC (Data Network Identification Code)

Table 24: Attributes of the FACIL object class

Attribute	Format	Meaning
x25-nui	Max. 16 printable characters (ASCII, EBCDIC) or 16 hexadecimal character pairs: Format: <i>formind:nui-value</i> formind = A E X	Network User Identification

Table 24: Attributes of the FACIL object class

Object class LOCNSAP: Local host and object class SUBNET: Local subnet interface

No separate LOCNSAP entries are necessary for WAN-CONS.

However, you can configure a local OSI-NSAP which is specified in the DTE facilities when the X.25 connection is established. This is only the case if you have entered the remote NSAP in the TNS.

There are two different ways of configuring a local NSAP:

- for the entire system as an attribute of object class LOCSNAP (see section „LOCNSAP object class“ on page 280)
- as a subnet-specific attribute of object class SUBNET (see section „SUBNET object class“ on page 287).
You can generate a separate local NSAP for each subnet ID.

These two possibilities are both available.

When a connection is established via a given X.25 subnet then the NSAP generated for this subnet is entered as a local NSAP in the DTE facilities.

If there is no NSAP for the corresponding network then the default value – if one exists – of the NSAP generated with the LOCNSAP is used.

Object class NSAP: Remote service access point

No NSAP entries are necessary for WAN-CONS – even in the case of the X.25 and T.70 protocols.

However, when you address the partner application in the TNS, you have the option of not specifying the subnet address of the partner system or specifying it together with the associated OSI-NSAP address (see section „TNS parameters“ on page 132). If you have only specified the NSAP address in the TNS

then you must use the FSS to create an NSAP object with the same address. This NSAP object in turn references an object of class SNPAROUTES which can be used to establish the connection in the subnet.

If you specify an NSAP in the TNS then this remote NSAP is communicated to the so-called DTE facilities when an X.25 connection is established.

Object class SNPAROUTES: Routes

Association between subnet address type and subnet ID

Depending on the subnet address type, you can assign the subnet ID as follows:

Subnet addr. type	Subnet ID
X25 PVC	X25-x
X21 X21DIRECT	X21-x (for T.70)
PT (Public Telephone)	PT-x (for T.70)

Table 25: Assignment of subnet ID to subnet address type

The following applies to WAN-CONS with the X.25 protocol:

Attribute	Format	Meaning
name	1-15 characters comprising letters, digits, and the special characters _ and #. A distinction is made between uppercase and lowercase. The first character must not be a digit or an underscore '_'.	Name of the SNPAROUTES object
facil	See <i>name</i>	Name of a FACIL object
dte-addr*	1-17 decimal digits	Remote X.25 DTE address
pvc-nr*	<i>pvc</i> [/ <i>dte</i>] <i>pvc</i> : decimal number (0 ... 4095) <i>dte</i> : 1-17 decimal digits	X.25 PVC number and associated local DTE address
type	X25 PVC	Subnet address type

Table 26: Attributes of the SNPAROUTES (X.25) object class

Attribute	Format	Meaning
subnet	X25- <i>n</i> <i>n</i> = 1, .., 32	Subnet ID

Table 26: Attributes of the SNPAROUTES (X.25) object class

* The “dte-addr” and “pvc-nr” attributes are mutually exclusive. The implicit types for the “pvc-nr” and “dte-addr” entries are “type=PVC” and “type=X25”, respectively.

The following applies to WAN-CONS with the T.70 protocol:

Attribute	Format	Meaning
name	1-15 characters comprising letters, digits, and the special characters _ and #. A distinction is made between uppercase and lowercase. The first character must not be a digit or an underscore ‘_’.	Name of the SNPAROUTES object
dial-nr*	<i>dial-no</i> DIRECT/ <i>dial-no</i> <i>dial-no</i> : 1-24 decimal digits or any 1-24 any visible characters enclosed in single quotes (')	Remote X.21 call number. In the case of “Direct Mode”: local X.21 call number.
phone-nr*	<i>phone-no</i> <i>phone-no</i> : 1-24 decimal digits or any 1-24 any visible characters enclosed in single quotes (')	Telephone number
type	X21 X21DIRECT PT	Subnet address type
subnet	X21- <i>n</i> PT- <i>n</i> <i>n</i> = 1, .., 32	Subnet ID

Table 27: Attributes of the SNPAROUTES (T.70) object class

* The “dial-nr” and “phone-nr” attributes are mutually exclusive.

6.3.3 TNS parameters

In order to use the WAN-CONS profile, you must specify the LOCAL NAMES (T-selectors) of the transport system applications as well as the TRANSPORT ADDRESSES in the CMX menu. This must be done with the address format WANSBKA.

Note that it is not possible to specify the TPID when entering the TRANSPORT ADDRESSES for dedicated and switched lines (see the section “Special operational aspects of WAN-CONS with the T.70 protocol” on page 123). Furthermore, when operating WAN-CONS via multiple ports, the Communications Controller and the line numbers must be specified in order to select the appropriate port.

More information on the TNS and on the TNS entries for the program interface can be found in the “CMX, Operation and Administration” User Guide [1].

TNS entries for the local application:

Global name	Type	Addr. format	T-selector
<i>Global name</i>	TSEL	WANSBKA	{T A E X} string <i>string</i> with max. 8 characters after T

TNS entries for the remote application:

Global name	Type	Addr. format	Addr. component
<i>Global name</i>	TA	WANSBKA	X.121 x.25-dte address (17 positions) or PVC <i>pvc number</i> or E.163 <i>phone number</i> (for protocol T.70) or X.21 x.21 <i>call number</i> (for protocol T.70) or osi-nsap-address (for X.25) {T A E X} string <i>string</i> with max. 8 characters after T <i>string</i> with max. 32 characters after A, E and X [TPI] [TPC] [WAN cc-no:line identifier]

Depending on which applications expand on the CMX, session components (SSEL) and presentation components (PSEL) may be specified. See the “CMX, Operation and Administration” User Guide [1] for details.

6.4 Configuration using the menu system

This section describes configuration using the menu system *CMXCUI*.

6.4.1 Configuring the local subnetwork interface

Menu	Choice
CMX Main Menu	CFs - CCP Configuration Files ...
Select Network Access	WAN
Configuration Files for WAN Network Access	a) Change CF: <input type="text" value="MARK"/> , <input type="text" value="ENTER"/> b) Create new CF: <input type="text" value="ENTER"/>
Operations on CFs	Create... or Edit
Create a New File	Name of configuration file: <i>name</i> Select CC type for KOGS

When you the entries, a submenu to create the configuration file *name* for the selected CC type appears:

Edit configuration file [<i>name</i>] for <i>cc-type</i>	Select one of the displayed lines
Configuration for WAN Interface <i>no</i>	Local
Configure local network interface	Subnetwork: X.25 (for WAN-CONS via X.25) Subnetwork: X.21 dial-up line, dedicated line, or telephony (for WAN-CONS via T.70) Subnet ID : Own DTE address: [Own X.21 call number] [Own telephone number] Default transport protocol: ISO

If you have entered X.25 for "Subnetwork", you must fill in the following menu, i.e. "X.25 Parameters for Interface *no*", and possibly also the submenu " X.25 Facilities Arranged for Interface *no*".

If you have entered X.21 dial-up line, dedicated line or telephony for “Subnetwork”, you must also fill in the following menu, i.e. “Parameters for Interface *no* to *network*”.

Configuration for WAN Interface *no* Compile

Configuration for WAN Interface *no* Exit

In order to ensure that your configuration entries take effect, you must assign the WAN network access and the generated configuration file to a Communications Controller and load the Communications Controller. See the section „Assigning and loading the configuration file“ on page 66.

6.4.2 Defining routes

Menu

CMX Main Menu

Routes to Remote Subnetwork Interfaces

Operations on Routes to Remote Subnetwork Interfaces

Attributes of a Route

Choice

SNPAROUTES - Routes to Remote Subnetwork Interfaces

a) Change route: ,

b) Create new route:

Create... or Change...

Name: *name*

Type of remote subnet address: X.25 or PVC

Subnet ID:

(must match the subnet ID in the CF)

Specify subnetwork address:

Subnet address: PVC number or X.25-DTE address

Facilities:

If you have specified *Facilities: yes*, a further menu to create facilities will appear when you save your entry:

Facilities to Route [*name*]

Net Protocol ID: OSI-CONS

X.25 Facilities: X.25 facilities that were negotiated with the remote DTE.

6.4.3 Entering partner systems

You are not required to make any entries for your partner system.

6.4.4 Entering transport system applications

This section briefly describes the individual worksteps in the CMX menu system in the form of an overview. A detailed description can be found in the "CMX, Operation and Administration" User Guide [1].

In the case of an outgoing transport connection setup, the preferred or alternative transport protocol class (class 0 or class 2) can be defined by the TNS entries. If there is no corresponding entry in the TNS, class 2 is proposed by TP02 as the preferred and alternative class.

Menu	Choice
CMX Main Menu	TSAs - Transport System Applications
GLOBAL NAME of TS Application	a) Change global name: <input type="text" value="CHOICES"/> , <input type="text" value="ENTER"/>
	b) Create new global name: specify name part [1] - [5] (all name parts are optional)
Operations on TS Applications	Assign LOCAL NAME... CCP profile: WAN-CONS T-selector of the TS application
Operations on TS Applications	Assign transport address... (entry for remote transport system application) CCP profile: WAN-CONS OSI-NSAP address X.25 DTE address: X.21 call number (for T.70) CC list: Protocol identifier: Transport protocol class

6.5 Examples

This section contains examples to illustrate the configuration of the WAN-CONS profile via X.25 and T.70. It also deals with the configuration of multiple transport profiles (including OSI) via X.25.

6.5.1 WAN-CONS SVC without facilities

Differences with respect to NX25 with SVC

The address format is WANSBKA, and the remote transport partner is accessed via the SNPA address by default (i.e the DTE address in this case).

In this case, no NSAP entry is required for the FSS. An SNPAROUTES entry that assigns the DTE address to the subnet ID is sufficient here.



It is (also) possible to enter the NSAP of the remote transport system in the TNS. However, the remote transport system is only addressed via the NSAP if no DTE address is specified. In this case, a route must be created for this NSAP in the FSS. Regardless of the addressing type involved, an NSAP that has been entered in the TNS is included together with a possible local NSAP (entered in the FSS) as so-called DTE facilities when the network connection is set up.

TNS entries for the remote application

```
osi-x25.application\  
    TA WANSBKA X.121 1110000 A'osiltest'
```

FSS entries

```
SNPAROUTES ( name=ro081602 subnet=X25-17 dte-addr=1110000 )
```

KOGS source file

```

XSYSP
XSNID   SUBNID = X25-17,
        ADRTYP = X25_ADR
XLTNG   LPUFADR = 1,
        PROFIL = ISO,
        DTEADR = 1590000,
        UEGSW = 9600,
        X21DEF = DBP,
        SKANALN = 10-20,
        UEWEG = X25/TYP8
XEND

```

6.5.2 WAN-CONS SVC with facilities**TNS entries**

```

osi-x25..application.rw\
        TA      WANSBKA X.121 1110000 A'ositest'

```

FSS entries

```

FACIL ( name=fa084959 x25-revch=REQUEST_ONLY)
SNPAROUTES ( name=ro085011 subnet=X25-17 dte-addr=1110000
             facil=fa084959 )

```

KOGS source file

```

XSYSP
XSNID   SUBNID = X25-17,
        ADRTYP = X25_ADR
XLTNG   LPUFADR = 1,
        PROFIL = ISO,
        DTEADR = 1110000,
        UEGSW = 9600,
        X21DEF = DBP,
        SKANALN = 10-20,
        UEWEG = X25/TYP8
XEND

```

6.5.3 WAN-CONS via a dedicated line (T.70)

The KOGS parameters correspond to those for an NEA dedicated line. The address format WANSBKA must be specified for the TNS, but no NSAP entry is required for the FSS. The remote partner is identified by means of the designated line number and controller.

TNS entries

```
W12_2 TSEL WANSBKA T'W12A1'  
W12_1 TA WANSBKA T'W12A2' WAN 2:1
```

KOGS source file

```
XSYSP  
XSNID SUBNID = PP-1,  
      ADRTYP = HDLCPP  
XLTNG LPUFADR = 1,  
      PROFIL = ISO,  
      DUETYP = MODEM,  
      NRZI = JA,  
      PRTIM2 = 500,  
      TPAUSE = JA,  
      UEGSW = 64000,  
      UEWEG = FE-STAND/4DR,  
      WDHZAEL = 3,  
      X21DEF = DBP  
XPRO LINKADR = (3,1)  
XEND
```

6.5.4 WAN-CONS via a dial-up line (T.70)

The address format WANSBKA must be specified for the TNS, but no NSAP entry is required for the FSS. In the SNPAROUTES object you must specify the **local** telephone number.

TNS entries

```
W12_2 TSEL WANSBKA T'W12A1'
W12_1 TA WANSBKA E.163 987654 T'W12A2'
```

FSS entries

```
FACIL ( name=osi_faci npid=OSI-CONS )
SNPAROUTES ( name=w2_11 subnet=PT-1 phone-nr=4181
              facil=osi_faci )
```

KOGS source file

```
XSYSP
XSNID SUBNID = PT-1,
      ADRTYP = PT_ADR
XLTNG DUETYP = MODEM,
      LPUFADR = 1,
      PLIDENT = NEIN,
      PROFIL = ISO,
      NRZI = NEIN,
      PRTIM2 = 500,
      RUF = AUTO,
      RUFNUM = 4181,
      RUFPAUS = 6,
      RUFWDH = 3,
      UEGSW = 2400,
      UEWEG = FE-WAHL/4DR,
      UEKONF = PZP,
      UEPROZ = HDLC/BAC,
      VUEZEIT = 24,
      V24DEF = STD,
      WDHZAEI = 3
XEND
```

6.5.5 Selecting an alternative network port

Two X.25 ports (1930000, 1950000) are available on the active side. On the passive side, the X.25 port (1450000) is to be available.

Configuration on the active side

TNS entries

```
uwe.ak\  
    TSEL WANSBKA  A'A1102001'  
uwe.pa\  
    TA  WANSBKA  X.121 1450000 A'F1102001' 2/2
```

FSS entries

```
SNPAROUTES ( name=snAuwe_1 subnet=X25-20 dte-addr=1450000 )  
SNPAROUTES ( name=snAuwe_2 subnet=X25-21 dte-addr=1450000 )
```

KOGS source file

```
XSYSP  
XSNID  SUBNID = X25-20,  
        ADRTYP = X25_ADR  
XLTNG  DTEADR = 1930000,  
        LPUFADR = 1,  
        SKANALN = 1-32,  
        UEWEG = X25/TYP8,  
        VUEZEIT = 24,  
        UEGSW = 64000,  
        X21DEF = DBP,  
        UEPROZ = HDLC/LAPB,  
        MODE = SIE  
  
XSNID  SUBNID = X25-21,  
        ADRTYP = X25_ADR  
  
XLTNG  DTEADR = 1950000,  
        LPUFADR = 2,  
        SKANALN = 1-64,  
        UEWEG = X25/TYP8,  
        VUEZEIT = 24,  
        UEGSW = 64000,  
        X21DEF = DBP,  
        UEPROZ = HDLC/LAPB,  
        MODE = SIE  
  
XEND
```

Configuration on the passive side**TNS entries**

```
uwe.pa\  
    TSEL WANSBKA A'F1102001'
```

FSS entries

Not relevant

KOGS source file

```
XSYS  
XSNID  SUBNID = X25-21,  
        ADRTYP = X25_ADR  
XLTNG  DTEADR = 1450000,  
        LPUFADR = 1,  
        SKANALN = 36-64,  
        UEWEG = X25/TYP58,  
        VUEZEIT = 24,  
        UEGSW = 64000,  
        X21DEF = DBP,  
        UEPROZ = HDLC/LAPB,  
        MODE = SIE  
XEND
```

Notes/Warnings:

Different ports with PVCs must be configured with different subnet IDs.

7 The WAN-X25 profile

7.1 Profile description

The WAN-X25 profile allows you to integrate your system in different networks via a packet switching network (Datex-P, Transpac, PSS, etc.) or to communicate with non-SNI systems. The connection is made without a transport protocol. This profile can be used to establish a connection to a TCP/IP network via an X.25 subnetwork and to set up connections to an SNA network, for example, and also to communicate with private X.25 applications.

The following two communication options are discussed in the sections below:

- X.25 applications. (This also includes SNA applications via X.25.)
- TCP/IP via X.25

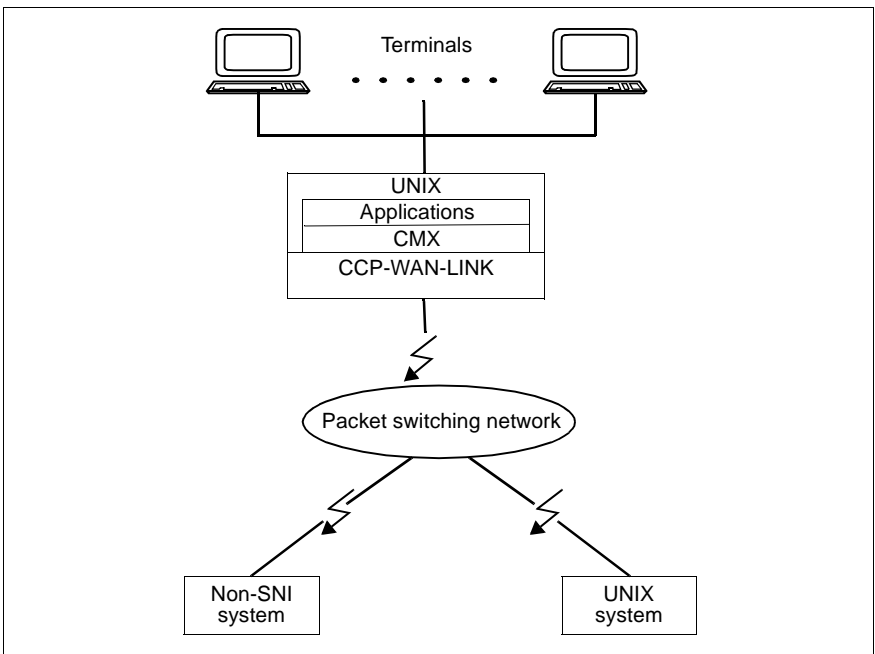

Figure 20: Connection of a UNIX system using the WAN-X25 profile

Transport system protocols

The WAN-X25 profile uses the null transport provider. The following protocols are assigned to the WAN-X25 profile at OSI layers 1 to 4:

Layer	Function	Protocols
4	Transport	No protocol
3	Network	X.25-3
2	Data Link	HDLC-LAPB
1	Physical	X.21/X.21bis

Table 28: Transport system protocols for the WAN-X25 profile

7.2 KOGS, FSS and TNS parameters

The following sections contain lists that show which of the specified parameters and value ranges for KOGS macros and for the FSS and TNS data bases that are presented in the Chapter „Configuration with KOGS macros“ on page 223 can be used for the WAN-X25 profile. A description of the FSS parameters can be found in the Chapter „FSS configuration“ on page 269. The TNS is described in the “CMX, Operation and Administration” User Guide [1].

7.2.1 KOGS parameters

The same KOGS parameters are used in all three cases, i.e. for X.25 applications, TCP/IP via X.25, and SNA applications via X.25.

The meanings of the individual macros and operands listed below can be found in the Chapter „Configuration with KOGS macros“ on page 223.

Macro	Operands	Operand values
XEND		
XFACI	[AKFACI]	<u>NOREVCH</u> REVCH FASTSEL <i>list</i>
	[DTEADCA]	JA (YES) TOANPI <i>list</i>
	FACIL	<i>name</i> max. 7 characters
	[PAKLE]	16... <u>128</u> ...2048 (power of 2)
	[PAKLS]	16... <u>128</u> ...2048 (power of 2)
	[PAKNUM]	<u>MOD8</u> MOD128
	[R20]	1... <u>10</u> ...128
	[R22]	1... <u>10</u> ...128

Table 29: KOGS parameters for the WAN-X25 profile

Macro	Operands	Operand values
	[R23]	1... <u>2</u> ...128
	[T20]	1... <u>10</u> ...2048
	[T21]	1... <u>200</u> ...2048
	[T22]	1... <u>10</u> ...2048
	[T23]	1... <u>10</u> ...2048
	[T24]	<u>0</u> ...2048
	[T25]	0... <u>180</u> ...2048
	[WINDE]	PAKNUM = MOD8: 1... <u>2</u> ...7 PAKNUM = MOD128: 1... <u>2</u> ...127
	[WINDS]	PAKNUM = MOD8: 1... <u>2</u> ...7 PAKNUM = MOD128: 1... <u>2</u> ...127
XLTNG	[DTEADR]	<i>decimal number</i>
	[DUETYP]	<u>MODEM</u>
	[FACIL]	<i>name</i> max. 7 characters
	[FRMRANZ]	0... <u>2</u> ...255
	LPUFADR	1...4
	[MAXIFL]	1... <u>4096</u>
	[PKANALN]	Only for PVC: 0...4095
	[PROFIL]	NTP - PPP
	[PRTIMER]	3000...60000
	[PRTIM2]	100... <u>3000</u>
	[PRTIM3]	<u>0</u> ...65000
	[RCB]	<u>0</u> ...65535
	[SKANABG]	1...4095-1...4095
	[SKANALN]	1...4095-1...4095
	[SKANANK]	1...4095-1...4095
	[TPAUSE]	<u>NEIN</u> (NO), JA (YES)
	[UEGSW]	2400...2048000

Table 29: KOGS parameters for the WAN-X25 profile

Macro	Operands	Operand values
	UEWEG	X25/TYP5, X25/TYP6, X25/TYP8, X25/TYP9, X25/TYP56, X25/TYP58
	[VUEZEIT]	0... <u>24</u> ...127
	[V24DEF]	STD
	[WDHZAEHL]	0... <u>3</u> ...255
	[X21DEF]	<u>DBP</u>
XSNID	ADRTYP	X25_ADR or X25-ADR for X.25 ports
	SUBNID	X25-i, i=1...32 for X.25 subnetwork ports
XSYSP		

Table 29: KOGS parameters for the WAN-X25 profile

7.2.2 FSS parameters for X.25 applications and SNA applications via X.25

For more information on the individual object classes and attributes, see chapter “FSS configuration” on page 269.

FSS entries are required only if

- you have agreed on using facilities with your remote X.25 partner. You must then create a FACIL object and an SNPAROUTES object in which you reference that FACIL object.
- there is no CC list specified in the TNS entry and several subnetwork ports exist.

Object class FACIL: Define facilities

Attribute	Format	Meaning
name	1-15 characters comprising letters, digits, and the special characters _ and #. A distinction is made between uppercase and lowercase. The first character must not be a digit or an underscore '_'. .	Name of the FACIL object
facil	See <i>name</i>	Name of another FACIL object that is referenced
npid	PRIVATE	Network protocol ID
x25-octet-string	1...109 octets in hex format	DTE facilities in accordance with CCITT X.25 Annex G (IS8208)
x25-packet-size	Send direction[/receive direction] with the individual values for S/R: 16 32 64 128 256 512 1024 2048. If R is not specified, R=S.	Packet size
x25-window-size	Send direction[/receive direction] with the individual values for S/R 1-7, if XFACI PAKNUM=MOD8 1-127, if XFACI PAKNUM=MOD128	Window size
x25-throughput	Send direction[/receive direction] with the individual values for S/R in Kbit/s: 2,4 4,8 9,6 19,2 48 64	Throughput class
x25-cug	0-9999. Leading zeros are evaluated: 1-2-digit input means 'basic format'; 3-4-digit input means 'extended format'.	Selection of a closed user group

Table 30: Attributes of the FACIL object class

Attribute	Format	Meaning
x25-cug-oa	0-9999. See <i>x25-cug</i>	Selection of a closed user group with unrestricted outgoing call
x25-bcug	0-9999. Leading zeros are not evaluated. The “extended format” must always be used.	Selection of a bilaterally closed user group
x25-revch	B[OTH_REQ_AND_ACC] R[EQUEST_ONLY] A[CCEPT_ONLY] N[EITHER_REQ_NOR_ACC]	Request reverse charges or accept request for reversed charges
x25-transit-delay	0-65534 milliseconds	Desired transmission time
x25-fast-select	N[O-RESTRICTION] R[ESTRICTION]	Fast select (short dialog using the Call User Data field)
x25-rpoa	DNIC[+DNIC...] with a maximum of 12 elements	Selection of a route via one (or more) transit networks identified by their DNIC (Data Network Identification Code)
x25-nui	Max. 16 printable characters (ASCII, EBCDIC) or max. 16 hexadecimal digit pairs: Format: <i>formind:nui-value</i> formind = A E X	Network User Identification

Table 30: Attributes of the FACIL object class

Object class LOCNSAP: Local host

No separate LOCNSAP entries are required when configuring X.25 applications and SNA applications via X.25.

Object class NSAP: Remote network service access points

If you are configuring X.25 applications or SNA applications via X.25, you need not define the network addresses of the partners. No NSAP entries are required.

Object class SNPAROUTES: Routes

Association between subnet address type and subnet ID

Depending on the subnet address type, you can assign the subnet ID as follows:

Subnet addr. type	Subnet ID
X25 PVC	X25-x

Table 31: Assignment of subnet ID to subnet address type

Attribute	Format	Meaning
name	1-15 characters comprising letters, digits, and the special characters _ and #. A distinction is made between uppercase and lowercase. The first character must not be a digit or an underscore '_'. _	Name of the SNPAROUTES object
dte-addr*	1-17 decimal digits	Remote X.25 DTE address
pvc-nr*	<i>pvc</i> [/ <i>dte</i>] <i>pvc</i> : decimal number (0 ... 4095) <i>dte</i> : 1-17 decimal digits	X.25-PVC number and associated local DTE address
facil	See <i>name</i>	Name of a FACIL object
subnet	X25- <i>n</i> <i>n</i> = 1, ..., 32	Subnet ID

Table 32: Attributes of the SNPAROUTES object class

* The “dte-addr” and “pvc-nr” attributes are mutually exclusive. The implicit types for the “pvc-nr” and “dte-addr” entries are “type=PVC” and “type=X25”, respectively“.

7.2.3 FSS parameters for TCP/IP via X.25

For more information on the individual object classes and attributes, see chapter “FSS configuration” on page 269.

Object class FACIL: Define facilities

Attribute	Format	Meaning
name	1-15 characters comprising letters, digits, and the special characters _ and #. A distinction is made between uppercase and lowercase. The first character must not be a digit or an underscore '_’.	Name of the FACIL object
facil	See <i>name</i>	Name of another FACIL object that is referenced
npid	NEA	Network protocol ID
x25-octet-string	1...109 octets in hex format	DTE facilities in accordance with CCITT X.25 Annex G (IS8208)
x25-packet-size	Send direction[/receive direction] with the individual values for S/R: 16 32 64 128 256 512 1024 2048. If R is not specified, R=S.	Packet size
x25-window-size	Send direction[/receive direction] with the individual values for S/R: 1-7, if XFACI PAKNUM=MOD8 1-127, if XFACI PAKNUM=MOD128	Window size

Table 33: Attributes of the FACIL object class

Attribute	Format	Meaning
x25-throughput	Send direction[/receive direction] with the individual values for S/R in Kbit/s: 2,4 4,8 9,6 19,2 48 64	Throughput class
x25-cug	0-9999. Leading zeros are evaluated: 1-2-digit input means 'basic format'; 3-4-digit input means 'extended format'.	Selection of a closed user group
x25-cug-oa	0-9999. See <i>x25-cug</i>	Selection of a closed user group with unrestricted outgoing call
x25-bcug	0-9999. Leading zeros are not evaluated. The "extended format" must always be used.	Selection of a bilaterally closed user group
x25-revch	B[OTH_REQ_AND_ACC] R[EQUEST_ONLY] A[CCEPT_ONLY] N[EITHER_REQ_NOR_ACC]	Request reverse charges or accept request for reversed charges
x25-transit-delay	0-65534 milliseconds	Desired transmission time
x25-fast-select	N[O-RESTRICTION] R[ESTRICTION]	Fast Select (short dialog using the Call User Data field)
x25-rpoa	DNIC[+DNIC...] with a maximum of 12 elements	Selection of a route via one (or more) transit networks identified by their DNIC (Data Network Identification Code)
x25-nui	Max. 16 printable characters (ASCII, EBCDIC) or max. 16 hexadecimal digit pairs: Format: <i>formind:nui-value</i> formind = A E X	Network User Identification

Table 33: Attributes of the FACIL object class

Attribute	Format	Meaning
compress	T[CP/IP] N[O]	Van-Jacobsen header compression
admit	B[OTH_IN_AND_OUT] O[UTGOING_ONLY] I[NCOMING_ONLY] N[EITHER_IN_NOR_OUT]	Access protection at the subnetwork level

Table 33: Attributes of the FACIL object class

Object class LOCNSAP: Local host

No separate LOCNSAP entries are required for TCP/IP via X.25.

Object class NSAP: Remote network access point

Attribute	Format	Meaning
name	1-32 printable and visible characters	Name of the NSAP object
internet-addr	<i>nr.nr.nr.nr</i> <i>nr</i> : decimal number 0...255	32-bit Internet NSAP address
net*	INTERNET	Network used by the local system to reach the NSAP
access*	DIRECT	Access to the SNPA address via which the NSAP can be reached
snpa-list	<i>snpa+snpa+...+snpa</i> with max. 20 list elements. <i>snpa</i> : <i>name</i> <i>name/weight</i> <i>name</i> : see <i>name</i> under SNPAROUTES <i>weight</i> : digit from 1-20	List of alternative SNPAROUTES objects that can be used to reach this NSAP. The priority can be specified with a value for <i>weight</i> (20 is the highest priority).
type	X21 PP X21DIRECT PT	Subnet address type

Table 34: Attributes of the NSAP object class

Attribute	Format	Meaning
subnet	X25- <i>n</i> <i>n</i> = 1, ..., 32	Subnet ID

Table 34: Attributes of the NSAP object class

* The “net” and “access” attributes need not be specified in the configuration file or in the *create* command (*fssadm create NSAP...*), since they are implicitly derived from other attributes.

Object class SNPAROUTES: Routes

Association between subnet address type and subnet ID

Depending on the subnet address type, you can assign the subnet ID as follows:

Subnet addr. type	Subnet ID
X25 PVC	X25-x

Table 35: Assignment of subnet ID to subnet address type

Attribute	Format	Meaning
name	1-15 characters comprising letters, digits, and the special characters <code>_</code> and <code>#</code> . A distinction is made between uppercase and lowercase. The first character must not be a digit or an underscore <code>'_'</code> .	Name of the SNPAROUTES object
facil	See <i>name</i>	Name of a FACIL object
rem-snpa*	See <i>name</i>	Name of a REMSNPA object that represents the remote subnetwork address
subnet	X25- <i>n</i> <i>n</i> = 1, ..., 32	Subnet ID

Table 36: Attributes of the SNPAROUTES object class

* Alternatively, one of the SNPA addresses (“dte-addr”, “pvc-nr”) listed under the REMSNPA object class may be directly specified.

7.2.4 TNS parameters

Detailed information on the TNS and on the TNS entries for the program interface can be found in the “CMX, Operation and Administration” User Guide [1].

TNS parameters for X.25 applications and SNA applications via X.25

The same TNS parameters are used in both cases, i.e. for X.25 applications and for SNA applications via X.25.

TNS entries for the local application:

Global name	Type	Addr. format	T-selector
<i>Global Name</i>	TSEL	WAN3SBKA	{T A E X} string <i>string with max. 8 characters</i>

TNS entries for the remote application:

Global name	Type	Addr. format	Addr. component
<i>Global Name</i>	TA	WAN3SBKA	PVC pvc number or X.121 x.25-dte address (17 positions) {T A E X} string <i>string with max. 8 characters after T</i> <i>string with max. 32 characters after A, E and X</i> [WAN cc-no:line identifier]

Depending on which applications expand on the CMX, session components (SSEL) and presentation components (PSEL) may be specified. See the “CMX, Operation and Administration” User Guide [1] for details.

TNS parameters for TCP/IP via X.25

No TNS entries are required for standard TCP/IP applications (Sockets applications); however, TNS entries must be supplied for applications that use the ICMX or XTI program interfaces.

Detailed information on the TNS and on the TNS entries for program interfaces can be found in the “CMX, Operation and Administration” User Guide [1].

7.3 Configuration using the menu system

This section configuration using the menu system *CMXCUI*.

7.3.1 Configuring the local subnetwork interface

Menu	Choice
CMX Main Menu	CFs - CCP Configuration Files ...
Select Network Access	WAN
Configuration Files for WAN Network Access	a) Change CF: <input type="text" value="MARK"/> , <input type="text" value="ENTER"/> b) Create new CF: <input type="text" value="ENTER"/>
Operations on CFs	Create... or Edit
Create a New File	Name of configuration file: <i>name</i> Select CC type for the KOGS

When you SAVE the entries, a submenu to create the configuration file name for the selected CC type appears:

Edit configuration file [<i>name</i>] for <i>cc-type</i>	Select one of the displayed lines
Configuration for WAN Interface <i>no</i>	Local
Configure local network interface	Subnetwork: X.25 Subnet ID: X25-n Own DTE Address: Default transport protocol: NTP
X.25 Parameter for Interface <i>no</i>	Channel ranges for PVCs and SVCs: Attachment to X.25: Transmission speed: X.25 facilities arranged: <i>no</i>

If you have specified *X.25 facilities arranged: yes*, a further menu to create facilities will appear:

X.25 Facilities Arranged for Interface <i>no</i>	Enter special X.25 facilities
Configuration for WAN Interface <i>no</i>	Compile
Configuration for WAN Interface <i>no</i>	Exit

In order to ensure that your configuration entries take effect, you must assign the WAN network access and the generated configuration file to a Communications Controller and load the Communications Controller. See the section “Assigning and loading the configuration file” on page 66.

7.3.2 Defining routes

Menu

CMX Main Menu

Routes to Remote Subnetwork Interfaces

Operations on Routes to Remote Subnetwork Interfaces

Attributes of a Route

Choice

SNPAROUTES - Routes to Remote Subnetwork Interfaces

- a) Change route: ,
- b) Create new route:

Create... or Change...

Name: *name*

Type of remote subnet address:

X.25 or PVC

Subnet ID: must match the subnet ID in the CF

Specify remote subnetwork address: directly

For X.25 PVC: PVC number:

For X.25 SVC: X.25 DTE address:

Facilities:

If you have specified *Facilities: yes*, a further menu to create facilities will appear when you CONFIRM your entry:

Facilities to Route *name*

Admission:

Use PPP Subprofile:

Network Protocol ID:

Van-Jacobsen-Header-

Compression:

Use T70 Subprofile:

Menu**Choice**

Once you have saved, you will see a further window:

X25 Subnet Facilities to Route [name]	Packet Size outgoing: Packet Size incoming: Window Size / outgoing: Window Size / incoming: Throughput / outgoing: Throughput / incoming: Closed User Group: User group with outgoing access: bilateral Closed User Group: Reversed Charging: Transit Delay: Fast Select: RPOA Selection:
---------------------------------------	---

7.3.3 Entering partner systems

Menu

CMX Main Menu

Remote Hosts ...

Operations on Remote Systems

Remote NSAP Information (only for
TCP/IP)**Choice**

NSAPs - - Remote Hosts ...

a) Remote Hosts... Change:

,

b) Remote Hosts... Create

Create... or Change...

Name: *name*Network: *INTERNET*

Internet address:

Subnet address:

– Static routes:

Enter the name of the route(s) if
static routes are to be used

– Via Intermediate System:

Enter the network address
of the router if the partner
system is to be accessed via
a router.

7.3.4 Entering transport system applications

This section briefly describes the individual worksteps in the CMX menu system in the form of an overview. A detailed description can be found in the “CMX, Operation and Administration” User Guide [1].

Menu	Choice
CMX Main Menu	TSAs - Transport System Applications...
GLOBAL NAME of TS Application	a) Change global name: CHOICES, ENTER b) Create new global name: specify name part [1] - [5] (all name parts are optional)
Operations on TS Applications	Assign LOCAL NAME... CCP profile: WAN-X25 T-selector
Operations on TS Applications	Assign transport address... (entry for remote transport system application) CCP profile: WAN-X25 T-selector: Type of subnet address: X.25 DTE address: CC list:

7.4 Assignment of Connect Indications to Applications

X.25 applications access the X.25 software directly through the NTP Transport Service Provider. Since no transport protocol is used on X.25, there is the problem of assigning incoming connection requests to a local X.25 application. This assignment takes place by default in the Null Transport Provider, based on the user data provided when establishing the X.25 connection request.

The Null Transport Provider recognises two T-selector to which incoming connection request can be directed:

- If the user data begin with the hex string 0x01, this is an X.29 application and the data are delivered to the application that logged into CMX with the T-selector A'x29app01'.
- Otherwise, the connection request will be delivered to the X.25 application with the T-selector A'non2902'.

Incoming call dispatching table *ntpdisp*

The default number of recognised T-selectors limits can limit communications on systems with high X.25 traffic levels. In the Null Transport Provider, you have the option of using a mechanism which assigns incoming connection requests to freely configurable T-selectors as a function of the

- user data,
- the calling DTE address and
- the called DTE address.

This assignment of incoming connection requests to local X.25 applications is defined in the file, */opt/MAW/MAWcmx/lib/ntp/ntpdisp* and is not activated until this file is loaded by the Null Transport Provider.

This then replaces the default assignment. Each entry in this file contains four elements: the three attributes of the incoming connection request - user data, calling address, called address - and the T-selector of the local application. On reception of a connection request, the table is searched through from the beginning until the first entry is found whose attributes match those of the connection request. If no matching entry is found in the table, the connection request is refused.

To simplify the description of user data and addresses, you can describe these objects using simple regular expressions. The following meta-characters are permitted:

Meta-characters	Semantics
*	Wildcard notation: any sequence of characters, including spaces
+	Wildcard notation: any sequence of one or more characters
?	any character except but not a space
[Opens a character set display
]	Ends a character set display
^	Complement of a set display
-	Set range, e.g. for the characters from a to e: a-e

There is no escape symbol that cancels the meaning of this meta-character.

The syntactic structure of the incoming call dispatching table is specified in Backus-Naur notation.

```

<DispFile>          ::= {<DispFileEnt>}(0,2000)
                      /* A DispFile can contain up to 2000 entries.
                      A comment line is not interpreted as an entry.*/
<DispFileEnt>      ::= <Comment Line> | <DispFile-Entry>
<DispFile-Entry> ::= <User Data> <delimiter> <CallingAddr> <delimiter>
                      <CalledAddr> <delimiter> <TSe1> [<delimiter>] [<Comment>]
<LF>
<Comment Line>    ::= <Comment> <LF>

<User Data>       ::= <HexString>(0,16) | <ASCIIString>(0,16) | <Wildcard>
<CallingAddr>     ::= <X25 SVC>
<CalledAddr>      ::= <X25 SVC>
<TSe1>            ::= <ASCII TSe1> | <Hex TSe1>

<HexString>       ::= <HexId> <apo> [<Wildcard>] {<Hex Character>}(0,16)
                      [<Wildcard>] <apo>
<Hex Character>   ::= <Hex Digit> <Hex Digit>
<Hex Tse1>        ::= <HexId> <apo> {<Hex Character>}(1,10) <apo>

<ASCIIString>     ::= <ASCII Id> <apo> [<Wildcard>] {<ASCIICharacter>}(0,16)
                      [<Wildcard>] <apo>
<ASCII Tse1>      ::= <ASCII Id> <apo> {<ASCIICharacter>}(1,10) <apo>

<X25 SVC>         ::= <Svc Id> <apo> {<Digit>}(0,15) [<Wildcard>] <apo>

<Comment>         ::= <Comment Id> {<ASCIICharacter>}(0,n)
<Comment Id>      ::= '#'

<apo>              ::= ' ' /* single apostrophe 0x27 */
<delimiter>       ::= ',' | <tab> /* comma in ASCII: 0x2c

```

```

                                or tabulator          */
<LF> ::= 0x0a /* line feed */
<ASCII Id> ::= 'A'
<ASCIICharacter> ::= <AlphaNumChar> /* any printable ASCII character
                                except for the meta-characters, *,+,-
                                ,?,[,],^*/
                                | <AnyCharacter> | <CharacterSet>
<Hex Id> ::= 'X'
<Hex Digit> ::= '0' | '1' | '2' | '3' | '4' | '5' | '6' | '7' | '8' |
                '9' | 'a' | 'b' | 'c' | 'd' | 'e' | 'f'
<Svc Id> ::= 'S'
<Pvc Id> ::= 'P'
<Digit> ::= '0' | '1' | '2' | '3' | '4' | '5' | '6' | '7' | '8' |
<Wildcard> ::= '*' | /* 0 or more characters or digits*/
                '+*' /* at least one character or digit */
<tab> ::= {<tab id>}(0,n)
<tab id> ::= 0x09 | ' ' /* Tabulator(0x09) or space (0x20)
                */
<AnyCharacter> ::= '?'
<CharacterSet> ::= <OpenBracket> <CharacterSetDescr> <CloseBracket>
<OpenBracket> ::= '['
<CloseBracket> ::= ']'
<CharacterSetDescr> ::= [<Inverse Id>] {<AlphaNumChar>}(1,10) [<Range Id>]
                                {<AlphaNumChar>}(0,n)
                                /* The length of character set descriptions is
                                limited
                                to 10 characters. If a character set is described
                                using a range, the lower and
                                upper limits
                                must be given. Both must be of the same type:
                                Digit or Character */
<Range Id> ::= '-*'
<Inverse Id> ::= '^*' /* specifies the inverse (complementary) set */
<AlphaNumChar> ::= /* any digit or alphabetic character */
Notation:
{<non-term}>(n,m) means that the expression consists of at least n instances
and
at the most of m instances of the non-terminal.

```

Example

The following incoming call dispatching table contains six entries.

#	called user data	calling address	called address	local t-selector
X'a1'	S'*'	S'*'	A'app11'	
X'a1+	S'*'	S'*'	A'app12'	
A'?3'	S'*'	S'*'	A'app13'	
A'[[^] 12]4	S'*'	S'*'	A'app14'	
X'*'	S'123'	S'*'	A'app15'	
X'*'	S'*'	S'*'	A'nonx2902'	

Incoming connection requests with the user data 0x'a1' are delivered to the application that has logged in to CMX with the T-selector, A'app11'. Incoming connection requests that begin with the user data 0x'a1' and which are at least

2 Bytes long are sent to the application A'appl2'. The fifth entry in this table assigns the connection requests coming from the DTE address 123 to the application A'appl5', irrespective of the user data.

Note that the order of the entries determines the application to which an incoming connection request will be directed. If the attributes of a connection request match several entries then the first entry will always be selected. For example, a connection request from the DTE address 123 is sent to the application appl1 instead of the application appl5, if the user data are 0x'a1'. If, on the other hand, an entry only describes a subset of a preceding entry, this entry will never be selected.

Use a standard ASCII editor to prepare the incoming call dispatching table. On starting NTP an available dispatching table is transferred to the Null Transport Provider and thereby activated.

ntpicdt

The command *ntpicdt* is available to administer the incoming call dispatching function.

```
ntpicdt [-i]
          [-s]
          [-c [-f icd_file]]
          [-d]
          [-l [-f icd_file]]
```

- i** Selects the following information function: Shows whether an incoming call dispatching table is active and the number of entries in the active table.
- s** Selects the following information function: Shows details of the current attributes in each entry.
- c** Checks the syntax of an incoming call dispatching file. Lines with incorrect syntax are shown with the line number. The attributes in which an error is found are also shown.

We recommend that you only activate the incoming call dispatching file after the syntax analysis has been completed and has found no errors.

- d** Deactivates an incoming call dispatching file in the Null Transport Provider. The Null Transport Provider then uses the standard procedure for directing incoming connection request.

- I Activates an incoming call dispatching file by transferring it to the Null Transport Provider. Any file that is already active is deactivated and replaced by the new file.
You should note that any incoming connection requests which arrive during the brief activation time, will not be delivered.

7.5 Examples

This section contains examples to illustrate the configuration of network connections via an X.25 subnetwork. This includes X.25 applications, SNA applications, and TCP/IP via X.25 with appropriate X.25 facilities.

7.5.1 X.25 applications and SNA applications via an X.25 SVC

This configuration applies to applications such as TRANSIT, EMX28, and TSX29.

TNS entries

```
W3_2\  
TSEL WAN3SBKA A*nonx2902' ; TRANSIT  
W3_4\  
TSEL WAN3SBKA A*x29app01' : EMX28, TSX29  
W3_1\  
TA WAN3SBKA X.121 4590255
```

FSS entries

```
FACIL ( name= Fac54 x25-cug=0001)  
SNPAROUTES ( name=CSSNY002 subnet=X25-32 dte-addr=4590255  
facil=Fac54 )
```

KOGS source file

```
XSYSP  
XSNID SUBNID = X25-32,  
ADRTYP = X25_ADR  
XLTNG PROFIL = NTP,  
DTEADR = 4590054,  
SKANALN = 1-20,  
UEWEG = X25/TYP58,  
UEGSW = 64000,  
WDHZAEL = 3,  
X21DEF = DBP,  
LPUFADR = 2  
XEND
```

7.5.2 TCP/IP via an X.25 SVC

The configuration is defined in the WAN-NX25 profile.

TNS entries are required only for CMX applications (e.g. *openFT*). The FSS and KOGS entries are sufficient for standard TCP/IP applications such as telnet, ftp, and rlogin.

FSS entries

```
FACIL ( name=Fac54 admit=BOTH_IN_AND_OUT compress=TCP/IP )
SNPAROUTES ( name=IP02 subnet=X25-32 dte-addr=4590255
              name=Fac54 )
NSAP ( name=IP2 internet-addr=80.0.0.3 snpa-list=IP02 )
```

KOGS source file

```
XSYSP
XSNID  SUBNID = X25-32,
        ADRTYP = X25_ADR
XLTNG  PROFIL = PPP,
        DTEADR = 4590054,
        SKANALN = 1-20,
        UEWEG = X25/TYP8,
        VUEZEIT = 24,
        UEGSW = 64000,
        WDHZAEL = 3,
        X21DEF = DBP,
        LPUFADR = 2
XEND
```

Interface configuration

You must configure an interface with the command *csr create* (see the manual “CMX, TCP/IP via WAN/ISDN“ manual [4]).

Example: The Internet address of the interface clwip0 is 88.0.0.2:

```
csr create if name=clwip0 ipaddr=80.0.0.2
```

7.5.3 X.25 partner facilities in the FSS

Special features

X.25 facilities can be configured in the FSS for all remote X.25 network partners independently of the used transport or network profile. The FACIL object containing the facilities is referenced in the SNPAROUTES object by means of the *facil* parameter.

FSS entries

```
FACIL ( name=x25fac1
        x25-packet-size=1024/1024 x25-window-size=7/7
        x25-cug=05 x25-revch=REQUEST_ONLY
        x25-fast-select=NO_RESTRICTION )
SNPAROUTES ( name=IP3 subnet=X25-22 dte-addr=1600000
              facil=x25fac1 )
```

7.5.3.1 Special case: Fast Select

The “Fast Select” facility must be explicitly ordered from the network provider and be configured accordingly in the facilities for the port in the KOGS source file.

Principle in the KOGS source file:

```
XFACI    NAME = LTG1,
         AKFACI = FASTSEL
XLTNG    ...
         FACIL = LTG1,
         ...
```

FSS entries

In addition, an entry must be made in the FSB for each X.25 partner with whom the Fast Select facility has been agreed.

```
FACIL ( name=x25fac5 x25-fast-select=NO_RESTRICTION )
SNPAROUTES ( name=IP4 subnet=X25-22 type=X25
              dte-addr=1600000 facil=x25fac5 )
```

7.5.3.2 Special case: Reversed Charging

Only the value in the FSB is evaluated for an outgoing call.

```
FACIL ( name=x25fac5 x25-revch=REQUEST_ONLY )  
SNPAROUTES ( name=IP4 subnet=X25-22 dte-addr=1600000  
             facil=x25fac5 )
```

If “Reversed Charging” has been configured in the KOGS source (AKFACI = REVCH), charges are accepted for all incoming calls that request it. Note that the entries in the FSS are not relevant for incoming calls in this case!

If “No Reversed Charging” has been configured in the KOGS source (AKFACI = NOREVCH) and an incoming call requests a reversal of charges, the FSB is consulted.

7.5.4 Selecting an alternative network port

Two X.25 ports (1930000, 1950000) are available on the active side, and two X.25 ports (1450000, 1910000) are likewise available on the passive side.

Configuration on the active side

TNS entries

```
X25200301\  
    TA    WAN3SBKA X.121 1930000
```

FSS entries

```
SNPAROUTES ( name=x25200301 subnet=X25-11 dte-addr=1930000 )
```

KOGS source file

```
XSYSP  
XSNID    SUBNID = X25-11,  
         ADRTYP = X25_ADR  
XLTNG    LPUFADR = 1,  
         DTEADR = 1450000,  
         UEGSW = 64000,  
         VUEZEIT = 24,  
         X21DEF = DBP,  
         SKANALN = 1-64,  
         UEWEG = X25/TYP8  
XLTNG    LPUFADR = 2,  
         DTEADR = 1910000,  
         UEGSW = 64000,  
         VUEZEIT = 24,  
         X21DEF = DBP,  
         SKANALN = 1-32,  
         UEWEG = X25/TYP8  
XEND
```

8 The WAN-SDLC profile

8.1 Profile description

The WAN-SDLC profile supports connections to SNA networks with the SDLC protocol.

In combination with the product TRANSIT-SERVER, the WAN-SDLC profile supports the full scope of the SNA XID exchange, and thus APPN via SDLC ports.

You will find more detailed information on connecting UNIX systems to SNA networks and a description of SNA concepts in the “Interfacing to SNA Networks” [5] core manual.

The following figure shows how a system is connected to a circuit switching network when using the WAN-SDLC profile:

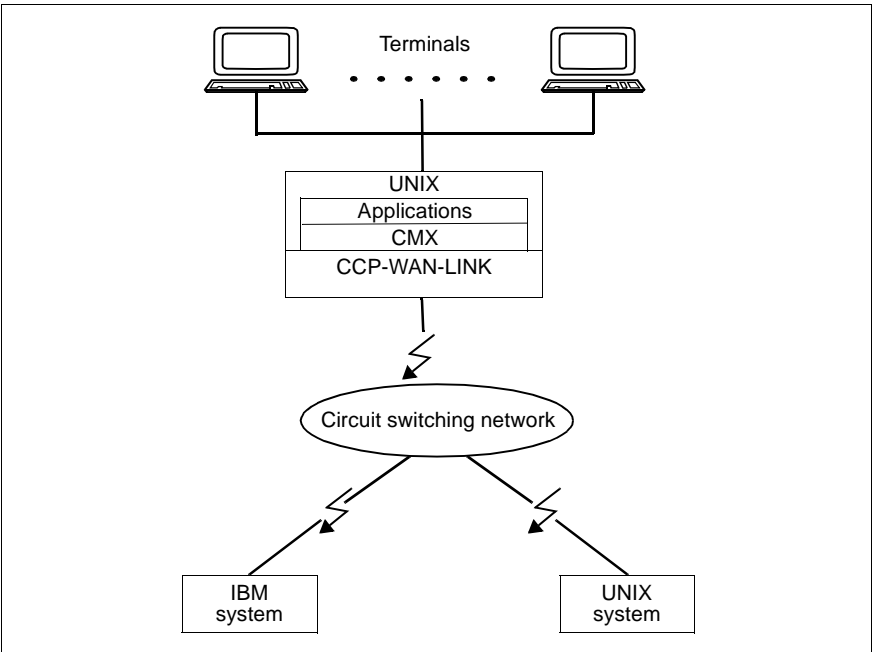

Figure 21: Connection of a UNIX system using the WAN-SDLC profile

Transport system protocols

The WAN-SDLC profile uses the null transport provider. The transport protocol for SNA is provided by the TRANSIT-SERVER product. The following protocols are assigned to the WAN-SDLC profile at OSI layers 1 to 4:

Layer	Function	Protocols
4	Transport	-
3	Network	–
2	Data Link	SDLC
1	Physical	X.21/V.24/V.25bis

Table 37: Transport system protocols for the WAN-SDLC profile

Connection options

The WAN-SDLC profile offers the following connection options:

SNA type	Con- nection	V.24 dedicated line	V.24 dial- up line (V.25bis)	X.21 dedicated line	X.21 dial-up line
2.0 Secondary	PtP ¹	yes	yes	yes	no
2.0 Primary	PtP	no	no	no	no
2.0 Secondary	MP ²	yes	no	yes	no
2.0 Primary	MP	no	no	no	no
2.1 Secondary	PtP	yes	yes	yes	no
2.1 Primary	PtP	yes	yes	yes	no
2.1 Negotiable	PtP	yes	yes	yes	no

Table 38: Connection options for the WAN-SDLC profile

It is possible to operate up to 4 SDLC lines on a board; however, SDLC lines cannot be bundled or grouped. An SDLC line is dedicated per configuration, i.e. to the WAN-SDLC profile, and cannot be simultaneously used for other CCP profiles (e.g. for WAN-NEA or WAN-CONS).

¹ PtP: point-to-point

² MP: multipoint

The SDLC ports are represented by unique subnet IDs, where every subnet ID that is configured for the various SDLC ports in a UNIX system (including those across CCs) must be different. This means that the subnet IDs must also be uniquely assigned to a port.

The maximum supported transmission rates are: 19,2 Kbit/s for V.24 interfaces and 2048 Kbit/s for X.21 interfaces.

8.2 KOGS, FSS and TNS parameters

The following sections contain lists that show which of the KOGS macros described in the chapter „Configuration with KOGS macros“ on page 223 can be used for the WAN-SDLC profile.

No FSS entries are required to configure remote partners. These partner details must be configured in the TRANSIT-SERVER [5] product.

8.2.1 KOGS parameters

The meanings of the individual macros and operands listed below can be found in the chapter „Configuration with KOGS macros“ on page 223.

Macro	Operands	Operand values
XEND		
XLTNG	[DUETYP]	<u>MODEM</u> , DIREKT
	LPUFADR	1...4
	[MAXIFL]	<u>256</u> ...1033
	MODE	IBM
	[MODTAKT]	<u>NEIN</u> (NO) (for DUETYP=DIREKT) <u>JA</u> (YES) (otherwise)
	[NRZI]	<u>JA</u> (YES) , NEIN (NO)
	[POLLPAU]	0, 100... <u>500</u> ...3600
	PROFIL	SDLC
	[PRTIMER]	3000...60000 for X.21 Default depends on UEGSW
	[PRTIM2]	100... <u>500</u> ...3000
	[PRTIM3]	0... <u>65000</u> ...6000000
	[RCB]	<u>0</u> ...65535

Table 39: KOGS parameters for the WAN-SDLC profile

Macro	Operands	Operand values
	[RUF]	AUTO AUTO/ANK, AUTO/ABG DIREKT, DIREKT/ABG MANUELL, MANUEL/ABG
	[RUFNUM]	<i>call number</i> up to 24 characters
	[RUFPAUS]	<u>6</u> ...120
	[RUFWDH]	0... <u>3</u> ...7
	[TPAUSE]	<u>NEIN</u> (NO), JA (YES)
	[UEGSW]	1200... <u>9600</u> ...19200 for V24DEF (increases to 64000 for DUETYP=V35/36-ADAPTER) 1200... <u>9600</u> ...19200, 48000, 64000, 128000, 256000, 512000, 1024000, 204800 for X21DEF
	[UEKONF]	<u>PZP</u> , MP
	[UEUNB]	<u>PRI/DX</u> , PRI/HX, SEC/HX, SEC/DX
	UEWEG	FE-STAND/2DR, FE-STAND/4DR FE-WAHL/2DR, FE-WAHL/4DR
	[V24DEF]	STD
	[WDHZAHL]	0... <u>3</u> ...255
	[X21DEF]	<u>DBP</u>
XSNID	ADRTYP	HDLCPP for HDLC point-to-point connections PT_ADR or PT-ADR for telephone network
	SUBNID	PP-i, i=1...32 for dedicated lines PT-i, i=1...32 for telephone network
XSYSP		

Table 39: KOGS parameters for the WAN-SDLC profile

8.2.2 FSS parameters

No FSS parameters are required. You must configure the partners in the TRANSIT-SERVER [5] product.

8.2.3 TNS parameters

A unique assignment exists between the station name of an application and the configured SDLC ports. This assignment must be unique on a system-wide basis (i.e. even across CCs).

Detailed information on the TNS and on TNS entries for the program interface can be found in the “CMX, Operation and Administration” User Guide [1].

A transport system application that uses the CCP profile WAN-SDLC must use (local) station names in the format “\$PP-i” or “\$PT-i” at registration.

TNS entries for the local application:

Global name	Type	Addr. format	T-selector
-------------	------	--------------	------------

<i>Global name</i>	TSEL	SDLC SBKA	T \$PP-i or T \$PP-j or T \$PT-k <i>i</i> =1...32 (X.21 dedicated PzP/MP) <i>j</i> =1...32 (V.24 dedicated PzP/MP) <i>k</i> =1...32 (V.24 dial-up /V.25bis)
--------------------	------	-----------	--

In the case of dedicated lines, a (remote) “dummy call number” must be specified in the transport address. The “dummy call numbers” in a system must be unique.

TNS entries for the remote application:

Global name	Type	Addr. format	Addr. component
-------------	------	--------------	-----------------

<i>Global name</i>	TA	SDLC SBKA	remote_call number (“dummy call number” for dedicated line) or E.163 remote_callnumber (for dial-up lines) [WAN cc-no:line identifier]
--------------------	----	-----------	--

8.3 Configuration using the menu system

This section describes configuration using the menu system *CMXCUI*.

8.3.1 Configuring the local subnetwork interface

Menu	Choice
CMX Network Access menu	CFs - CCP Configuration Files...
Select Network Access	WAN
Configuration Files for WAN Network Access	a) Change CF: MARK , ENTER b) Create new CF: ENTER
Operations on CFs	Create... or Edit
Create a New File	Name of configuration file: <i>name</i> Select CC type for KOGS

When you **SAVE** the entries, a submenu to create the configuration file name for the selected CC type appears:

Edit configuration file [<i>name</i>] for <i>cc-type</i>	Select one of the displayed lines
Configuration for WAN Interface <i>no</i>	Local
Configure local network interface	Subnetwork: (X21 dial-up line, dedicated line, phone) Subnet ID: [Own telephone number] Line number Default transport protocol: SNA

You must fill in the menu that follows (Parameter for Interface *no* to *network*).

Configuration for WAN Interface <i>no</i>	Compile
Configuration for WAN Interface <i>no</i>	Exit

In order to ensure that your configuration entries take effect, you must assign the WAN network access and the generated configuration file to a Communications Controller and load the Communications Controller. See the section „Assigning and loading the configuration file“ on page 66.

8.3.2 Entering transport system applications

This section briefly describes the individual worksteps in the CMX menu system in the form of an overview. A detailed description can be found in the “CMX, Operation and Administration” User Guide [1].

Menu	Choice
CMX Main Menu	TSAs - Transport System Applications...
GLOBAL NAME of TS Application	a) Change global name: [CHOICES], [ENTER] b) Create new global name: specify name part [1] - [5] all name parts are optional)
Operations on TS Applications	Assign LOCAL NAME... CCP profile: WAN-SDLC T-selector:
Operations on TS Applications	Assign transport address... (entry for remote transport system application) CCP profile: WAN-SDLC Call number: CC list:

8.4 Examples

8.4.1 WAN-SDLC primary dedicated line

TNS entries

```
sde_test_loc1
    TSEL SDLCSBKA T'$PP-1' # Station name for
                          subnet ID PP-1
sde_test_rem1
    TA      SDLCSBKA 999999 # The dummy call number
                          is 999999
```

KOGS source file

X.21 dedicated line, point-to-point:

```
XSYSP
XSNID  SUBNID = PP-1,
        ADRTYP = HDLCPP
XLTNG  LPUFADR = 1,
        UEGSW = 64000,
        UEWEG = FE-STAND/4DR,
        X21DEF = DBP,
        MODE = IBM,
        UEUNB = PRI/DX,
        WDHZAE = 3,
        PRTIM2 = 3000,
        PROFIL=SDLC
XEND
```

8.4.2 WAN-SDLC primary dial-up line

TNS entries

```
sde_test_loc2
    TSEL SDLCSBKA T'$PT-1' # Station name for
                               subnet ID PT-1
sde_test_rem2
    TA    SDLCSBKA E.163 6364712
```

KOGS source file

V.24 dial-up line, point-to-point:

```
XSNID    SUBNID  = PT-1,
          ADRTYP  = PT_ADR
XLTNG    LPUFADR = 2,
          PROFIL  = SDLC,
          MODE    = IBM,
          DUETYP  = MODEM,
          NRZI    = JA,
          PRTIM2  = 500,
          WDHZAEL = 3,
          UEGSW   = 9600,
          TPAUSE  = NEIN,
          V24DEF  = STD,
          UEPROZ  = HDLC/UNB,
          UEUNB   = SEC/DX,
          UEKONF  = PZP,
          RUFNUM  = 6364711,
          RUF     = AUTO,
          RUFPAUS = 6,
          RUFWDH  = 3,
          UEWEG   = FE-WAHL/4DR
XEND
```

8.4.3 Direct link

The arrows point to references in the individual files.

TNS entries

```
sde_test_loc1 ←
    TSEL    SDLCBKA T'$PP-1'
```

```
sde_test_loc2 ←
    TA      SDLCBKA 999999 WAN 1:2
```

KOGS source file for TRANSIT

```
XLINK SDLC_E,  ACT = AUTO,
              TYP = E-SDLC, ←
              XID = 12355555,
              NAME-PART[5] = sde_test_loc1
```

```
XPU  SDE21NEG, TYP = PEER, ←
      CONNECT = AUTO, ←
      DISCNT = AUTO,
      LINK = SDLC_E, ←
      ROLE = PRI,
      LINKADR = C1,
      XID = 32199999,
      NAME-PART[5] = sde_test_loc2
```

```
XLU  tsdei1,  TYP = 6, ←
      SESS-CTR = IND,
      SESS-LMT = 6,
      NETNAME = TSDEI1,
      PAIR = tsdei2 MODDIS89
```

```
XRLU tsdei2,  NETNAME = TSDEI2,
      PU = SDE21NEG
```

```
XMODE MODDIS89, SRU-MAX = 89, ←
                RRU-MAX = 89,
                SESS-MAX = 10,
                SESS-AUTO = 0,
                SESS-WIN = 1,
                SESS-LOS = 1
```

```
XEND
```

KOGS source file

```
XSYSP
XSNID   SUBNID = PP-1,
        ADRTYP = HDLCP
XLTNG   LPUFADR = 2,
        UEGSW = 2048000,
        UEWEG = FE-STAND/4DR,
        X21DEF = DBP,
        MODE = IBM,
        UEUNB = SEC/DX,
        WDHZAEL = 3,
        PRTIM2 = 3000,
        UEPROZ = HDLC/UNB,
        PROFIL = SDLC
XEND
```

9 The WAN-FR profile

9.1 Profile description

The WAN-FR profile allows you to use your UNIX system both as an end system and as a router.

To begin with, you can integrate your system as an **end system** in a TRANDATA network or use it to communicate with non-SNI systems. Note that your communication partners may be linked to your UNIX system in different ways, i.e.:

- directly via a dedicated line
- via a public or private frame relay network, or
- via a frame relay network, a router and a remote LAN.

You may also use your UNIX system as a **frame relay router** and thus link several LANs using frame relay.

Since you can run TCP/IP via a frame relay connection, you can effectively exchange data with a wide variety of partner systems. Seen in this context, the WAN-FR profile can be essentially compared with exchanging data via an X.25 interface.

The following figure shows how a system is connected as an **end system** when using the WAN-FR profile:

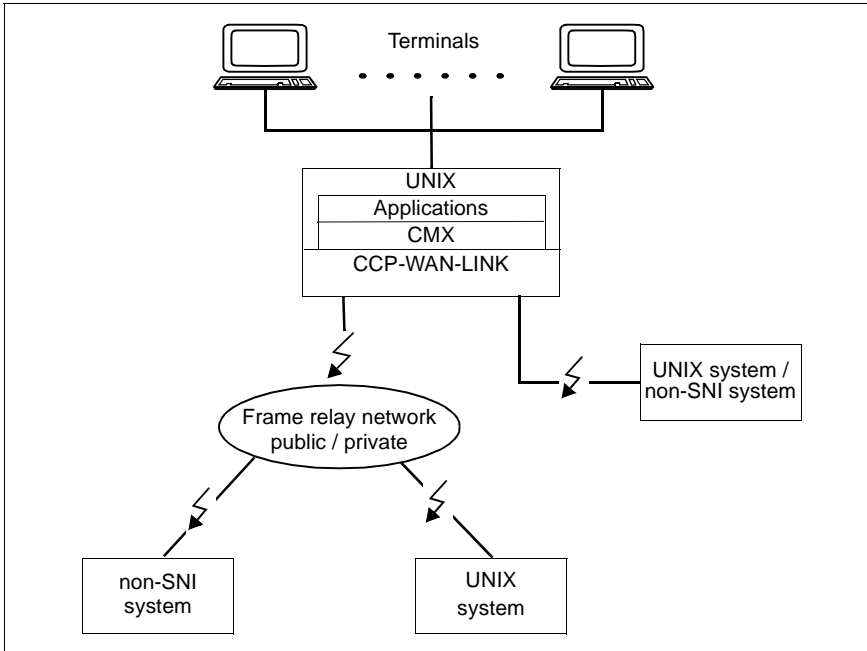

Figure 22: Connection of a UNIX system as an end system when using the WAN-FR profile

The following figure shows how a system is connected as a **frame relay router** when using the WAN-FR profile:

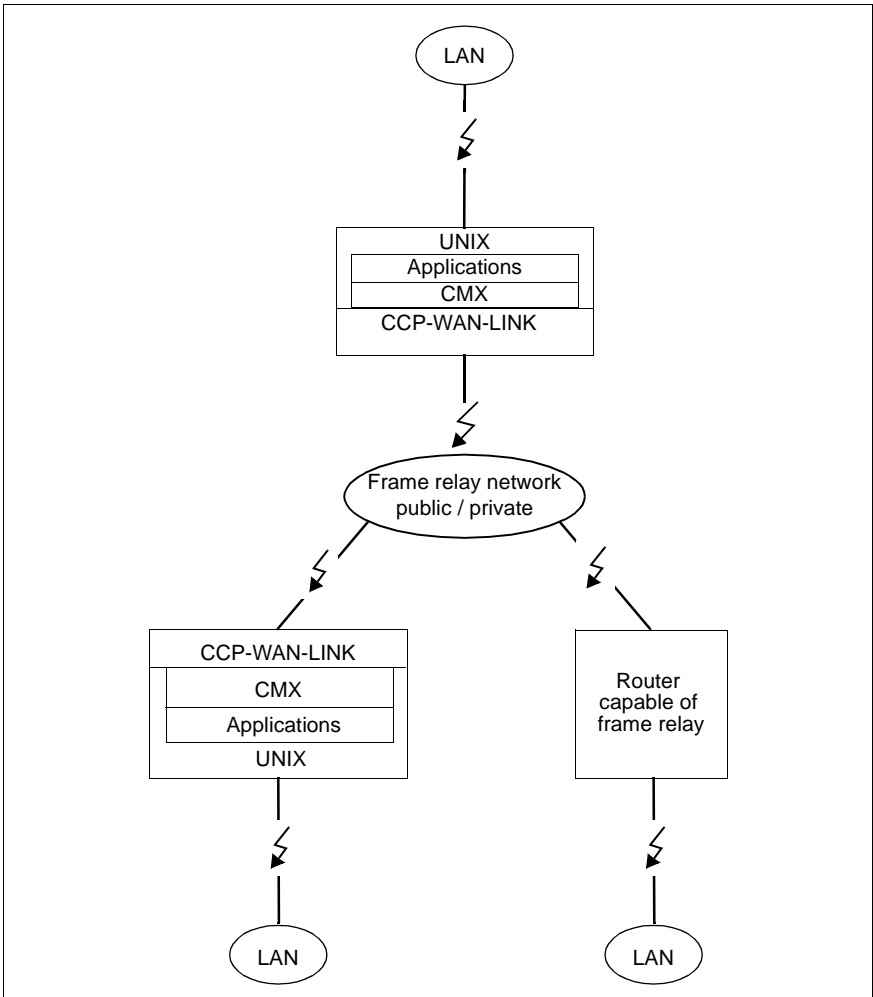

Figure 23: Connection of a UNIX system as a frame relay router using the WAN-FR profile

Transport system protocols

The profile consists of the WAN network access with one or more frame relay interfaces and the transport service provider NTP. The following protocols are assigned to the WAN-FR profile at OSI layers 1 to 4:

Layer	Function	Protocols
4 / 3	Transport/ Routing	TCP/IP
2	Relaying*	Frame relay in accordance with CCITT Q.922, Annex A
1	Physical	X.21 (up to 2 Mbit/s)

Table 40: Protokolle des Transportsystems für das Profil WAN-FR

* Provides virtual connections. Data backup is not performed.

9.2 KOGS, FSS and TNS parameters

The following sections contain lists that show which of the specified parameters and value ranges for the KOGS macros (presented in the chapter “Configuration with KOGS macros” on page 223) and for the FSS and TNS databases (described in the “CMX, Operation and Administration” User Guide [1]) can be used for the WAN-FR profile.

9.2.1 KOGS parameters

The meanings of the individual macros and operands listed below can be found in the chapter “Configuration with KOGS macros” on page 223.

Macro	Operands	Operand values
XEND		
XLTNG	[DUETYP]	<u>MODEM</u> , V35/V36-Adapter
	[MODTAKT]	<u>JA</u> (YES) NEIN (NO)
	[NRZI]	<u>NEIN</u> (NO) JA (YES)
	UEPROZ	FR
	UEWEG	FE-STAND/4DR
	LPUFADR	1...4
	UEGSW	1200... <u>64000</u> ...2048000
	X21DEF or V24DEF	DBP STD
	OPTIONS	none or option 9 (default is “none“)
	FRFSCC	only for option 9: 1... <u>6</u> ...255 (integer between 1 and 255, default value is 6)
	FRERTHR	only for option 9: 1... <u>2</u> ...10 Condition:FRERTHR<=FREVCNT

Table 41: KOGS parameters for the WAN-FR profile

Macro	Operands	Operand values
	FREVCNT	only for option 9: 1... <u>4</u> ...10 Condition:FRERTHR<=FREVCNT
	PRTIMER	only for option 9: 5000, <u>10000</u> , 15000, 20000, 25000, 30000
XSNID	ADRTYP	FR_PVC or FR-PVC for frame relay PVCs
	SUBNID	FR-1...FR-128 for frame relay
XSYSP		

Table 41: KOGS parameters for the WAN-FR profile

9.2.2 FSS parameters

For more information on the individual object classes and attributes, see chapter “FSS configuration” on page 269.

Object class FACIL: Define facilities

Recommendations for the values of FACIL attributes:

- The transmission rate of a frame relay subnetwork port (UEGSW parameter of the KOGS macro XLTNG) should be based on the total Committed Information Rates (*fr-cir* attribute) for all PVCs of the port.

Selecting a transmission rate that is too high will result in unnecessary charges.

On the other hand, if the selected transmission rate is too low, it will not be possible to fully utilize all PVCs simultaneously at the port.

- The appropriate value for the *fr-max-transit-delay* attribute will depend on the size and complexity of the frame relay network:

one-tenth of a second may be a suitable value for a PVC via a dedicated line (not a frame relay network!), whereas five-tenths of a second may be more appropriate for a PVC via a network with a frame relay switch.

Attribute	Format	Meaning
name	1-15 characters comprising letters, digits, and the special characters <code>_</code> and <code>#</code> . A distinction is made between uppercase and lowercase. The first character must not be a digit or an underscore <code>'_'</code> .	Name of the FACIL object
facil	See <i>name</i>	Name of a further FACIL object that is referenced
npid	INTERNET	Network protocol ID. Only possible value: INTERNET Does not need to be specified
fr-encaps	YES <u>NO</u>	Protocol encapsulation in accordance with RFC 1490
fr-cir	0... <u>64</u> ...2048 Kbit/s $\text{fr-cir} \leq \text{value of the UEGSW parameter (KOGS macro XLTNG)}$	Committed Information Rate
fr-cbs	0... <u>64</u> ...2048 Kbits $\text{fr-cbs} = n * \text{fr-cir}$ $\text{fr-cbs} + \text{fr-ebc} \leq 2048 \text{ Kbits}$	Committed Burst Size
fr-ebc	<u>0</u> ...2048 Kbits $\text{fr-ebc} + \text{fr-cbs} \leq 2048 \text{ Kbits}$	Excess Burst Size
fr-prio	1 <u>2</u> 3 (1 = highest priority)	Priority
fr-max-transit-delay	<u>1</u> ...65535 tenths of a second	Maximum transit delay

Table 42: Attributes of the FACIL object class

Object class LOCNSAP: Local host

No separate LOCNSAP entries are required when configuring The WAN-FR profile.

Object class NSAP: Remote network service access point

The following attributes are relevant when configuring TCP/IP using frame relay:

Attribute	Format	Meaning
name	1-32 printable and visible characters	Name of the NSAP object
internet-addr	<i>no.no.no.no</i> <i>no</i> : decimal number (0..255)	32-bit Internet NSAP address
net*	INTERNET	Network used by the local system to reach the NSAP
access*	DIRECT	Access to the SNPA address via which the NSAP can be reached
snpa-list	<i>snpa+snpa+...+snpa</i> with max. 20 list elements. <i>snpa</i> : <i>name</i> <i>name/weight</i> <i>name</i> : see <i>name</i> under SNPAROUTES <i>weight</i> : digit from 1-20.	List of alternative SNPAROUTES objects that can be used to reach this NSAP. The priority can be specified with a value for <i>weight</i> (20 is the highest priority).

Table 43: Attributes of the NSAP object class

* The “net” and “access” attributes need not be specified in the configuration file or in the *create* command (*fssadm create NSAP...*), since they are implicitly obtained from other attributes.

Additional filter criteria that are only permitted for *fssadm get*:

Attribute	Format	Meaning
type	FR-PVC	Subnet address type
subnet	FR- <i>n</i> <i>n</i> = 1...128	Subnet ID

Table 44: Filter attributes of the NSAP object class

Object class REMSNPA: Remote subnetwork ports

Attribute	Format	Meaning
name	1-15 characters comprising letters, digits, and the special characters <code>_</code> and <code>#</code> . A distinction is made between uppercase and lowercase. The first character must not be a digit or an underscore <code>'_'</code> .	Name of the REMSNPA object
facil	See <i>name</i>	Name of a FACIL object
fr-pvc	<i>cc-no/line-no/pvc-no</i> Value range for <i>cc-no</i> : 1 - 256 Value range for <i>line-no</i> : 1 - 4 Value range for <i>pvc-no</i> : 16 - 1007	CC number, Line number; corresponds to the decimal value of the KOGS parameter LPUFADR. Number of the frame relay PVC
type	FR-PVC	Subnet address type

Table 45: Attributes of the REMSNPA object class

Object class SNPAROUTES: Routes**Association between subnet address type and subnet ID**

Depending on the subnet address type, you can assign the subnet ID as follows:

Subnet addr. type	Subnet ID
FR-PVC	FR-x

Table 46: Assignment of subnet ID to subnet address type

Attribute	Format	Meaning
name	1-15 characters comprising letters, digits, and the special characters _ and #. A distinction is made between uppercase and lowercase. The first character must not be a digit or an underscore '_'.	Name of the SNPAROUTES object
rem-snpa	See <i>name</i>	Name of a REMSNPA object that represents the remote subnetwork address
subnet	FR- <i>n</i> <i>n</i> = 1...128	Subnet ID

Table 47: Attributes of the SNPAROUTES object class

9.2.3 TNS parameters

TNS entries are required only for CMX applications (e.g. openFT). The FSS and KOGS entries are sufficient for standard TCP/IP applications such as telnet, ftp, and rlogin.

9.3 Configuration using the menu system

This section describes configuration using the menu system *CMXCUI*.

9.3.1 Configuring the local subnetwork interface

Menu	Choice
CMX Main Menu	CFs - CCP Configuration Files...
Select Network Access	WAN
Configuration Files for WAN Network Access	a) Change CF: MARK , ENTER b) Create new CF: ENTER
Operations on CFs	Create... or Edit
Create a New File	Name of configuration file: <i>name</i> Select CC type for the KOGS

When you **SAVE** the entries, a submenu to create the configuration file *name* for the selected CC type appears:

Edit configuration file [<i>name</i>] for <i>cc-type</i>	Select one of the displayed lines
Configuration for WAN Interface <i>no</i>	Local
Configure local network interface	Subnetwork: Frame Relay Subnet ID: FR- <i>n</i> Default transport protocol: NTP
Parameter for Interface <i>no</i> to <i>network</i>	Modify line parameters or confirm the default values, e.g. for transmission speed, NRZI, HDLC protocol variant, etc.
Configuration for WAN Interface <i>no</i>	Compile
Configuration for WAN Interface <i>no</i>	Exit

In order to ensure that your configuration entries take effect, you must assign the WAN network access and the generated configuration file to a Communications Controller and load the Communications Controller. See the section “Assigning and loading the configuration file” on page 66.

9.3.2 Defining routes

Menu	Choice
CMX Main Menu	SNPAROUTES - Routes to Remote Subnetwork Interfaces
Routes to Remote Subnetwork Interfaces	a) Change route: <input type="text" value="MARK"/> , <input type="text" value="ENTER"/> b) Create new route: <input type="text" value="ENTER"/>
Operations on Routes to Remote Subnetwork Interfaces	Create... or Change...
Attributes of a Route	Name: <i>name</i> Type of subnet address: <i>FR-PVC</i> Subnet ID: (must match the subnet ID in the CF) Specify remote subnetwork address: <i>cc-nolline-nolpvc-no</i>

9.3.3 Entering partner systems

Menu	Choice
CMX Main Menu	NSAPs - Remote Hosts ...
Remote Hosts...	a) Remote Hosts ... Change: <input type="text" value="MARK"/> , <input type="text" value="ENTER"/> b) Remote Hosts ... Create: <input type="text" value="ENTER"/>
Operations on Remote Systems	Create... or Change...
Remote NSAP Information	Name: <i>name</i> Network: INTERNET Internet Address: Subnet Address: Static routes: The SNPA address for this partner system is specified directly.

9.4 Examples

9.4.1 TCP/IP via frame relay

The following configuration describes a local frame relay network access on the Communications Controller W1, line 1. The PVC number, which must be agreed with the network provider, is 20.

FSS entries

The facilities are optional:

```
FACIL ( name=Fac02 npid=INTERNET fr-encaps=NO fr-prio=1
        fr-cbs=1024 fr-cir=1024 fr-eps=1024
        fr-max-transit-delay=5 )
```

You specify the PVC number in an SNPAROUTES object (attribute *fr-pvc*):

```
SNPAROUTES ( name=FRSNY002 subnet=FR-1 fr-pvc=1/1/20 ; CC: W1
              ; Line number: 1
              : PVC number: 20
              facil=Fac02 )
```

The following NSAP identifies the remote partner system with IP address 88.0.0.2:

```
NSAP ( name=FRNSY002 internet-addr=88.0.0.2 net=INTERNET
       access=DIRECT snpa-list=FRSNY002 )
```

KOGS source file

The main differences with respect to other profiles are:

```
XSNID    SUBNID = FR-..
XLTNG    UEPROZ = FR
```

Otherwise, the configuration is the same as for a dedicated line:

```
XSYSPP
XSNID    SUBNID = FR-1,
          ADRTYP = FR-PVC
XLTNG    UEPROZ = FR,
          UEGSW = 2048000,
          UEWEG = FE-STAND/4DR,
          NRZI = NEIN,
          X21DEF = DBP,
          LPUFADR = 1
XEND
```

Interface configuration

An interface must be created by using the command *csr create*.

The interface `clwip0` provides access to the local frame relay port with subnet ID `FR-1`. The IP address of the interface is `88.0.0.1`.

```
csr create if name=clwip0 ipaddr=88.0.0.1 snid-list=FR-1
```

10 Two-step dialing to and from an X.25 network via a phone network to X.32

10.1 Profile description

CCP-WAN supports two-step dialing to and from X.25 networks via any (analog) telephone network to X.32 (also known as X.32 dialing). This allows you to connect a UNIX system as a packet-oriented DTE to an X.25 network via any standard telephone network. Note that dialing via circuit switching digital data networks such as Datex-L is not supported in X.25 networks.

X.32 dialing can be implemented in the WAN-NX25, WAN-CONS with X.25, and WAN-X25 profiles.

The following figure shows how a UNIX system is connected to a packet switching network via a telephone network:

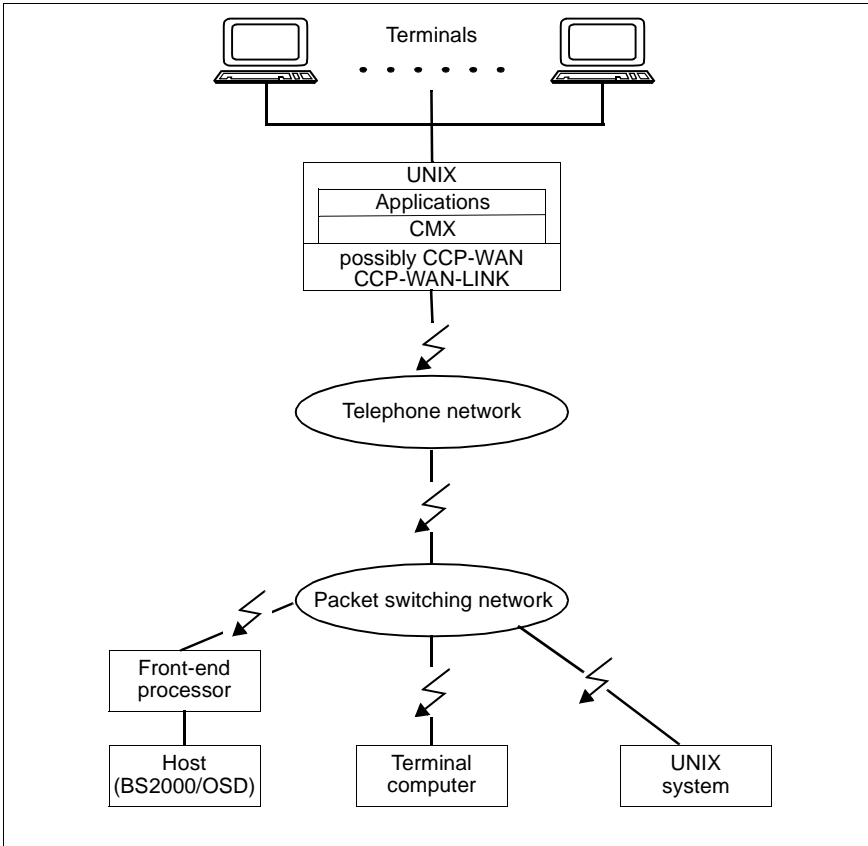

Figure 24: Connection of a UNIX system for X.32 dialing

The process of setting up a connection for X.32 dialing is explained in the section “How X.32 dialing works” on page 48.

10.2 KOGS, FSS and TNS parameters

The following sections contain lists that show which of the specified parameters and value ranges for the KOGS macros (presented in the chapter “Configuration with KOGS macros” on page 223) and for the FSS and TNS databases (described in the “CMX, Operation and Administration” User Guide [1]) can be used for X.32.

10.2.1 KOGS parameters

The port configured for X.32 dialing is initially a port to a telephone network, so only the parameters for the phone connection are relevant in the KOGS macro XLTNG. The X.25 parameters must be specified in the KOGS macro XZSTW.

The meanings of the individual macros and operands listed below can be found in the chapter “Configuration with KOGS macros” on page 223.

Macro	Operands	Operand values
XEND		
XFACI	[AKFACI]	<u>NOREVCH</u> REVCH FASTSEL <i>list</i>
	[DTEADCA]	JA (YES) TOANPI <i>list</i>
	FACIL	<i>name</i> max. 7 characters
	[PAKLE]	16...2048 (power of 2)
	[PAKLS]	16...2048 (power of 2)
	[PAKNUM]	<u>MOD8</u> MOD128
	[R20]	1... <u>10</u> ...128
	[R22]	1... <u>10</u> ...128

Table 48: KOGS parameters for X.32

Macro	Operands	Operand values
	[R23]	1... <u>2</u> ...128
	[T20]	1... <u>10</u> ...2048
	[T21]	1... <u>200</u> ...2048
	[T22]	1... <u>10</u> ...2048
	[T23]	1... <u>10</u> ...2048
	[T24]	<u>0</u> ...2048
	[T25]	0... <u>180</u> ...2048
	[WINDE]	PAKNUM = MOD8: 1... <u>2</u> ...7 PAKNUM = MOD128: 1... <u>2</u> ...127
	[WINDS]	PAKNUM = MOD8: 1... <u>2</u> ...7 PAKNUM = MOD128: 1... <u>2</u> ...127
XLTNG	[DUETYP]	<u>MODEM</u> , V35/V36-ADAPTER
	[FRMRANZ]	0... <u>2</u> ...255
	LPUFADR	1...4
	[MAXIFL]	1... <u>4096</u>
	[MODTAKT]	<u>JA</u> (YES)
	[NRZI]	<u>NEIN</u> (NO)
	[OPTIONS]	<i>list</i> ([1] [,2] [,4] [,7] [,8] [,10] [,12] [,13]) Default: (2, 8)
	[PROFIL]	NEA <u>ISO</u> NTP
	[PRTIMER]	3000...60000 for X.21 Default: 3000
	[PRTIM2]	100...500... <u>3000</u>
	[RCB]	<u>0</u> ...65535
	[RUF]	AUTO AUTO/ANK, AUTO/ABG

Table 48: KOGS parameters for X.32

Macro	Operands	Operand values
	[RUFNUM]	<i>call number</i> up to 24 characters
	[RUFPAUS]	<u>6</u> ...120
	[RUFWDH]	0... <u>3</u> ...7
	[TPAUSE]	<u>NEIN</u> (NO), JA (YES)
	[UEGSW]	1200... <u>9600</u> ...19200 for V24DEF (increases to 64000 for DUETYP=V35/36-ADAPTER) 1200... <u>9600</u> ...19200, 48000, 64000, 128000, 256000, 512000, 1024000, 2048000 for X21DEF
	[UEKONF]	<u>PZP</u> MP
	[UEPROZ]	<u>HDLC/UNB</u> (for MODE = IBM) <u>HDLC/BAC</u> (otherwise)
	[UEUNB]	<u>PRI/DX</u> PRI/HX SEC/HX SEC/DX
	UEWEG	FE-WAHL/4DR
	[V24DEF]	STD
	[WDHZAHL]	0... <u>3</u> ...255
	[X21DEF]	<u>DBP</u>
XSNID	ADRTYP	X21_ADR or X21-ADR for X.21 switched connections PT_ADR or PT-ADR for telephone network
	SUBNID	PT-i, i=1...32 for telephone network
XZSTW *	DTEADR	<i>decimal number</i> max. 17 positions
	[FACIL]	<i>name</i> max. 8 characters

Table 48: KOGS parameters for X.32

Macro	Operands	Operand values
	[LPUFADR]	1 2 3 4
	NAME	<i>name</i> (in compliance with TRANSDATA conventions), max. 8 characters
	NETZTYP	X25/TYP5 for the packet switching network TRANSPAC in France X25/Typ6 for packet switching network in accordance with CCITT 1980 X25/TYP8 for packet switching network in accordance with CCITT 1984
	[RUFNUM]	<i>call number</i> up to 24 characters
	[SKANABG]	1...4095 - 1...4095
	[SKANALN]	1...4095 - 1...4095
	[SKANANK]	1...4095 - 1...4095
XSYSP		

Table 48: KOGS parameters for X.32

* For an active connection setup (X.32 dial-out), the XZSTW macro that describes the X.25 access is identified either by its name, i.e. the name assigned to the selected route with the FACIL attribute *x25-description*, or by the call number assigned to the selected route in the SNPAROUTES attribute *x32-phone-nr* (first part of the address).

For a passive connection setup (X.32 dial-in), the XZSTW macro is identified by its name, which is assigned to the local telephone line (subnet ID) with the SUBNET attribute *x25-description*.

10.2.2 FSS parameters

For more information on the individual object classes and attributes, see chapter “FSS configuration” on page 269.

Object class FACIL: Define facilities

Attribute	Format	Meaning
name	1-15 characters comprising letters, digits, and the special characters _ and #. A distinction is made between uppercase and lowercase. The first character must not be a digit or an underscore ‘_’.	Name of the FACIL object
facil	See <i>name</i>	Name of another FACIL object that is referenced
npid	NEA OSI-CONS PRIVATE	Network protocol ID
x25-octet-string	1...109 octets in hex format	DTE facilities in accordance with CCITT X.25 Annex G (IS8208)
x25-packet-size	Send direction[/receive direction] with the individual values for S/R: 16 32 64 128 256 512 1024 2048. If R is not specified, R=S.	Packet size
x25-window-size	Send direction[/receive direction] with the individual values for S/R: 1-7, if XFACI PAKNUM=MOD8 1-127, if XFACI PAKNUM=MOD128	Window size
x25-throughput	Send direction[/receive direction] with the individual values for S/R in Kbit/s: 2,4 4,8 9,6 19,2 48 64	Throughput class

Table 49: Attributes of the FACIL object class

Attribute	Format	Meaning
x25-cug	0-9999. Leading zeros are evaluated: 1-2-digit input means 'basic format'; 3-4-digit input means 'extended format'.	Selection of closed user group
x25-cug-oa	0-9999. See <i>x25-cug</i>	Selection of a closed user group with outgoing call
x25-bcug	0-9999. Leading zeros are not evaluated. The "extended format" must always be used.	Selection of a bilaterally closed user group
x25-revch	B[OTH_REQ_AND_ACC] R[EQUEST_ONLY] A[CCEPT_ONLY] N[EITHER_REQ_NOR_ACC]	Request reverse charges or accept request for reversed charges
x25-transit-delay	0-65534 milliseconds	Desired transmission time
x25-fast-select	N[O-RESTRICTION] R[ESTRICTION]	Fast Select (short dialog using the Call User Data field)
x25-rpoa	DNIC[+DNIC...] with a maximum of 12 elements	Selection of a route via one (or more) transit hosts identified by their DNIC (Data Network Identification Code)
x25-nui	Max. 16 printable characters (ASCII, EBCDIC) or max. 16 hexadecimal digit pairs: Format: <i>formind:nui-value</i> formind = A E X	Network User Identification
x25-description	Name of a XZSTW macros (in compliance with TRANSDATA conventions)	Selection of a predefined description of the X.25 access

Table 49: Attributes of the FACIL object class

Object class LOCNSAP: Local host

You will need to make a LOCNSAP entry only for the Transport Service Provider NEA (WAN-NEA and WAN-NX25 profiles).

Attribute	Format	Meaning
name	1-32 printable and visible characters	Name of the LOCNSAP object
nea-addr	<i>p/r</i> where <i>p</i> and <i>r</i> are decimal numbers (0 ... 255)	NEA address: processor/region number

Table 50: Attributes of the LOCNSAP object class

Object class NSAP: Remote network service access point

If you are configuring pure or private X.25 applications, you need not define the network addresses of your partner systems. The NSAP entries are dropped.

Attribute	Format	Meaning
name	1-32 printable and visible characters	Name of the NSAP object
nea-addr	<i>p/r</i> where <i>p</i> and <i>r</i> (0 ... 255)	NEA address: processor/region number
net*	NEA OSI-CONS	Network used by the local system to reach the NSAP
access*	DIRECT	Access to the SNPA address via which the NSAP can be reached
snpa-list	<i>snpa+snpa+...+snpa</i> with max. 20 list elements. <i>snpa: name name/weight</i> <i>name: see name under SNPAROUTES</i> <i>weight: digit from 1-20.</i>	List of alternative SNPAROUTES objects that can be used to reach this NSAP. The priority can be specified with a value for <i>weight</i> (20 is the highest priority).

Table 51: Attributes of the NSAP object class

* The “net” and “access” attributes need not be specified in the configuration file or in the *create* command (*fssadm create NSAP...*), since they are implicitly derived from other attributes.

Additional filter criteria that are only permitted for *fssadm get*:

Attribute	Format	Meaning
type	X32-PTMSA	Subnet address type
subnet	PT- <i>n</i> <i>n</i> = 1, ..., 32	Subnet ID

Table 52: Filter attributes of the NSAP object class

Object class REMSNPA: Remote subnetwork prots

Attribute	Format	Meaning
name	1-15 characters comprising letters, digits, and the special characters _ and #. A distinction is made between uppercase and lowercase. The first character must not be a digit or an underscore ‘_’.	Name of the REMSNPA object
facil	See <i>name</i>	Name of a FACIL object
x32-phone-nr	<i>phone-no/x25-dte-addr</i> <i>phone-no</i> : up to 24 characters <i>x25-dte-addr</i> : up to 17 characters	X.32 via telephone network
type	X32-PTMSA	Subnet address type

Table 53: Attributes of the REMSNPA object class

Object class SNPAROUTES: Routes**Association between subnet address type and subnet ID**

Depending on the subnet address type, you can assign the subnet ID as follows:

Subnet addr. type	Subnet ID
X32-PTMSA	PT-x

Table 54: Assignment of subnet ID to subnet address type

Attribute	Format	Meaning
name	1-15 characters comprising letters, digits, and the special characters _ and #. A distinction is made between uppercase and lowercase. The first character must not be a digit or an underscore '_'.	Name of the SNPAROUTES object
rem-snpa*	See <i>name</i>	Name of a REMSNPA object that represents the remote subnetwork address
facil	See <i>name</i>	Name of a FACIL object
subnet	PT- <i>n</i> <i>n</i> = 1, ..., 32	Subnet ID

Table 55: Attributes of the SNPAROUTES object class

* Alternatively, one of the SNPA addresses (“x32-phone-nr”) listed under the REMSNPA object class may be directly specified.

10.2.3 TNS parameters

Detailed information on the TNS and on the TNS entries for the program interface can be found in the “CMX, Operation and Administration” User Guide [1].

The TNS entries depend on the used profile and may vary accordingly. Depending on which applications expand on the CMX, session components (SSEL) and presentation components (PSEL) may also be specified. See the “CMX, Operation and Administration” User Guide [1] for details.

WAN-NX25

TNS entries for the local application:

Global name	Type	Addr. format	T-selector
<i>Global name</i>	TSEL	WANNEA	{T A E X} string <i>string with max. 8 characters</i>

TNS entries for the remote application:

Global name	Type	Addr. format	Addr. component
<i>Global name</i>	TA	WANNEA	{T A E X} string <i>string with max. 8 characters</i> processor/region (0...255/0...255) [WAN cc-no:line identifier]

WAN-CONS with X.25

TNS entries for the local application:

Global name	Type	Addr. format	T-selector
<i>Global name</i>	TSEL	WANSBKA	{T A E X} string <i>string</i> mit max. 10 characters

TNS entries for the remote application:

Global name	Type	Addr. format	Addr. component
<i>Global name</i>	TA	WANSBKA[X.32 <i>telnr</i> X.121 X.25-dte address osi-nsap-address (X.25) {T A E X} string <i>string</i> with max. 8 characters after T <i>string</i> with max. 32 characters after A, E and X [TPI] [TPC] [WAN cc-no:line identifier]

WAN-X25

TNS entries for the local application:

Global name	Type	Addr. format	T-selector
<i>Global name</i>	TSEL	WAN3SBKA	{T A E X} string <i>string</i> with max. 8 characters

TNS entries for the remote application:

Global name	Type	Addr. format	Addr. component
<i>Global name</i>	TA	WAN3SBKA	X.32 <i>telnr</i> X.121 X.25-dte address [T A E X] string <i>string</i> with max. 8 characters after T <i>string</i> with max. 32 characters after A, E and X [WAN cc-no:line identifier]



So long as the phone link to the X.25 network exists, remote X.25 connection setup requests will also be delivered to you. For example, if the TNS entry is TA WANSBKA X.32 1234 X.121 5678 A'example',

the CCP profile will report a connection setup request with the sender address "TA WANSBKA X.121 5678 A'example'" to the application. The first dialing step, i.e. the phone number 1234, is not delivered with it. Some applications check whether the remote sender address was entered in the TNS before they accept a connection. In such cases, besides the GLOBAL NAME 'example', you must create a second entry that matches 'example', but does not include the call number:

```
TA WANSBKA X.121 5678 A'example'
```

10.3 Configuration using the menu system

This section describes configuration using the menu system *CMXCUI*.

10.3.1 Configuring the local subnetwork interface

Menu	Choice
CMX Main Menu	CFs - CCP Configuration Files...
Select Network Access	WAN
Configuration Files for WAN Network Access	a) Change CF: MARK , ENTER b) Create new CF: ENTER
Operations on CFs	Create... or Edit
Create a New File	Name of configuration file: <i>name</i> Type of CC to create for: <i>cc-type</i>
When you SAVE the entries, a submenu to create the configuration file name for the selected CC type appears:	
Edit configuration file <i>name</i> for <i>cc-type</i>	Select one of the displayed lines with V.24 interface.
Configuration for WAN Interface <i>no</i>	Local
Configure local network interface	Subnetwork: Te1->X.25_(X.32) Subnet ID: PT-n Own telephone number: Default transport protocol: NEA
Parameter for Interface <i>no</i> to <i>network</i>	Modify line parameters or accept the default values, e.g. for transmission speed, link address, NRZI, for setting up the dial-up connection, HDLC protocol variant, various timers, multilink, XID exchange
Configuration for WAN Interface <i>no</i>	X.25
X.25 Integration (X.32) via Interface <i>no</i>	DTE Name: (Name of a XZSTW macro) Telephone Number: (call number of the X.25 transition)

Menu

X.25 Parameters for DTE *name* with
Call Number *no*

Choice

DTE address of transit system:
Channel ranges for SVCs:
X.25 facilities arranged:

If you have specified *X.25 facilities arranged: yes*, a further menu to create facilities will appear.

Configuration for WAN Interface *no*

Compile

Configuration for WAN Interface *no*

Exit

Generating the configuration file

When you have completed the input for your own subnetwork interface and for the remote systems, exit the configuration menu. This causes a KOGS source file to be generated automatically and compiled into a configuration file.

In order to ensure that your configuration entries take effect, you must assign the WAN network access and the generated configuration file to a Communications Controller and load the Communications Controller. See the section "Assigning network access software and configuration file to a CC" on page 66.

10.3.2 Defining routes

Menu

CMX Main Menu

Routes to Remote Subnetwork Interfaces

Operations on Routes to Remote Subnetwork Interfaces

Attributes of a Route

Choice

SNPAROUTES - Routes to Remote Subnetwork Interfaces

a) Change route: ,

b) Create new route:

Create... or Change...

Name: *name*

Type of remote subnet address:

X32-PTMSA

Subnet ID:

(must match the subnet ID in the CF)

Telephone number:

X.25 DTE address:

Facilities:

If you have specified *Facilities: yes*, a further menu to create facilities will appear:

Facilities to Route [*name*]

Admission:

Use PPP Subprofile:

Network Protocol ID:

Van-Jacobsen-Header-

Compression:

Use T70 Subprofile:

Menu**Choice**

Once you have saved, you will see a further window.

X25 Subnet Facilities to Route [name]	Packet Size outgoing: Packet Size incoming: Window Size / outgoing: Window Size / incoming: Throughput / outgoing: Throughput / incoming: Closed User Group: User group with outgoing access: bilateral Closed User Group: Reversed Charging: Transit Delay: Fast Select: RPOA Selection:
---------------------------------------	---

10.3.3 Entering partner systems

Menu

CMX Main Menu

Remote Hosts ...

Operations on Remote Systems

Remote NSAP Information

Choice

NSAPs - Remote Hosts ...

a) Remote Hosts ... Change:

,

b) Remote Hosts ... Create:

Create... or Change...

Name: *name*

Network: NEA

Processor-/Region number:

Subnet Address:

- Static routes: The SNPA address for this partner system is specified directly.

f

- Via Intermediate System: The partner system is reached via an intermediate system for which the determination of the SNPA address is already defined.

10.3.4 Entering transport system applications

This section briefly describes the individual worksteps in the CMX menu system in the form of an overview. A detailed description can be found in the "CMX, Operation and Administration" User Guide [1].

Menu	Choice
CMX Main Menu	TSAs - Transport System Applications
GLOBAL NAME of TS Application	a) Change global name: [CHOICES], [ENTER] b) Create new global name: specify name part [1] - [5] (all name parts are optional)
Operations on TS Applications	Assign LOCAL NAME... CCP profile: WAN-NEA T-selector:
Operations on TS Applications	Assign transport address... (entry for remote transport system application) CCP profile: WAN-NEA Station name of TS application: Name of the remote system: TRANSDATA network address: CC list:

10.4 Examples

10.4.1 X.32 dialing with the WAN-NX25 profile

Active side

TNS entries

```
R1_12_0000.Part1.nx25-1c01-128.XXX \
    TSEL WANNEA T'XXX10000'
R1_21_0000.Part2.nx25-1c01-128.XXX \
    TA WANNEA ( T'XXX20000' 60/18 )
```

FSS entries

The entry in the SNPAROUTES object is of primary importance:

- The subnet type is the telephone network PT-..
- The call number consists of the phone number of the X.25 exchange and the DTE address of the remote X.25 partner system (end system).
- Selecting the appropriate X.25 access (if more than one is possible!):

The name of the associated XZSTW macro in the KOGS source is specified in the FSS in the x25-description parameter of the FACIL object.

```
LOCNSAP ( name=PGTR0023 nea-addr=23/18 )
FACIL ( name=x25ph77777 x25-description=$NEBEN01 )
SNPAROUTES ( name=R1 subnet=PT-1 x32-phone-nr=4846/99999
             facil=x25ph77777 )
NSAP ( name=N1 nea-addr=60/18 net=NEA access=DIRECT
       snpa-list=R1 )
```

KOGS source file

Special aspects to be noted in the KOGS:

The entries are the same as the default for X.25, but differ from the standard entries for normal telephone lines!:

```
NRZI = NEIN
```

```
XSYSP
```

```
XSNID  ADRTYP = PT_ADR,  
        SUBNID = PT-1
```

```
XLTNG  LPUFADR = 1,  
        RUFNUM = 4841,      # Phone number of local  
                             port
```

```
        DUETYP = MODEM,
```

```
        NRZI = NEIN,
```

```
        UEGSW = 2400,
```

```
        UEKONF = PZP,
```

```
        UEPROZ = HDLC/LAPB,
```

```
        UEWEG = FE-WAHL/4DR, # Switched telephone network
```

```
        V24DEF = STD
```

XZSTW describes the X.25 exchange that is dialed via the telephone network:

```
XZSTW  NETZTYP = X25/TYP9,
```

```
        LPUFADR = 1,
```

```
        NAME = $NEBEN01,
```

```
        RUFNUM = 4846,      # Phone number of the dialed  
                             X.25 node
```

```
        DTEADR = 77777,    # Own DTE address at  
                             exchange
```

```
        SKANALN = 1-10     # SVC range
```

```
XEND
```

Passive side

FSS entries

Distinguishing characteristics as opposed to the active side:

- Only one XZSTW macro can be assigned to the local telephone line at any one time. This means that it is not possible to receive calls from multiple X.25 packet handlers. The assignment is made by a SUBNET object with the attributes *subnet* (subnet ID of the local telephone line) and *x.25-description* (name of the XZSTW).

Required FSS entries:

X.25 facilities that were agreed with the X.25 partner:

```
FACIL ( name=x25rem x25-revch=REQUEST_ONLY )
```

The following route entry describes the remote partner:

```
SNPAROUTES ( name=R1 subnet=PT-1 x32-phone-nr=4841/77777  
              facil=x25rem )  
NSAP ( name=N2 nea-addr=23/18 snpa-list=R1 )
```

The following route entry is required to enable the detection of an X.25 profile in an incoming call:

```
SUBNET ( subnet=PT-1 x25-description=XZSTWOK )
```

KOGS source file

```

XSYSP
XSNID  SUBNID = PT-1,
        ADRTYP = PT_ADR

```

Facilities that were agreed with the network provider for the own X.25 port:

```

XFACI  FACIL = FACLOC,
        WINDE = 5,
        WINDS = 5
XLTNG  RUFNUM = 4846,
        NRZI = NEIN,
        LPUFADR = 1,
        DUETYP = MODEM,
        MODE = CCITT,
        UEKONF = PZP,
        UEPROZ = HDLC/LAPB,
        UEWEG = FE-WAHL/4DR,
        UEGSW = 2400,
        WDHZAEL = 3,
        OPTIONS = (2,8),
        V24DEF = STD
XZSTW  NETZTYP = X25/TYP9,
        DTEADR = 99999,      # Own DTE address
        RUFNUM = 4841,      # Call number of the X.25
                             # packet handler
        SKANALN = 1-1,
        NAME = XZSTWOK,     # For identification from FSS
        FACIL = FACLOC
XEND

```

11 Configuration with KOGS macros

In order to use CCP-WAN, you must first configure the appropriate WAN products (including any add-on products such as TRANSIT-SERVER, etc.). The CCP-WAN configuration describes the characteristics of the X21 or X25 network as well as the local subnetwork connection. It is stored in a configuration file (CF).

Configuration involves assigning specific values to operands. These operand values are partly dependent on the network connection and operating characteristics. Some network-specific parameters must therefore be requested from the network provider before the configuration if they were not supplied when requesting the connection.

You can create a configuration file (CF) in two ways:

- by using the menu system (see section “Editing configuration files with the menu system” on page 64)
- by editing a configuration file with KOGS macros (see section “Editing a configuration file in expert mode” on page 65 and the current chapter)

You can create a standard configuration, which is adequate for most cases, with the menu-controlled configuration; however, more configuration operands will be available to you when creating a CF with KOGS macros.

If you work exclusively with the menu system, a KOGS source file is created and then compiled (more or less automatically) to create a configuration file. You do not see the KOGS source file. It is this KOGS source file that you have to edit with an editor in expert mode. In this case, you must initiate compilation explicitly in order for a configuration file to be generated.

 You should only create a CF with KOGS macros if the standard configuration does not fulfill your requirements. We recommend that you first create a KOGS source file via the menu system and then edit it.

The following points must be noted when editing a KOGS source file created with the menu system:

- A KOGS source file created with the menu system can only be directly edited with the menu system. If you want to use a text editor to edit a file created with the menu system, you must first make a copy of that file. You can then adapt this copy with a text editor as needed.
- A KOGS source file that is created or edited with a text editor cannot be edited later with the menu system.

11.1 Creating a configuration file

The following sections describe the process of creating a configuration by editing a KOGS source file. All the information required to create a configuration file with KOGS (configuration-oriented generator language) is presented here.

KOGS is a “configuration-oriented generator language” that can be used to formulate a configuration in a KOGS source file. The subsequent compilation of this KOGS source file creates a configuration file (CF). This configuration file is loaded when CCPWAN is started up. The configuration file consists of a number of macros with system and line-specific operands.

Operands are classified as mandatory or optional:

- You must assign a value to mandatory operands.
- With optional operands, you can choose whether you want to assign a value. If you do not assign a value to an optional operand, CCP-WAN uses the predefined default value internally. In the following macro descriptions, all default values are shown underlined.

Compiling a KOGS source file

After you have edited the KOGS source file to suit your requirements, close the file and exit the editor. Compile the KOGS source file with the corresponding function of the menu system (see section “Compiling a KOGS source file” on page 65). The result of compilation is a configuration file (CF), which is subsequently loaded when CCP-WAN is started and sets the required CCP-WAN configuration. Self-explanatory error messages are displayed on the screen if errors occur during compilation. If this happens, correct the KOGS source file and then recompile it.

Assigning a configuration file to a Communications Controller

After that you assign the configuration to a specific Communications Controller (CC) (see the section “Assigning and loading the configuration file” on page 66). You can also use the *exchange* command for this purpose. Information on this command can be found in the section “Administration commands” on page 293.

11.1.1 Syntax rules for KOGS source files

This section describes the syntax rules for calling macros and operands and inserting comments in a KOGS source file.

Calling macros

The following rules must be observed when calling a macro from within the KOGS source file:

- A macro is called by specifying its name and operands.
- Macro names are detected from the second column on. They must therefore always be preceded by at least one blank.
- No distinction is made between uppercase and lowercase.
- The first operand in a macro must be in the same line as the macro name. Note that the maximum line length in a KOGS source file must not exceed 71 characters.
- A macro name is terminated with a blank or end-of-line character. Any required number of comment or blank lines are allowed either before, after or between macro specifications.
- The various macros in a source file must be called in a specific order. Information on the call sequence can be found in the section “Overview of KOGS macros” on page 229.

Calling operands

The following rules must be observed when specifying an operand in the KOGS source file:

- Operands are character strings that must be specified in the form *keyword=value*, where *keyword* represents the respective operand name, and *value* is the assigned value.
- Any number of blanks are permitted before and after the equals sign; however, an operand must be fully defined within a line.
- The maximum line length in a KOGS source file must not exceed 71 characters
- The individual operands of a macro are delimited by commas. These commas must follow directly after the operand value, without intervening blanks or new lines. The last operand in a macro is not followed by a comma

- No distinction is made between uppercase and lowercase.
- The operands within a macro can be in any order.
- Operands within a macro must not be separated by blank or comment lines.

Comments

The following comment options are available:

- A comment can be initiated by an * (asterisk) or the # (number sign) in the first column. It can extend over the complete length of the line (comment line). A comment line must not separate operands within a macro.
- A comment can be initiated by a ; (semi-colon) and extend to the end of the line (line comment). Every line in a KOGS source file can contain a line comment after macro names, operands or a comment character.
- All strings that start in the first column are taken to be comments. They can be followed by a macro name, separated by at least one blank.
- The maximum line length in a KOGS source file must not exceed 71 characters.
- A blank line is also taken to be a comment. It may consist of no characters (just the end-of-line character) or blanks and the end-of-line character.

Example of a KOGS source file with the correct syntax

1st column



```
* S A M P L E - K O G S
#   2nd comment line
*
*   .
# (any number of comment lines)
*
*   .
*       XSYSP
#
* The macro call must not be interrupted by
* comment or blank lines
#
*       XLTNG LPUFADR = 1
*
*
*       XEND           ; End of KOGS (comment within line)
#
# (any number of comment lines and blank lines)
*
*       .
```

11.1.2 Call sequence for KOGS macros

The macros must be called in a specific order within a KOGS source file. Any violation of the required call sequence will result in syntax errors during the compilation of the KOGS source file. The order and call number of the individual macros are described in table 56.

Call sequence:

Macro	Meaning	Max. number of calls	Mandatory macro?
XSYSP	Open KOGS	1	yes
XSNID	Define local subnetwork interface	1 - 4	yes
XFACI	Define X.25 facilities and parameters	0 - any	no
XLTNG	Define line operands	1 - 4	yes
XZSTW	Define X.25 attributes with two-step dialing	0 - any	no
XPRO	Define link addresses and XID exchange	1 - 4	no
XEND	End KOGS	1	yes

Table 56: Call sequence for macros in the KOGS source file

11.2 Overview of KOGS macros

This section contains an overview of KOGS macros, together with the operands relevant for CCP-WAN and their permitted value ranges. The macros are listed in alphabetical order. This is followed by detailed descriptions of the individual KOGS macros and their operands.

Entries for optional operands are enclosed within square brackets [...]. The brackets must not be entered.

XEND macro:

Operands	Operand value	Meaning
Without operands	None	Syntactic end of the KOGS source file

Table 57: Operands of the XEND macro

XFACI macro:

Operands	Operand value	Meaning
[AKFACI]	<u>NOREVCH</u> REVCH FASTSEL <i>list</i>	For SVCs only. Reverse charging and Fast Select Acceptance for an incoming call
[DTEADCA]	JA (YES) TOANPI SUPLAD <i>list</i>	Specifies if the DTE address is to be entered in the call accept packet on accepting an X.25 call, or defines the DTE address format
FACIL	<i>name</i> (max. 7 characters)	Name of X.25 facilities
[NUI]	<i>string</i>	Network User Identification assigned by the network provider
[PAKLE]	16... <u>128</u> ...2048 (power of 2)	Packet length in receive direction in bytes

Table 58: Operands of the XFACI macro

Operands	Operand value	Meaning
[PAKLS]	16... <u>128</u> ...2048 (power of 2)	Packet length in send direction in bytes
[PAKNUM]	<u>MOD8</u> MOD128	Modulo format for X.25 packet numbering
[R20]	1... <u>10</u> ...128	Retry counter for restart request
[R22]	1... <u>10</u> ...128	Retry counter for reset request
[R23]	1... <u>2</u> ...128	Retry counter for clear request
[T20]	1... <u>10</u> ...2048	Monitoring period for restart request
[T21]	1... <u>200</u> ...2048	Monitoring period for connection request
[T22]	1... <u>10</u> ...2048	Monitoring period for reset request
[T23]	1... <u>10</u> ...2048	Monitoring period for clear request
[T24]	<u>0</u> ...2048	Monitoring period for sending an RR or RNR packet
[T25]	0... <u>180</u> ...2048	Monitoring period for outstanding acknowledgment of data packets
[WINDE]	1... <u>2</u> ...7 (for PAKNUM = MOD8) 1... <u>2</u> ...127 (for PAKNUM = MOD128)	Number of unacknowledged data packets that may be sent from the network
[WINDS]	1... <u>2</u> ...7 (for PAKNUM = MOD8) 1... <u>2</u> ...127 (for PAKNUM = MOD128)	Number of unacknowledged data packets that may be sent into the network

Table 58: Operands of the XFACI macro

XLTNG macro:

Operands	Operand value	Meaning
[CTIMER]	<u>0</u> ...450	Delay of data after setting the C signal
[DTEADR]	<i>decimal value</i>	Own DTE address (X.25 main call number)
[DUETYP]	<u>MODEMDIREKT</u> V35/V36-ADAPTER	Type of data circuit-terminating equipment
[FACIL]	<i>name</i> (max. 7 characters)	Reference to the XFACI macro
[FRMRANZ]	0... <u>2</u> ...255	Maximum number of times an FRMR frame is output
LPUFADR	1...4	Identification of a line port
[MAXIFL]	1... <u>4096</u>	Maximum information frame length excluding address and control field
[MLNK]	1...9	Bundle number of a multilink bundle
[MODE]	<u>SIE</u> IBM	Specifies a vendor-specific protocol variant
[MODTAKT]	JA (YES) NEIN (NO)	Specifies whether the send pulse rate is generated externally or by the buffer itself
[NRZI]	<u>NEIN</u> (NO) (for UEPROZ=FR or X.25 port) <u>JA</u> (YES) (otherwise)	Procedure for defining the signal coding on the line
[OPTIONS]	<i>list</i>	Generation of HDLC protocol variants
[PKANALN]	<i>a-z</i> $0 \leq a \leq z \leq 4095$	Range of logical X.25 channels for PVCs

Table 59: Operands of the XLTNG macro

Operands	Operand value	Meaning
[PLIDENT]	<u>NEIN</u> (NO) <i>hexvalue</i>	Own identification which controls identification exchange between directly connected systems
[POLLPAU]	0, 100...3600 <u>500</u> (for HDLC/UNB) <u>0</u> (otherwise)	Minimum interval before start of next poll cycle
[PROFIL]	NEA ISO NTP SDLC PPP	Specifies the transport protocol. Determines the default profile if no transport system was specified at connection setup.
[PRTIMER]	100...60000 <u>3000</u> (for X.25) otherwise default depends on MAXIFL and UEGSW	Monitoring period for the HDLC protocol during the data phase
[PRTIM2]	100...3000 <u>3000</u> (for X.25 port) <u>500</u> (otherwise)	Monitoring period for the HDLC protocol during the scaling phase
[PRTIM3]	<u>0</u> ...60000 0... <u>65000</u> ..6000000 (for UEPROZ= HDLC/UNB and UEUNB= SEC/...)	Set partner monitoring
[RCB]	<u>0</u> ...65535	Number of retries for monitoring a "busy" condition of remote data terminal equipment
[RUF]	AUTO AUTO/ANK AUTO/ABGDIREKT DIREKT/ABG MANUELL MANUELL/ABG	Defines how a dial-up connection is established

Table 59: Operands of the XLTNG macro

Operands	Operand value	Meaning
[RUFNUM]	<i>value</i> or ' <i>value</i> ' or " <i>value</i> " (max. 24 characters)	Own call number
[RUFPAUS]	<u>6</u> ...120	Specifies the time for the interval between call retries
[RUFWDH]	0... <u>3</u> ...7	Number of call retries if an outgoing call was unsuccessful
[SKANABG]	<i>a-z</i> $1 \leq a \leq z \leq 4095$	Numbers of the logical channels for outgoing SVCs
[SKANALN]	<i>a-z</i> $1 \leq a \leq z \leq 4095$	Numbers of the logical channels for incoming and outgoing SVCs
[SKANANK]	<i>a-z</i> $1 \leq a \leq z \leq 4095$	Numbers of the logical channels for incoming SVCs
[TPAUSE]	<u>NEIN</u> (NO) JA (YES)	Specifies whether there should be a pause between two frames
[UEGSW]	1200... <u>9600</u> ...19200 (for V24DEF) 2400... <u>9600</u> ...64000 (for DUETYP=V35/36-ADAPTER) 1200... <u>9600</u> ...19200, 48000, 64000, 128000, 256000, 512000, 1024000, 2048000 (for X21DEF)	Transmission speed
[UEKONF]	<u>PZP</u> MP	Transmission configuration of the HDLC connection
[UEPROZ]	<u>HDLC/LAPB</u> (for X.25 port) <u>HDLC/UNB</u> (if MODE = IBM) <u>HDLC/BAC</u> (otherwise) FR (for frame relay)	Type of transmission protocol

Table 59: Operands of the XLTNG macro

Operands	Operand value	Meaning
[UEUNB]	<u>PRI/DX</u> PRI/HX SEC/HX SEC/DX	Defines the function of the HDLC protocol
UEWEG	X25/TYP5, X25/TYP6, X25/TYP8, X25/TYP9, X25/TYP56, X25/TYP58 FE-STAND/2DR FE-STAND/4DR FE-WAHL/2DR FE-WAHL/4DR DATEX-L DATEX-L/X21 DATEX-L/V24	Transmission path
[VUEZEIT]	0... <u>24</u> ...127	Connection monitoring
[V24DEF]	<u>STD</u>	V.24 interface
[WDHZAHL]	0... <u>3</u> ...255	Number of retries after unsuccessful polling/selecting and unsuccessful block transfer in the HDLC protocol
[X21DEF]	<u>DBP</u>	Definition of X.21 facilities

Table 59: Operands of the XLTNG macro

XPRO macro:

Operands	Operand value	Meaning
[LINKADR]	(1...3...254,1...254) (own, partner) 1...222	Specifies the HDLC link addresses of partner systems; only relevant for dedicated lines
[PRIDENT]	<i>hexvalue</i> (for MODE=SIE: max. 12x2 bytes, otherwise: max. 48 bytes)	Identification of the remote system. For dial-up lines only
[RUFNUM]	<i>value</i> or ' <i>value</i> ' or " <i>value</i> " (max. 24 characters)	Call number of the remote system. For dial-up lines only

Table 60: Operands of the XPRO macro

XSNID macro:

Operands	Operand value	Meaning
ADRTYP	X25-ADR X21-ADR HDLCPP PT-ADR FR-PVC	Address type; specifies the type of subnetwork
SUBNID	X25-i, i=1...32 X21-i, i=1...32 PP-i, i=1...32 PT-i, i=1...32 FR-i, i=1...128	Unambiguous identification for every subnetwork port (subnet ID)

Table 61: Operands of the XSNID macro

XSYSP macro:

Operands	Operand value	Meaning
Without operands	None	Syntactic start of the KOGS source file

Table 62: Operands of the XSYSP macro

XZSTW macro (only for two-step dialing):

Operands	Operand value	Meaning
DTEADR	<i>decimal digit</i>	Own DTE address, i.e. DTE address of the intermediate system (X.25 main call number)
[FACIL]	<i>name</i> (max. 7 characters)	Reference to the XFACI macro
[LPUFADR]	1...4	Identification of the line port (= LPUFADR in the XLTNG macro)
[NAME]	<i>name</i> (max. 8 characters)	Name of the macro. This name must match the entry in the FSS (FACIL object class, x25-description=).
NETZTYP	X25/Typ6 X25/TYP8 X25/TYP9 X25/TYP56 X25/TYP58	Network type of the X.25 network
RUFNUM	<i>value</i> or ' <i>value</i> ' or " <i>value</i> " (max. 24 characters)	Call number of the X.25 node to be dialed
[SKANABG]	<i>a-z</i> $1 \leq a \leq z \leq 4095$	Range of numbers for logical channels to be reserved exclusively for outgoing SVCs
[SKANALN]	<i>a-z</i> $1 \leq a \leq z \leq 4095$	Range of numbers for logical channels to be reserved exclusively for incoming and outgoing SVCs
[SKANANK]	<i>a-z</i> $1 \leq a \leq z \leq 4095$	Range of numbers for logical channels to be reserved exclusively for incoming SVCs

Table 63: Operands of the XZSTW macro

11.3 KOGS macros

This section contains a detailed description of the KOGS macros and their operands. The description is arranged in alphabetical order.

11.3.1 XEND - end of a KOGS source

XEND is the last macro in a KOGS source file. This macro is mandatory and has no operands.

11.3.2 XFACI - define facilities

The XFACI macro is used to define connection-specific X.25 facilities and X.25 parameters. The XFACI macro is optional.

X.25 facilities are selectable X.25 features. Connection or partner-specific X.25 parameters, which can be negotiated if necessary, must be entered in the FSS (see chapter “FSS configuration” on page 269).

They depend on the services offered or requested by the network provider and must be coordinated with the network provider.

The XFACI macro also includes several X.25 parameters which are rarely modified. These include the retry counters and the monitoring periods. These values can be modified without coordinating them with the network provider.

The XFACI macro always interacts with the X.25 interface and is thus inter-related with the XLTNG macro (in the case of a direct X.25 port) and the XZSTW macro (in the case of an X.25 interface via two-step dialing).

[AKFACI]

For SVCs only (see the description of a switched virtual call in section “Virtual connection” on page 12).

You define the behavior relating to reverse charging and Fast Select Acceptance for an incoming call.

= NOREVCH

Incoming calls on this line with requests for reverse charging are only accepted by partners for which reverse charging has been configured in the FSS.

= REVCH

Incoming calls on this line with requests for reverse charging are accepted. It is not possible to configure partner-specific exceptions. If this operand value is not specified, incoming calls with requests for reverse charging will only be accepted by the partners for whom the acceptance of reverse charges was configured in the FSS.

= FASTSEL

If Fast Select Acceptance has been agreed with the partner, it is set up with this macro. With this setting the incoming call with its facilities is shown. The higher levels can react in accordance with the FSS entry.

If this operand value is not specified, incoming calls requesting the Fast Select facility are rejected with the following message: *Fast Select not subscribed*.

= *list*

list permits the above operands to be listed a number of times. The operands must be separated by a comma and enclosed in brackets. At least two operands must be specified, e.g. REVCH, FASTSEL.

[DTEADCA]

Specifies if DTE addresses are to be entered in the call accept packet when an X.25 call is accepted, or defines how the DTE address block is structured in various packets. This specification depends on the network. The appropriate values can be obtained from the network provider.

= JA (YES)

DTE addresses are transferred, i.e. entered into the Call Accepted packet. This value is useful for a DTE-DTE link or DCE generation. If this operand value is omitted, DTE addresses are not entered in the Call Accepted packet.

= TOANPI

The DTE address in the packets must be specified in TOA/NPI format in accordance with the CCITT 1988 standard.

This enables you to specify DTE addresses of up to 17 decimal digits (normally only 15 positions).

The first two digits of the DTE address specify the Type of Address (TOA) and Numbering Plan Information (NPI).

The use of TOA/NPI must be agreed with the network provider.

If this operand value is not specified, DTE addresses are entered into packets in the previous (NON-TOANPI) format, i.e. with a maximum of 15 decimal digits.

= SUPLAD

The local DTE (main) address is suppressed in the connection setup packet. Some networks, e.g. TRANSPAC, do not allow the local DTE address to be entered in the Call Request and Call Accepted packet.

= *list*

list permits the above operands to be listed a number of times. The operands must be separated by a comma and enclosed in brackets. At least two operands must be specified, e.g. TONAPI,JA,SUPLAD

FACIL

This operand establishes the connection to an XLTNG or XZSTW macro. The name specified here must also be entered in the FACIL operand of one of these macros. Names are freely selectable within the framework of their syntax, but must be different for all specified XFACI macros.

= *name*

Length: ≤ 7 characters

Characters: A...Z, 0...9, #, @, \$

First character: not equal to 0...9

[NUI]

Network User Identification

A Network User Identification (NUI), which is assigned by the network provider, is placed by the DTE in the Call Request Packet of an outgoing X.25 connection setup. This NUI is used only for identification purposes.

= *string*

is issued by the network provider.

[PAKLE]

This operand can be used to define the receive packet length. The packet length defines the maximum permissible length of the field for user data per data packet. This value must be agreed with the network provider.

The value specified here is used as the default value for all PVCs and SVCs of this interface.

= **16...128...2048**

Packet length in bytes. The value is expressed as a power of 2.

[PAKLS]

This operand can be used to define the send packet length. The packet length defines the maximum permissible length of the field for user data per data packet. This value must be agreed with the network provider.

The value given here is the default value for all PVC and SVC of this interface.

= **16...128...2048**

Packet length in bytes. The value is expressed as a power of 2.

[PAKNUM]

Packet numbering in modulo 8 or modulo 128 format. The value has to be coordinated with the network provider.

= **MOD8**

The packets are numbered from 0 to 7.

= **MOD128**

The packets are numbered from 0 to 127.

[R20] This operand defines the number of times the restart request is to be retried. Retries are carried out after the timeout of the T20 monitoring period. After the timeout of the retry counter, the switched connection is terminated.

= **1...10...128**

Number of retries

[R22] This operand defines the number of times the reset request is to be retried. Retries are carried out after the timeout of the T22 monitoring period. In the case of two-step X.32 dialing, the switched connection is terminated after the timeout of the retry counter.

= **1...10...128**

Number of retries.

[R23] This operand defines the number of times the clear request is to be retried. The retries are carried out after timeout of the T23 monitoring period. Following the timeout of the retry counter, the channel number is cleared and, if this was the only connection, the switched connection is terminated for two-step X.32 dialing.

= **1...2...128**

Number of retries.

[T20] This operand defines the length of the waiting period before resending a restart request. The number of retries is limited by the R20 operand.

= **1...10...2048**

Value specified in seconds.

[T21] This operand defines the length of the waiting period before resending a connection request.

= **1...200...2048**

Value specified in seconds

[T22] This operand defines the length of the waiting period before resending a reset request. The number of retries is limited by the R22 operand.

= **1...10...2048**

Value specified in seconds.

[T23] This operand defines the length of the waiting period before resending a clear request. The number of retries is limited by the R23 operand.

= **1...10...2048**

Value specified in seconds.

[T24] This operand defines the monitoring period for sending an RR (receive ready) or RNR (receive not ready) packet with the receive sequence number P(R). This also applies if no acknowledgments are to be sent. (All received data packets are acknowledged.)

If the operand is not specified (or =0), all unacknowledged data packets are acknowledged after a maximum of 20 seconds, but no periodic transmission of PR and RNR packets occurs.

= **0...2048**

Value specified in seconds.

[T25] This operand defines the monitoring period for the receipt of pending acknowledgments for data packets. The connection is terminated following a timeout.

Time monitoring is initiated whenever a data packet is sent or on switching the window. Time monitoring is terminated when there are no more pending acknowledgments for data packets.

= **0...180...2048**

Value specified in seconds.

[WINDE]

This operand defines the number of unacknowledged data packets that may be received from the network. The value specified here is the default for all PVCs and SVCs of this interface.

= **1...2...7**

Number of data packets for PAKNUM = MOD8

= **1...2...127**

Number of data packets for PAKNUM = MOD128

[WINDS]

This operand defines the number of unacknowledged data packets that may be sent into the network. The value specified here is the default for all PVCs and SVCs of this interface.

= 1...2...7

Number of data packets for PAKNUM = MOD8

= 1...2...127

Number of data packets for PAKNUM = MOD128

11.3.3 XLTNG - define line operands

XLTNG is a mandatory macro that describes the line interface.

To some extent, definitions specified here are dependent on agreements with the network provider. In addition, values specified with the UEWEG operand must be coordinated with definitions you specify with the XSNID macro.

[CTIMER]

This operand delays the transmission of data after the C signal is set. It is relevant if the line leads to an SK12 concentrator, and stations or computers are connected to this SK12 concentrator as HDLC secondary stations via X.21. It is therefore only permissible to specify a value for this operand if UEPROZ=HDLC/UNB and UEUNB=SEC/... are agreed. The SK12 concentrator requires a delay of at least 30 milliseconds. In the case of cascading SK12 concentrators, 30 milliseconds must be calculated for each one.

= 0 No data transmission delay.

= 1...450 Value specified in milliseconds.

[DTEADR]

Own DTE address (X.25 main address). Specification of the DTE (main) address is only permitted for X.25 lines. The German PTT also refers to the DTE address as a call number. This operand is mandatory if SVCs are generated, i.e. if at least one of the operands SKANABG, SKANANK, or SKANALN was generated.

= *decimal value*

A whole, positive, decimal number of not more than 15 digits; assigned by the provider of the packet switching data network.

If you have specified XFACI DTEADCA=TOANPI, you may enter DTE addresses of up to 17 decimal digits.

[DUETYP]

Specifies the type of data circuit-terminating equipment.

= MODEM

Connection via modem link (e.g. X.21 modem).

= DIREKT

Direct connection without a modem. Only permitted for V.24 and only possible for systems that can generate and supply the send pulse rate on the V.24 themselves, e.g. if both partners possess a Fujitsu Siemens Communications Controller.

[FACIL]

Reference to the XFACI macro. Specifies the name of the facilities and parameters for an X.25 port. You must define these facilities and parameters using the XFACI macro:

= *name*

Name specified for the FACIL operand of the XFACI macro.

Length: ≤ 7

Characters: A...Z, 0...9, #, @, \$

First character: not equal to 0...9

[FRERTHR]

Specifies the error threshold for LMI.

Only for FR and option 9:

1, 2...FR and 10

=

Condition: FRERTHR \leq FREVCNT

[FREVCNT]

Reference to the number of events counted in the event history for LMI.

Only for FR and option 9:

1...4...10

=

Condition: FRERTHR \leq FREVCNT

[FRFSCC]

Reference to the number of intervals in a full status cycle for LMI.

Only for FR and option 9:

1...6...255

=

[FRMRANZ]

With HDLC (Balanced, LAPB), FRMRANZ determines the maximum number of times an FRMR frame is output after an "invalid" frame is received.

= **0...2...255**

Number of times an FRMR frame is output.

LPUFADR

Identification of the line port. Each line number can only be specified once.

= **1...4**

The line numbers of your ports depend on the CC type. Further details can be found in the Release Notice.

[MAXIFL]

Maximum information frame length excluding the address and control field. With X.25 ports (UEWEG=X25/Typ...), the value of the MAXIFL operand must be greater than or equal to the value below:

4 plus the maximum of the PAKLE and PAKLS operands of all XFACI macros.

= **1...4096**

[MLNK]

The line is assigned to a multilink.

= **1...9**

[MODE]

This operand is used to specify vendor-specific protocol variants.

= **SIE**

= **IBM**

With IBM computer-to-computer connection, HDLC/UNB must be used. Only IBM is permitted for SDLC ports.

[MODTAKT]

Specifies whether the send pulse rate is supplied externally (e.g. by a modem) or is generated by the CC itself.

= **JA** (YES)

The pulse rate is supplied externally.

= **NEIN** (NO)

The pulse rate is supplied by the CC. This mode of operation is only relevant for direct connections via V.24 and is the default in this case.

[NRZI]

NRZI (non-return-to-zero-inverted) is a special signaling scheme that specifies how signals are coded on the line.

= **JA** (YES)

Specifies that data is to be transmitted by the NRZI method.

= **NEIN** (NO)

Specifies that data is to be transmitted by NRZ method. Only the value NEIN (NO) is permitted for X.25 links.

Default value for X.25 and frame relay ports: NEIN (NO)

Other connections: JA (YES)

[OPTIONS]

By specifying options, you can generate HDLC protocol variants. If you specify this operand in your KOGS source, only the specified options will be executed. This is preceded by an internal system check for illegal or missing information, based on IS 7776. If OPTIONS is not specified, the default values are used.

You can specify the options in the following combinations:

= **(2,8)**

For an X.25 interface.

= **([1],[2],[4],[7],[8],[10],[12],[13])**

For other ports.

Default values:

= (1,2,4,8)

For PLIDENT= *hexvalue*.

= (2,8)

For an X.25 interface.

= (2,4,8)

For other ports.

= (1,2,8,12,13)

Fixed operand value for PROFIL=SDLC.

The individual numbers are assigned the following options:

- 1 Identification (only if PLIDENT=*hexvalue*).
- 2 Sender provides prompt notification of sequence errors.
- 4 Data without sequence numbers.
- 7 Address field extension.
- 8 I-commands only.
- 10 Control field extension.
- 12 Test data link.
- 13 Request wait mode; only relevant for UNB/PRI and BAC.

OPTIONS for FR:

None or option 9 (default is "none"). Option 9 has the following meaning: "with the link management protocol LMI Rev.1"

[PKANALN]

Only permitted for a direct X.25 interface (XLTNG/UEWEG=X25/TYP...). This operand defines the range of logical channels to the X.25 network, which are to be reserved for PVCs.

If PKANALN is not specified, no channel is provided for PVCs.

= *a-z* $0 \leq a \leq z \leq 4095$



- The channel range is distributed by the network provider.
- The channel ranges are put in order and must not overlap (PKANALN < SKANANK < SKANALN < SKANABG). However, at least one of the operands must be specified.
- Only in a few networks can channel number 0 be used (e.g. TRANSPAC).
- The range of PVC numbers must be configured identically on both systems for DTE/DCE or DTE/DTE connections, but without channel number 0.
- The total number of all channels should not be greater than the released number of simultaneous transport connections.

[PLIDENT]

Processor line identification. You can use the PLIDENT operand to control the exchange of identification between directly connected systems that are linked via dial-up lines.

Systems exchange their identification once the connection is physically set up. PLIDENT specifies the identification of your own system. The values specified for the operand must be in agreement with those specified for PRIDENT in the corresponding XPRO call in the KOGS source file or the XPRO system.

This entry is not permitted for an X.25 line and SDLC link.

= NEIN (NO)

No exchange of identification occurs. This entry is the default for a dedicated line.

= *hexvalue*

If MODE=SIE , 24 bytes (even number of hexadecimal digits) are used as the identification to be exchanged; otherwise, up to 48 bytes may be used.

The OPTIONS operand must be set to 1 if specified. Otherwise, the value 1 is the default.

[POLLPAU]

Specifies a minimum time interval (or pause) before the next poll cycle is started. The specification of POLLPAU is only meaningful with XLTNG UEPROZ = HDLC/UNB and UEUNB=PRI/... (control station).§

= 0 No poll interval.

= 100...500...3600

After this interval in seconds, the control station starts the next poll cycle.

[PROFIL]

Specifies which transport layer incoming calls on this line are delivered. The partner-specific values can be set via the FSS (npid attribute of the FACIL object class).

= NEA

NEA protocol

= ISO

TP0/2 protocol

= NTP

No transport protocol

=PPP

Point-to-point protocol

= SDLC

SDLC must be specified for SDLC links and may only be specified for individual lines. A unique XSNID macro is required for each PROFIL=SDLC assignment. Note that UEWEG=X25/... is not permitted in combination with PROFIL=SDLC.

=- TCP/IP protocol

When data is transmitted via an X.25 network, the Call User Data is evaluated first; the PROFIL parameter is evaluated only if there are no specifications there or in the FSS.

For X.32 dialing (two-step dialing) the PROFIL operand is relevant in the second stage of setting up a connection for X.32 dialing. It defines the default transport protocol when setting up the incoming SVC if there is no CUD in the incoming call and no NPID in the FSS. This parameter applies to all the XZSTW KOGS macros associated with XLTNG.

[PRTIMER]

Protocol monitoring period for the HDLC system and station connections during the data phase. The CCP profile only evaluates the specification in units of 100ms. This means that the value 1 is stored in the configuration file when a protocol monitoring period of 150ms is specified.

= 100...60000

Value specified in milliseconds.

Default value for an X.25 port: 3000.

Otherwise: max. (3000, 24000*MAXIFL/UEGSW).

PRTIMER for FR and option 9: 5000, 10000, 15000, 20000, 25000, 30000 (interval of the heartbeat process for LMI in milliseconds.)

[PRTIM2]

Protocol monitoring period in the scaling phase (setup phase in HDLC).

= 100...3000

Value specified in milliseconds.

Default value for an X.25 port: 3000.

Default value for other ports: 500.

[PRTIM3]

PRTIM3 is used to set a partner monitoring mechanism. As with the PRTIMER operand, this operand is specified in milliseconds. PRTIM3 is relevant when:

- UEPROZ=HDLC/BAC
- UEPROZ=HDLC/UNB and UEUNB=SEC/...

If UEPROZ=HDLC/BAC, a so-called checkpointing timer is set. If no data is exchanged, an RR (receive ready) exchange is implemented under the control of this timer.

= 0...60000

Protocol monitoring period in milliseconds.

Recommended value: 6000...10000, min. twice as much as PRTIMER.

If UEPROZ=HDLC/UNB and UEUNB=SEC/..., no active partner monitoring takes place using RR. After the set period a check is simply made to determine whether the primary station (= the partner) is still polling.

= 0...65000...6000000

Partner monitoring period in milliseconds.

Recommended value: ≥ 1 minute

[RCB]

Number of retries for monitoring a “busy” condition of the remote data terminal equipment.

= 0...65535

The default value 0 means an unlimited number of retries.

[RUF]

Specifies how a dial-up connection is to be set up.

The entry RUF=DIREKT[/ABG] is mandatory for UEWEG=DATEX-L/V24.

=AUTO

The CCP detects an incoming call or accepts an outgoing connection request, sets up the connection, and monitors it.

=AUTO/ANK

The CCP detects an incoming call, sets up the connection, and monitors it. The CCP itself does not actively set up connections. Outgoing connection requests are rejected.

=AUTO/ABG

The CCP accepts an outgoing call, sets up the connection, and monitors it. Incoming calls are rejected.

=DIREKT

The "DIREKTRUF" special service is used. If there is data waiting to be sent, the switching center sets up the connection to a permanently cataloged user at the request of the CCP. The subsequent systems accept this incoming call. The CCP monitors the established connection. Incoming calls are handled in the same way as for AUTO.

=DIREKT/ABG

Like RUF=DIREKT, except that incoming calls are rejected.

=MANUELL

Manual dial-up by data telephone. Only relevant for switched telephone network with V.24. The entire procedure, from the issuing of the connection request through to the actual setup of the connection, must be completed within approximately 90 seconds. Once 90 seconds has elapsed, the connection request is rejected.

Incoming calls must be put through at the data telephone (data key). The application handles them like outgoing calls, i.e. the application must have an open connection request.

=MANUELL/ABG

Like RUF=MANUELL, except that incoming calls are rejected.

[RUFNUM]

Call number of the remote system with dial-up lines. This operand is mandatory for X.21 dial-up lines if a value other than DIREKT[/ABG] is set for the RUF operand in the XLTNG macro.

= *value*, '*value*', or "*value*"

Maximum of 24 dialing characters, including special characters predefined by the network provider.

Example

89,3/3

[RUFPAUS]

This operand defines the length of the waiting period between two call retries if an outgoing call was unsuccessful. Only permitted for a dial-up line.

= **6...120**

Value specified in seconds.

[RUFWDH]

Only relevant for dial-up lines.

This operand defines the number of call retries if an outgoing call was unsuccessful.

For DATEX-L lines, the number of call retries actually carried out also depends on the service signals in the network. In the case of multilinks, all lines belonging to a bundled group must be generated with the same value for RUFWDH.

= **0...3...7**

[SKANABG]

Only permitted for a direct X.25 interface (XLTNG/UEWEG=X25/TYP...).

In the case of a DTE, this operand defines a number range of logical X.25 channels which are used for SVCs and where only outgoing connections are possible. All incoming connection setup requests are rejected in order that these channels remain free for outgoing calls.

If SKANABG is not specified, no channel is provided exclusively for outgoing connections.

= *a-z* $1 \leq a \leq z \leq 4095$



You should note the following rules

- The channel range is distributed by the network provider.
- The channel ranges are put in order and must not overlap (PKANALN < SKANANK < SKANALN < SKANABG). However, at least one of the operands must be specified.
- In the case of a DTE/DCE connection, you must configure this number range as SKANABG on the partner system.

Caution: at the DCE system, the channels configured with SKANABG indicate **incoming** connections.

- In the case of a DTE/DTE connection, this operand only makes sense if only outgoing connections are to be configured.

Caution: at the partner system, this number range must be configured as SKANANK.

- The total number of all channels should not be greater than the released number of simultaneous transport connections.

[SKANALN]

Only permitted for a direct X.25 interface (XLING/UEWEG=X25/TYP...).

This operand defines the range of logical channels to the X.25 network which are used for SVCs and where both incoming and outgoing connections are possible.

If SKANALN is not specified, no channel is provided exclusively for incoming and outgoing connections.

= a-z $1 \leq a \leq z \leq 4095$



- The channel range is distributed by the network provider.
- The channel ranges are put in order and must not overlap (PKANALN < SKANANK < SKANALN < SKANABG). However, at least one of the operands must be specified.
- The range of numbers must be configured identically on both systems for DTE/DCE or DTE/DTE connections.
- The total number of all channels should not be greater than the released number of simultaneous transport connections.

[SKANANK]

Only permitted for a direct X.25 interface (XLTNG/UEWEG=X25/TYP...).

In the case of a DTE, this operand defines the range of logical X.25 channels which are used for SVCs and where only incoming connections are possible. All outgoing connection setup requests are rejected in order that these channels remain free for incoming calls.

If SKANANK is not specified, no channel is provided exclusively for incoming SVCs.

= a-z $1 \leq a \leq z \leq 4095$



- The channel range is distributed by the network provider.
- The channel ranges are put in order and must not overlap (PKANALN < SKANANK < SKANALN < SKANABG). However, at least one of the operands must be specified.
- In the case of a DTE/DCE connection, you must configure this number range as SKANANK on the partner system.

Caution: at the DCE system, the channels configured with SKANANK indicate **outgoing** connections.

- In the case of a DTE/DTE connection, this operand only makes sense if only incoming connections are to be configured.

Caution: at the partner system, this number range must be configured as SKANABG.

- The total number of all channels should not be greater than the released number of simultaneous transport connections.

[TPAUSE]

Specifies whether a pause of approx. 30 milliseconds should occur between two frames, during which time flags are sent. Such a pause is only required in special cases, where the partner system is having difficulties processing frames arriving at short intervals or with only one flag between them.

= **NEIN** (NO)

No pause between two frames.

= **JA** (YES)

30-millisecond pause between two frames.

[UEGSW]

Transmission speed on the line. The transmission speed must match the values set for the network or for the remote system. The appropriate transmission speed can be obtained from either your network provider or hardware engineer.

= **1200...9600...19200...115000**

For V24DEF. Value specified in bit/s.

When using a V.35/V.36 interface, the maximum transmission speed is 115000 bit/s.

= **1200...9600...19200, 48000, 64000, 128000, 256000, 512000, 1024000, 2048000**

For X21DEF. Value specified in bit/s.

[UEKONF]

This operand defines the transmission configuration of the HDLC connection.

= **PZP** Point-to-point connection.

= **MP** Multipoint connection. Only relevant for dedicated lines and UEPROZ=HDLC/UNB, UEUNB=SEC/...

[UEPROZ]

This operand defines the communication protocol of the ISO data link layer (layer 2).

The same protocol variant must be generated by the partner system.

= **HDLC/LAPB**

HDLC protocol variant LAPB. This is the default value and the only possible setting for an X.25 interface.

= **HDLC/UNB**

HDLC protocol variant Unbalanced.
Fixed operand value for PROFIL=SDLC

= **HDLC/BAC**

HDLC protocol variant Balanced. Otherwise, default value.

= **FR** Protocol variant for frame relay.

In the XSNID macro must be set: ADRTYP=FR-PVC and SUBNID=FR-i.

Default value for an X.25 interface: HDLC/LAPB

Otherwise: HDLC/BAC

[UEUNB]

This operand is only evaluated if UEPROZ=HDLC/UNB. It defines the function of the HDLC protocol in the local system.

= PRI/DX

The port is used as a primary station with a point-to-point connection. The operating mode is duplex. This value is not possible if the operand UEKONF=MP has been set in the XLTNG macro.

= PRI/HX

The port is used as a primary station with a point-to-point connection. The operating mode is half-duplex.

= SEC/DX

Secondary station in logical duplex mode.

= SEC/HX

Secondary station in logical half-duplex mode.

UEWEG

This operand defines the transmission path to the remote system or the X.25 variant to be used.

The defined transmission path must correspond with settings that you make with the XSNID macro.

If necessary the V24DEF operand may need to be specified.

If 2DR is specified, the RTS signal (with V.24) or the C signal (with X.21) is set before data is sent and subsequently reset. These signals are modem control signals. On the hardware level half-duplex mode is forced.

= DATEX-L[/X21]

Dial-up line with an X.21 interface, e.g. DATEX-L.

= DATEX-L[/V24]

Dial-up line with a V.24 interface for "DIREKTRUF".
The XLTNG/RUF operand must be set to DIREKT/[ABG].

= FE-WAHL/2DR

Dial-up network (telephone or X.21 port)

= FE-WAHL/4DR

Dial-up network (telephone or X.21 port)

= FE-STAND/2DR

Point-to-point connection (V.24, V.35, V.36 or X.21 port)

= FE-STAND/4DR

Point-to-point connection (V.24, V.35, V.36 or X.21 port)

= X25/TYP5

Network interface via a dedicated line. The interface runs with an X.25 protocol as defined in CCITT 1980. The local system is an end system (DTE). Note that the own DTE address is not to be entered in sent call packets, e.g. for an interface to TRANSPAC packet switching network in France.

= X25/TYP6

Network interface via a dedicated line. The interface runs with an X.25 protocol as defined in CCITT 1980. The local system is an end system (DTE), e.g. for an interface to DATEX-P/80 or to a X25/TYP56 X.25 system.

= X25/TYP8

Network interface via a dedicated line. The interface runs with an X.25 protocol as defined in CCITT 1984 or 1988. The local system is an end system (DTE), e.g. for an interface to DATEX-P/84 or to a X25/TYP58 X.25 system.

= X25/TYP9

Dedicated line which runs with an X.25 protocol as defined in ISO standard 8208. (The transmission path does not use the X.25 network.) It is negotiated with the communication partner, who acts as both DTE and DCE. For an interface to a X25/TYP9 X.25 system (DTE-DTE link).

= X25/TYP56

Dedicated line which runs with an X.25 protocol as defined in CCITT 1980. (The transmission path does not use the X.25 network.) The local system plays the part of a DCE. For an interface to a X25/TYP6 X.25 system (DTE-DCE link).

= X25/TYP58

Dedicated line which runs with an X.25 protocol as defined in CCITT 1984 or 1988. (The transmission path does not use the X.25 network.) The local system plays the part of a DCE. For an interface to a X25/TYP8 X.25 system (DTE-DCE link).

[VUEZEIT]

This operand defines the connection monitoring period for dial-up connections. Only relevant if the transport profile NEA is used, i.e. for WAN-NEA and WAN-NX25.

Specifies how long the connection is to be monitored between messages. If neither data nor control messages are registered during this monitoring period, the selected subnetwork connection is cleared.

= 0 No monitoring occurs.

= 1...24...127

Value specified in seconds.

The VUEZEIT should never be less than 24 seconds by default.

Recommended value:

```
VUEZEIT 2*( (transmission speed of line) +  
PRTIMER * (WDHZAEL+1) ).
```

The default value for PRTIMER is 3 seconds. The default value for WDHZAEL is 3.

The value for VUEZEIT should be high enough to ensure the transfer of at least one record (frame) by the HDLC, i.e. including possible retries in the HDLC **and** the transmission of an HDLC acknowledgment. For lower values, unnecessary retries for data are to be expected, which means that connections that are cleared as a result of VUEZEIT will need to be re-established. In the worst case scenario, the transport connection will be cleared, since the partner can no longer be reached.

[V24DEF]

This operand is mandatory for a line with a V.24, V.35 or V.36 interface.

= STD

[WDHZAEL]

Number of retries after unsuccessful polling/selecting and unsuccessful block transfer (with negative acknowledgments) in the HDLC protocol.

= 0...3...255

[X21DEF]

This operand can be specified for an X.21 port.

= DBP

11.3.4 XPRO - define link addresses and XID exchange

The XPRO macro defines remote systems. It is necessary if no X.25 protocol is used.

The following characteristics can be specified with XPRO:

- link address(es) for dedicated lines
- identification and call number of the remote system for dial-up connections

In the KOGS file, an XPRO macro appears behind the XLTNG macro that describes the subnetwork interface to the remote system.

In the case of dedicated lines, XPRO is recommended to specify the link address(es). Only one XPRO macro may be defined behind one XLTNG macro.

For switched connections, the XPRO entry is needed only if the XID string is to be checked. If there is to be no checking, you must not generate an XPRO macro which in turn means that every remote identification is accepted. The exchange of identification is switched on with the PLIDENT operand of the XLTNG macro.

[LINKADR]

This entry is recommended for dedicated lines to avoid the conflict of link addresses at the connection setup. This operand is irrelevant for dial-up connections.

It is used to specify the HDLC link addresses of your own and of the remote system. The link address of your system must match that of the remote system if you are using the Balanced procedure variant. The following example explains how to match the addresses:

Link address	System SR1	System SR2
Own link address	3	1
Link address of remote system	1	3

Table 64: Assignment of link addresses

SR1's own link address is the remote link address for system SR2, and vice versa. Therefore, when configuring a line for the remote system, you should assign exactly the opposite value of your own link address and remote link address.

= (1...3...254,1...254)

The first entry is your own link address, and the second is that of the remote system. This format is valid for the procedure variants HDLC/BAC and HDLC/LAPB.

= 1...222

Simple link address.

With HDLC/UNB, you must specify only one link address. In the case of PRI, this is the link address of the remote system; with SEC, it is your own link address.

[PRIDENT]

This entry is mandatory for dial-up lines. Without this entry checking the XID string will always produce a negative result. As soon as the XPRO macro is entered, the check is activated. The remote call number (RUFNUM) must also be generated in the XPRO macro.

PRIDENT specifies the identification of the remote system.

= *hexvalue*

If MODE=SIE, 24 bytes (even number of hexadecimal digits) are used as the remote identification; otherwise, up to 48 bytes are used.

[RUFNUM]

Call number of the remote system.

RUFNUM is required together with the PRIDENT operand if the remote system can be called or, for incoming calls, if the remote call number is known.

= *value*, '*value*' or "*value*"

Maximum of 24 characters, including special characters, assigned by the network provider.

Example

89,3/3

11.3.5 XSNID - define subnet ID

The XSNID macro defines a local subnetwork port.

A subnetwork is a self-contained unit of systems with uniform communication links.

A subnetwork port is the interface to a subnetwork. Every CC has one or more subnetwork ports.

A partner can be connected to different subnetworks simultaneously and can be contacted over each. A separate port is required for each subnetwork.

Every subnetwork port is defined by two attributes: the type of subnetwork and an unequivocal identification.

- The type of subnetwork can be a subnetwork with dedicated line(s) with or without an X.25 protocol or a subnetwork with dial-up line(s). You define the type of subnetwork with the ADRTYP operand.
- The unequivocal identification is made via the subnet identification number. You define the unequivocal identification with the SUBNID operand.

At the connection setup a certain procedure determines a route to the remote network address through the subnetwork. Exit point of the route is the local subnetwork port. Last point of the route is the subnetwork address of the remote system or the next intermediate system.

Routes with identical exit and last points need not be distinguished. Similarly, in this case different subnetwork ports need not be defined.

ADRTYP

This operand defines the type of subnetwork to which the subnetwork interface belongs.

The type of subnetwork that you define here must be consistent with the line definitions in the corresponding XLTNG macro(s).

= X21-ADR

For a call number in an X.21 dial-up network

= HDLCPP

For dedicated lines (HDLC, point-to-point, and multipoint)

= X25-ADR

For X.25 ports

= PT-ADR

For telephone networks

= FR-PVC

For frame relay networks

SUBNID

Identification of the local subnetwork access:

= X21-i, i=1...32

For X.21 subnetworks (e.g. DATEX-L)

= PP-i, i= 1...32

For dedicated lines

= X25-i, i=1...32

For X.25 subnetworks (e.g. DATEX-P)

= PT-i, i=1...32

For telephone networks

= FR-i, i=1...128

For frame relay networks

11.3.6 XSYSP - start KOGS

XSYSP is the first call in a KOGS source file. It is a mandatory macro.

The XSYSP macro has no operands.

11.3.7 XZSTW - define X.25 access with X.32 dialing

The XZSTW macro defines the X.25 attributes of a network change from a circuit-switched network to an X.25 network.

The XZSTW macro is only relevant for two-step dialing (X.32 dialing) and must hence be specified only in that case.

DTEADR

Own DTE main address, i.e. the DTE address of the interworking unit to the X.25 network. The German PTT also refers to the DTE address as the call number.

This entry is mandatory for two-step dialing.

= *decimal digit number*

Decimal number of up to 15 digits; assigned by the provider of the packet switching network.

If you have specified XFACI DTEADCA=TOANPI, you may enter DTE addresses of up to 17 decimal digits.

[FACIL]

Reference to an XFACI macro; specifies the name of the facilities and parameters for X.25 access. These facilities and parameters must be defined with the XFACI macro.

= *name*

Name that was specified in the FACIL operand of the XFACI macro.

Length: ≤ 7 characters

Characters: A...Z, 0...9, #, @, \$

First character: not equal to 0...9

[LPUFADR]

Specifies the identification of the line port, which must already be defined in the XLTNG macro. The referenced line must be in the same subnetwork. This operand is required to enable the selection of a line for network access in the case of grouped or bundled ports. The value specified here must be the same as the value specified for LPUFADR in the associated XLTNG macro.

= 1... 4

[NAME]

This operand is used to name the description of the X.25 access. This name must match the *x25-description* attribute of the FACIL object or of the SUBNET object in the FSS.

= *name*

Length: \leq 8 characters

Characters: A...Z, 0...9, #, @, \$

First character: not equal to 0...9

NETZTYP

This operand defines the X.25 variant to be used for two-step dialing.

= X25/TYP6

Network interface that runs with an X.25 protocol as defined in CCITT 1980. The local system is an end system (DTE), e.g. for two-step dialing to DATEX-P/80 or to a X25/TYP56 X.25 system.

= X25/TYP8

Network interface that runs with an X.25 protocol as defined in CCITT 1984 or 1988. The local system is an end system (DTE), e.g. for two-step dialing to DATEX-P/84 or to a X25/TYP58 X.25 system.

= X25/TYP9

Linkage with an X.25 system that runs with an X.25 protocol as defined in ISO standard 8208. (The transmission path does not use the X.25 network.) It is negotiated with the communication partner, who acts as both DTE and DCE. For two-step dialing to a X25/TYP9 X.25 system (DTE-DTE link).

= X25/TYP56

Linkage with an X.25 system that runs with an X.25 protocol as defined in CCITT 1980. (The transmission path does not use the X.25 network.) The local system plays the part of a DCE. For two-step dialing to a X25/TYP6 X.25 system (DTE-DCE link).

= X25/TYP58

Linkage with an X.25 system that runs with an X.25 protocol as defined in CCITT 1984 or 1988. (The transmission path does not use the X.25 network.) The local system plays the part of a DCE. For two-step dialing to a X25/TYP8 X.25 system (DTE-DCE link).

[RUFNUM]

Call number of the X.25 node to be dialed. Instead of RUFNUM, you can specify SNPAROUTES/facil and FACIL/x25-description in FSS (see also the NAME operand).

= *call number*

Maximum of 24 characters, including special characters, predefined by the network provider.

[SKANABG]

In the case of a DTE, this operand defines the range of logical X.25 channels which are used for SVCs and where only outgoing connections are possible. All incoming connection setup requests are rejected in order that these channels remain free for outgoing calls.

If SKANABG is not specified, no channel is provided exclusively for outgoing connections.

= *a-z* $1 \leq a \leq z \leq 4095$



- The channel range is distributed by the network provider.
- The channel ranges are put in order and must not overlap (SKANANK < SKANALN < SKANABG). However, at least one of the operands must be specified.
- In the case of a DTE/DCE connection, you must configure this number range as SKANABG on the partner system.

Caution: at the DCE system, the channels configured with SKANABG indicate **incoming** connections.

- In the case of a DTE/DTE connection, this operand only makes sense if only outgoing connections are to be configured.

Caution: at the partner system, this number range must be configured as SKANANK.

- The total number of all channels should not be greater than the released number of simultaneous transport connections.

[SKANALN]

This operand defines the range of logical channels to the X.25 network which are used for SVCs and where both incoming and outgoing connections are possible.

If SKANALN is not specified, no channel is provided exclusively for incoming and outgoing connections.

= a-z $1 \leq a \leq z \leq 4095$



- The channel range is distributed by the network provider.
- The channel ranges are put in order and must not overlap (PKANALN < SKANANK < SKANALN < SKANABG). However, at least one of the operands must be specified.
- The range of numbers must be configured identically on both systems for DTE/DCE or DTE/DTE connections.
- The total number of all channels should not be greater than the released number of simultaneous transport connections.

[SKANANK]

In the case of a DTE, this operand defines the range of logical X.25 channels which are used for SVCs and where only incoming connections are possible. All outgoing connection setup requests are rejected in order that these channels remain free for incoming calls.

If SKANANK is not specified, no channel is provided exclusively for incoming SVCs.

= a-z $1 \leq a \leq z \leq 4095$



- The channel range is distributed by the network provider.
- The channel ranges are put in order and must not overlap (PKANALN < SKANANK < SKANALN < SKANABG). However, at least one of the operands must be specified.
- In the case of a DTE/DCE connection, you must also configure this number range as SKANANK on the partner system.

Caution: at the DCE system, the channels configured with SKANANK indicate **outgoing** connections.



- In the case of a DTE/DTE connection, this operand only makes sense if only incoming connections are to be configured.

Caution: at the partner system, this number range must be configured as SKANABG.

- The total number of all channels should not be greater than the released number of simultaneous transport connections.

12 FSS configuration

The description of an FSS configuration is stored in a database called the Forwarding Support Information Base (FSB). The FSB is an object-oriented database. The FSS defines a series of object classes with their attributes. By making an entry in the FSB you create an object which belongs to a particular object class and to which you assign attribute values according to its object class.

For standard configurations you can make the required FSB entries via the character-oriented CMXCUI. Sample configurations can be found in chapters 4 to 10.

The *fssadm* command serves to configure the Forwarding Support Service (FSS) in expert mode. The command *fssadm* should only be used for special configurations and only by people with comprehensive knowledge of CMX and WAN.

FSS and the *fssadm* commands are described in detail in the “CMX, Operation and Administration” User Guide [1]. This chapter only deals with the parameters and values of object classes which are relevant for CCP-WAN.

Description format

The description format of the *fssadm* commands described below for the various object classes can be found in section “Notational conventions” on page 3 of this manual.

Actions

When you use the *fssadm* command, you apply specific actions to the object classes and their attributes. Refer to the description of the object class concerned to determine which actions are permitted for a specific object class.

The following actions can be specified in the *fssadm* command:

create

Creates an object with the specified attribute values.

delete

Deletes an object.

set

Sets the attributes of an object to the specified values.

FSS configuration

get Retrieves the objects of the specified object class together with their attributes.

If attribute values are specified, *fssadm* only selects objects with these attribute values. *fssadm* rejects specification of multiple attributes which each uniquely identify an object.

Examples of fssadm commands

```
fssadm create SNPAROUTES name=RX25_CS1 subnet=X25-1\  
          dteaddr=12345  
fssadm create NSAP name=NSIP_CS1 internet-addr=205.75.2.10\  
          snpa-list=RX25_CS1
```

Refer to the man pages for a detailed description of the *fssadm* command.

Uppercase and lowercase with actions, object classes and attributes

fssadm does not discriminate between uppercase and lowercase or between a dash (-) and underscore (_) when naming actions, object classes, attributes and attribute values which are symbolic constants.

Examples of using uppercase and lowercase with fssadm commands

The following three entries are permitted and have the same value:

```
subnet=ISDN-1 x25-1  
SubNet=isdn-1 x25-1  
SUBNET=ISDN_1 x25-1
```

Uppercase and lowercase with the name attribute

Uppercase and lowercase are discriminated for names which you have to define yourself (object class FACIL, SNPAROUTES, NSAP with the *name* attribute).

Examples of using uppercase and lowercase with the name attribute

The following three entries designate three different names:

```
name=HOST-1  
name=Host-1  
name=host_1
```

Uppercase and lowercase with fssadm information output

In the *fssadm* outputs, the names of actions and attributes are written in lowercase and the names of object classes and attribute values which are symbolic constants are written in uppercase.

Help functions

You can use the following commands to call help on the *fssadm* syntax:

fssadm_?

Displays a general description of the *fssadm* syntax and information on the help function.

fssadm_action_?

Displays the object class to which an action may be applied.

fssadm_action_object class_ [[attribute name=] attribute value ...]_?

Completes the command with the attributes which are suitable for the specified context. The context is thereby only taken into account for the attributes which follow the context in the output.

fssadm_action_object class_ [[attribute name=] attribute value ...]_attribute name= ?

Outputs the syntax of the specified attribute in the specified context. Only those attributes in the specified context are taken into account which precede the queried attribute.

Example

The `fssadm create snparoutes type=isdn-PVC?` command returns the following output:

```
fssadm create SNPAROUTES <name> [<subnet>] type=ISDN-NC\
      {<remsnpa> <pvc-nr> } (min=0,max=1)
      [<faci>]
```

The `fssadm create snparoutes subnet=x25-1 type=?` command returns the following output:

```
<type>: x[25] | P[VVC]
```

The special meaning of the question mark (?) for the shell must be noted when this is input. The character may have to be nullified with a backslash (\).

Abbreviated notation

Abbreviated keywords:

You can abbreviate the keywords as long as the commands, actions, object classes and attributes remain unique.

Example

```
fssadm create snparoutes name=XY subnet=x25 dte-addr=132345
```

Abbreviated notation:

```
fssadm cr sn nam=XY su=x25 dt=132345
```

Abbreviations with setting parameters:

Attribute keywords can be omitted as long as the values can be identified uniquely by their setting, format or context.

Example

```
fssadm create snparoutes name=XY subnet=x25-1 \  
type=x25 dte-addr=132345
```

Abbreviated notation:

```
fssadm cr sn XY x25-1 132345
```

Keyword and setting parameters can be combined as required.



Avoid abbreviations and the setting parameter notation in shell scripts which are to remain applicable over lengthy periods. Such commands may be rendered invalid if new object classes, attributes or attribute values are introduced in a product update.

12.1 FACIL object class

You can assign facilities to each route using a FACIL object. Parts of these facilities, such as those which are the same for several routes, can be grouped in an additional FACIL object, which you can then assign to the directly assigned FACIL object by means of the *facil* attribute. If a facility is defined both in the additional FACIL object and in the directly assigned object, the facility of the directly assigned FACIL object takes precedence.

If necessary, you can negotiate the facilities with the communication partner, and these facilities are then valid for the duration of the connection. Fixed, connection-specific facilities are defined using KOGS macros (XFACI and XLTNG) (see chapter “Configuration with KOGS macros” on page 223).

```
fssadm.create FACIL name=[_npid=]
  [_facil=][_compress=][_admit=][_ppp-profile=]
  [_x25-octet-string=][_x25-packet-size=][_x25-window-size=]
  [_x25-throughput=][_x25-cug=][_x25-cug-oa=][_x25-bcug=]
  [_x25-revch=][_x25-transit-delay=][_x25-fast-select=][_x25-rpoa=]
  [_x25-nui=][_x25-description=]
  [_fr-encaps=][_fr-cir=][_fr-cbs=][_fr-ebs=][_fr-prio=]
  [_fr-max--transit-delay=]
```

name=

Name of the FACIL object.

1-15 characters: letters, digits, and the special characters _ (underscore) and # (hash character).

A distinction is made between uppercase and lowercase. The first character must not be a digit or an underscore ‘_’.

npid=

Network protocol ID

N[EA]

NEA protocol

OSI-CO[NS]

TP0/2 protocol

I[INTERNET]

TCP-IP protocol

P[RIVATE]

Other protocols

facil=

Refers to a further FACIL object.

compress=

Specifies whether Van-Jacobsen header compression should be performed

T[CP/IP]

Compression is performed.

N[O]

Compression is not performed.

admit=

Desired access protection on the subnet level for TCP/IP via frame relay and X.25. *admit* is evaluated only when using CS-ROUTE.

B[OTH_IN_AND_OUT]

Incoming and outgoing calls are permitted.

O[UTGOING_ONLY]

Only outgoing calls are permitted.

I[NCOMING_ONLY]

Only incoming calls are permitted.

N[EITHER_IN_NOR_OUT]

Neither incoming nor outgoing calls are permitted.

ppp-profile=

Use of point-to-point protocol

N[O]

The point-to-point protocol is not used.

S[TANDARD]

The point-to-point protocol is used.

x25-octet-string=

DTE facilities according to CCITT X.25, Annex G (ISO8208)

1...109 octet in hex format

To improve clarity, the octet may be grouped using blanks and newline control characters; however, the entire expression must be enclosed within quotes (") in such cases.

x25-packet-size=

Packet size in send and receive direction in the form:

send direction/[receive direction]

Possible values for send and receive directions:

16, 32, 64, 128, 256, 512, 1024, 2048

If no value is specified for the receive direction, the value of the send direction is used as a default.

x25-window-size=

Window size. Number of unacknowledged data packets that can be sent to or received from the network in the form:

send direction/[receive direction]

Possible values for send and receive directions:

1-7 if XFACI PAKNUM=MOD8

1-127 if XFACI PAKNUM=MOD128

If no value is specified for the receive direction, the value of the send direction is used as a default.

x25-throughput=

Transfer speed in the send and receive directions in the form:

send direction/[receive direction]

Possible values for send and receive directions:

2,4 4,8 9,6 19,2 48 64

If no value is specified for the receive direction, the value of the send direction is used as a default.

x25-cug=

Selection of a closed X.25 user group

Possible values: 0...9999.

Leading zeros are evaluated: a single or 2-digit input stands for the "basic format", a 3 or 4-digit input for the "extended format".

x25-cug-oa=

Selection of a closed X.25 user group with an open outgoing call, i.e. an outgoing call can be used to reach members outside this group.

Possible values: 0...9999.

Leading zeros are evaluated: a single or 2-digit input stands for the “basic format”, a 3 or 4-digit input for the “extended format”.

x25-bcug=

Selection of a bilateral closed X.25 user group

A bilateral closed user group is a user group to which only two DTEs belong.

Possible values: 0...9999.

Leading zeros are not evaluated. The “extended format” must always be used.

x25-revch=

Request reversal of charges and/or accept request to reverse charges

B[OTH_REQ_AND_ACC]

Request reversal of charges, and accept request to reverse charges.

R[EQUEST_ONLY]

Request reversal of charges, but do not accept request to reverse charges.

A[CCEPT_ONLY]

Do not request reversal of charges, but accept request to reverse charges.

N[EITHER_REQ_NOR_ACC]

Do not request reversal of charges and do not accept request to reverse charges.

x25-transit-delay=

Desired transfer time in milliseconds

0-65534

x25-fast-select=

Set Fast Select transfer

The Fast Select facility allows data up to a maximum length of 128 bytes to be sent and received in the packets for connection management by using an extended Call User Data field.

If this attribute exists, Fast Select transfer is requested in the connection request packet.

N[O_RESTRICTION]

The partner may respond with a Call Accepted or Clear Request packet.

R[ESTRICTION]

The partner may only respond with a Clear Request packet.

x25-rpoa=

Selection of a route via one or more transit networks that are identified by their DNIC (Data Network Identification Code) in the form:

DNIC[+DNIC...] with a maximum of 12 elements

x25-nui=

Network User Identification

The Network User ID (NUI) is an identification issued by the network provider. This ID is entered in the Call Request Packet by the DTE during an outgoing X.25 connection setup.

Maximum 16 printable characters (ASCII or EBCDIC) or hexadecimal character pairs in the form:

formid:nui-value

formid

- A The NUI follows in ASCII format.
- E The NUI follows in EBCDIC format.
- X The NUI follows in hexadecimal format.

nui-value

A character string issued by the network provider

x25-description=

Refers to the predefined description of an X.25 access in an XZSTW macro in the configuration file.

The value must agree with the value of the NAME operand in the corresponding XZSTW macro.

The assignment to a route affects only outgoing calls. For incoming calls you assign the selection of a predefined description of the X.25 access to the corresponding subnet ID. See section "SUBNET object class" on page 287.

Possible values:

1..8 characters: letters, digits, and the special characters \$, # and @.

The first character must not be a digit. No distinction is made between uppercase and lowercase.

fr-encaps=

Protocol encapsulation as defined in RFC 1490

YES Encapsulation is used.

NO No encapsulation is used.

fr-cir=

Committed information rate in Kbit/s

0...2048

fr-cbs=

Committed burst size in Kbit. The value must be an integer and a multiple of the value of *fr-cir*.

0...2048

fr-eps=

Excess burst size in Kbit. The sum of the values for *fr-eps* and *fr-cbs* must not exceed 2048 Kbit.

0...2048

fr-prio=

Priority

1...3 (highest priority: 1)

fr-max-transit-delay=

Maximum transmission time in tenths of a second

1-65535

12.2 GNSAP object class

An GNSAP object represents a group of NEA computers with NEA addresses that match a specific pattern.

fssadm create GNSAP name= nea-addr-pattern= snpa-list=

name=

Name of the GNSAP object
1-32 printable and visible characters

nea-addr-pattern=

NEA address pattern

Possible values for the address pattern:

*/** All NEA computers

**/0...255*
All NEA computers of the specified region

snpa-list=

List of alternative routes (SNPAROUTES objects) that can be used to reach the NEA computers that belong to the group.

If the NEA computers are represented by multiple (GNSAP/NSAP) objects, the most specific entry is selected.

`snpa[/weight][+snpa[/weight]]...`

`snpa`

Name of an SNPAROUTES object

`weight`

Specifies a priority for the routes included in the list.

1...20

20 is the highest priority. The SNPAROUTES object specified with *snpa/20* in the list is used as the first alternative route.

To improve clarity, blanks and new-line control characters can appear before or after the "+" character. In this case, the entire expression must be enclosed in double quotes (").

Example

```
snpa-list="route1 + route2"
```

The list can have a maximum of 20 entries.

12.3 LOCNSAP object class

A LOCNSAP object is used to define the address of the own system.

A LOCNSAP object is created automatically on installing CMX. This object can be processed with the *fssadm set* command.

fssadm set LOCNSAP name= address

name=

Name of the LOCNSAP object

1-32 printable and visible characters

address

Address of the local system. At least one of the following parameters must be specified for *address*. The address to be entered will depend on the type of network that is used.

nea-addr=

NEA address in the form:

processor number/region number

Possible values for processor number and region number:

0...255

internet-addr=

Internet address in the form:

number.number.number.number

number

Decimal number from 0...255

An entry such as 0.0.0.0 is also sufficient.

osi-addr=

OSI address in Reference Publication Format according to IS 8348 Add2

12.4 NSAP object class

Each end system or intermediate system for which you want to establish transport connections is represented by an NSAP object.

fssadm create NSAP name= address [net=] snpa-list=

name=

Name of the NSAP object

1-32 printable and visible characters

address

Address of the end system or the intermediate system. At least one of the following parameters must be specified for *address*. The address to be entered will depend on the type of network that is used (see *net* parameter).

nea-addr=

NEA address in the form:

processor number/region number

Possible values for processor number and region number:

0...255

internet-addr=

Internet address in the form:

number.number.number.number

number

Decimal number from 0...255

osi-addr=

OSI address in Reference Publication Format according to IS 8348 Add2

net=

Type of network that is used from the local system to reach the NSAP. This entry is mandatory for OSI profiles.

N[EA]

NEA protocol

I[INTERNET]

TCP-IP protocol

OSI-CO[NS]**snpa-list=**

List of alternative routes (SNPAROUTES objects) that can be used to reach the NEA computers that belong to the group, in the form:

snpa[/weight][+snpa[/weight]]...

snpa

Name of an SNPAROUTES object

weight

Specifies a priority the routes included in the list.

1...20

20 is the highest priority. The SNPAROUTES object specified with *snpa/20* in the list is used as the first alternative route.

To improve clarity, blanks and new-line control characters can appear before or after the "+" character. In this case, the entire expression must be enclosed in double quotes (").

Example

```
snpa-list="route1 + route2"
```

The list can have a maximum of 20 entries.

12.5 SNPAROUTES object class

An SNPAROUTES object represents a group of equivalent routes. Equivalent routes have a common endpoint, i.e. the remote subnetwork port. In addition, the starting points of equivalent routes, i.e. the local subnetwork ports, have a common subnet ID.

A group of such equivalent routes is, in a simplified sense, also referred to as a route.

The parameters and parameter values relevant for CCP-WAN are described below.

fssadm create SNPAROUTES name= subnet= address[facil=]

name=

Name of the SNPAROUTES object

1-15 characters: letters, digits, and the special characters _ (underscore) and # (hash character).

A distinction is made between uppercase and lowercase. The first character must not be a digit or an underscore '_'.

subnet=

Subnet ID of the subnet ports that are part of this route (or group of routes). This value corresponds to the parameter value for SUBNID in the KOGS macro XSNID.

X25-n n=1...32

For X.25 subnet accesses (without X.32 switching)

X21-n n=1...32

For X.21 lines

PT-n n=1...32

For analog phone lines (including X.32 switching)

FR-n n=1...128

For frame relay subnet accesses

PP-n n=1...32

For point-to-point permanent connections (dedicated lines)

type=

Subnet address type

type needs to be specified only if the *line-nr* attribute is not used for a dedicated line (*type=PP*). In all other cases, the values for *type* are implicitly derived from the specification for the subnet address.

The following values are possible:

FR-PVC Frame relay PVC

PP Dedicated line

PT Analog telephone line

PVC X.25 PVC

X21 X.21 line

X21DIRECT

X.21 line with fixed partners

X25 X.25 switched line

X32-PTMSA

X.32 switching (X.25 access via analog telephone line)

address

Address of the remote subnetwork port. The values specified for *address* must be one, and only one, of the following parameters (except in the case of dedicated lines).

dial-nr=

X.21 call number of the partner system

1-24 printable characters, enclosed within single quotes (')

dial-nr=DIRECT/'own X.21 call number'

Own X.21 call number

1-24 printable characters, enclosed within single quotes (')

phone-nr=

Phone number of the partner system. *phone-nr* is evaluated only if AUTO/ABG or AUTO/ANK for the parameter RUF AUTO in the KOGS macro XLTNG. In the case of other values for RUF, you must specify a dummy phone number.

1-24 printable characters, enclosed within single quotes (')

line-nr=

CC and line number for a dedicated line in the form:
[CC number/]line number

CC number

Number of the CC: 1...256

line number

Single-digit line number: 1...4

The *line-nr* attribute is optional.

dte-addr=

Remote X.25 DTE address

1-17 decimal digits

pvc-nr=

X.25 PVC number and, optionally, the associated local DTE
address in the form:

PVC number[/DTE address]

Possible value for PVC number: 0...4095

Possible value for DTE address: 1-17 decimal digits

fr-pvc=

CC number, line number and frame relay PVC number in the form:
CC number/line number/frame relay PVC number

CC number

A specified value *n* corresponds to the TNS entry WAN *n*.

Possible value: 1...256

Line number

Corresponds to the decimal value of the KOGS parameter
LPUFADR.

Possible value: 1...4

Frame relay PVC number

Possible value: 16...1007

x32-phone-nr=

For X.25 access via the analog phone network (X.32 dialing):
phone number and remote X.25 DTE address in the form:

phone number/DTE address

Phone number: 1-24 printable characters, enclosed within single quotes ('')

DTE address: 1-17 decimal digits

facil=

References a FACIL object

12.6 SUBNET object class

Objects of the SUBNET class represent a local subnet connection, which is uniquely identified by a subnet ID, or a group of local subnet connections, which is identified by the subnet ID that is common to these connections (subnet attribute).

The object is assigned values which are required to set X.32 two-step dialing and to activate and deactivate access control.

fssadm_create SUBNET

```
..subnet=[..incoming-call=][..x25-description=]
[..osi-nsap-address=]
```

subnet=

Subnet ID

X25-1...32

Subnet ID of the X.25 access

PT-1...32

Subnet ID of the telephone access

X21-1...32

Subnet ID of the interface for an X.21 switching network

[incoming-call=]

Together with the *admit* attribute, this attribute provides the configuration function for access control in CCP-WAN. It acts as a switch for activating and deactivating access checks (temporarily or permanently).

Only relevant to switched connections.

NONE

The subnet address test is deactivated. All incoming connection requests are rejected. Any *admit* attribute configured for the calling address is ignored.

RESTRICTED

Access control on the basis of the subnet address is activated. Incoming connection requests are accepted only if an incoming call is configured as permissible for the calling address, i.e. if the corresponding SNPAROUTES or REMSNPA object is assigned a FACIL object which has the attribute *admit=BOTH_IN_AND_OUT* or *admit=INCOMING_ONLY*.

Only relevant for X.25 SVCs and X.21 switched connections.

ALL

Access control is inactive. All incoming connection requests are processed. Any *admit* attribute configured for the calling address is ignored.

If there is no *incoming-call* attribute, the *admit* attribute is evaluated only by CS-ROUTE.

[x25-description=]

The *x25-description* attribute is permitted only for PT subnet IDs.

It refers to the predefined description of the X.25 access in a XZSTW macro in the configuration file.

This attribute selects the specified description of the X.25 access for telephone calls if appropriate.

The value must match the value of the *NAME* operand in the corresponding XZSTW macro.

Possible values:

1...8 characters: letters, digits, characters \$, # and @.

The first character must not be a digit. No distinction is made between upper and lower case.

[osi-nsap-address=]

OSI address in Reference Publication Format in accordance with IS 8348 Add2

This attribute is only permitted for objects with subnet ID X25-n ($n = 1, 2, \dots, 32$) and can only be specified with the *fssadm* commands *create*, *get* and *set* .

Any syntactically correct OSI-NSAP address is accepted.

The address does not have to be unique: the same OSI-NSAP address may occur for different SUBNET objects and/or NSAP objects and/or the LOCNSAP object.

13 Administration and diagnostics

This chapter describes the administration and diagnosis commands and the help functions for working with network access software and the Communication Controllers (CC).

Some of the administration and maintenance commands for network access software and CCs must be performed in expert mode. The following steps are required for this purpose (see also the “CMX, Operation and Administration” User Guide [1]):

1. Select *Communication Controller* in the CMX menu.
2. Select the Communications Controller you want to administer.
3. Select the CC operation *Enter expert mode*.

You should now be in expert mode, as is evident from the displayed user interface prompt, which consists of the relevant Communications Controller identification and an asterisk (*), e.g. *WI**. You may enter any administration command in expert mode.

The response from the CCP is time-monitored for commands that await an answer. An error message is output if the response does not arrive in time.

If you want to exit expert mode and return to the starting menu, press the **End** key or the **CTRL** **D** combination.

The command line interface (CLI) remains available at operating system level.

Command overview

The following is a list of all commands that can be called either using the CMX menu or from the CLI. The commands are sorted by function group:

Function group	Command	Description
Administration commands: Configuration check and modification	ach	Activate line
	assign	Assign network access software to Communications Controller
	cronstart	Activate "automatic reload"
	cronstop	Deactivate "automatic reload"
	ista	Display line status
	table	Display all profiles and controllers supported by the board status administration
	compile	Compile configuration source file
	list	List configuration files and configuration source files
	dah	Deactivate line
	exchange	Exchange configuration file
	info	Query CC status information
	linkstat	Query status of CC links
	load	Load network access software
	stop	Stop network access software
Diagnostic commands: Trace list handling	dump	Create dump of CC memory
	format	Edit trace lists and dumps
	sof	Switch off trace
	son	Switch on trace
	tof	Switch off trace transfer
	ton	Switch on trace transfer
	trigger	Switch on trace list in response to events

Table 65: Overview of commands by function group

Function group	Command	Description
Help functions	cmdfile	Execute command file
	:	Change administered CC
	?	List diagnostic commands
	!	Execute shell command
	#	Enter comment in command file

Table 65: Overview of commands by function group

Command syntax

Commands have the following syntax:

command[_-b_cc][...]

command

Name of the command

Options

An option consists of a hyphen, a selector, and an argument. For the purposes of this manual, hyphens and selectors are printed in bold.

The blank between the selector and the argument may be omitted.

Options may be specified in any order, and arguments may be entered in either uppercase or lowercase.

-b_cc

Specifies the ID of the Communications Controller, and thus enables you to change the administered CC. This option appears in almost all commands and is therefore only explained here once for all commands.

cc

Designation *W1*, *W2*, ... *W6* of the CC.

-b_cc not specified:

The CC that you selected when invoking diagnostic mode is preset. If you call this command via the CLI, the *-b* option is normally required.

[...]

Entry of additional options.

Sample administration command

There are two ways of changing the CC being administered:

- Command : (colon)

You are administering the CC *W1*, for example, and want to switch to the CC *W3*.

```
W1* : -b W3
W3*
.
.
```

- Command with the designation of the desired CC

Specify the command with *-b_cc*.

You are administering the CC *W2*, for example, and want information on the CC *W3*.

```
W2* info -b W3
...
W2*
.
.
.
```

13.1 Administration commands

A description of all of the administration commands, arranged in alphabetical order, is provided below.

13.1.1 ach - Activate line

The *ach* command is used to activate a line configured in the KOGS source on a loaded Communications Controller. This means that the software resources are made available, and the local hardware is checked, e.g. to ensure that the line is physically connected, that the modem returns a pulse, and that the X.21 circuit switching network is ready, etc.

ach **-b** **_cc** **-l** **_n**

-b **_cc**

Designation of the CC.

-l **_n** Designation of the line number.

n Line number that corresponds to the LPUFADR parameter in the XLTNG macro of the KOGS configuration file.
In this case, $n = 1 \dots 4$ (default value:1).

Note that line numbers are specified in hexadecimal notation in the KOGS configuration file, but in decimal notation for administration commands.

Instead of this command, you could also select *NetIf - Local Subnet Interfaces...* in the CMX main menu and (after choosing a CC) under the *Operations for Subnet Interfaces* menu the *Activate Subnet Interface* operation.

13.1.2 assign - Assign network access software to a CC

The *assign* command is used to assign network access software to a CC. This assignment will only take effect the next time the CC is loaded.

assign **-b** **cc** **-c** **ccp**

-b **cc** Designation of the CC.

-c **ccp** Specifies the network access to be assigned to the CC.

ccp Name of the network access software: WAN.

If the minus sign (-) is specified instead of a name, the current assignment is deleted.

Instead of this command, you could also select *CCs - Communications Controller* in the CMX main menu and (after choosing a CC) under the *Operations for CC* menu the *Change Configuration* operation.

Example

You are administering the CC *W1*. You want to assign the WAN to the CC *W2*.

```
W1* assign -c WAN -bW2
W1*
```

or

```
W1* : -b W2
W2* assign -c WAN
W2*
```

13.1.3 compile - Compile configuration source file

The *compile* command can be used to call a compiler that compiles the configuration source file for the network access software and Communications Controller.

compile *-b* *cc* *-c* *ccp* *-f* *file*

b *cc*

Specifies the ID of the Communications Controller.

-c *ccp*

Specifies the network access to be assigned to the CC.

ccp

Name of the network access: WAN

-f *file*

Specifies the name of the configuration source file that is to be assigned to the network access and compiled.

file

File name with a maximum length of 10 characters.

13.1.4 cronstart - Activate “automatic reload”

If the CMX cronjob is active, you use the *cronstart* command to activate the automatic reloading of a controller after a failure.

cronstart *-b* *cc*

13.1.5 cronstop - Deactivate “automatic reload”

The *cronstop* command is used to deactivate the automatic reloading of a controller.

cronstop *-b* *cc*

13.1.6 dah - Deactivate line

The *dah* command is used to deactivate a physical line to the subnetwork on a CC.

dah *-b* *cc* *-l* *n*

-b *cc* Designation of the CC.

-l *n* Designation of the line number.

n Line number that corresponds to the LPUFADR parameter in the XLTNG macro of the KOGS configuration file.

In this case, $n = 1 \dots 4$.

Note that line numbers are specified in hexadecimal notation in the KOGS configuration file, but in decimal notation for administration commands.

Instead of this command, you could also select *NetIf - Local Subnet Interfaces...* in the CMX main menu and (after choosing a CC) perform the *Deactivate Subnet Interface* operation under the *Operations for Subnet Interfaces* menu.

13.1.7 exchange - Exchange configuration file

The *exchange* command is used to exchange or assign the configuration file (CF) for the network access software of the specified Communications Controller.

exchange **-b** *cc* **-c** *ccp* **-k** *file*

-b *cc* Specifies the ID of the CC for which you want to exchange the CF.

-c *ccp* Profile for which the CF is exchanged. A configuration file can also be exchanged for a profile other than the one currently assigned.

If the minus sign is specified instead of a name, the current assignment is deleted.

ccp Name of the network access: WAN

-k *file* Name of the configuration file to be assigned to the CC or network access.

file Name of the CF. The file name can be up to ten characters in length.

The system appends the suffix *.ccp* to the name. The CF must be first created by compiling a configuration source file. If a minus sign is specified instead of a name, the current assignment is deleted.

Instead of this command, you could also select *CCs - Communications Controller* in the CMX main menu and (after choosing a CC) under the *Operations for CC* menu the *Change Configuration* operation.

13.1.8 info - Query CC status information

The *info* command is used to query the CC configuration and the status of the loaded network access. The output is displayed on the screen.

info[_-b_cc]

-b_cc Designation of the CC for which information is to be displayed.

-b_cc cc not specified:
Information is output for all CCs.

Output of the info command:

The information is output in the following format:

CC Status	CCP profile loaded	CF loaded	CCP profile assigned	CF assigned
W1 READY	WAN	w1_wan.ccp	WAN	w2_wan.ccp

The loaded configuration file (w1_wan.ccp) is currently in effect. The assigned configuration file (w2_wan.ccp), by contrast, will take effect only on reloading the CC.

13.1.9 linkstat - Display status of the CC connections

The *linkstat* command is used to display the status of the CC connections. The output is displayed on the screen.

linkstat[**-b** *cc*][**-l**][**-h**][**-v**]

- b** *cc* Designation of the CC for which information is to be displayed.
 - b** *cc* not specified:
Information on all CCs is displayed.
- l** Specifies that a detailed list should be output.
- h** Specifies that no header should be output.
- v** Outputs information in unencoded form about the abbreviations used in the linkstat output (verbose).

Output of the linkstat command

The information is output in the following format:

CC	IF#	STATE	TYPE	Bits/s	LINK	LINKS	NETW.	SUBNET	SUBNET- ID	SUBNET- ADDR
W1	1	BUSY	X.21	64k	BAC	1/1	----	CSDN	PT-1	87654
W1	2	DISA	V.24	2400	BAC	0/1	----	PHONE	PT-2	4321
W1	3	----	X.21	----	---	---	----	----		----
W1	4	----	X.21	----	---	---	----	----		----

The individual columns are described below:

CC Communications Controller ID

IF# Connection number

STATE

Status of the connection

Connection not configured

DISA

Connection disabled

LINK

Links are set up

BUSY

Maximum number of connections reached

HWEN

Hardware is ready for operation

NETC

Connection setup to network or node (e.g. dialing)

TYPE

Physical connection type: X.21 or V.24

Bits/s

Transmission rate

LINK

Used transfer protocol (layer 2)

LINKS

Number of connections in the form:

existing connections / maximum number of connections

NETW.

Type of network protocol used: X.25 or T.70-3

SUBNET

The physical connection is used as:

----- Unknown

CSDN Circuit Switched Digital Network

X.21 dial-up connection

PHONE Dial-up connection via telephone

V.24 connection

LEASED Dedicated line (X.21, V.24, V.35 or V.36)

Frame relay via dedicated line

MP Multipoint dedicated line

SUBNET-ID

As specified in the XSNID macro of the KOGS source

SUBNET-ADDR

Specifies the subnetwork address; for switched connections, the own telephone number

13.1.10 load - Load network access software

The *load* command is used to load network access software and its corresponding configuration file (CF) on a CC. The execution of a shell script is started with this command; *load* must not be called using a command file.

The command loads the network access software that you previously assigned to the selected CC. The CF that was exchanged for the currently assigned network access software and CC is effective here.

load[_b_cc]

-b_cc Designation of the CC.

Instead of this command, you could also select *CCs - Communications Controller* in the CMX main menu and (after choosing a CC) under the *Operations for CC* menu the *Load CC* operation.



If network access software is active on the specified CC when the load command is called, this software is stopped without warning, and the currently assigned network access software is loaded.

13.1.11 list - List configuration files

The *list* command is used to display the existing configuration source files and configuration files.

list[_b_cc]-c_ccp

-b_cc

-c_ccp

Profile for which the configuration files are to be displayed.

ccp name of the network access software: WAN

13.1.12 stop - Deactivate network access software

The *stop* command is used to deactivate loaded network access software and thus also the loaded Communications Controller.

stop *-b* *_cc*

-b *_cc* Designation of the CC.

Instead of this command, you could also select *CCs - Communications Controller* in the CMX main menu and (after choosing a CC) under the *Operations for CC* menu the *Unload CC* operation.



Any existing connections via this CC are cleared down. Before entering the *stop* command, you should therefore ensure that there are no further connections via this CC.

13.2 Diagnostics commands

13.2.1 dump - Dump CC memory

The *dump* command is used to write the current contents of the CC memory (program and data) into a file. This file contains important information for the analysis of errors. You can convert this file with the *format* command (see page 303). Following the dump, the network access software must be reloaded on the Communications Controller.

dump **-b** **cc** [**-f** **file**]

-b **cc** Designation of the CC.

13.2.2 format - Edit trace lists and dumps

The *format* command is used to convert both the trace lists and dumps from binary files into readable form.

Editing trace lists

The trace lists must be created previously using *son*, *ton* and *tof*.

Editing dumps

You must first create the CC memory dump in a file (see command *dump* on page 303).

format **-b** **cc** [**-c** **ccp**] **-t** **list** [**-f** **file1**] [**-g** **file2**]

-b **cc** Designation of the CC.

-c **ccp** Name of the network access software from which the trace list or dump was created.

ccp Name of the network access software:WAN

-t **list** Specifies the trace lists or the dump. If you wish to specify multiple trace lists, you must separate the individual entries with blanks and enclose the entire specification within quotes, e.g. **-t** "IN_IP".

list Designation of the trace list or dump in accordance with the following table.

Designation	Meaning
IN	NPI specification of profile, TSP and addresses
IP	Interface signals of layer 3 (e.g. X.25)
LI	Interface signals of layer 2
LP	HDLC and modem signalling
SN	Multilink trace
LM	Layer manager of layer 2
LN	Signals of the line components
AL	ADM list of LMDEs
HP	Bus interface controller / host
ER	Error notification list
SX	X.25 statistics
LA	Line statistics
LV	Resource statistics
SL	Sorted list
DU	Dump

Table 66: Designations of trace lists and dumps for the *format* command

-f_file1 Specifies the file containing the dump or trace list.

If you specify *-f_file1*, you can only enter one designation in the *-t_list* option.

file1 Name of the file to which the trace list or dump was written (see the *file* argument of the *dump* or *ton* command). A system file called *file1_0.bin* and/or *file1_1.bin* is required to edit a trace list. The name of *file1* can be up to eight characters long.

-f_file1 not specified:

The default file names are listed in the following table:

Lists	Default file names
Trace lists	cc_list_0.bin cc_list_1.bin
Dump lists	cc_DU.bin

Table 67: Default file names for *format*

-g_file2 Specifies the file to which the edited trace lists or dump are to be written.

file2 Name of the file. The file name can comprise up to ten printable characters. The system appends the suffix *.txt* to the name.

-g_file2 not specified:

The file name is derived from the name of the file to be edited, *file1*, by appending the suffix *.txt* instead of the suffix *.bin*.

Example

You want to create and edit a layer 2 trace list (LP list) for the CC *W1*.

Before starting the test:

Switch on the LP trace list:

```
W1* son -t LP
```

Switch on list transfer for the LP trace list:

```
W1* ton -t LP
```

After completing the test:

Switch off the LP trace list:

```
W1* sof -t LP
```

Transfer the rest of the list by switching off list transfer:

```
W1* tof -t LP
```

Edit the transferred trace list:

```
W1* format -t LP
```

The results are stored in the file:

```
/opt/SMAW/SMAWcmx/lib/ccp/diagfiles/W1_LP.txt.
```

13.2.3 sof - Switch off trace list

The *sof* command is used to switch off trace lists and trace points.

sof **-b** *cc* **-t** *list* [**-i** *id*] [**-l** *line*]

-b *cc* Designation of the CC.

-t *list*

Specifies the trace lists. The individual lists must be separated by blanks and the entire specification enclosed within quotes,

e.g.: -t "IN_LI".

list Designation of the trace list in accordance with the following table.

Designation	Meaning
IN	NPI specification of profile, TSP and addresses
IP	Interface signals of layer 3 (e.g. X.25)
LI	Interface signals of layer 2
LP	HDLC and modem signalling
SN	Multilink trace
LM	Layer manager of layer 2
LN	Signals of the line components
AL	ADM list of LMDEs
HP	Bus interface controller / host

Table 68: Designations of trace lists for *sof*

-i *id* Specifies the trace points to be switched off in a specific trace list. If you want to specify two or more trace points, you should enclose the designations (separated by blanks) in quotation marks, e.g. -i "LH_LD".

id The designations for trace points are shown in the following table:

Trace lists	Designation	Trace points/Meaning
LI trace list Default: LC + LB + LY	LC LB LY	ILINK-P trace ILINK-E trace IPHYS line trace
LP trace list Default: LH + LV + LD	LH LV LD LX	HDLC protocol trace Connection Handler protocol trace Data trace Extended data trace
AL trace list Default: ID + IM	ID IM	ILMDE trace ILME trace
HP trace list Default: AD + DI + DO	AD DI DO	Administration interface trace ITRANS-IN data trace ITRANS-OUT data trace

Table 69: Designation of trace points for *sof*

-i_id not specified:

The trace list specified with *list* is switched off.

-l_line :

Number of the line for which the trace is to be switched off.

13.2.4 son - Switch on trace list

The *son* command is used to switch on trace lists and trace points.

son[*-b_cc*]*[-t_list*[*-i_id*] [*-l_line*]

-b_cc Designation of the CC.

-t_list Specifies the trace lists. The individual lists must be separated by blanks, and the entire specification must be enclosed within quotes,

e.g.: *-t "IN_IP"*.

list The designations for trace lists are shown in the following table.

Designation	Meaning
IN	NPI specification of profile, TSP and addresses
IP	Interface signals of layer 3 (e.g. X.25)
LI	Interface signals of layer 2
LP	HDLC and modem signalling
SN	Multilink trace
LM	Layer manager of layer 2
LN	Signals of the line components
AL	ADM list of LMDEs
HP	Bus interface controller / host

Table 70: Designations of trace lists for *son*

-i_id Specifies the trace points to be switched on in the trace list. If you wish to specify two or more trace lists, you should enclose the designations (separated by blanks) in quotation marks, e.g. *-i "LC_LB"*.

id The designations used for trace points are shown in the following table:

Trace lists	Designation	Trace points/Meaning
LI trace list Default: LC + LB + LY	LC LB LY	ILINK-P trace ILINK-E trace IPHYS line trace
LP trace list Default: LH + LV + LD	LH LV LD LX	HDLC protocol trace Connection Handler protocol trace Data trace Extended data trace
AL trace list Default: ID + IM	ID IM	ILMDE trace ILME trace
HP trace list Default: AD + DI + DO	AD DI DO	Administration interface trace ITRANS-IN data trace ITRANS-OUT data trace

Table 71: Designations of trace points for *son*

-i_id not specified:

The default trace points are switched on for the trace lists specified with *list*.

-l_line :

Number of the line for which the trace is to be switched on.

13.2.5 tof - Switch off trace list transfer

The *tof* command is used to switch off the transfer of trace lists from the CC to files. After you enter the *tof* command, any incomplete partial lists are transferred from the CC. The transfer is then switched off. The trace lists can be converted with the *format* command. (see format on page 303).

tof_-b_cc_-t_list

-b_cc Designation of the CC.

-t_list Specifies the trace lists. The individual lists must be separated by blanks, and the entire specification must be enclosed within quotes,

e.g.: -t "IN LI".

list The designations for trace lists are shown in the following table.

Designation	Meaning
IN	NPI specification of profile, TSP and addresses
IP	Interface signals of layer 3 (e.g. X.25)
LI	Interface signals of layer 2
LP	HDLC and modem signalling
SN	Multilink trace
LM	Layer manager of layer 2
LN	Signals of the line components
AL	ADM list of LMDEs
HP	Bus interface controller / host
ER	Error notification list
SX	X.25 statistics
LA	Line statistics
LV	Resource statistics

Table 72: Designations of trace lists for *tof*

13.2.6 ton - Switch on trace list transfer

The *ton* command is used to switch on trace list transfer from the CC to files. In all cases, there are two files that are cyclically overwritten.

ton **-b** *cc* **-t** *list* [**-z** *time*] [**-f** *file*] [**-l** *length*]

-b *cc*

Designation of the CC.

-t *list*

Specifies the trace list(s) to be switched on. The individual entries must be separated by blanks, and the entire specification must be enclosed within quotes, e.g.: -t "IN LI".

list

The designations for trace lists are shown in the following table.

Designation	Meaning
IN	NPI specification of profile, TSP and addresses
IP	Interface signals of layer 3 (e.g. X.25)
LI	Interface signals of layer 2
LP	HDLC and modem signalling
SN	Multilink trace
LM	Layer manager of layer 2
LN	Signals of the line components
AL	ADM list of LMDEs
HP	Bus interface controller / host
ER	Error notification list
SX	X.25 statistics
LA	Line statistics
LV	Resource statistics
SL	Sorted list

Table 73: Designations of trace lists for *ton*

-z_time

Specifies the time interval for list transfer.

time Time interval for list transfer.

1...64800 seconds.

Once this interval has elapsed, the list is transferred automatically.

-z_time not specified:

Partial lists are transferred once they are full.

-f_file

Specifies the file to which the requested lists are to be written. The file is created or overwritten in the */opt/SMAW/SMAWcmx/lib/ccp/diagfiles* directory.

file Name of the file. The file name may consist of up to eight printable characters. Only one trace list can be specified.

There are two files in each case, which are written cyclically and alternately. The extension *_nr.bin* is created internally by the system, where *nr* (*nr* = 0, 1) identifies the two trace files that are written cyclically.

-f_file not specified:

The trace list is transferred to the files with the default names *cc_list_0.bin* and *cc_list_1.bin*. The files are created or overwritten in the */opt/SMAW/SMAWcmx/lib/ccp/diagfiles* directory.

-l_length:

Maximum length of the trace lists in bytes (default: 50 000bytes)

13.3 Help functions

The Help functions simplify the handling of command files.

13.3.1 cmdfile - Execute command file

The *cmdfile* command is used to execute a command file.

cmdfile[*_-b_cc*]*_-f_path*

-b_cc Designation of the CC.

-f_path

Designation of the command file

path Path name of the command file containing the command lines. A command line can have up to 240 printable characters.

Example

Command:

```
cmdfile -f /usr/admin/lplist
```

A command file could look as follows:

```
# Switch on predefined trace points of LP trace list:  
son -t LP  
# Switch on list transfer for LP trace list:  
ton -t LP
```

13.3.2 : Change administered CC

The Help function : (colon) allows you to change the administered CC.

:_-b_cc

-b_cc Designation of the CC you want to administer.

13.3.3 ? List diagnostic commands

The Help function ? (question mark) outputs information on the screen concerning the commands available in diagnostic mode.

?[_f_fct]

-f_fct Designation of the function.

fct Name of the function. The syntax of the specified command is output with all options and operands.

-f_fct not specified:
All commands are listed.

13.3.4 ! Execute shell command

The Help function ! (exclamation mark), followed by a command, is used to execute shell commands.

!_comm

comm
Specifies a shell command line.

Example

- You are in diagnostic mode of the CC *W2* and want to display the diagnostic file *NEWSFILE*.

```
W2* ! cat /opt/SAW/SAWcmx/lib/ccp/diagfiles/W2_NEWSFILE_1
```

 After the diagnostic file has been output, you are returned to diagnostic mode.
- You are in diagnostic mode of the CC *W1* and want to switch to a subshell.

```
W1* ! sh
```

13.3.5 # Enter comment in the command file

The Help function #_ (number sign followed by a blank) is used to introduce comment lines in a command file. Any lines in the command file that begin with this sign are identified as comment lines and are ignored.

#_[comment]

comment

Any character string.

14 Administration and diagnostic commands for the Transport Service Providers (TSPs)

This chapter gives information on the administration of the Transport Service Providers (TSPs). The Transport Service Providers use transport protocols to make network transport services available. The product, CCP-OSI/NEA, makes the NEA and TP02 TSPs available. The NTP TSP is a component of CMX.

This chapter provides instructions for diagnosing errors and also instructions on what to do if you want to customize your configuration. You will find full descriptions of the commands and files mentioned in this section in the man pages.

Commands for the TSPs are entered at the operating system level.

14.1 Operational readiness of the Transport Service Providers

Normally, when CMX or CCP/OSI-NEA have been installed and the system is started, the installed TSPs will start automatically. When started successfully, the TSPs are **ready for operation**. The TSPs will then enter the READY state, i.e. they can now be used for data communication. In the following example, the NEA-TSP is ready for operation:

```
#nea
Control Command NEA TSP (SMAWnea 6.0A00) Tue May 13 13:56:17
CEST 2003
```

```
State of the NEA TSP:  READY.
NEA daemon nead:      running,  PID=4544.
NEA TSP autostart is:  enabled.
Periodical check
of the NEA daemon is:  enabled.
Local Nsap (proc/reg) 2/18
```

A TSP may fail to start if the resources or required configuration information for starting are not available. For example, the NEA-TSP fetches its local NSAP from the current configuration database. If no local NEA-NSAP is configured, NEA-TSP will not be ready for operation.

A TSP can be interrogated for its current state using the command, *cmxinfo* and the individual commands for each TSP, *nea*, *ntp* and *tp02*.

The state of a TSP that is installed but not ready will be shown as EXIST:

```
#nea
Control Command NEA TSP (SMAWnea 6.0A00) Tue May 13 14:02:32
CEST 2003

    State of the NEA TSP:  EXIST.
    NEA daemon nead:      not running.
    NEA TSP autostart is:  enabled.
    Periodical check
    of the NEA daemon is:  disabled.
```

Additional diagnostic information can be obtained by using the *diag* variant of the TSP commands *nea*, *ntp* and *tp02*. The last entry in the resulting output indicates the configuration error as follows:

```
Nov 23 14:00:56: Start of NEA TSP failed: No local NSAP
configured.
```

The TSPs can be started and stopped manually. It should be noted that when a TSP is stopped, all the active connections using it will be lost. These actions are available in the CMXCUI menu, *Transport Service Provider*.

Command syntax:

nea [**diag** | **start** | **stop**]

ntp [**diag** | **start** | **stop**]

tp02 [**diag** | **start** | **stop**]

start

starts the TSP after various checks. A message will be sent to default output if this TSP is already loaded.

start also starts those entries in the *crontab* file which in turn start the actions which are to be carried out at regular intervals. These check whether the TSP is still running and if not, restart it. These actions continue to be carried out until the TSP is stopped explicitly by the *stop* command or until three successive failures to restart have occurred. In both cases, the automatic execution of these actions will be stopped and an error entry will be written in the log file.

stop

stops the TSP. The operation outputs a message if the corresponding TSP is not loaded. If a TSP is stopped, it releases its reserved system resources. In this state, no communication is possible using this TSP. Regular actions called from the system's *crontab* file are also stopped. This status remains unchanged until the next start.

diag

Outputs a log file for the corresponding component.

Files:

Replace the following file name, *\$Name*, by the name of the corresponding TSP: NEA, NTP or TP02.

/var/opt/SMAWcmx/adm/log/\$Name.log
log file of the corresponding TSPs.

14.2 TSP statistics

Each TSP maintains an internal count of the number of connections, data transferred etc. This information can be called using the commands *neastat*, *ntpstat* or *tp02stat*. If the commands are given with the *-r* option, the counters are reset to their starting value, 0.

Command syntax:

neastat [-r]

ntpstat [-r]

tp02stat [-r]

-r

Rests the counter values.

14.3 Switching NEA routing on and off

You can switch NEA routing on or off or request the current status using the *neatune routing* command. The NEA routing becomes active immediately when it is switched on. However, deactivation using *neatune routing = off* only takes effect when the system is restarted. The setting are stored even after system shutdown.

neatune_routing[=*on*]*off*]

neatune routing

If no option is selected the current status is shown (routing on or off).

neatune routing=*on*

NEA routing is switched on.

neatune routing=*off*

NEA routing is switched off.

15 Diagnostics and Fault-finding

When CCP-WAN or CCP-WAN-LINK is run and when a Communications Controller is loaded, status information is automatically collected and written to various lists or files. The information contained in them is a valuable aid to fault-finding and system monitoring. The following information is logged:

- Traces

The traces log the CCP-WAN process steps. The traces are written to lists, containing the trace data with various trace points that you can specify and activate explicitly. The trace lists can be processed so that you can follow the program flow more easily.

- Statistics

Statistical lists provide information on instantaneous loading and failure rates of the line and memory area. Statistical lists about the progress of processing can, for example, yield a great deal of information about a connection with an X.25 network.

- Diagnostic files

These include files containing error messages and messages relating to network access software. The information in these files is continuously updated.

The following diagnostic and fault-finding tools are also available:

Tool	Brief description
x25chk, x25conf	Checking the functionality of an X.25 connection by dialling a mirror program in a public network node. For the X.25 connection to be tested, you can interactively create a configuration to be activated especially for the test procedure.
x25snoop	Switches on the line-specific X.25 protocol traces and off-line processing of the trace, using the Ethereal protocol analyser (available as freeware)
ccptron, ccptroff	Switch the most important CC traces on and off

Table 74: Diagnostic and fault-finding tools

15.1 Diagnostic files

The relevant diagnostics files for the communications controller and network access software are described below. These files do not have to be explicitly activated or deactivated and can be read without further processing. An exception is the ER list, which does require processing.

The error message field

The occurrence of serious communications controller errors and warnings is logged in the error message field (ER list). The list transfer for the ER list is switched on by default, i.e. you do not need to enter the *ton* command.

You must use the *tof* command to request a partial (incomplete) list. You can use the *format* command to process the transferred error message list to a readable form. As default, the trace lists are stored under

/opt/SMAW/SMAWcmx/lib/ccp/diagfiles/cc_ER_nr.bin, where *nr* = 0.1.

If, after entering the *tof* command, further ER lists are to be transferred, you must first enter the *ton* command.

The NEWSFILE file

Messages from the network access software are logged in the *NEWSFILE* file. There are two files that are written in parallel. They are stored in the directory */opt/SMAW/SMAWcmx/lib/ccp/diagfiles* under the name, *cc_NEWSFILE_nr* where *nr* = 0.1.

The messages appear as follows:

```
4108 NEWS FROM PROCESSOR 0/0: SYSTEM READY!  
4270 NEWS FROM PROCESSOR 0/0: PROCESSOR LINE ACTIVE, LINE 1
```

The DEBUGFILE file

The file *DEBUGFILE* file contains information on the network access software and the start time.

Access attempts by unauthorized partners are also recorded in the *DEBUGFILE*. Other information recorded includes date, time and addresses. (Note: the *DEBUGFILE* is deleted when the CC is reloaded.)

There are two files that are written in parallel. They are stored under the name */opt/SMAW/SMAWcmx/lib/ccp/diagfiles/cc_DEBUGFILE_nr* where *nr* = 0.1.

15.2 Traces and statistics

Traces

If you wish to generate trace lists, you must first enter the *son* and *ton* commands for the desired lists. With the *son* command, you can switch on trace lists and with the *ton* command, you can activate the trace list transfer from the communications controller. The transfer of the trace lists from the communications controller to a UNIX file always takes place at fixed intervals provided a list is full.

After testing, enter the commands *sof* and *tof*, where the *sof* command turns off the trace for a specific list and the *tof* command transfers the still incomplete lists from the communications controller. The transfer will then be switched off.

As default, the trace lists are stored under the name *cc_list_nr.bin* where *nr* = 0.1. The trace information is not printable but can be prepared for printing with the *format* command.

If, after entering the commands *sof* or *tof*, further trace lists are to be generated, you must enter the *son* and *ton* commands.

The following tables summarise the traces and their meanings.

Identification	Meaning
ER	Error message list **)
IN	NPI information on profile, TSP and addresses
IP	Interface signals of level 3, e.g. X.25
LP	HDLC and modem signalling
SL	sorted list *)
DU	dump *)

Table 75: Important traces

Identification	Meaning
SN	Multilink trace
LM	Layer Manager of layer 2
LI	Interface signals of layer 2

Table 76: Other traces

Identification	Meaning
LN	Line component signals
HP	Controller / host bus interface
AL	ADM list of the LMDE

Table 76: Other traces

The trace and statistics IDs can be given for the commands *format*, *son*, *sof*, *ton* and *tof*.

*) only for the *format* command.

**) for the *son* and *ton* commands, these IDs are already set automatically when the CCP starts

Statistical lists

Statistical lists are like trace lists in that you must switch on the transfer with the *ton* command.

If you enter the *tof* command, the most recent list entries (residual list) are transferred and the transfer is then switched off.

The lists are, for example, stored under *W2_LA_0.bin* or *W1_LV_1.bin*.

Identification	Meaning
SX	X.25 statistics ***)
LA	Line statistics ***)
LV	Resources statistics ***)

Table 77: Statistics

The trace and statistics IDs can be given for the commands *format*, *son*, *sof*, *ton* and *tof*.

***) for the *son* command, these IDs are already set automatically when the CCP starts.

15.3 ccptron, ccptroff – Switching traces on and off

The command *ccptron*, switches on the most important traces of a CC. *ccptron* automatically determines which are the traces to be switched on. In the case of a WAN controller, these are the traces IN, IP and LP. In the case of an ISDN controller, the traces are IN, IP, IS and LP. If no arguments are given, *ccptron* switches on the traces for every CC that, according to the *bstv info* command, is in the READY state.

ccptroff is used to switch the traces off again and convert them into a readable format. The *ccptroff* command also prepares error message field (ER list).

The readable and binary trace files are written to the directory */opt/SMAW/SMAWcmx/lib/ccp/diagfiles*.

ccptron [-b cc]

ccptroff [-b cc]

-b cc

defines a CC in the form, Wn, n = 1,...

Example:

```
ccptron -b W13
```

```
Attention: Previous trace lists are removed
```

```
ccptron/W13 : son && ton started for trace lists "in ip lp".
```

```
ccptroff -b W13
```

```
Analysis of TRACE list IN into file:  
/opt/SMAW/SMAWcmx/lib/ccp/diagfiles/W13_IN.txt
```

```
Analysis of TRACE list IP into file:  
/opt/SMAW/SMAWcmx/lib/ccp/diagfiles/W13_IP.txt
```

```
Analysis of TRACE list LP into file:  
/opt/SMAW/SMAWcmx/lib/ccp/diagfiles/W13_LP.txt
```

```
Analysis of TRACE list ER into file:  
/opt/SMAW/SMAWcmx/lib/ccp/diagfiles/W13_ER.txt
```

15.4 x25snoop – Carrying out line-specific X.25 protocol tracing

The *x25snoop* command provides diagnostic assistance for errors in connection with X.25. It provides line-specific tracing on the controller and off-line preparation of the protocol elements sent to the partner or received from the partner over this line. The output is prepared in user-readable form by using the Ethereal freeware graphic network protocol analyser. In addition to HDLC and X.25, the TP02 and TCP/IP logs are prepared. *x25snoop* can be used for:

- X.25 connections
- DTE-DTE couplings
- X.31
- X.32 2 level selection
- X.25 fixed connection to an ISDN controller

Given that *x25snoop* records the protocol elements exchanged over a line, *x25snoop* is not suitable for the analysis of local connection refusals.

x25snoop -s

Switches on a trace (LP data trace: `bstv son -b<cc> -tlp -ilx -l<line>`) on the controller, that copies the first 264 Bytes of each HDLC frames directly from the line. X.25 packets up to 256 Bytes in length are included in full. For longer packets, the first 259 Bytes of each X.25 data packet are included. The trace data are written periodically in two binary trace files whose size you can set with the *-m* option.

Do **not** turn on the LP trace on the controller at the same time. *x25snoop* cannot be used for several lines of a controller simultaneously.

x25snoop -t

Stops the trace and generates a file from the two binary trace files that can be prepared using Ethereal. This is saved in the standard directory for the controller traces and is named:

```
/opt/SMAW/SMAWcmx/lib/ccp/diagfiles/<cc>_IF<line>.rad <cc> = W1,...
```

In the case of an X.25 via ISDN where there are a number of B-channels, *x25snoop* generates an Ethereal input file for each B-channel on which there has been data traffic. The signals on the D-channel are not traced.

```
/opt/SMAW/SMAWcmx/lib/ccp/diagfiles/<cc>_IF<line>_B1.rad
```

```
/opt/SMAW/SMAWcmx/lib/ccp/diagfiles/<cc>_IF<line>_B2.rad
```

```
x25snoop -s -i
```

Instead of switching on the trace with *x25snoop -s* and switching it off with *x25snoop -t*, you can enter *x25snoop -s -i*.

In this case, press the **DEL** key to turn off the trace.

Switch trace on

```
x25snoop -s [-b cc] [-l line]
```

or

```
x25snoop -s -i [-b cc] [-l line]
```

Switch trace off

```
x25snoop -t [-b cc]
```

```
DEL
```

Trace file processing with Ethereal:

Ethereal is a network protocol analysis tool which you use to turn the trace data generated by *x25snoop* into a user-friendly form. You can either use *ethereal* to display the trace in a graphic window or *tethereal* to present it in text form.

For the method of calling these programs and the appearance of their outputs, see the examples on page 329 and page 332. There you will also find some notes on the graphical display with *ethereal*.

Ethereal is available as freeware for Solaris, Windows and some other operating systems (www.ethereal.com). For Solaris, Ethereal is shipped on the installation CD for CMX. Install the following packages:

- SMAWPbase
- SMAWPglib
- SMAWPgtk+
- SMAWPethe

With the standard installation of CMX, these packages are automatically installed. There are also man pages for *ethereal* and *tethereal* that can be called with *man*, as well as documentation in HTML, located in the directory, */opt/SMAWPlus/readme/SMAWPethe/html*.

Command syntax:

x25snoop -s [**-i**] [**-b** cc] [**-l** line] [**-m** size]

x25snoop -t [**-b** cc]

-s

Starts the trace for the selected line. The trace data are written periodically in two files whose size you can set with the *-m* option.

Example for cc = W1:

/opt/SMAW/SMAWcmx/lib/ccp/diagfiles/W1_LP_0.bin

/opt/SMAW/SMAWcmx/lib/ccp/diagfiles/W1_LP_1.bin

-i

x25snoop does not stop after the trace has been switched on but continues to output the size of the binary trace files every second. If you press **[DEL]**, the trace will be switched off and converted to the RADCOM format (see *-t* option).

-t

Stops the trace and generates an input file for Ethereal. The file is written to the standard directory for the traces of the controller. The file name includes the CC and the line.

Example for cc = W1:

/opt/SMAW/SMAWcmx/lib/ccp/diagfiles/W1_IF<line>.rad

In the case of X.25 via ISDN, *x25snoop* generates a file for each B-channel that carries data.

Example for cc = W2 and line = 1:

/opt/SMAW/SMAWcmx/lib/ccp/diagfiles/W2_IF1_B1.rad

/opt/SMAW/SMAWcmx/lib/ccp/diagfiles/W2_IF1_B2.rad

In the case of a fixed X.25 connection to a PWS0 controller, the forward slash in the line number is left out when forming the file name:

Example

/opt/SMAW/SMAWcmx/lib/ccp/diagfiles/W3_IF10.rad

-b_cc

defines a CC in the form, Wn, n = 1,...

If nothing is entered, the CC is requested. The request includes the valid values.

-l_line

Line number. The line number to be given can be found using *bstv linkstat -b_cc* under IF#. Possible values are:

PWXV-2: line = 1, 2

PWXV-4: line = 1, 2, 3, 4

PWS0: line = 1, 2, 1/0, 1/1, 1/2, 2/0, 2/1, 2/2

PWS2: line = 1

If nothing is entered, the line number is requested. The request includes the valid values.

-m_size

Maximum size of the binary trace files in Bytes.

Default value: 50,000 Bytes per file

Example:

```
x25snoop -s -i
Enter CC ( W1 | W2 ): W1
Enter line number ( 1 | 2 ): 1
Starting the LP trace on W1 line 1.
Trace successfully started.
```

Interactive mode:

```
x25snoop shows the sizes of the binary trace files and
updates
the values every second. Type DEL when the test is finished
and
you want to stop the tracing.
```

File names:

```
/opt/SMAW/SMAWcmx/lib/ccp/diagfiles/W1_LP_0.bin
/opt/SMAW/SMAWcmx/lib/ccp/diagfiles/W1_LP_1.bin
```

File sizes: 400 / 0

DEL

```
Starting the LP trace on W1 line 1.
```

File sizes: 608 / 0

TRACE list LP converted, file: /opt/SMAW/SMAWcmx/lib/ccp/diagfiles/W1_IF1.rad

Example for the graphical display with ethereal in Solaris:

```
DISPLAY=<Name des X-Servers>:0
export DISPLAY
ethereal -r /opt/SMAW/SMAWcmx/lib/ccp/diagfiles/W1_IF1.rad
```

The example shows an outgoing connection request (Call Request), that is refused (Clear Indication). The Clear Indication packet is marked. The bottom window shows the marked Clear Indication packet, including the LAPB header, in hexadecimal form. The middle window shows the detailed X.25 protocol structure of the packet.

The screenshot shows the Ethereal network analyzer interface. The top window displays a list of captured packets. Packet 9 is highlighted in blue, indicating it is selected. The packet details window below shows the structure of packet 9, including the LAPB header and X.25 protocol fields. The X.25 protocol structure is shown in a tree view, with the Logical Channel field expanded to show its value (256). The packet type is identified as 'Clear indication' and the cause is 'DTE originated'.

No.	Time	Source	Destination	Protocol	Info
1	0.000000	DTE	DCE	LAPB	U P, func = SABM
2	0.000000	DCE	DTE	LAPB	U F, func = UA
3	0.000000	DCE	DTE	X.25	Restart ind. Network operat
4	0.000000	DTE	DCE	LAPB	SRR, N(R) = 1
5	0.050000	DTE	DCE	X.25	Restart req. DTE originated
6	0.050000	1	026240890009022	X.25	Call req. VC:256
7	0.050000	DCE	DTE	LAPB	SRR, N(R) = 1
8	0.050000	DCE	DTE	LAPB	SRR, N(R) = 2
9	0.050000	DCE	DTE	X.25	Clear ind. VC:256 DTE orig
10	0.050000	DTE	DCE	LAPB	SRR, N(R) = 2
11	0.050000	DTE	DCE	X.25	Clear Conf. VC:256
12	0.050000	DCE	DTE	LAPB	SRR, N(R) = 3
13	0.050000	DTE	DCE	LAPB	U P, func = DISC
14	0.050000	DCE	DTE	LAPB	U F, func = UA

Frame 9 (7 bytes on wire, 7 bytes captured)
 LAPB
 X.25
 0001 = GFI: 1
 ... 0001 0000 0000 = Logical Channel: 256
 Packet type: Clear indication
 cause : DTE originated
 diagnostic : Unknown 252

0000 03 42 11 00 13 80 Fc .B... ..

Filter: / Reset Apply Logical Channel Number (x.25.lcn), 2 bytes

Setting colour markings (e.g. for transmit and receive directions):
You can define a colour marking for anything that can be filtered.

Colour-mark transmitted frames:

- ▶ In order to set colour marking, select the *Display* menu -> *Colorize Display*.
- ▶ Select *New* and enter a name.
- ▶ In order to fill in the *String* field, delete its contents and select *Add Expression*.
- ▶ Open *Frame*, *Point-to-Point Direction*, *==*, *Sent* and *Accept*.
- ▶ Select *Background Color*, a colour and click twice on *OK*.
- ▶ Click on *Apply* and then on *OK*.
- ▶ Select *Save*, to store this setting for the next call of *ethereal*.

Activating filtering (e.g. by protocol or VC):

Use one of the following methods:

- ▶ To activate a simple filter, write the desired filter string in the *Filter* field at bottom left and click on *Apply*.

Examples:

x.25	for X.25 protocol
cotp	for TP02 protocol
x.25.lcn == 10	for all X.25 packets on VC 10

or, alternatively:

- ▶ Mark a line in the middle window.
An expression will appear in the grey field at the bottom right.
- ▶ Use this expression as the filter.
- ▶ In order to activate this filter, select the *Display* menu -> *Match* -> *Selected*.

Defining a filter, using it, saving it for the next call and deleting it:

- ▶ Click in the filter field *Filter* at the bottom left.
- ▶ To define a new filter, fill in the fields *Filter name* and *Filter string* – using the option *Add Expression* – and click on new *New*.

The initial value of the *string* filter field is the currently active filter.

Show time:

The default setting of the time display is *Seconds since beginning of capture*, i.e. the time shown is the time from the first frame.

- ▶ To change the setting of the time display, open the *Display* menu -> *Options* and select one of the options, *Time of day* or *Date and time of day*.

Example of a trace displayed as text, using *tetherreal*:

```
tetherreal -r /opt/SMAW/SMAWcmx/lib/ccp/diagfiles/WI_IF1.rad

1 0.000000      DTE -> DCE          LAPB U P, func = SABM
2 0.000000      DCE -> DTE          LAPB U F, func = UA
3 0.000000      DCE -> DTE          X.25 Restart ind. Network
Operational - Diag.:7
4 0.000000      DTE -> DCE          LAPB SRR, N(R) = 1
5 0.000000      DTE -> DCE          X.25 Restart req. DTE
Originated - Diag.:0
6 0.000000      1 -> 026240890009022 X.25 Call req. VC:10
7 0.000000      DCE -> DTE          LAPB SRR, N(R) = 1
8 0.000000      DCE -> DTE          LAPB SRR, N(R) = 2
9 0.000000      DCE -> DTE          X.25 Clear ind. VC:10 DTE
Originated - Unknown 252
10 0.000000     DTE -> DCE          LAPB SRR, N(R) = 2
11 0.050000     DTE -> DCE          X.25 Clear Conf. VC:10
12 0.050000     DCE -> DTE          LAPB SRR, N(R) = 3
13 0.050000     DTE -> DCE          LAPB U P, func = DISC
14 0.050000     DCE -> DTE          LAPB U F, func = UA
```

15.5 x25chk, x25conf – X.25 connection test

For testing an X.25 connection on a PWXV controller, two commands are available:

x25chk

Test connection handshake and data transfer

x25conf

Interactive creation and loading of a test configuration (KOGS and KD) for the X.25 connection. Using the test configuration, the connection handshake can then be tested.

You can choose whether you wish to carry out the connection handshake test with the existing controller configuration or with a test configuration generated by *x25conf* for the X.25 connection. Generating a test configuration can be advantageous in case of uncertainty or when no configuration is yet available.

The test can be used for X.25 connections to a PWXV controller on a public or private X.25 network, that is accessible using SVC via the Deutsche Telekom DATEX-P network.

15.5.1 x25chk

x25chk carries out a connection handshake test (outgoing connection) and data transfer test on an X.25 connection to a PWXV controller. Necessary conditions are that the connection has outgoing SVC available and that the DATEX-P network is available. As a fixed test partner *x25chk* uses the ECHO function on the Munich network node of the Deutsche Telekom DATEX-P network which can be dialled using the DTE address 026240890009022. The ECHO function accepts the connection request and mirrors any data received. The connection is established by the WAN-X25 profile.

x25chk -i delivers the *linkstat* information for all lines configured on PWXV controllers.

Syntax

x25chk [-b_cc] [-l_line] [-n_count] [-s_size] [-q] [-e_address]

-b_cc

The PWXV controller should be entered in the form Wn, n=1,... .

If nothing is entered, the CC is requested. The request includes the valid values.

-l_line

Line number.

PWXV-2: line = 1, 2.

PWXV-4: line = 1, 2, 3, 4.

If nothing is entered, the line number is requested. The request includes the valid values.

-n_count

count = 0....1000,

Default: 0.

Optional data

After the connection is established and standard data have been sent, count TSDUs are sent to the ECHO function. *x25chk* sends a TSDU, waits for the data to be sent back and then compares it with the data sent. A least a second elapses after the TSDU is sent and then the next TSDU is sent. For each TSDU sent or received, *x25chk* outputs one line on the terminal. During waits, one dot is output per second. *x25chk* measures the runtime for the data and then outputs a statistic at the end.

-s_size

size = 1.....65536,

Default: 64

Length of a TSDU of optional data in Bytes.

-q

quiet option for the optional data.

Suppresses the output line for each TSDU sent or received.

-e_address

DTE address of the ECHO function to be dialled.

Default is 026240890009022, the ECHO function at the Munich network node.

x25chk -i

- i Shows *linkstat* information for all lines:
x25chk -i goes through all PWXV controllers and outputs the result of the *linkstat* command. All configured lines are shown. If a controller is not READY, the information is not available.

Return values

- 0 test successful, i.e. there are no connection or data transfer errors
- 1 test failed (errors)
- 2 Another *x25chk* command is already running.

Starting the connection request test

When calling *x25chk*, you can specify which connection on which controller is to be tested (options *-b_cc* and *-l_line*).

If you specify nothing when calling *x25chk*, there are the two following possibilities:

1. CC and line will be requested. The request includes the valid values.

```
Enter CC (W1): W1
Enter line number (1|2): 1
```

2. A test configuration was activated by a previous *x25conf* and CC and line were stored in a temporary file. *x25chk* will fetch the information via the CC and the line from this file but only if you specified nothing when calling the program. In this case, *x25chk* will respond with:

```
x25chk takes cc and line from 'x25conf':
cc = W1
line = 1
```

Testing connection request and data transfer with standard data

x25chk tests the connection request with the ECHO function of the Munich network node (DATEX-P). After a connection is successfully established, *x25chk* sends one short TSDU (10 Bytes) and one long TSDU (5000 Bytes) which are mirrored by the ECHO function. *x25chk* imposes a timeout on the return data (30s). While waiting, *x25chk* outputs dots (stops).

If a connection is established and data are successfully transferred, this shows that the local connection is in order and that outgoing connections basically work.

This does **not** test whether incoming connections work or whether the maximum number of simultaneous connections is possible. The VC number ranges could be wrongly generated.

If the connection cannot be established, *x25chk* outputs a possible cause according to CMX Reason and refers to the CCP traces that *x25chk* switches on by default.

The traces include X.25 Cause and the diagnostic Byte of the Clear Indication converted to text if the connection was refused. If the connection was refused locally, the local DISIN Reason is converted to text.

Traces as a diagnostic aid in the case of a fault

By default, *x25chk* turns on the most important traces of the controller and these can be used for diagnosis in the event of a fault. The traces are stored in the standard directory. If the connection was successfully established and the data were mirrored without error, the traces are not recorded. If one of the traces was already switched on before the *x25chk* call, *x25chk* does not switch on this trace again and does not record it.

```
/opt/SMAW/SMAWcmx/lib/ccp/diagfiles/W*_IN.txt  trace of the NPI provider
/opt/SMAW/SMAWcmx/lib/ccp/diagfiles/W*_IP.txt  X.25 Trace
/opt/SMAW/SMAWcmx/lib/ccp/diagfiles/W*_LP.txt  HDLC Trace
```

1. Any Clear Indication packet is to be found as CLRIN in the IP Trace (*W*_IP.txt*). The meanings of X.25 Cause and the diagnostic byte are output as text. The Call Request packet is shown as CALRQ.
2. If the line could not be connected, the IP trace (*W*_IP.txt*) will contain a DISIN with a reason code converted to text.

Example: Test of connection request and standard data

```
x25chk
Enter CC (W1): W1
Enter line number (1|2): 1

Connection establishment:
    trying to connect to 026240890009022 via W1:1
    connected

Data transfer:
    10 bytes transmitted ...
    10 bytes received
    5000 bytes transmitted ...
    5000 bytes received
```

Connection cleared.

Example: linkstat information output

```
x25chk -i
```

X25chk: information about lines on PWXV CCs

CC	IF#	STATE	TYPE	bit/s	LINK	LINKS	NETW.	SUBNET	SUBNET-ID	SUBNET-ADDR
W1	1	DISA	X.21	256k	-	0/1	-	LEASED	X25_1	-
W1	2	NETC	X.21	256k	-	0/1	-	LEASED	X25_2	-

W2 is not READY.

15.5.2 x25conf

Using *x25conf*, a test configuration (KOGS and KD) for an X.25 connection on a PWXV controller can be generated interactively and loaded for the connection request test. *x25conf* replaces the existing controller configuration with the test configuration. The test configuration remains active until unloaded with *x25conf -r*; this re-establishes the original configuration.

Syntax

```
x25conf
```

Generates and loads a test configuration

```
x25conf -r
```

Deactivates the test configuration and re-establishes the original configuration

x25conf works interactively. All test configuration parameters are requested in turn. Your inputs must match those with the entries from the network operator. *x25chk* checks the inputs for correct form and against general limit values. You can set standard values by pressing **RETURN**.

CC: all PWXV CCs will be proposed

Line number: all plugged-in lines will be proposed

X.25 according to CCITT: 1984/1988 or 1980

Local DTE address in Call not allowed (TRANSPAC): yes / no

TOA/NPI format according to CCITT 1988

local DTE address

SVC channel number range (incoming and outgoing or only outgoing SVC)

Packet size

Packet numbering

Window size

NUI

For the test configuration, enter the range of SVCs for incoming and outgoing connections or the range of SVCs on which only outgoing connections are possible. SVCs that are reserved for incoming connections and PVCs do not take part in the test. The test configuration does not, therefore, include the generation of all VC number ranges.

After a successful *x25conf* command, you do not need to give the CC and the line for *x25chk*. The configuration is used until *x25conf -r*. At the end of testing, call *x25conf -r* to deactivate the test configuration and reload the original configuration.

Example: Generating and loading test configuration

x25conf

X25conf: generating the test-configuration (KOGS)

```
-----
Enter CC (W1): W1
Enter line number (1|2): 1
```

In the next steps you have to enter some information that you obtained from your network provider. DEFAULT values come into effect with the ENTER key.

1. Does the interface run with an X.25 as defined in CCITT 1984/1988 (y) or with an X.25 CCITT 1980 (n), DEFAULT=y: y
2. Suppress the local DTE address in connection setup packets as in TRANSPAC (y/n), DEFAULT=n: n
3. Use of TOA/NPI format for DTE addresses in accordance with CCITT 1988 (y/n), DEFAULT=n: n
4. Enter local DTE address: 12345
5. Enter range of SVC numbers where outgoing connections are possible (e.g. 4-100): 1-4
6. Enter packet size in bytes. The value must be a power of 2. 16...128...2048, DEFAULT=128: 128
7. Enter packet numbering in modulo: mod8 or mod128, DEFAULT=mod8: mod8

8. Enter window size 1...2...7, DEFAULT=2: 2
9. Enter NUI assigned by the network provider,
DEFAULT=no NUI:

KOGS file: /opt/SMAW/SMAWcmx/lib/kd/kogs/wmulti/kx25chk
CF successfully created in file kx25chk.ccp

X25conf: loading the test configuration

Load test configuration? (y/n), DEFAULT=y: y
Changing the configuration of W1 ... Done.
The test-configuration has been successfully loaded.

With 'x25conf -r' you can load the original configuration
'klugel.ccp' on W1 or just unload the test-configuration.

You can now run 'x25chk'. cc=W1 and line=1 is retained.

Example: Restoring original configuration

x25conf -r
X25conf: restoring the configuration

The test configuration is currently loaded on W1:
W1 READY CCP-WAN kx25chk.ccp CCP-WAN kx25chk.ccp

Which configuration should be loaded on W1:
0: - (do not change)
1: klugel.ccp
Enter your selection (0|1): 1
Restoring the original configuration of W1 ... Done.

Files

/var/opt/SMAWcmx/tmp/X25CONF_R
contains the original configuration for *x25conf -r* and the CC and the line
for *x25chk*

/opt/SMAW/SMAWcmx/lib/kd/kogs/wmulti/kx25chk
generated KOGS

/opt/SMAW/SMAWcmx/lib/ccpwmulti/kd/allg/kx25chk.ccp
generated KD

Glossary

API (Application Program Interface)

APIs are program interfaces that provide the functions of a program system. A programmer uses the APIs when programming applications. APIs provide functions for connection management, data interchange and for representation of names within addresses. Sockets, ICMX and XTI are APIs in the CMX environment.

Applications

An application is a system of programs that uses specific services of an EDP system in order to provide a human or machine user with a higher level service. Communication applications are applications that use the communication functions of an EDP system together with a network to provide system-transcending services.

A prefix is added to most applications to define the underlying service (*CMX application*, UTM application, DCAM application, Motif application, Windows application, etc.). Examples of communication applications are file transfer, terminal emulation, electronic mail, World Wide Web browsers and servers, transaction systems such as UTM, in general all applications that work according to the client/server principle.

See also *TS application*.

ASCII code

International 7-bit based character set for DP systems (ISO 7-bit code).

CC (Communications Controller)

A CC is a module for connecting a UNIX computer to a network. You require a CC to physically connect your computer to a subnetwork, unless the connection is integrated into another module, e.g. the motherboard (onboard connection).

CCs are generally operated together with a corresponding *Communication Control Program (CCP)* to obtain a logical connection to the network. These CCs are known as loadable CCs. PWXV is an example of loadable CCs for connecting to X.25 networks. Loadable CCs are generally controlled by a *subnet connection*.

CCP (Communication Control Program)

A CCP is a program system (software product) which, together with one or more *CCs*, provides a UNIX computer with logical access to a *network*. A CCP implements the four lower layers of the OSI Reference Model (transport system) for data communications. CCP-WAN and CCP-ISDN are examples of CCPs for connection to X.25 and telephone networks, ISDN, and frame relay.

A CCP consists of a number of components, the *subnet connection* and the *Transport Service Providers*.

CCP profile

A CCP profile defines a specific protocol for each of the four lower layers in the *ISO Reference Model*, thereby defining specific network characteristics. A CCP contains at least one CCP profile.

CCP-ISDN

CCP for connecting a UNIX computer to an ISDN network.

CCP-WAN

CCP for connecting a UNIX computer to wide area networks, e.g. TRANSDATA. A CCP-WAN is a fully fledged *transport system* that exists in various guises.

CLI (Command Line Interface)

CLI is the sum of commands for *OA&M* of *CMX* and the *CCPs*. As the administrator, you can execute initialization, monitoring, control and maintenance functions of *CMX*, the *CCPs* and the *communication services* via the UNIX command line (the commands *cmxinfo*, *cmxm(onitor)*, *tnsxcom*, *bstv*, *ccpgen*, etc.).

CLIs offer a wide spectrum of options, some with complex syntax. The user interface *CMXCUI* enables simple, interactive handling of the required routine tasks.

CMX (Communications Manager UNIX)

CMX provides communications services for using *CMX applications* and *communication services* in the network and enables programming of *CMX applications*. *CMX* unifies the services of different networks, thereby allowing the same *CMX application* to be used regardless of the underlying network. As a runtime system, *CMX* mediates between the current network and *CMX applications* and offers the network administrator unified functions for *OA&M* (Operation, Administration and Maintenance)

of *CCPs* and *CCs*. As a development system, CMX provides interfaces (APIs) and processes for programming network-independent CMX applications.

CMX applications

CMX applications are applications that use the CMX services. They have an address in the network, the *TRANSPORT ADDRESS*. They identify themselves to each other with symbolic names, the *GLOBAL NAME* of an application.

CMXCUI (Character User Interface)

The CMXCUI is a character-oriented user interface for the *OA&M* functions of *CMX* and the *CCPs*. As the administrator, you can comfortably operate the *OA&M* via menus and forms. The CMXCUI uses FMLI and interfaces onto the *CLI*.

Communication partner

A *TS application* which maintains a logical connection to another *TS application* and exchanges data with it.

Communication service

Communication services serve for linking heterogenous networks with different architectures or different technologies. The use of communication services enables, for example, the most varied WAN/LAN links to be realized, whereby the corresponding communication service is a software component , e.g on a server.

Connection, logical

Assignment of two *communication partners*, enabling them to exchange data.

FSS (Forwarding Support Service)

The FFS is a *CMX* component that supports the correct addressing of applications in the network and the selection of a route through the *network* and its subnetworks. As the administrator, you can configure the FSS with the network-specific entries that you have foreseen for your network or have agreed with the network provider.

One important piece of information in the FSS is the representation of a network address, e.g. NEA address "47/11" on a subnetwork address of the remote computer e.g. the X.25 address "8963647658". A further important piece of information is the definition of a route with its local starting point and the various stations through the subnetworks to the

remote computer. The local starting point of a route is a *subnetwork ID* that uniquely identifies one specific subnetwork access from a number that are available.

GLOBAL NAME of an application

Each CMX application identifies itself and its communication partner in the network by means of symbolic, hierarchic GLOBAL NAMES. A GLOBAL NAME consists of up to five name parts (NP[1-5]) that you can use to define the application (NP5), the computer (NP4) and (up to three) administrative domains (NP[3-1]). *Example:* The GLOBAL NAME "YourApplication.D018S065.mch-p.sni.de" means: "YourApplication" resides in host "D018S065" in domain "mch-p.sni.de".

As the administrator, you must observe the specifications and recommendations of the special application when selecting a GLOBAL NAME.

As the administrator, you can assign the GLOBAL NAME of an application 1:1 a *TRANSPORT ADDRESS* or *LOCAL NAME* of an application. As a programmer, you can derive the *TRANSPORT ADDRESS* or *LOCAL NAME* expected by CMX from the GLOBAL NAME, using the *Transport Name Service* (TNS) function calls.

ISO Reference Model

Model for open systems communication. This is described in the ISO 7498 standard and contains seven layers.

KOGS (configuration oriented generator language)

KOGS is the configuration oriented generator language with which the physical and logical characteristics of the subnetwork connections of a computer are described in a text file. The KOGS language elements are macros, operands and operand values. The system or network administrator normally defines the specific characteristics of his subnetwork interfaces with the *CMXCUI*. He only uses the KOGS for this in exceptional cases.

LOCAL NAME of an application

A CMX application signs on to CMX for communication in your local computer with the LOCAL NAME. The LOCAL NAME consists of one or more T-selectors that each designate the transport system over which the CMX application is to communicate. As the administrator, you can use the LOCAL NAME to enable or disable the communication of a CMX application over specific transport systems and fulfill any requirements of the CMX application for specific T-selector values, e.g. for file transfer.

Example: an application is to use the T-selector "cmxappl" (lower case) for communication via the TCP/IP-RFC1006 transport system and the T-selector "\$CMXAPPL" (upper case) for communication via the NEA transport system.

As the administrator in CMX, you can assign the LOCAL NAME of an application to the GLOBAL NAME of the application. As a programmer, you can derive the LOCAL NAME expected by CMX from the GLOBAL NAME, using the *Transport Name Service* (TNS) function calls.

Message

A logically related data set which is to be sent to a *communication partner*.

Network

A network is a linkage of interrelated transfer components (lines, exchange nodes, processes) with uniformly defined services, protocols and access setups for EDP systems. A network connects computers for using system-transcending applications together. The network of a network provider can be used immediately for applications or for definition of private network structures that build on and overlay it. The following networks are relevant in the UNIX environment: the Internet, SNA, TRANSDATA and OSI networks.

A network can consist of a number of *subnetworks* that are linked via the homogenous end-to-end network protocol. The above example networks can be overlays of public or private subnetworks such as the X.25, telephone, data, ISDN or ATM networks and various private, local networks based on Ethernet, Token Ring and FDDI.

Network address

Each computer in a *network* is uniquely identified by its address. A computer can be linked into different networks and then has a specific network address for each of these networks. In the Internet, a computer has an address (IP address) that is made up of the network and host number (e.g. 129.144.89.171). In NEA networks, a computer has an NEA network address that is made up of computer/region numbers (e.g. 124/213). The OSI network address (NSAP address) is made up of the Initial Domain Part (IDP) and Domain Specific Part (DSP) and has the format IDP+DSP (e.g. 470058+0144458100007391100308001411961301).

OA&M (Operation, Administration and Maintenance)

OA&M is the sum of the functions for startup, operation monitoring and control, configuration and maintenance of the CMX and CCP components. The main OA&M activities in the CMX environment are loading and monitoring a CC, configuring the CCP runtime parameters and switching traces.

The simple, interactive handling of routine tasks in OA&M are provided by the *CMXCUI*. You can also use the CLI for special, unusual administration tasks.

OSI Reference model

Open Systems Interconnection is the communication architecture defined by the International Standards Organization ISO in the ISO 7498 standard. It defines reliable data interchange between applications that run on different hardware platforms. The OSI Reference Model defines seven part tasks for solving this complex overall task. These are arranged in hierarchical layers with each of these part tasks being carried out by a specific layer. The lower four layers represent the *transport system*, the upper three layers represent the viewpoint of the *application*, e.g. the data formats.

PDN application

A *TS application* that runs in TRANSDATA PDN on a communications computer.

Process

A process is the execution of a program. It consists of the executable program, the program data and process-specific administration data which is necessary to control the program.

Processor

TRANSDATA instance in the host or communication computer which can be addressed from any point in the network and in which the transport services are provided.

Processor name

Part of the *TRANSDATA address*. The processor name has the following syntax:
processor number/region number.

Route

Route describes the path from the local computer to a remote computer within a *subnetwork*. If the remote computer is in a different subnetwork from the local computer, the route then describes the path from the local computer to the network interconnection (“next hop”) from which the further routing to the remote computer takes place. A route is defined by its end points: the *subnetwork ID* of the local computer and the *subnetwork address* of the remote computer if the remote computer is in the same subnetwork or the subnetwork address of the “next hop” if the remote computer is not in the same subnetwork.

If a computer has more than one subnetwork address, it can be reached over more than one route.

Software configuration

This is a defined combination of versions of software products that together cover a limited and verified performance spectrum.

A software configuration of CMX and CCP product versions guarantee their defined interoperability. This is ensured by quality control measures. Unexpected dropouts and failures with undefined results can occur if CMX and CCP product versions are mixed that are not expressly defined as compatible.

Subnetwork

A subnetwork is a technically or administrative homogenous part of a *network*. Subnetworks include the X.25, telephone, data, ISDN and ATM networks and various private, local networks based on Ethernet, Token Ring and FDDI. A subnetwork can be accessed via one or more subnetwork accesses. A subnetwork access is identified by its *subnetwork address*.

Subnetwork address

The subnetwork address uniquely describes one subnetwork access that allows access to the *subnetwork*. An ISDN subscriber number, a DTE address or an Ethernet address are examples of subnetwork addresses.

Subnetwork ID

The subnetwork ID, also known as SNID, describes a group of similar subnetwork accesses that lead to the same *subnetwork*. The subnetwork ID defines the type of subnetwork and identifies which group of accesses to this subnetwork it is. A subnetwork ID can, for example, stand for two ISDN connections or a number of X.25 connections in one subnetwork.

T-selector

The T-selector identifies a communications application within the computer on which the application runs. The T-selector, together with the *network address* of the computer, forms the *TRANSPORT ADDRESS* of an application with which the application can be uniquely addressed within a network. The T-selector format and value range depend on the type of *network*. The T-selector corresponds to the station name in the NEA network (e.g. T'DSS01').

TNS (Transport Name Service)

The TNS is a *CMX* component that supports the correct representation of the *GLOBAL NAMES* of *CMX applications* in the network, into *TRANSPORT ADDRESSES* and *LOCAL NAMES*. As the administrator you configure your selected assignment of GLOBAL NAME to TRANSPORT ADDRESS for remote applications and the assignment of GLOBAL NAME to LOCAL NAME for local applications. As an applications programmer you can use these representations via an API and thereby work with the GLOBAL NAME of applications alone, without evaluating the representations. The TNS offers application identification throughout the network by means of logical GLOBAL NAMES and their representation in a corresponding *network address*. This allows you to decouple the applications from knowledge of their network address. The TNS together with the FSS offer complete representation of the logical name in a concrete *subnetwork address* and *route* through the various subnetworks in the network.

TNSADMIN

Acquisition program for the *Transport Name Service* in *UNIX*.

TRANSPORT ADDRESS of an application

A calling *CMX application* passes the TRANSPORT ADDRESS of a called communication partner to *CMX* during connection setup. *CMX* uses the TRANSPORT ADDRESS to localize the communication partner in the network and define a *route* through the network. The TRANSPORT ADDRESS depends generally on the logical and physical structure of the network (and its subnetworks). The TRANSPORT ADDRESS contains the network-specific specifications of its network provider(s). As the administrator, you can influence the TRANSPORT ADDRESS and the communication route, independent of the application.

Integral parts of a **TRANSPORT ADDRESS** are: a network address for unique identification of the remote computer on which the application resides, the type of the *transport system* over which the remote application can be reached and the *T-selector* which identifies the remote application in the remote computer.

Examples of network addresses are: the Internet address in the point notation "192.11.44.1", the NEA address in the processor/region number notation "47/11" and the X.25 address (DTE address) as a numeric string "45890010123".

As the administrator, you can assign the **GLOBAL NAME 1:1** a **TRANSPORT ADDRESS**. As a programmer, you can derive the **TRANSPORT ADDRESS** expected by CMX from the **GLOBAL NAME**, using the *Transport Name Service* (TNS) function calls.

Transport connection

Assignment of two communication partners that enables them to exchange data.

Transport system

The transport system designates the lower four layers of the *OSI Reference model*. A *CCP* implements the four layers of the transport system. The transport system ensures secure data interchange between computers whose *applications* communicate with each other, independently of the underlying network structures. The transport system uses protocols for this.

TS application

This is an application that uses the services of the transport system. It consists of programs that can set up a logical *connection* to another **TS** application in order to exchange data with it.

TS directory

Database containing information about the *TS applications*. The **TS** directory is managed by means of the *Transport Name Service*

TSP (Transport Service Provider)

A TSP is a component of a CCP or CMX that provides the OSI transport services, apart from the NTP (Null Transport), in the network by means of a transport protocol. As the administrator, you can define the use of a specific TSP for the communication of *applications*. RFC1006 is the TSP in CMX that provides the OSI transport services, together with TCP/IP in the Internet. The NTP offers CMX applications direct access to the network services of the X.25 subnetwork. TP0/2 and NEA are the TSPs for an OSI environment and the TRAANSDATA network.

A TSP together with a *subnet profile* forms a *transport system*. It provides a set of configurable runtime and tuning parameters, evaluates the *TRANSPORT ADDRESS* and finds a suitable route through the network. The TSP uses your entries in the *FSS* if necessary.

Abbreviations

ASCII

American Standard Code of Information Interchange

ATM

Asynchronous Transfer Mode

CC

Communications Controller

CCITT

Comité Consultatif International Télégraphique et Téléphonique

CCP

Communication Control Program

CIR

Committed Information Rate

CMX

Communications Manager UNIX

DCAM

Data Communication Access Method

DCE

Data Circuit Terminating Equipment

DMA

Direct Memory Access

DTE

Data Terminating Equipment

EBCDIC

Extended Binary Coded Decimal Interchange Code

EBNF

Extended Backus Naur Form

Abbreviations

EMDS

Emulation of data display terminals

EOF

End of File

EOS

End of String

ETHN

ETHERNET

ETSDU

Expedited Transport Service Data Unit

FT

File Transfer

FSB

Forwarding Support Base

HDLC

High Level Data Link Control

ICMX

Program interface for CMX

IS

Intermediate System

ISDN

Integrated Services Digital Network

ISO

International Organization for Standardization

ITU

International Telecommunication Union

ITU-T

Telecommunication Standardization Sector

KD

German abbreviation for “configuration file”

KOGS

Configuration orientiert generator language

KR

German abbreviation for “communication computer”

LAN

Local Area Network

MES

German abbreviation for “menu development system”

MSV1

Transmission protocol: Medium Speed Variant 1

NEA

Network architecture for TRANSDATA systems

NSAP

Network Service Access Point

OSI

Open Systems Interconnection

PDN

Program system for remote data processing and network control

PID

Process Identifier

PVC

Permanent Virtual Circuit

QD

German abbreviation for “source file”

REMOS

Remote Operation System for linking LANs

Abbreviations

RFC

Request for Comments

SNA

Systems Network Architecture

SNID

Subnetwork identification (also called a subnet ID)

SNPA

Subnet Point of Access

STA

Station link

TCEP

Transport Connection Endpoint

TCP/IP

Transmission Control Protocol/Internet Protocol

TEP

Transport Endpoint

TIDU

Transport Interface Data Unit

TLI

Transport Level Interface

TNSX

Transport Name Service in SINIX

TPDU

Transport Protocol Data Unit

TR

Token Ring

TREF

Transport Reference

TS

Transport Service

TSAP

Transport Service Access Point

TSDU

Transport Service Data Unit

TSTAT

TEP Status

VAR

German abbreviation for “host computer”

WAN

Wide Area Network

XTI

X/OPEN Transport Interface

Related publications

The manuals are available as online manuals, see <http://manuals.fujitsu-siemens.com>, or in printed form which must be payed and ordered separately at <http://FSC-manualshop.com>.

- [1] **CMX V6.0** (Solaris)
Operation and Administration
User Guide

Target group
System administrators

Contents
The manual describes the function of CMX as mediator between applications and the transport system. It contains basic information on configuration and administration of systems in network environments.

- [2] **CMX V6.0**
Programming Applications
Programmer Reference Guide

Target group
Programmers

Contents
The manual describes the program interface of CMX, i.e. all tools that you can use for developing TS applications.

- [3] **CMX/CCP V6.0** (Solaris)
ISDN Communication
User Guide

Target group
Network administrators

Contents
The manual describes the computer-to-computer connection via ISDN (Integrated Services Digital Network).

Related publications

- [4] **CMX V6.0 (Solaris)**
TCP/IP via WAN/ISDN
User Guide

Target group

Network and system administrators.

Contents

The manual describes how CMX enables the connectionless IP traffic via the connection-oriented WAN.

- [5] **Interfacing to SNA Networks**
TRANSIT-BAS
Core Manual

Target group

Solaris users in SNA networks

Contents

Basic description of the TRANSIT products

Other publications

- [6] DATEX-P-Handbuch
Deutsche Bundespost Telekom
Fernmeldetechnisches Zentralamt Darmstadt: 1988
- [7] **"CCITT Yellow/Blue/Red Book"**
CCITT Yellow Book
Recommendations of X.3, X.25, X.28, X.29 X.31 and X.32 on packet-switched data transmissions services
UIT Genf 1980
CCITT Red Book
Recommendations of X.3, X.25, X.28, X.29 X.31 and X.32 on packet-switched data transmissions services
UIT Genf 1984
CCITT Blue Book
Recommendations of X.3, X.25, X.28, X.29 X.31 and X.32 on packet-switched data transmissions services
UIT Genf 1988
- [8] **CCITT Empfehlungen der V-Serie und der X-Serie**
Datenübermittlung (Übersetzungen) Tietz, W.
5. Auflage Band 1 bis Band 7
R. v. Deckers Verlag, G. Schenk Heidelberg: 1985 - 1987

Index

! - execute a shell command 314
- comment lines in a command file
315
: - change administered CC 313
? - list commands 314

A

access
to the expert mode 65
to the menu system 64
access control 51
access control information
entry 73
ach - activate line 293
action
(fssadm command) 269
address
NSAP 71
SNID 70
SNPA 70
address format
SDLCBKA 178
WAN3SBKA 155, 211
WANNEA 88, 112, 210
WANSBKA 132, 211
addressing
for X.32 dialing 48
administration 289
CC 289
command overview 290
commands 291
expert mode 289
subnet profile 289
administrator menu SYSADM 64
ADRTYP 261
agreement of flow control parameters
35
agreement of throughput class 35
AKFACI 238
alternative network connection 44

alternative network port
WAN-CONS 141
WAN-NX25 119
WAN-X25 171
alternative route
in another subnetwork 45
assign
configuration file 66
configuration file (command) 67
configuration file (menu system)
66
network access software 66
network access software
(command) 67
network access software (menu
system) 66
assign - assign network access
software 294
asynchronstation 17
AUTO (setup of a dial-up connection)
251
AUTO/ABG (setup of a dial-up
connection) 251
AUTO/ANK (setup of a dial-up
connection) 251
automatic selection 24

B

Bc, see Committed Burst Size
Be, see Excess Burst Size
bilaterally closed user group 32
breakdown 28
bundled
parallel lines 23, 79
busy connection 44

C

call
incoming 238
switched virtual 12
call accept packet 239

Index

- call accepted 30
- call number 243
 - local system (dial-up line) 252
 - preset 24
- call retries 252
- CC
 - administration 289
- CC (Communications Controller) 17
- CC memory
 - dump 303
- CC, see Communications Controller
- CCITT recommendation 25
- CCP profile
 - select 294
 - WAN-CONS 57, 121
 - WAN-FR 185
 - WAN-NEA 57, 77
 - WAN-NX25 57, 101
 - WAN-SDLC 173
 - WAN-X25 58, 143
- CCP profilel
 - WAN-FR 58
 - WAN-SDLC 58
- CCP, see Communication Control Program
- CCP-ISDN 1
 - TSP 317
- CCP-ISDNS0-LINK 1
- ccptroff - switch traces off 325
- ccptron - switch traces on 325
- CCP-WAN 1, 7
 - deinstallation 75
 - operating 59
- CCP-WAN-LINK 1, 7
- CCP-WAN-NEA
 - functionality 77
- CCP-WAN-NX25
 - functionality 101
- CF, see configuration file
- channel
 - logical 11
 - logical channels to the X.25 network 253
 - one-way 33
 - virtual 13
- channel number 13, 30
- channel range
 - for PVC 247
- character-oriented DTE 17
- character-oriented user interface 2
- CIR, see Committed Information Rate
- circuit
 - permanent virtual 13
- Circuit Switched Data Network 10, 57
- circuit switching network 10
- clear-down request 31
- clearing down
 - a switched connection 31
- closed user group 32, 34, 51
- cmdfile - execute a command line 313
- CMX 1
- CMX menu
 - expert mode 289
 - options 67
- CMX, see Communication Manager UNIX
- CMXCUI 8
- command
 - ach 293
 - administration 293
 - assign 67, 294
 - ccptroff 325
 - ccptron 325
 - cmdfile 313
 - compile 295
 - cronstart 295
 - cronstop 295
 - dah 296
 - diagnostics 303
 - dump 303
 - exchange 297
 - expert mode 314
 - format 303
 - info 298, 299
 - linkstat 299
 - load 68, 301
 - overview 290

- sof 306
- son 308
- stop 302
- syntax 291
- tof 310
- ton 311
- x25snoop 326
- command file
 - enter comment lines 315
 - execute 313
- comment
 - KOGS source file 226
 - line comment 226
- Committed Burst Size 41
- Committed Information Rate 19, 41
- communication
 - with X.25 via phone networks 48
- Communication Control Program 7
- Communication Manager UNIX 2
- Communication Manager Unix 8
- communication partners
 - X.25 11
- communication protocol 255
- Communications Controller 2, 7, 17, 224, 341
 - change 313
 - memory dump 303
 - startup 59
 - status information 299
- compile 295
 - configuration file 65
 - KOGS source file 63
- compile - compile configuration
 - source file 295
- compile KOGS source file 224
- configuration file 59, 62, 64, 223, 224
 - assign 66
 - assign (command) 67
 - assign (menu system) 66
 - compile 65
 - create 64, 223
 - create with the editor 223
 - create with the menu system 223
 - delete 64
 - edit 63
 - edit (expert mode) 65
 - edit (menu system) 64
 - exchange 297
 - load 59, 66, 68
 - loadable 65
- configure
 - default route 80, 102
 - network access software 63
 - partner system 59, 69
 - subnet connection 62
 - subnetwork interface (WAN-CONS) 134
 - subnetwork interface (WAN-FR) 195
 - subnetwork interface (WAN-NEA) 89
 - subnetwork interface (WAN-SDLC) 179
 - sub-network interface (WAN-X25) 157
 - subnetwork interface (X.32 dialing) 213
 - transport system application 72
 - with editor 223
 - with menu 223
- connect indications
 - assignments to applications (WAN-X25) 162
- connection
 - alternative 44
 - busy 44
 - failed 44
 - indirect 13
 - logical connections to the X.25 network 254
 - multiplex 28
 - multipoint 255
 - of same type 44
 - point-to-point 255
 - via circuit switching networks 8
 - via packet switching networks 8
 - virtual 11, 12, 13
- connection setup 30

Index

- control method
 - for data transfer 24
- control procedure
 - HDLC LAPB 27
- create
 - configuration file 64, 223
 - FSS object 269
- create (FSS action) 269
- CSDN, see Circuit Switched Data Network
- CTIMER 243
- D**
- dah - deactivate line 296
- Data Circuit-Terminating Equipment 12
- data circuit-terminating equipment
 - 15, 16
 - type 244
- Data Link Connection 19
- Data Link Connection Identifier 19, 39
- data packets 12
- data terminal equipment 17
 - character-oriented 17
 - link 26
 - packet-mode 17
 - packet-oriented 11
- Data Terminal Equipment, see DTE
- data transfer 31
 - frame relay 40
- data transmission control procedure 24
- Datex-P 10
- Datex-P network 56
- DCE 16
- DCE, see data circuit-terminating equipment
- DEBUGFILE 322
- dedicated line 10
 - WAN-CONS with T.70 139
 - WAN-NEA balanced 93
 - WAN-NEA unbalanced 98
 - WAN-SDLC 181
- dedicated virtual connection 30
- default configuration
 - KOGS source file 223
- default route
 - configure 80, 102
- default router 80, 102
- define
 - facility 237
 - line operand 243
 - link address 259
 - network address (WAN-NEA) 90
 - network address (WAN-NX25) 114
 - route (WAN-CONS) 130, 135
 - route (WAN-FR) 193, 196
 - route (WAN-NEA) 87, 90
 - route (WAN-NX25) 111, 114
 - route (WAN-X25) 150, 158
 - route (X.32 dialing) 209, 215
 - subnet ID 261
 - XID exchange 259
- deinstallation
 - CCP-WAN 75
- delay
 - transmission of data 243
- delete
 - configuration file 64
 - FSS object 269
- delete (FSS action) 269
- describe
 - line interface 243
- diagnostics 289, 321
 - commands 303
 - error message field 322
 - file, DEBUGFILE 322
 - file, NEWSFILE 322
 - files 322
- diagnostics commands
 - list 314
- dial up connection
 - setup 251
- dial-nr 284

- dial-up line
 - remote dialing (WAN-NEA) 95
 - WAN-CONS with T.70 140
 - WAN-SDLC 182
- direct link
 - WAN-SDLC 183
- DIREKT (setup of a dial-up connection) 251
- DLCI, see Data Link Connection Identifier
- DTE 17
- DTE address
 - own 243, 263
- DTE name 73, 74
- DTE, see data terminal equipment 11
- DTEADCA 239
- dte-addr 285
- DTEADR 243, 263
- DUETYP 244
- dump
 - designation 304
 - prepare 303
- dump - CC memory dump 303
- dump list
 - file name 305
- E**
- edit
 - configuration file (expert mode) 65
 - configuration file (menu system) 64
 - KOGS source file 63, 223
- editor
 - configure 223
- end
 - KOGS 237
- end system (ES) 104
- enter
 - partner system 59
 - partner system (menu system) 71
 - partner system (WAN-CONS) 136
 - partner system (WAN-FR) 196
 - partner system (WAN-NEA) 91
 - partner system (WAN-NX25) 115
 - partner system (WAN-X25) 160
 - partner system (X.32 dialing) 217
 - route (menu system) 70
 - transport system application (menu system) 72
 - transport system application (WAN-CONS) 136
 - transport system application (WAN-NEA) 92
 - transport system application (WAN-NX25) 116
 - transport system application (WAN-SDLC) 180
 - transport system application (WAN-X25) 161
 - transport system application (X.32 dialing) 218
- ER list 322
- Ethereal
 - trace preparation 327
 - trace preparation (graphic) 330
- Excess Burst Size 41
- exchange
 - SNA-XID 173
- exchange - exchange configuration file 297
- expert mode 65, 289
 - access 65
 - commands 314
- F**
- FACIL 240, 244, 245, 263, 273
 - WAN-CONS 127
 - WAN-FR 190
 - WAN-NEA 84
 - WAN-NX25 107
 - WAN-X25 148, 151
 - X.32 dialing 205
- facil 286
- facilities 24
- facility 244, 245
 - define 237
 - WAN-CONS 127

Index

- WAN-FR 190
 - WAN-NEA 84
 - WAN-NX25 107
 - WAN-X25 148, 151
 - X.25 partner 169
 - X.32 dialing 205
 - failure
 - of a connection 44
 - of local connection 44
 - FASTSEL 238
 - fault-finding 321
 - error message field 322
 - feature
 - X.25 network 32
 - flow control parameters
 - agreement 35
 - Forwarding Support Information Base 269
 - Forwarding Support Service 59, 69, 269
 - frame 27
 - frame relay 10, 58
 - characteristics 18
 - communication partner 18
 - data transfer 40
 - priority of the PVCs 41
 - protocols 18
 - PVC 39
 - subnetwork interface 36
 - terminal device 39
 - frame relay network 56
 - frame relay protocols 36
 - frame relay switch 19
 - FRMRANZ 245
 - front-end processor 17
 - fr-pvc 285
 - FSB, see Forwarding Support Information Base
 - FSS action
 - create 269
 - delete 269
 - get 270
 - set 269
 - FSS attribute
 - dial-nr 284
 - dte-addr 285
 - facil 286
 - fr-pvc 285
 - internet-addr 281
 - line-nr 285
 - nea 282
 - nea-addr 281
 - phone-nr 284
 - pvc-nr 285
 - snpa-list 282
 - subnet 283
 - type 284
 - x32-phone-nr 286
 - FSS configuration 269
 - FSS parameter
 - WAN-CONS 127
 - WAN-FR 190
 - WAN-NEA 84
 - WAN-NX25 107, 147
 - WAN-SDLC 178
 - WAN-X25 147, 151
 - X.32 dialing 205
 - FSS, see Forwarding Support Service
 - fssadm 269
 - functionality
 - CCP-WAN-NEA 77
 - CCP-WAN-NX25 101
 - WAN-CONS 121
 - WAN-FR 185
 - WAN-NX25 101
 - WAN-SDLC 173
 - WAN-X25 143
- G**
- generalized NSAP
 - WAN-NEA 85
 - WAN-NX25 109
 - generator language, configuration-oriented (KOGS) 224
 - get (FSS action) 270

- GNSAP 279
 - select route from multiple entries 279
 - WAN-NEA 85
 - WAN-NX25 109
- grouped
 - lines 79
- H**
- half-duplex mode 256
- HDLC 57
- HDLC connection 255
- HDLC frame 27
- HDLC LAPB
 - control procedure 27
- HDLC protocol variant
 - balanced 255
 - LAPB 255
 - unbalanced 255
- HDLC protocol variants 246
- HDLC/BAC 255
- HDLC/LAPB 255
- HDLC/UNB 255
- help function 313
 - ! 314
 - # 315
 - : 313
 - ? 314
- I**
- ICMX (program interface) 2, 155
- identification
 - local subnetwork 262
 - own system 280
 - routes 283
- identification exchange 248
- incoming call 238
- incoming call dispatching table 162
- indirect connections 13
- info - query CC status 298
- initial startup 62
- initial window size 33
- Installation 60
- interface
 - data remote control unit 244
 - subnet 57
 - subnetwork 56
 - V.24 27
 - X.21 27
 - X.21bis 27
 - X.25 27
- interface type
 - NEA via HDLC 57
 - NEA via X.25 57
 - OSI via T.70 57
 - OSI via X.25 57
 - SNA via SDLC 58
 - SNA via X.25 58
 - TCP/IP via frame relay 58
 - TCP/IP via X.25 58
 - X.29 via X.25 58
- interface types 57
- Intermediate System (IS) 104
- internet-addr 281
- IS 7776 11, 25
- IS 8208 11, 25
- ISO class 0/2 (transport protocol) 56
- ISO standard 25
- K**
- KOGS 65
 - configuration-oriented generator language 224
 - end 237
 - start 262
- KOGS macro
 - overview 229
 - XEND 237
 - XFACI 237
 - XLTNG 243
 - XPRO 259
 - XSNID 261
 - XSYS 262
 - XZSTW 263

Index

- KOGS parameter
 - WAN-CONS 124
 - WAN-FR 189
 - WAN-NEA 82
 - WAN-NX25 105
 - WAN-SDLC 176
 - WAN-X25 145
 - X.32 dialing 201
- KOGS source file
 - blank line 226
 - call sequence for KOGS macros 228
 - comments 226
 - compile 63, 224
 - configure 223
 - default configuration 223
 - edit 223
 - end-of-line character 226
 - macro call 225
 - syntax 225
 - uppercase and lowercase 225
- L**
- level 2 27
- level 3 28
- line
 - activate (ach) 293
 - deactivate 296
- line interface
 - describe 243
- line level 27
- line number 245
- line operand
 - define 243
- line port
 - identification 245, 263
- line-nr 285
- lines
 - bundled 79
 - grouped 79
- link address
 - define 259
 - own 259
 - partner 259
- link level 27
- LINKADR 259
- load
 - configuration file 59, 66, 68
 - network access software 59, 66, 68
 - SNP 68
- load - load network access software 301
- loadable configuration file 65
- local network address
 - WAN-CONS 129
 - WAN-FR 191
 - WAN-NEA 85
 - WAN-NX25 110
 - WAN-X25 149, 153
 - X.32 dialing 207
- local packet switching center 16
- local subnet connection 62
- local subnetwork
 - identification 262
- LOCNSAP 280
 - WAN-CONS 129
 - WAN-FR 191
 - WAN-NEA 85
 - WAN-NX25 110
 - WAN-X25 149, 153
 - X.32 dialing 207
- logical channel 11, 13
- LPUFADR 245, 263
- M**
- macro
 - call sequence 228
 - XFACI
 - PAKLE 240
 - XSYPSP 237
- macro call
 - syntax 225
- macro language KOGS 65
- main line 15, 16
 - configuration 16
- manual selection 24
- MANUELL (setup of a dial-up

- connection) 251
 - MANUELL/ABG (setup of a dial-up connection) 251
 - MAXIFL 245
 - Maximum Transit Delay 41
 - menu
 - operations for Communications Controller 67
 - operations on remote systems 71
 - operations on routes 70, 73, 74
 - operations on transport system applications 72
 - select network access 65
 - select the network access software 64
 - menu option
 - assign local name 72
 - assign transport address 72
 - CFs - CCP configuration files 65, 66
 - change configuration 67
 - create 70
 - Enter expert mode 67
 - load CC 68
 - NSAPs 71
 - route - route to remote subnetwork interfaces 70, 73
 - SUBNET 73, 74
 - transport system application 72
 - unload 67
 - menu system 64
 - access 64
 - MLNK 245
 - MODE 245
 - modify
 - configuration file 64
 - MODTAKT 246
 - monitoring period
 - connection request 241
 - for receipt of outstanding acknowledgments for data packets 242
 - pending acknowledgments for data packets 242
 - reset request 242
 - restart request 241
 - send an RR or RNR packet 242
 - monitoring time
 - RR or RNR packets 242
 - multilink 23, 79
 - multilink number 79, 245
 - multiple profile 2
 - multiplex 28
 - virtual connection 28
 - multipoint connection 23, 255
- N**
- NAME 264
 - name
 - facilities 244, 245
 - NEA 56, 57
 - NEA routing 104, 320
 - switching off 320
 - switching on 320
 - NEA transport protocol 8
 - nea-addr 281
 - net 282
 - network
 - circuit switching 10
 - packet switching 11
 - network access software 56, 59
 - assign 66
 - assign (command) 67
 - assign (menu system) 66
 - assign to Communications Controller 67
 - configure 63
 - load 59, 66, 68, 301
 - stop 302
 - WAN 56

- network address 16
 - define (WAN-NEA) 90
 - define (WAN-NX25) 114
 - enter 71
 - local (WAN-CONS) 129
 - local (WAN-FR) 191
 - local (WAN-NEA) 85
 - local (WAN-NX25) 110
 - local (WAN-X25) 149, 153
 - local (X.32 dialing) 207
 - remote (WAN-CONS) 129
 - remote (WAN-FR) 192
 - remote (WAN-NEA) 86
 - remote (WAN-NX25) 110
 - remote (WAN-X25) 150, 153
 - remote (X.32 dialing) 207
- network address type
 - WAN-X25 150
- network connection 223
 - alternative 44
- network link
 - for communication with X.25 48
- network port
 - alternative (WAN-CONS) 141
 - alternative (WAN-NX25) 119
 - alternative (WAN-X25) 171
- Network User Identification 240, 277
- NETZTYP 264
- NEWSFILE 322
- NOREVCH 238
- notational conventions 3
- NRZI 246
- NRZI signaling scheme 246
- NSAP 71, 281
 - WAN-CONS 129
 - WAN-FR 192
 - WAN-NEA 86
 - WAN-NX25 110
 - WAN-X25 150, 153
 - X.32 dialing 207
- NTP 58
- NTP, see null transport protocol
- ntpdisp 162
- ntpicdt 165
- NUI, see Network User Identification
- null transport protocol 56, 58, 144
- null transport provider 174
- number
 - multilink 79
- O**
- object
 - create (FSS) 269
 - delete (FSS) 269
 - retrieve (FSS) 270
 - set (FSS) 269
- object class
 - FACIL 273
 - GNSAP 279
 - LOCNSAP 280
 - NSAP 281
 - SNPAROUTES 283
- one-way channel 33
- operand
 - default value 224
 - mandatory (KOGS) 224
 - optional (KOGS) 224
- operation
 - of CCP-WAN 59
- optimize connectivity 44
- option 67
- OPTIONS 246
- OSI Reference Model 25
- OSI transport protocol 9
- P**
- packet 12
- packet assembly 15
- packet disassembly 15
- packet length 33, 240
 - in send direction 240
- packet level 28
 - function 30
- packet numbering 241
- packet sequence number 34
- Packet Switched Data Network 10, 11, 57

- packet switching
 - characteristics 11
- packet switching center 15, 16
 - local 16
- packet switching network 11
 - protocols 11
 - structure 15
- packet switching network nodes 16
- packet-mode data terminal equipment 17
- packet-oriented DTE 11
- PAKLE 240
- PAKLS 240
- PAKNUM 241
- parallel lines
 - bundled 23
- partner link address 259
- partner system
 - configure 59, 69
 - enter 59
 - enter (menu system) 71
 - enter (WAN-CONS) 136
 - enter (WAN-FR) 196
 - enter (WAN-NEA) 91
 - enter (WAN-NX25) 115
 - enter (WAN-X25) 160
 - enter (X.32 dialing) 217
- permanent virtual circuit 13, 30
- phone-nr 284
- PKANALN 247
- PLIDENT 248
- point-to-point connection 255
- point-to-point protocol 43
- POLLPAU 248
- port number 7
- PPP 43
- prepare trace
 - Etheral 327
 - Etheral (graphic) 330
 - tetheral (text) 332
- preset call number 24
- PRIDENT 260
- primary station 256
- processor line identification 248
- PROFIL 249
- profile
 - CCP-WAN-NEA 77
 - CCP-WAN-NX25 101
 - subnetwork 56
 - WAN-CONS 121
 - WAN-CONS with protocol T.70 123
 - WAN-FR 185
 - WAN-NX25 101
 - WAN-SDLC 173
 - WAN-X25 143
- program interface
 - ICMX 2, 155
 - XTI 2, 155
- protocol 24
 - frame relay- 36
 - SDLC 174
 - SNA 56
 - T.70 122
 - TCP/IP 56
 - transport 56
- protocol analyser 327
- protocol encapsulation 36, 41
- protocol monitoring period 249
- PRTIM2 250
- PRTIM3 250
- PRTIMER 249
- PSC 16
- PSC, see packet switching center
- PSDN 11
- PSDN, see Packet Switched Data Network
- PVC 13, 30
 - priority (frame relay) 41
 - without facilities (WAN-NX25) 118
- PVC number 39
- pvc-nr 285
- R**
- R20 241
- R22 241
- R23 241
- RCB 250

Index

- reassemble 28
 - Recommendation
 - X.21 27
 - X.21bis 27
 - remote network address
 - WAN-CONS 129
 - WAN-FR 192
 - WAN-NEA 86
 - WAN-NX25 110
 - WAN-X25 150, 153
 - X.32 dialing 207
 - remote subnetwork port
 - WAN-FR 193
 - X.32 dialing 208
 - REMSNPA
 - WAN-FR 193
 - X.32 dialing 208
 - restart 28, 62
 - retrieve
 - FSS object 270
 - retry counter
 - clear request 241
 - for restart request 241
 - reset request 241
 - REVCH 238
 - reverse charging 34, 238
 - reverse charging acceptance 34
 - RFC 1490 41
 - RNR packet 242
 - route
 - alternative route in another subnetwork 45
 - alternative route in same subnetwork 44
 - configuration 283
 - define (WAN-CONS) 130, 135
 - define (WAN-FR) 193, 196
 - define (WAN-NEA) 87, 90
 - define (WAN-NX25) 111, 114
 - define (WAN-X25) 150
 - define (X.32 dialing) 209, 215
 - defining (WAN-X25) 158
 - enter (menu system) 70
 - select from multiple GNSAP objects 279
 - router 18
 - routing
 - TCP/IP 43
 - routing information
 - entry 74
 - input 70
 - RR packet 242
 - RUF 251
 - RUFNUM 252
 - RUFPAUS 252
 - RUFWDH 252
- ## S
- SDLC 58
 - SDLC protocol 173
 - SDLC SBKA (address format) 178
 - secondary station 256
 - selection
 - automatic 24
 - manual 24
 - X.32 47
 - send direction
 - packet length 240
 - send pulse rate 246
 - set
 - FSS object 269
 - set (FSS action) 269
 - setup
 - dial up connection 251
 - dial-up connection AUTO 251
 - dial-up connection AUTO/ABG 251
 - dial-up connection AUTO/ANK 251
 - dial-up connection DIREKT 251
 - dial-up connection MANUELL 251
 - dial-up connection MANUELL/ABG 251
 - shell command
 - execute 314

- single packet
 - fast select 34
- SKANABG 252, 265
- SKANALN 253, 266
- SKANANK 254, 266
- SNA 58
- SNA application 143
 - via X.25 (WAN-X25) 167
- SNA communication 9
- SNA network 173
- SNA protocol 56
- SNA-XID exchange 173
- SNID address 70
- SNID, see subnet ID
- SNP
 - load 68
- SNPA address 70
- snpa-list 282
- SNPAROUTES 283
 - WAN-CONS 130
 - WAN-FR 193
 - WAN-NEA 87
 - WAN-NX25 111
 - WAN-X25 150, 154
 - X.32 dialing 209
- sockets application 155
- sof - switch off trace list 306
- software requirements 8
- son - switch on trace 308
- son - switch on trace list 308
- source file
 - KOGS 224
- standard window size 33
- standardization
 - protocols 24
- start
 - KOGS 262
- startup
 - of the Communications Controller 59
- station
 - primary 256
 - secondary 256
- Statistics list 321
- statistics list
 - using 324
- stop
 - network access software 302
- stop - deactivate network access software 302
- structure
 - packet switching network 15
- subnet 283
- subnet address 70
- subnet address type 284
 - WAN-CONS 130
 - WAN-FR 193
 - WAN-NX25 111
 - WAN-X25 154
 - X.32 dialing 209
- subnet connection
 - configure 62
 - local 62
- subnet ID 70, 283
 - define 261
 - WAN-CONS 130
 - WAN-FR 193
 - WAN-NEA 87
 - WAN-NX25 111
 - WAN-X25 150, 154
 - X.32 dialing 209
- subnet identification, see subnet ID
- subnet interface
 - PSDN 57
 - telephone 57
- subnet interface
 - CSDN 57
 - frame relay 58
- SUBNET objects 73
- subnet profile
 - administration 289
- subnetwork
 - alternative route 45

Index

- subnetwork address type
 - for a X.21 call number 261
 - for dedicated lines 261
 - for DTE in X.25 network 261
 - for frame relay_PVCs 262
 - for phone networks 262
 - FS_FR_PVC 262
 - HDLCPP 261
 - PT_ADR 262
 - WAN-NEA 87
 - X21_ADR 261
 - X25_ADR 261
- subnetwork connection 70
- subnetwork ID 344
- sub-network interface
 - configure (WAN-X25) 157
- subnetwork interface 56
 - configure (WAN-CONS) 134
 - configure (WAN-FR) 195
 - configure (WAN-NEA) 89
 - configure (WAN-SDLC) 179
 - configure (X.32 dialing) 213
 - define route 70
- subnetwork port
 - address 284
 - remote (WAN-FR) 193
 - remote (X.32 dialing) 208
- subnetwork profile 56
- SUBNID 262
- SVC 12, 30
 - with facilities (WAN-CONS) 138
 - with facilities (WAN-NX25) 117
 - without facilities (WAN-CONS) 137
- switch 39
- switched connection
 - clear 31
- switched virtual call 12, 30
- syntax
 - KOGS source file 225
 - macro call 225
- T**
 - T.70 57, 122, 123
 - T20 241
 - T21 241
 - T22 242
 - T24 242
 - T25 242
 - TCP/IP
 - via frame relay 197
 - via X.25 143
 - via X.25 (WAN-X25) 168
 - TCP/IP application 155, 194
 - TCP/IP protocol 56
 - TCP/IP routing 43
 - telephone 57
 - telephone network 56
 - terminal 17
 - tetheral
 - trace preparation (text) 332
 - throughput class
 - agreement 35
 - TNS parameter
 - WAN-CONS 132
 - WAN-FR 194
 - WAN-NEA 88
 - WAN-NX25 112
 - WAN-SDLC 178
 - WAN-X25 155
 - X.32 dialing 210
 - TNS, see Transport Name Service
 - tof - switch off trace transfer 310
 - ton - switch on trace list transfer 311
 - ton - trace lists - switch on list transfer 311
 - TP0/2 57, 123
 - TP0/2 (transport protocol) 56
 - TPAUSE 254

- trace list 303, 306
 - create 323
 - deactivate transfer 310
 - designation 304, 308, 310, 311
 - edit 303, 306
 - file name 305
 - ID 306
 - preparation 323
 - select 306
 - switch on 308
 - switch on list transfer 311
 - using 323
 - trace list transfer
 - switch on 311
 - trace point
 - meaning 303, 306, 308
 - switch off 306, 323
 - switch on 308, 323
 - traces
 - switching off 325
 - switching on 325
 - tracing
 - X.25 (line-specific) 326
 - TRANSDATA NEA (transport protocol) 56
 - TRANSIT-SERVER 9, 173
 - transmission
 - delay 243
 - transmission path 256
 - transmission speed 22, 255
 - TRANSPAC 257
 - Transport Name Service 59, 69
 - transport protocol 56
 - ISO class 0/2 56
 - NEA 8, 56
 - null (NTP) 56
 - OSI 9
 - TP0/2 56
 - transport service 56
 - Transport Service Provider 56
 - NEA 57
 - NTP 58
 - TP0/2 57
 - transport system application
 - configure 72
 - enter 72
 - enter (menu system) 72
 - enter (WAN-CONS) 136
 - enter (WAN-NEA) 92
 - enter (WAN-NX25) 116
 - enter (WAN-SDLC) 180
 - enter (WAN-X25) 161
 - enter (X.32 dialing) 218
 - TS application 349
 - TS application, see transport system application
 - TSP 317
 - Administration 317
 - Diagnostics 317
 - two-step dialing
 - to and from X.25 networks 47, 199
 - type 284
- ## U
- UEGSW 255
 - UEKONF 255
 - UEPROZ 255
 - UEUNB 256
 - UEWEG 256
 - user facilities
 - X.25 subnetwork interface 24
 - user group 32
 - bilaterally closed 32
 - closed 32, 34
 - user interface
 - character-oriented (CMXCUI) 2
- ## V
- V.24 interface 27
 - V24DEF 258
 - Van-Jacobsen header compression 274
 - version-specific dependency 8
 - virtual channel 30
 - virtual connection 11, 12, 13
 - connection
 - virtual 18

VUEZEIT 258

W

WA3SBKA (address format) 155

WAN connection 59, 63

WAN type 10

WAN, see wide area network

WAN3SBKA (address format) 211

WAN-CONS 57, 121

 alternative network port 141

 dedicated line (T.70) 139

 dial-up line (T.70) 140

 functionality 121

 protocols 123

 SVC with facilities 138

 SVC without facilities 137

WAN-FR 58, 185

 functionality 185

 protocols 188

 TCP/IP 197

WAN-MULTI 56

WAN-NEA 57, 77

 dedicated line, balanced 93

 dedicated line, unbalanced, point-to-point 98

 dial-up line, remote dialing 95

 multipoint secondary 99

 protocols 78

WANNEA (address format) 88, 112, 210

WAN-NX25 57, 101

 functionality 101

 protocols 102

 PVC without facilities 118

 SVC with facilities 117

WANSBKA (address format) 132, 211

WAN-SDLC 58, 173

 dedicated line 181

 dial-up line 182

 direct link 183

 functionality 173

 protocol 174

WAN-X25 58, 143

 functionality 143

 protocols 144

 SNA application 167

 TCP/IP 168

 X.25 application 167

WDHZAEL 258

wide area network 10

WINDE 242

window size 33, 35

WINDS 243

X

X.21 27

X.21 interface 27

X.21 network 56

X.21 Recommendation 27

X.21bis 27

X.21bis interface 27

X.21bis Recommendation 27

X.25 10, 11, 25, 26, 27, 57, 123

 protocol tracing (line-specific) 326

X.25 access

 with X.32 dialing 204

X.25 application 143

 via X.25 (WAN-X25) 167

X.25 concepts 27

X.25 connection

 loading test configuration 337

 setting up test configuration 337

 testing 333

 testing connection requests 333

 testing data transfer 333

X.25 facilities 32

X.25 interface 27, 237

X.25 network 56

 optional features 32

X.25 networks

 two-step dialing 47, 199

X.25 partner

 facilities (FSS) 169

X.25 profiles

 user facilities 25

X.25 protocol partner 17

- X.25 subnetwork interface
 - user facilities 24
- X.29 58
- X.31 26
- X.32 47
- X.32 dial-in 49
- X.32 dialing 199
 - addressing 48
 - charges 49
 - functionality 48
 - profiles 50
 - requirements 47
 - TSPs 50
 - with WAN-NEA 219
 - X.25 access 204
- X.32 dial-out 49, 204
- X.32 selection 47
- X.32-dial in 204
- X.75 25, 26
- X21DEF 258
- x25chk 333
- x25conf 337
- x25-description 204, 264
- x25snoop - execute line-specific X.25
 - protocol tracing 326
- x32-phone-nr 286
- XEND 228, 237
- XFACI 228, 237
 - AKFACI operand 238
 - DTEADCA operand 239
 - FACIL operand 240
 - NUI operand 240
 - PAKLE operand 240
 - PAKLS operand 240
 - PAKNUM operand 241
 - R20 operand 241
 - R22 operand 241
 - R23 operand 241
 - T20 operand 241
 - T21 operand 241
 - T22 operand 242
 - T24 operand 242
 - T25 operand 242
 - WINDE operand 242
 - WINDS operand 243
- XID exchange
 - define 259
 - SNA 173
- XLTNG 228, 243
 - CTIMER operand 243
 - DTEADR operand 243
 - DUETYP operand 244
 - FACIL operand 244, 245
 - FRMRANZ operand 245
 - LPUFADR operand 245
 - MAXIFL operand 245
 - MLNK operand 245
 - MODE operand 245
 - MODTAKT operand 246
 - NRZI operand 246
 - OPTIONS operand 246
 - PKANALN operand 247
 - PROFIL operand 249
 - RCB operand 250
 - RUF operand 251
 - RUFWDH operand 252
 - SKANABG operand 252
 - SKANALN operand 253
 - SKANANK operand 254
 - TPAUSE operand 254
 - UEGSW operand 255
 - UEKONF operand 255
 - UEPROZ operand 255
 - UEUNB operand 256
 - UEWEG operand 256
 - V24DEF operand 258
 - VUEZEIT operand 258
 - X21DEF operand 258
- XLTNG operands
 - PLIDENT 248
 - POLLPAU 248
 - PRTIM2 250
 - PRTIM3 250
 - PRTIMER 249
 - RUFPAUS 252
 - WDHZAEL 258

Index

- XPRO 228, 259
 - LINKADR operand 259
 - PRIDENT operand 260
- XPRO operands
 - LINKADR 259
 - RUFNUM 252
- XSNID 228, 261
 - ADRTYP operand 261
 - SUBNID operand 262
- XSYSP 228, 262
- XTI (program interface) 2, 155
- XZSTW 204, 228, 263
 - DTEADR operand 263
 - FACIL operand 263
 - LPUFADR operand 263
 - NAME operand 264
 - NETZTYP operand 264
 - operands 235
 - SKANABG operand 265
 - SKANALN operand 266
 - SKANANK operand 266

Fujitsu Siemens Computers GmbH
User Documentation
81730 München
Germany

Comments
Suggestions
Corrections

Fax: 0700 / 372 00000

email: manuals@fujitsu-siemens.com
<http://manuals.fujitsu-siemens.com>

Submitted by

Comments on CMX/CCP V6.0
WAN Communication



Fujitsu Siemens Computers GmbH
User Documentation
81730 München
Germany

Comments
Suggestions
Corrections

Fax: 0700 / 372 00000

email: manuals@fujitsu-siemens.com
<http://manuals.fujitsu-siemens.com>

Submitted by

Comments on CMX/CCP V6.0
WAN Communication





Information on this document

On April 1, 2009, Fujitsu became the sole owner of Fujitsu Siemens Computers. This new subsidiary of Fujitsu has been renamed Fujitsu Technology Solutions.

This document from the document archive refers to a product version which was released a considerable time ago or which is no longer marketed.

Please note that all company references and copyrights in this document have been legally transferred to Fujitsu Technology Solutions.

Contact and support addresses will now be offered by Fujitsu Technology Solutions and have the format ...@ts.fujitsu.com.

The Internet pages of Fujitsu Technology Solutions are available at [http://ts.fujitsu.com/...](http://ts.fujitsu.com/) and the user documentation at <http://manuals.ts.fujitsu.com>.

Copyright Fujitsu Technology Solutions, 2009

Hinweise zum vorliegenden Dokument

Zum 1. April 2009 ist Fujitsu Siemens Computers in den alleinigen Besitz von Fujitsu übergegangen. Diese neue Tochtergesellschaft von Fujitsu trägt seitdem den Namen Fujitsu Technology Solutions.

Das vorliegende Dokument aus dem Dokumentenarchiv bezieht sich auf eine bereits vor längerer Zeit freigegebene oder nicht mehr im Vertrieb befindliche Produktversion.

Bitte beachten Sie, dass alle Firmenbezüge und Copyrights im vorliegenden Dokument rechtlich auf Fujitsu Technology Solutions übergegangen sind.

Kontakt- und Supportadressen werden nun von Fujitsu Technology Solutions angeboten und haben die Form ...@ts.fujitsu.com.

Die Internetseiten von Fujitsu Technology Solutions finden Sie unter [http://de.ts.fujitsu.com/...](http://de.ts.fujitsu.com/), und unter <http://manuals.ts.fujitsu.com> finden Sie die Benutzerdokumentation.

Copyright Fujitsu Technology Solutions, 2009