

Fujitsu Server BS2000 SE Series

# Additive Components

Operating Manual

Valid for:

SE700(B) / SE500(B) / SE300(B) (basic software V6.2A and higher)

SE710 / SE310 (basic software V6.3A and higher)

Edition December 2019

---

## Comments... Suggestions... Corrections...

The User Documentation Department would like to know your opinion on this manual. Your feedback helps us to optimize our documentation to suit your individual needs.

Feel free to send us your comments by e-mail to: [bs2000services@ts.fujitsu.com](mailto:bs2000services@ts.fujitsu.com).

## Certified documentation according to DIN EN ISO 9001:2015

To ensure a consistently high quality standard and user-friendliness, this documentation was created to meet the regulations of a quality management system which complies with the requirements of the standard DIN EN ISO 9001:2015.

## Copyright and Trademarks

Copyright © 2020 Fujitsu Technology Solutions GmbH.

All rights reserved.

Delivery subject to availability; right of technical modifications reserved.

All hardware and software names used are trademarks of their respective manufacturers.

The Xen® mark is a trademark of Citrix Systems, Inc., which manages the mark on behalf of the Xen open source community. The Xen® mark is registered with the U.S. Patent and Trademark Office, and may also be registered in other countries.

Novell and SUSE are registered brands of Novell, Inc. in the USA and other countries.

Linux is a registered brand of Linus Torvalds.

Windows® is a registered trademark of Microsoft Corporation.

The Linux-based basic software M2000, X2000, and HNC which is installed on the Management Unit, Server Unit x86, and HNC contains Open Source Software. The licenses for this can be found in the LICENSES directory on the relevant installation DVD.

# Table of Contents

- Additive Components** ..... **5**
- 1 Introduction** ..... **6**
- 2 Application Unit** ..... **7**
  - 2.1 Application Unit PY (SE AU PY)** ..... **9**
    - 2.1.1 Application Unit AU25 ..... 10
    - 2.1.2 Application Unit AU47 ..... 11
      - 2.1.2.1 Front of the Application Unit ..... 12
      - 2.1.2.2 Rear of the Application Unit ..... 20
  - 2.2 Application Unit PQ (SE AU PQ)** ..... **24**
  - 2.3 Switching an Application Unit on/off** ..... **25**
  - 2.4 Operating system and other software** ..... **26**
  - 2.5 System operation** ..... **27**
- 3 Net Unit** ..... **28**
  - 3.1 Port extension** ..... **29**
  - 3.2 10 Gb Net Unit extension** ..... **30**
    - 3.2.1 Front ..... 31
    - 3.2.2 Rear panel ..... 32
    - 3.2.3 Numbering slots and Ethernet ports ..... 33
    - 3.2.4 Operating the switch ..... 34
      - 3.2.4.1 LED activity interpretation ..... 35
      - 3.2.4.2 Front panel LEDs ..... 36
      - 3.2.4.3 Rear panel LEDs ..... 37
      - 3.2.4.4 LED patterns ..... 38
    - 3.2.5 Cabling in the Net Unit ..... 42
- 4 Periphery** ..... **45**
  - 4.1 ETERNUS JX40 (S2) disk storage system** ..... **47**
    - 4.1.1 Indicator elements (front) ..... 48
    - 4.1.2 Operating and indicator elements (rear) ..... 50
    - 4.1.3 Problem Solutions and Tips ..... 52
  - 4.2 ETERNUS LT40 S2 tape library** ..... **53**
    - 4.2.1 Front panel ..... 55
    - 4.2.2 Rear panel ..... 56
    - 4.2.3 Operating the tape library ..... 57
      - 4.2.3.1 Operating panel on the device ..... 58
      - 4.2.3.2 Remote Management Unit (RMU) ..... 63
    - 4.2.4 Magazines ..... 65
      - 4.2.4.1 Removing and replacing a magazine using the OCP ..... 66

4.2.4.2 Removing and replacing a magazine using the RMU .....	67
4.2.4.3 Inserting tape cartridges into a magazine .....	68
4.2.4.4 Mailslots .....	69
4.2.5 LTO tape cartridges .....	70
4.2.6 Working with the tape library .....	72
4.2.6.1 Modes of the tape library .....	73
4.2.6.2 Device settings .....	74
4.2.7 Error handling .....	77
4.2.7.1 Removing stuck tapes from slots .....	80
4.2.7.2 Tape library error codes .....	83
<b>4.3 ETERNUS DX100 S4 disk storage system .....</b>	<b>84</b>
<b>4.4 ETERNUS LT140 tape library .....</b>	<b>85</b>
<b>5 Related publications .....</b>	<b>86</b>

# Additive Components

## 1 Introduction

The FUJITSU Server BS2000 SE Series unites the existing server lines S servers and SQ servers in the server line SE servers.

Depending on requirements, an SE server contains all the system components needed for operation as an overall application:

- /390-based BS2000 Server Unit
- x86-based Server Units with BS2000 guest systems, SU300 also with Linux or Windows guest systems as an option
- x86-based Application Units for operation under Linux, Windows, VMware or other hypervisors
- Shareable tape and disk periphery
- A high-speed, server-internal infrastructure to connect the components with each other and with the customer's IP or FC network.

### **Information on the hardware lifecycle of the FUJITSU Server BS2000 SE Series (Changes since the last edition of the manual)**

With the hardware lifecycle of the SE Series, the hardware basis for the Server Unit x86, the Management Unit and the HNC has been renewed several times. If the following generations are not identified by their own designations (e.g. SU300 -> SU300B -> SU310), the generations are identified by a subsequent Mx with x = 1,2,3,...: MU M2, MU M3, HNC M2, HNC M3 etc. The generation M2 is supported as of SE V6.2A, the generation M3 as of version 6.3A04.

The changes in the manuals are mainly due to these new hardware lifecycle generation models. Any differences to the previous models regarding structure and operation are described in detail.

### **Information on using the manual**

The Operating Manual consists of a number of modules and describes the features and hardware components of the FUJITSU Server BS2000 of the SE Series. Users should read the operating manuals carefully in order to obtain optimal performance from the SE server.

This manual describes the optional hardware components such as Application Unit, redundant Net Unit and peripheral devices, thus complementing the Basic Operating Manual [1]. You will find a comprehensive introductory chapter in the Basic Operating Manual. The chapters "Important notes" chapter on SE server operation and "Environmental protection and service" are contained only in the Basic Operating Manual.

In the following, abbreviations are used to describe the SE server models and their components. These are explained in the introduction to the Basic Operating Manual [1] in the section "Models, Names, Abbreviations".

## 2 Application Unit

In addition to the Server Unit, up to 32 autonomous high-end x86-64 servers, which are known as Application Units, can also be installed and operated in the rack of the SE server.

Application Units are particularly suitable for important corporate applications. They offer a high degree of data security and availability through highly-developed hardware and software components. Their structure (one to eight Intel processors of the XEON family) and their scalability enable them to be employed for a large number of customer applications, e.g. for medium-sized or large databases, for ERP systems and for subapplications which interwork with a BS2000 application on the Server Unit.

In comparison to guest systems on XenVMs in an SU x86, further operating systems can be operated on the Application Unit, and the selection of configured components is greater. The operating systems and the customer applications on the Application Unit run independently of the Server Unit.

Various operating systems and hypervisor systems (for virtualization) can be used for Application Units, e.g.:

- SUSE Linux Enterprise Server 12
- Red Hat Enterprise Linux 7 and 8
- VMware vSphere® ESXi 6.5 and 6.7
- Microsoft Windows Server 2016 and 2019
- Microsoft Windows Hyper-V Server 2016 and 2019
- Oracle LINUX 7.x
- Oracle VM Server 3.4

The list of currently supported operating systems and hypervisor systems can be found in the Release Notice for M2000 available on the manual server (<http://bs2manuals.ts.fujitsu.com>). The use of operating systems or hypervisor systems depends on the series and model of the application unit. For further details or if you want to use other operating systems or virtualization techniques, please contact the Customer Support.

It is the responsibility of the customer to configure the Application Units, and also to install and operate his/her own software on the Application Units, see the "Operation and Administration" manual [5].

Application Units are integrated into the service concept of the SE server, e.g. into remote service via the MU and into administration with the SE Manager. The following functions are offered for Application Units in the SE Manager:

- Status display of the Application Unit
- Display and configuration of the links to the web interfaces of the applications on the Application Unit
- Operation of the Application Unit and the AU-VMs
- Remote powering on of the Application Units using the iRMC
- Integration into AIS Connect (remote service)
- Storage Management functions via the add-on pack StorMan

Detailed information on this subject is provided in the "Operation and Administration" manual [5].

An Application Unit occupies 1 to 10 height units (HUs) in the rack, depending on the model. Up to 32 Application Units can be installed and operated in the rack or extension rack.

Depending on the hardware base, Application Units differ as follows:

- **Application Unit PY** refers to all PRIMERGY based AUs (e.g. the AU20 or AU47 hardware models).
- **Application Unit PQ** refers to all PRIMEQUEST based AUs (e.g. the AU87 or DBU87 hardware models).

This section covers the following topics:

- [Application Unit PY \(SE AU PY\)](#)
  - [Application Unit AU25](#)
  - [Application Unit AU47](#)
    - [Front of the Application Unit](#)
    - [Rear of the Application Unit](#)
- [Application Unit PQ \(SE AU PQ\)](#)
- [Switching an Application Unit on/off](#)
- [Operating system and other software](#)
- [System operation](#)



## 2.1 Application Unit PY (SE AU PY)

The Application Unit PY (SE AU PY) are based on the different models of the FUJITSU Server PRIMERGY series.

This section covers the following topics:

- Application Unit AU25
- Application Unit AU47
  - Front of the Application Unit
  - Rear of the Application Unit

### 2.1.1 Application Unit AU25

AU25s require 1 or 2 height units in the rack. AU25s are set up on the same system unit as the PRIMERGY servers RX2530/RX2540 M<x>. Differences in the basic units exist to permit integration of the Application Units into the SE server and to enhance the SE server's redundancy features.

In the event of questions, e.g. regarding application compatibility, the information for the PRIMERGY servers RX2530/RX2540 M<x> also applies for the Application Units of the SE server.

Security functions in the BIOS setup and on the system board protect the data against manipulation. Information on the security functions is provided in the manual "BIOS Setup Utility for FUJITSU Server PRIMERGY RX25yy M<x>" on the Manual Server (<http://manuals.ts.fujitsu.com>):

- > Go to *x86 Servers* -> *PRIMERGY Servers*, select *PRIMERGY RX Servers* and then *RX 2530 Series* respectively *RX 2540 Series*.

**i** With the release of Service Pack 1 of SE V6.2A, AU25 M4 is also released after AU25 M1. With SE V6.3A, AU25 M4 on the basis of PRIMERGY RX2540 M4 is released as well as AU2540 M5 on the basis of PRIMERGY RX2540 M5.

### Features

AU25s based on PRIMERGY RX2530 contain one or two Intel XEON processors, have a storage capacity of up to 1.5 TB and offer four PCI express slots.

AU25s based on PRIMERGY RX2540 contain one or two Intel XEON processors, have a storage capacity of up to 3 TB and offer - depending on the configuration - up to eight PCI express slots.

Detailed information on the various hardware components and interfaces of the Application Units is provided in the data sheet "FUJITSU Server BS2000 SE Series". See the product site for the relevant server at <http://www.fujitsu.com/uk>:

- > Go to *Products* -> *Servers* -> *BS2000* -> FUJITSU Server *BS2000* and select SE700, SE500 or SE300.

## 2.1.2 Application Unit AU47

AU47s require 2 resp. 4 height units in the rack. AU47s are set up on the same system unit as the PRIMERGY servers RX4770 M<x> and use the same system board. Differences in the basic units exist to permit integration of the Application Units into the SE server and to enhance the SE server's redundancy features.

In the event of questions, e.g. regarding application compatibility, the information for the PRIMERGY servers RX4770 M<x> also applies for the Application Units of the SE server.

Security functions in the BIOS setup and on the system board protect the data against manipulation. Information on the security functions is provided in the manual "D<nnnn> BIOS Setup Utility for FUJITSU Server PRIMERGY RX4770 M<x>" on the general FUJITSU manual server (<http://manuals.ts.fujitsu.com>):

- > Go to *x86 Servers* -> *PRIMERGY Servers*, select *PRIMERGY RX Servers*, and then the model *PRIMERGY RX4770 M<x>* under *RX 4770 Series*.

### Features

Application Units contain two or four Intel XEON processors, have a storage capacity of up to 15 TB and offer up to ten PCI express slots.

Detailed information on the various hardware components and interfaces of the Application Units is provided in the data sheet "FUJITSU Server BS2000 SE Series". See the product site for the relevant server at <http://www.fujitsu.com/uk>:

- > Go to *Products* -> *Servers* -> *BS2000* -> FUJITSU Server *BS2000* and select SE700/710, SE500 or SE300 /310.

The following sections describe front and rear of the Application Unit:

- [Front of the Application Unit](#)
- [Rear of the Application Unit](#)

### 2.1.2.1 Front of the Application Unit



Figure 1: Application Unit AU47 M3 (front)

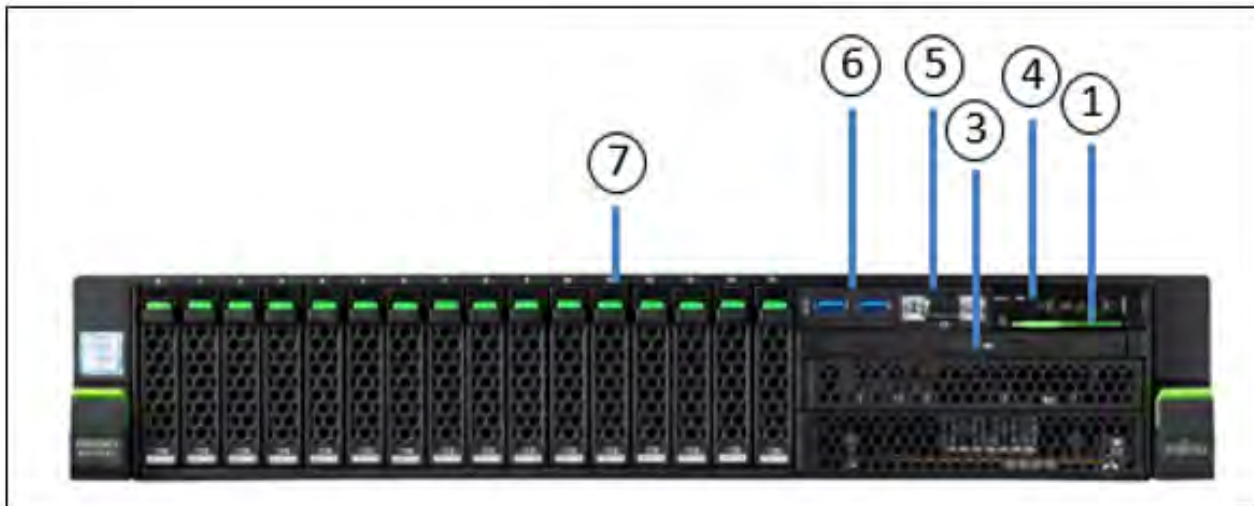

Figure 2: Application Unit AU47 M5 (front)

No.	Meaning
1	ID card (green)
2	ServerView Local Service Display (AU47 M3 only)
3	Optical drive activity indicator
4	Operator control panel (for further details see <a href="#">figure 3/4</a> )
5	Video port
6	3x resp. 2x USB ports

7	HDD indicators; 8 slots for 2.5" HDDs
8	AU47 M3 only: SSD indicators; 4 slots for SSDs

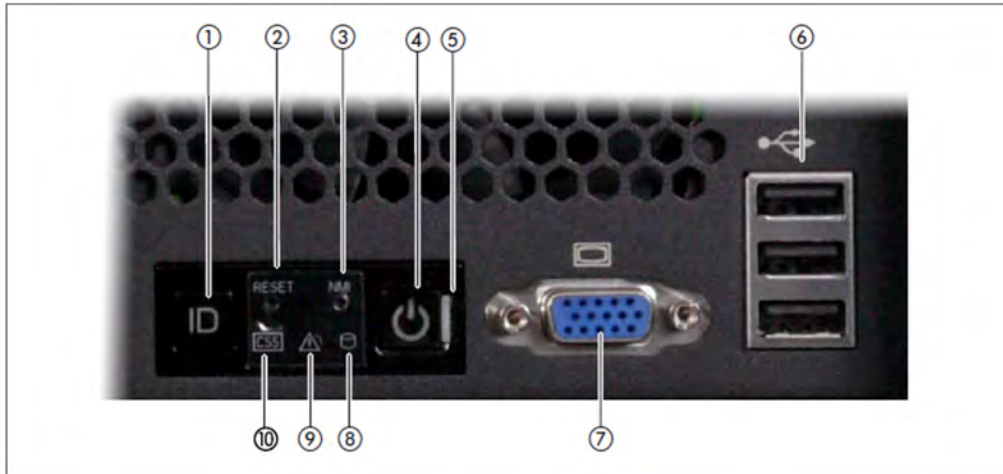

Figure 3: AU47 M3 (front) - Detailed view: Operator control panel

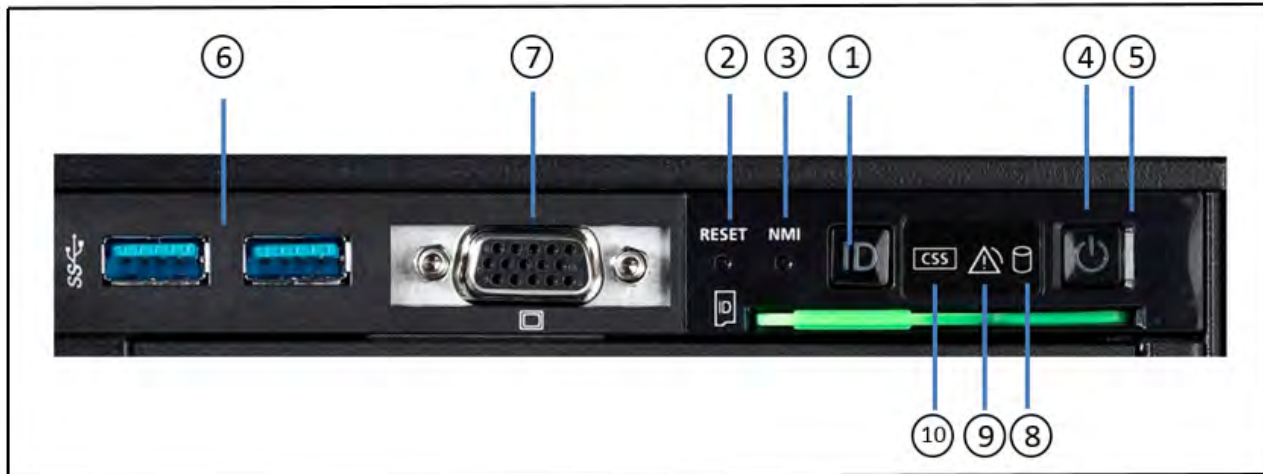

Figure 4: AU47 M5 (front) - Detailed view: Operator control panel

No.	Meaning
1	ID button / ID indicator
2	Reset button
3	NMI button
4	On/Off button / Status indicator
5	Status indicator (power cable connected)

6	3x resp. 2x USB ports
7	Video port
8	HDD/SSD activity indicator
9	Global error indicator
10	CSS indicator

## **ID card**



You can pull the ID card (see [figure 1/2](#)) out and push it in again as far as it will go.

The ID card contains various system information, e.g. product name, serial number, MAC addresses and DNS name.

## Controls

Control	Meaning
<b>ID</b>	<p>Identification (ID) button</p> <p>Lights up (blue) on the front and on the rear of the server when the ID button is pressed. The two ID indicators are synchronized.</p>
	<p>On/Off switch</p> <p>When the Application Unit is switched off, it is switched on again by pressing the On/Off switch once.</p> <p>When the Application Unit is in operation, it is switched off by pressing the On/Off switch once.</p> <div data-bbox="272 632 1455 764" style="background-color: #fff9c4; padding: 10px;"> <p><b>! CAUTION!</b></p> <p>Possible loss of data!</p> </div> <div data-bbox="272 793 1455 940" style="background-color: #e1eef6; padding: 10px;"> <p><b>i</b> The On/Off switch does not disconnect the server from the voltage grid. To disconnect from the mains completely, remove the power plugs. These buttons may only be used by Customer Support.</p> </div>
<b>RST or RESET</b>	<p>Reset button</p> <p>Pressing the Reset button reboots the Application Unit.</p> <div data-bbox="272 1115 1455 1247" style="background-color: #fff9c4; padding: 10px;"> <p><b>! CAUTION!</b></p> <p>Possible loss of data!</p> </div>
<b>NMI</b>	<p>NMI button</p> <div data-bbox="272 1360 1455 1493" style="background-color: #fff9c4; padding: 10px;"> <p><b>! CAUTION!</b></p> <p>Do not press! Possible loss of data! The NMI button may only be used by Customer Support.</p> </div>

## Indicators on the operator control panel

Indicator	Meaning
ID	<p><b>ID indicator (blue)</b></p> <p>Lights up blue when the Application Unit has been selected by pressing the ID button. To deactivate, press the button again.</p> <p>The ID indicator can also be activated via the ServerView Operations Manager and the iRMC Web GUI, and the status is reported to the ServerView Operations Manager and the iRMC.</p>
	<p><b>Status indicator (green)</b></p> <p><b>Does not light up</b> when the Application Unit is switched off but is connected to the power supply (power cable connected).</p> <p><b>Lights up green</b> during the power up delay and in normal system operation (S0).</p> <p><b>Status indicator (power cable connected)( green)</b> on the right-hand side of the On/Off switch</p> <p><b>Does not light up</b> in the following cases:</p> <ul style="list-style-type: none"> <li>• The Application Unit is not connected to the power source</li> <li>• The Application Unit Unit is switched on and operating normally (S0)</li> </ul> <p><b>Lights up green</b> when one of the following cases occurs:</p> <ul style="list-style-type: none"> <li>• The Application Unit is switched off but connected to the power supply (power cable connected)</li> <li>• The Application Unit is switched on but is in the power up delay</li> </ul> <div style="background-color: #e6f2ff; padding: 10px; margin-top: 10px;"> <p><b>i</b> After the Application Unit has been connected to the power source, it takes approximately 60 seconds until the Application Unit has entered standby mode.</p> </div>
	<p><b>HDD activity indicator (green)</b></p> <p><b>Lights up green</b> when an internal hard disk drive or a solid state drive is being accessed.</p>



**Global error indicator (yellow)**

**Lights up yellow** when a prefailure event was detected which requires Customer Support to become active (by way of precaution).

**Flashes yellow** when an error was detected which requires Customer Support to become active.

**Does not light up** when no critical event has occurred.

If the event is still acute after a power failure, the indicator is activated after the restart.

The indicator also lights up in standby mode.

You can obtain detailed information on the error cases displayed from the System Event Log (SEL), on the ServerView Local Service Display, in the ServerView Operations Manager or on the web interface of the iRMC.

**Indicators on the operable drives/components***Optical drive activity indicator*

Lights up green when the storage medium is accessed.

*ServerView Local Service Display (AU47 M3 only)*

A tray mechanism enables you to pull the ServerView Local Service Display out of the computer housing to read information. Press the front of the module to release the lock.

You can also swing the ServerView Local Service Display out of its normal position at an angle of 120°. This makes it easier to read the information when the server is located high up in the rack.

**! CAUTION!**

If a fault occurs, please contact Customer Support.

## Hard disks



Figure 5: Indicators on a hot-plug HDD module

No.	Meaning
1	<p>HDD BUSY (green)</p> <ul style="list-style-type: none"> <li>• Lights up: HDD in active phase (drive active, access to drive)</li> <li>• Does not light up: HDD inactive</li> </ul>
2	<p>HDD FAULT (orange)</p> <ul style="list-style-type: none"> <li>• Does not light up: No HDD error</li> <li>• Lights up:               <ul style="list-style-type: none"> <li>HDD Faulty or Rebuild Stopped (drive defective / needs replacing, a rebuild process was stopped or the slide-in module is not correctly inserted)</li> </ul> </li> <li>• Slow flashing: HDD Rebuild (the data is being restored after changing a hard disk drive)</li> </ul>

If a hard disk drive continuously indicates an error, the drive should be replaced by Customer Support as soon as possible. In this case call Customer Support.

## SSD indicator



Figure 6: Indicators on the SSD drives

No.	Meaning
1	<p>LED green</p> <p>BUSY</p> <ul style="list-style-type: none"> <li>• Lights up: SSD in active phase</li> <li>• Does not light up: SSD inactive</li> </ul>
2	<p>LED orange</p> <p>FAULT (orange) (in conjunction with a RAID controller)</p> <ul style="list-style-type: none"> <li>• Does not light up: No error</li> <li>• Lights up: Faulty or Rebuild Stopped (drive defective / needs replacing, a rebuild process was stopped or the slide-in module was not correctly inserted)</li> <li>• Slow flashing: Rebuild (the data is being restored after changing a drive)</li> <li>• Fast flashing: Identify</li> </ul>

### 2.1.2.2 Rear of the Application Unit

## Rear of the AU47 M3

### Global error indicator and CSS indicator

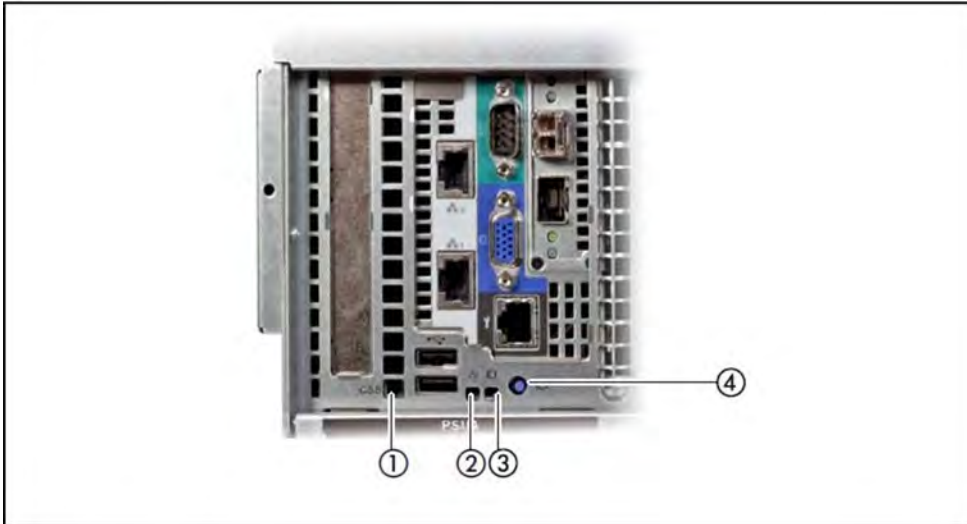

Figure 7: Global error indicator and CSS indicator, ID button and ID indicator

No.	Meaning
1	<p>CSS indicator (yellow)</p> <ul style="list-style-type: none"> <li>• <b>Lights up yellow</b> when a prefailure event was detected which requires Customer Support to become active (by way of precaution).</li> <li>• <b>Flashes yellow</b> when an error was detected which requires Customer Support to become active.</li> <li>• <b>Does not light up</b> when the Application Unit is OK.</li> </ul> <p>If the event is still acute after the Application Unit has been switched on/off, the indicator is activated after the restart.</p> <p>The indicator also lights up in standby mode.</p> <p>If the indicator flashes <b>yellow</b>, call Customer Support.</p>
2	<p>Global error indicator (yellow)</p> <ul style="list-style-type: none"> <li>• <b>Lights up yellow</b> when a prefailure event was detected which requires Customer Support to become active (by way of precaution).</li> <li>• <b>Flashes yellow</b> when an error was detected which requires Customer Support to become active.</li> <li>• <b>Does not light up</b> when no critical event has occurred.</li> </ul> <p>If the event is still acute after a power failure, the indicator is activated after the restart.</p> <p>The indicator also lights up in standby mode.</p> <p>If the indicator flashes <b>yellow</b>, call Customer Support.</p>

3	<p>ID indicator (blue)</p> <ul style="list-style-type: none"> <li>• <b>Lights up blue</b> when the Application Unit has been selected by pressing the ID button. Press the button again to deactivate it.</li> </ul> <p>The ID indicator can also be activated via the ServerView Operations Manager and the iRMC Web GUI, and the status can be reported to the ServerView Operations Manager and the iRMC.</p>
4	<p>ID button</p>

### LAN ports

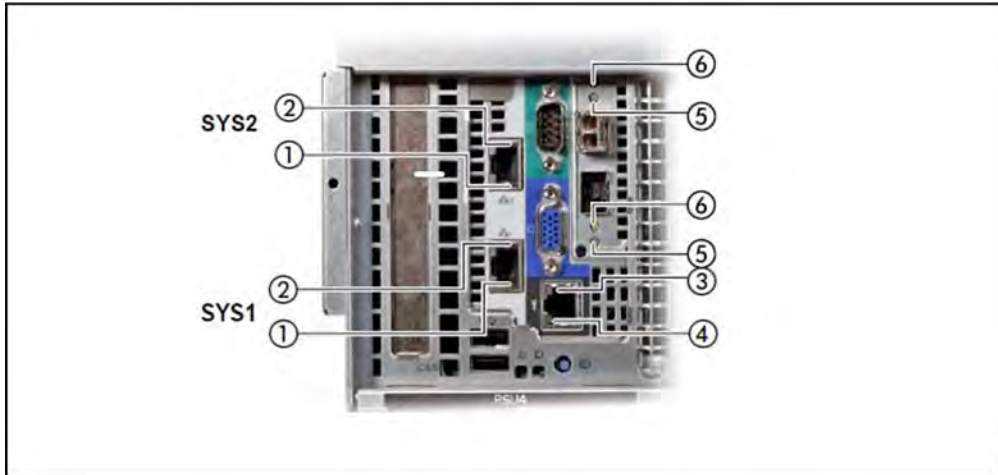

Figure 8: LAN ports on the Application Unit

No.	Meaning
1	<p>LAN link/transfer (System LAN port <b>SYS1</b> or <b>SYS2</b>)</p> <ul style="list-style-type: none"> <li>• <b>Lights up green</b> if a LAN connection exists.</li> <li>• <b>Does not light up</b> if no LAN connection exists.</li> <li>• <b>Flashes green</b> when a LAN transfer is in progress.</li> </ul>
2	<p>LAN speed (System LAN port <b>SYS1</b> or <b>SYS2</b>)</p> <ul style="list-style-type: none"> <li>• <b>Lights up yellow</b> for a LAN transfer rate of 1 Gbps.</li> </ul>
3	<p>LAN speed (unused port)</p>
4	<p>LAN link/transfer (unused port)</p>
5	<p>LAN speed (unused port)</p>
6	<p>LAN link/transfer (unused port)</p>

The MAC addresses entered on the green ID card refer to LAN #1 (SYS1) and #2 (SYS2). The MAC addresses of LAN ports #3 (not used) and #4 (not used) are then the next two MAC addresses in ascending order. The green ID card is located on the front of the Application Unit, see item 1 in [figure 1/2](#).

### Indicators on the power supply units

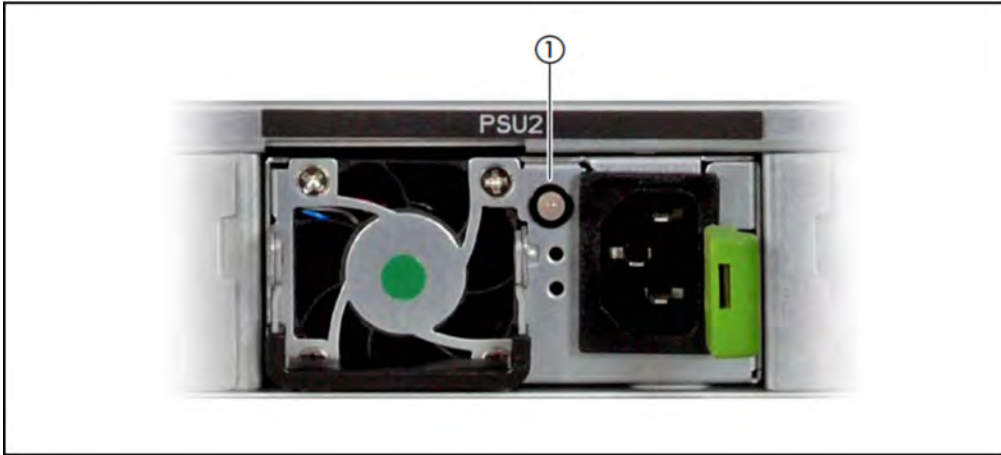

Figure 9: Indicators on the power supply units

No.	Meaning
1	<p>Power supply unit fault indicator and warning indicator:</p> <ul style="list-style-type: none"> <li>• <b>Lights up amber</b> when a critical event occurs (power supply unit switches off).</li> </ul> <p>Call Customer Support.</p>

### Assignment of the PCIe slots System LAN port

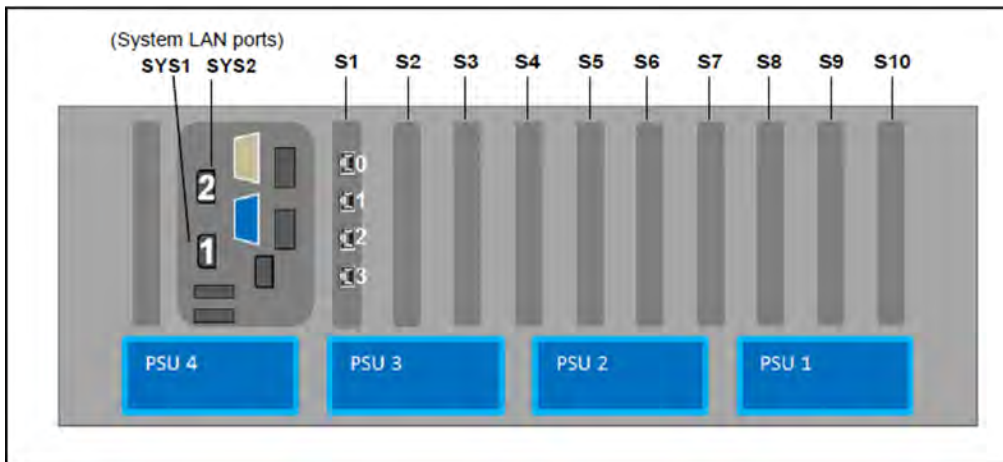

Figure 10: Principle of PCIe slot assignment at the rear of the device (AU47 M3)

The figure shows the PCIe slots of the AU:

- S1 is equipped with a 4-port LAN controller.
- Slots S2 through S10 are not equipped in the figure.

## Rear of the AU47 M5

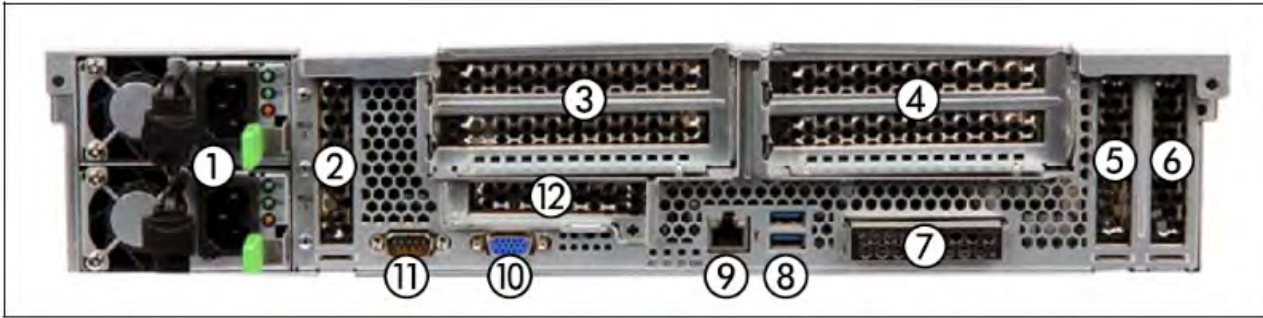

Figure 11: AU47 M5 (rear)

No.	Meaning
1	Power cord connections
2	PCI slot 8 (low profile)
3	PCI slot 7 (top), PCI slot 6 (bottom)
4	PCI slot 4 (top), PCI slot 3 (bottom)
5	PCI slot 2 (low profile)
6	PCI slot 1 (low profile)
7	Onboard LAN (SYS1/SYS2 connections)
8	2x USB 3.0 ports
9	iRMC Management LAN (SYS0)
10	VGA connection (to KVM adapter)
11	Serial connection (normally unused)
12	PCI slot 5 (low profile)

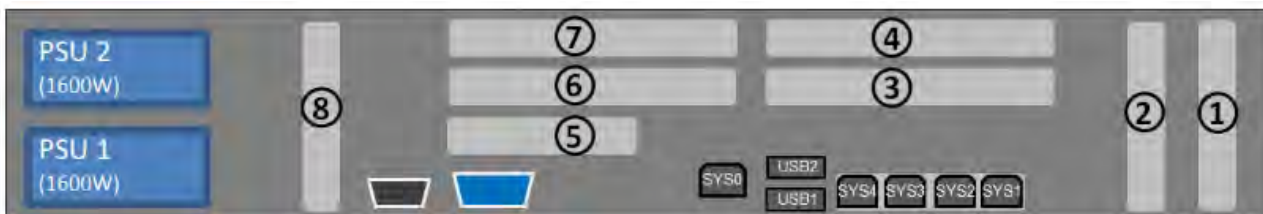

Figure 12: Principle of PCIe slot assignment at the rear of the device (AU47 M5)

## 2.2 Application Unit PQ (SE AU PQ)

The Application Unit PQ (SE AU PQ) is based on the different models of the FUJITSU Server PRIMEQUEST series, scalable with up to 8 sockets of the Intel XEON processor family.

- The AU87 and DBU87 models are based on the Primequest PQ2800E, which requires 10 height units in the rack.
- The AUQ38E or DBU38E models are based on the Primequest PQ3800E, which requires 7 height units in the rack.

The SE AU PQ combines the economic and flexibility benefits of x86 standards with mission-critical uptime features.

Isolated partitions enable high availability, where any hardware failure does not have any impact on other partitions. Partitioning enables also flexibility in using the hardware resources, as the partitions can be configured as needed for the workload of applications.

With the SE AU PQ are two high end usage scenarios possible:

- A general usage by customers: The customer determines the HW expansion of the AU, selects hypervisor and/or operating system(s) and is responsible for the operation itself. Monitoring and administration is carried out by the customer partly using the SE manager and partly with the tools of the software used.
- Usage as FUJITSU powered appliance: In a project-specific manner, the AU is configured by FUJITSU service employees in cooperation with the customer and the required SW configuration is defined. In the agreed framework, the required software will be installed before delivery and the AU will be administered by FUJITSU.

An example of this procedure is Oracle Database Server based on SE Application Units DBU87 and DBU38E (SE DBU).

The SE DBU offers an integrated, secure, mainframe-class appliance consisting of hardware and hypervisor software which can be used by the customer like an IaaS (Infrastructure as a Service): The customer is responsible for the operating system and database in the VMs on the DBU87, while FUJITSU delivers and configures everything, takes care of the licenses and maintains the hardware and hypervisor software during the whole lifecycle. Advantages for customers arise from the optimized cost efficiency, simplified operation and most current database versions on x86.

The original documentation of the PRIMEQUEST series applies for SE AU PQ. Note that some features of the PRIMEQUEST series may be released with restrictions for use on the SE server. You will find details of this in the Release Notice.

The manuals for the PRIMEQUEST series are available on the Manual Server (<http://manuals.ts.fujitsu.com>):

- > Go to *x86 Servers* -> *PRIMEQUEST Servers*.
- > Select *PRIMEQUEST 2000 Series* or *PRIMEQUEST 3000 Series* for a general description or hardware installation of the AU.
- > Or select *Software for PRIMEQUEST 2000*, for example for the administration of the AU.

 The manuals are only available in English.



## 2.3 Switching an Application Unit on/off

The Application Units are switched on and off individually or together with the other components of the SE server.

Information on switching on and starting the SE server and on switching it off and shutting it down is provided in the Basic Operating Manual [1], section "Switching the server on and off".

### ***Other On/Off options***

- SE Manager  
As administrator, AU administrator or privileged operator logged-in to the SE Manager, in the *Units* table under *Hardware* -> *Units* click the *Power off* icon by the desired Application Unit.  
Further information can be found in the Quick Guide [7].
- iRMC  
The iRMC offers various options for switching the Application Unit PY on and off, e.g. via the Power On Off page of the iRMC Web GUI.

**i** In the case of AU PQ, a Management Board is available instead of the iRMC. The AU can only be switched on/off at partition level.

- Timed power-on/off  
You can configure a timed power-on/off on an AU PY with the help of the iRMC.
- After power failure  
An Application Unit which is switched on reboots automatically following a power failure (depending on the settings in the BIOS setup or in the iRMC for AU PY resp. in the Management Board for AU PQ).
- Power Button Override  
The Application Unit can be switched off by pressing and holding down the On/Off button (for approximately 4 - 5 seconds).

**!** **CAUTION!**  
There is a risk that data may be lost!

- Wake up On LAN (WOL)  
An Application Unit is switched on by a command via the LAN (Magic Packet <sup>TM</sup>).

## 2.4 Operating system and other software

Application Units are supplied with the software ordered and are configured by Customer Support. If you require further software, please contact the Fujitsu Technology Solutions Sales department.

**i** The customized ISO image of FUJITSU must be used for vSphere Servers. This can be downloaded via <https://support.ts.fujitsu.com>.

You will find information on how to install software and how to configure the Application Unit in the “Operation and Administration” manual [5] and in the SE Manager's online help.

## 2.5 System operation

Server management is implemented using the ServerView Operations Manager supplied and the PDA (Prefailure Detection and Analysis) technology from Fujitsu Technology Solutions. PDA reports the threat of a system error or overload at an early stage, allowing preventive measures to be taken.

**i** You can download the ServerView software from the FUJITSU support site (download via <https://support.ts.fujitsu.com>).

You will find information on how Application Units are integrated into remote service in the “Operation and Administration” manual [5] and in the SE Manager’s online help.

## 3 Net Unit

This section covers the following topics:

- Port extension
- 10 Gb Net Unit extension
  - Front
  - Rear panel
  - Numbering slots and Ethernet ports
  - Operating the switch
    - LED activity interpretation
    - Front panel LEDs
    - Rear panel LEDs
    - LED patterns
  - Cabling in the Net Unit

### 3.1 Port extension

On SE700, SE500 and SE300 a redundantly designed Net Unit can be enhanced with a port extension.

In this case two redundant switches supplement the existing ports of the Net Unit to provide up to 96 redundant LAN ports.

The switches ICX 6450-24 and -48 resp. ICX 7450-48 of the "base" Net Unit are connected to those of the port extension with an FC cable.

**i** In multi-rack systems, the switches can be installed in different racks. On the SE300 the port extension is possible if the Net Unit is redundant in design.

## 3.2 10 Gb Net Unit extension

The "normal" Net Unit supports transmission speeds of up to 1 Gbps. The optional 10 Gb Net Unit extension enables high-speed internal and external network connections on the SE server with transmission speeds of up to 10 Gbps.

The 10 Gb Net Unit extension consists of a switch of the Brocade ICX 7750-48F model, and in a redundant design of two switches of this model. The 10 Gb Net Unit extension is possible for all SE server models (redundancy of the "normal" Net Unit is not required).

The ICX 7750-48F is connected to the "standard" Net Unit via Twinax-cables or standard optical cables. For a distance of more than 5 m between the two units, SFP+ connectors are required.

When the 10Gb Net Unit extension consists of two switches, both ICX 7750-48F switches are stacked via two QSFP (Quad Small Form-factor Pluggable) Twinax cables.

The SE Manager displays each ICX 7750-48F switch as a separate hardware unit in the *Hardware -> HW inventory* menu.

**i** When errors, malfunctions, etc. occur, please notify Customer Support.

This section covers the following topics:

- [Front](#)
- [Rear panel](#)
- [Numbering slots and Ethernet ports](#)
- [Operating the switch](#)
  - [LED activity interpretation](#)
  - [Front panel LEDs](#)
  - [Rear panel LEDs](#)
  - [LED patterns](#)
- [Cabling in the Net Unit](#)

### 3.2.1 Front

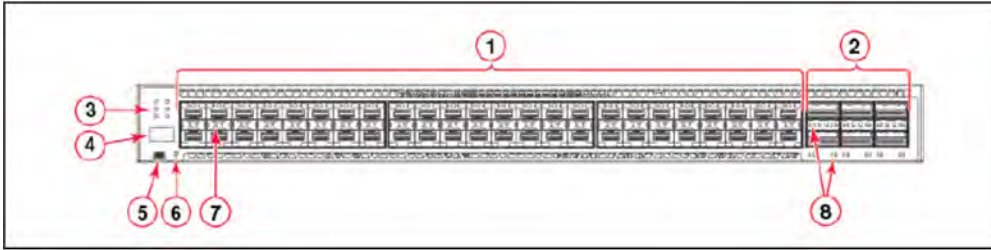

Figure 13: Net Unit (ICX 7750-48F) - front

***Explanation:***

- 1 SFP+ ports 1/1 - 1/48
- 2 QSFP+ ports XL2/1 - XL2/6
- 3 System LEDs
- 4 Stack unit ID display
- 5 Console port
- 6 Reset button
- 7 SFP+ port LEDs
- 8 QSFP+ port LEDs

### 3.2.2 Rear panel

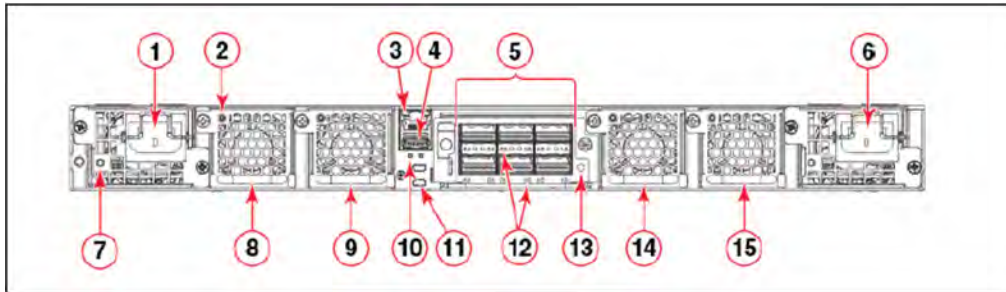

Figure 14: Net Unit (ICX 7750-48F) - rear

#### ***Explanation:***

- 1 Power supply unit 2
- 2 Fan tray LED
- 3 Management port
- 4 USB port
- 5 6-port 10/40 GbE QSFP+ expansion module
- 6 Power supply unit 1
- 7 Power supply unit 2 LED
- 8 Fan tray 4
- 9 Fan tray 3
- 10 UP and DN port LEDs
- 11 Control path UP and DN ports
- 12 QSFP+ module LEDs
- 13 Expansion module power LED
- 14 Fan tray 2
- 15 Fan tray 1



### 3.2.3 Numbering slots and Ethernet ports

Many CLI commands require users to enter port numbers as part of the command syntax, and many show command outputs display port numbers. The port numbers are entered and displayed in stack-unit/slot number/port number format.

The Brocade ICX 7750-48F switch contains the following slots and Ethernet ports:

- Slot 1 and Slot 2 are located on the front of the Brocade ICX 7750-48F device. Slot 1 contains 1/10 GbE SFP+ ports 1/1 through 1/48, with odd port numbers on the top row and port 1/1 on the left. Slot 2 contains 10/40 GbE QSFP+ ports XL2/1, XL2/3, and XL2/5 on the top row (left to right), and ports XL2/2, XL2/4, and XL2/6 on the bottom row (left to right).
- Slot 3 is located on the rear of the Brocade ICX 7750 switches and contains ports XL3/1, XL3/3, and XL3/5 on the top row (left to right) and ports XL3/2, XL3/4, and XL3/6 on the bottom row (left to right). These ports are 10/40 GbE QSFP+ ports.

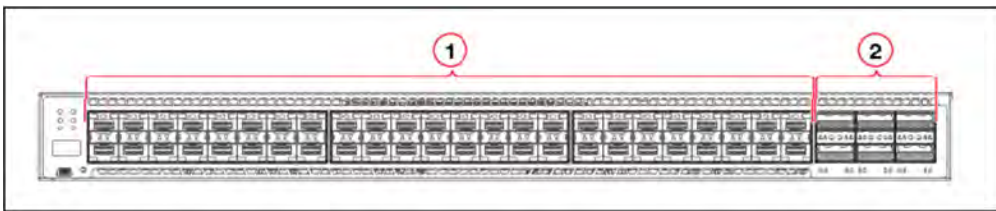

Figure 15: Net Unit (ICX 7750-48F) - Numbering of the slots (front)

#### ***Explanation:***

- 1 Slot 1
- 2 Slot 2

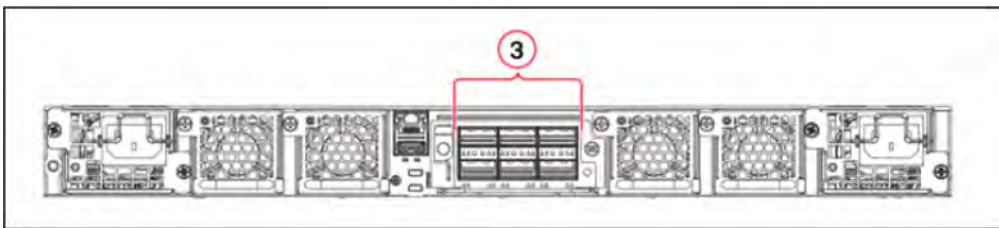

Figure 16: Net Unit (ICX 7750-48F) - Numbering of the slots (rear)

#### ***Explanation:***

- 3 Slot 3 (not employed; may not be used by the customer)

### 3.2.4 Operating the switch

This section covers the following topics:

- LED activity interpretation
- Front panel LEDs
- Rear panel LEDs
- LED patterns

### 3.2.4.1 LED activity interpretation

System activity and status can be determined through the activity of the LEDs on the switch.

There are three possible LED states: off (no light), a steady light, and a flashing light. Flashing lights may be slow, fast, or flickering.

The LED colors are either green or amber.

Sometimes, the LEDs flash either of the colors during boot, POST, or other diagnostic tests. This is normal; it does not indicate a problem unless the LEDs do not indicate a healthy state after all boot processes and diagnostic tests are complete.

### 3.2.4.2 Front panel LEDs

The Brocade ICX 7750-48F switch has the following LEDs on the front panel:

- Two power supply units (PSU) with bicolor status LEDs (green and amber) labeled PSU1 and PSU2
- One DIAG LED with bicolor status (green and amber) provides information about the diagnostic status
- One MS LED with bicolor status (green and amber) provides information about master/slave mode
- One HA LED with bicolor status (green and amber) provides information about highavailability mode
- One RDNT LED with bicolor status (green and amber) provides information about redundant mode
- Four bicolor status LEDs (green and amber) for each of the 26 QSFP+ ports that indicate the status of the ports in 40 GbE mode and 4x10 GbE breakout mode.

The [figure 17](#) shows the LEDs on the Brocade ICX 7750-48F front panel.

The up-arrow port status LEDs for the 10 GbE ports correspond to the upper, oddnumbered ports. The down-arrow port status LEDs correspond to the lower, evennumbered ports.

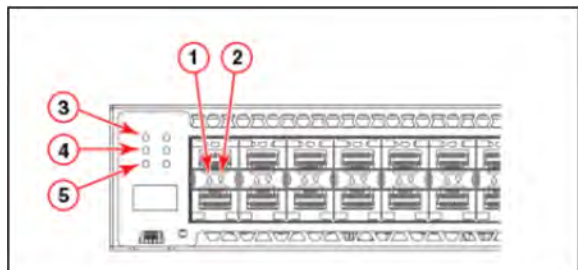

Figure 17: Net Unit (ICX 7750-48F) LEDs (front panel)

#### ***Explanation:***

- 1 Upper 1/10 GbE port LEDs
- 2 Lower 1/10 GbE port LEDs
- 3 PSU1 and PSU2 status LEDs  
(PSU1 corresponds to the right power supply slot on the rear panel and PSU2 corresponds to the left power supply slot, as viewed from the rear)
- 4 MS and DIAG status LEDs
- 5 HA and RDNT status LEDs

### 3.2.4.3 Rear panel LEDs

The Brocade ICX 7750-48F switch has the following LEDs on the rear panel:

- Two Management port status LEDs
- Two stack control path port LEDs
- Expansion module LEDs:
  - One Power LED bicolor status LED (green and amber)
  - Four bicolor status LEDs (green and amber) for each of the six QSFP+ ports that indicate the status of the ports in 40 GbE mode and 4x10 GbE breakout mode.
- Power supply LEDs: One status LED on each installed PSU (Power Supply Unit)
- Fan tray LEDs: One status LED on each installed fan tray

The [figure 14](#) shows the LEDs on the rear panel of the Brocade ICX 7750-48F.

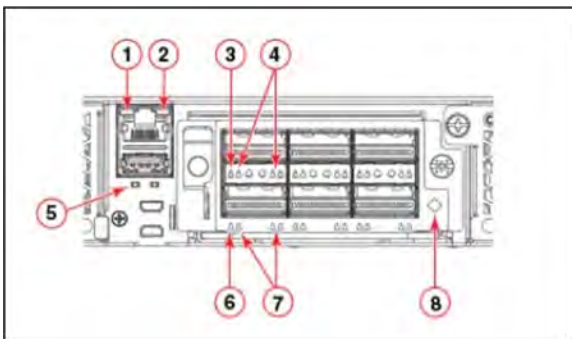

Figure 14: Net Unit (ICX 7750-48F) LEDs (rear panel)

#### ***Explanation:***

- 1 Management port 10/100 Mbps link/activity LEDs
- 2 Management port 1000 Mbps link/activity LEDs
- 3 Upper slot 40 GbE mode link/activity LED or 10 GbE mode lane 1 link/activity LEDs
- 4 Lower slot 10 GbE mode lanes 2, 3, and 4 link/activity LEDs
- 5 UP port (left) and DN port (right) link status LEDs
- 6 Lower slot 40 GbE mode link/activity LED or 10 GbE mode lane 1 link/activity LEDs
- 7 Lower slot 10 GbE mode lanes 2, 3, and 4 link/activity LEDs
- 8 Expansion module power LED

### 3.2.4.4 LED patterns

The following tables describe the Brocade ICX 7750-48F switch LED patterns.

#### ***PSU1 and PSU2 LEDs***

LED state	Status of hardware	Recommended action
Off (no light)	System is off or there is no power.	Verify the system is on and has completed booting.
Steady green	PSU is on and functioning properly.	No action required.
Steady amber	PSU is missing power or in a faulty state.	Verify that the PSU power cord is connected to a functioning power source. Replace the power supply.

#### ***DIAG LED***

LED state	Status of hardware	Recommended action
Off (no light)	Diagnostic is off.	No action required.
Blinking green	System self-diagnostic test is in progress.	No action required.
Steady green	System self-diagnostic test is successfully completed.	No action required.
Steady amber	System self-diagnostic test has detected a fault.	Contact support.

#### ***MS LED***

LED state	Status of hardware	Recommended action
Off (no light)	Stacking mode is enabled and the switch is a stack member, or the switch is operating in standalone mode.	No action required.
Steady green	Stacking mode is enabled and the switch is the stack master.	No action required.
Steady amber	Stacking mode is enabled and the switch is in slave mode.	No action required.

#### ***HA LED***

LED state	Status of hardware	Recommended action
Off (no light)	System high availability mode is disabled.	Verify stacking cables are connected.
Steady green	System is operating in high availability mode.	No action required.

Steady amber	System is preparing to operate in high availability mode.	No action required.
--------------	---	---------------------

***RDNT LED***

LED state	Status of hardware	Recommended action
Off (no light)	System does not have redundant fans or PSUs installed	No action required.
Steady green	System is operating in redundant mode.	No action required.
Steady amber	System has redundant fans and PSUs, but software has disabled redundant mode.	No action required.

***Management port left (10/100 Mbps) status LED***

LED state	Status of hardware	Recommended action
Off (no light)	Not cabled.	No action required.
Steady amber	No traffic being transmitted, but link is up.	No action required.
Blinking amber	There is traffic and packets are being transmitted or received.	No action required.

***Management port right (1000 Mbps) status LED***

LED state	Status of hardware	Recommended action
Off (no light)	Not cabled.	No action required.
Steady green	No traffic being transmitted, but link is up.	No action required.
Blinking green	There is traffic and packets are being transmitted or received.	No action required.

***1/10 GbE SFP+ port LEDs***

LED state	Status of hardware	Recommended action
Off (no light)	Not cabled.	No action required.
Steady green	Link is up in 10 GbE mode.	No action required.
Blinking green	There is 10 GbE traffic and packets are being transmitted or received.	No action required.
Steady amber	Link is up in 1 GbE mode.	No action required.
Blinking amber	There is 1 GbE traffic and packets are being transmitted or received.	No action required.

**40 GbE mode QSFP+ port LEDs (left-side LED)**

<i>LED state</i>	<i>Status of hardware</i>	<i>Recommended action</i>
<i>Off (no light)</i>	<i>Not cabled.</i>	<i>No action required.</i>
<i>Steady green</i>	<i>Link is up in 40 GbE mode.</i>	<i>No action required.</i>
<i>Blinking green</i>	<i>There is 40 GbE traffic and packets are being transmitted or received.</i>	<i>No action required.</i>

**4x10 GbE mode QSFP+ port LEDs**

<i>LED state</i>	<i>Status of hardware</i>	<i>Recommended action</i>
<i>Off (no light)</i>	<i>Not cabled.</i>	<i>No action required.</i>
<i>Steady amber</i>	<i>Link is up in 10 GbE mode.</i>	<i>No action required.</i>
<i>Blinking amber</i>	<i>There is 10 GbE traffic and packets are being transmitted or received.</i>	<i>No action required.</i>

**10/100/1000 Mbps UP and DN Ethernet port LEDs**

<i>LED state</i>	<i>Status of hardware</i>	<i>Recommended action</i>
<i>Off (no light)</i>	<i>Not cabled.</i>	<i>No action required.</i>
<i>Steady green</i>	<i>Link is up in 1 GbE mode.</i>	<i>No action required.</i>
<i>Blinking green</i>	<i>There is 1 GbE traffic and packets are being transmitted or received.</i>	<i>No action required.</i>
<i>Steady amber</i>	<i>Link is up in 10/100 Mbps mode.</i>	<i>No action required.</i>
<i>Blinking amber</i>	<i>There is 10/100 Mbps traffic and packets are being transmitted or received.</i>	<i>No action required.</i>



**Power supply unit LED**

<b>LED state</b>	<b>Status of hardware</b>	<b>Recommended action</b>
<i>Off (no light)</i>	<i>PSU is not powered on.</i>	<i>Verify that the PSU power cord is connected to a functioning power source</i>
<i>Steady green</i>	<i>PSU is on and functioning properly.</i>	<i>No action required.</i>
<i>Blinking green (with power cord connected)</i>	<i>External AC input parameters are within an acceptable range but there is no DC output or it is disabled.</i>	<i>Replace the power supply.</i>
<i>Steady amber</i>	<i>PSU has no DC output.</i>	<i>Replace the power supply.</i>

**Expansion module power LED**

<b>LED state</b>	<b>Status of hardware</b>	<b>Recommended action</b>
<i>Off (no light)</i>	<i>Module is not powered on.</i>	<i>No action required.</i>
<i>Steady green</i>	<i>Module is on and functioning properly.</i>	<i>No action required.</i>
<i>Steady amber</i>	<i>Module is on and booting up.</i>	<i>No action required.</i>

**Fan tray LED**

<b>LED state</b>	<b>Status of hardware</b>	<b>Recommended action</b>
<i>Off (no light)</i>	<i>Fan tray is not powered on.</i>	<i>No action required.</i>
<i>Steady green</i>	<i>Fan tray is on and functioning properly.</i>	<i>No action required.</i>
<i>Steady amber</i>	<i>Fan tray has nonfunctioning fans.</i>	<i>Replace fan tray.</i>

### 3.2.5 Cabling in the Net Unit

#### Cabling for SE700 / SE500 / SE300

The figures below show examples of the switch cabling in the Net Unit:

- Net Unit with one ICX6450-24/-48 extended by one ICX7750-48F
- Net Unit with two ICX6450-24/-48s extended by one ICX7750-48F
- Net Unit with two ICX6450-24/-48s extended by two ICX7750-48Fs

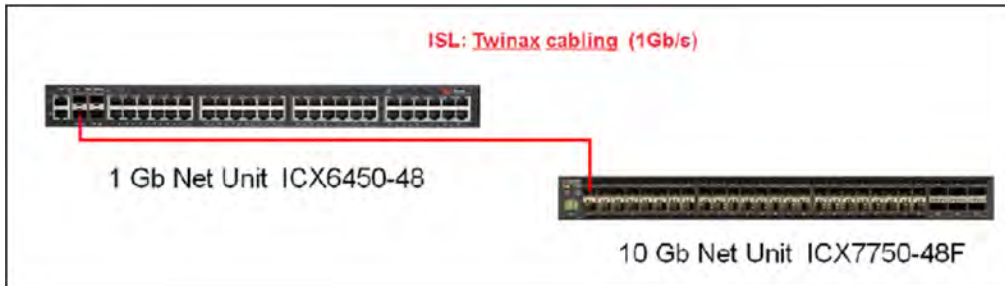

Figure 19: Net Unit with one ICX6450-24/-48 extended by one ICX7750-48F

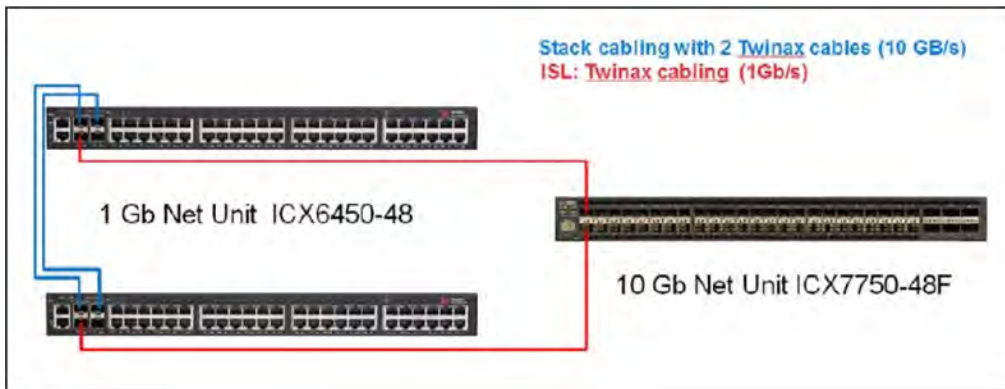

Figure 20: Net Unit with two ICX6450-24/-48s extended by one ICX7750-48F

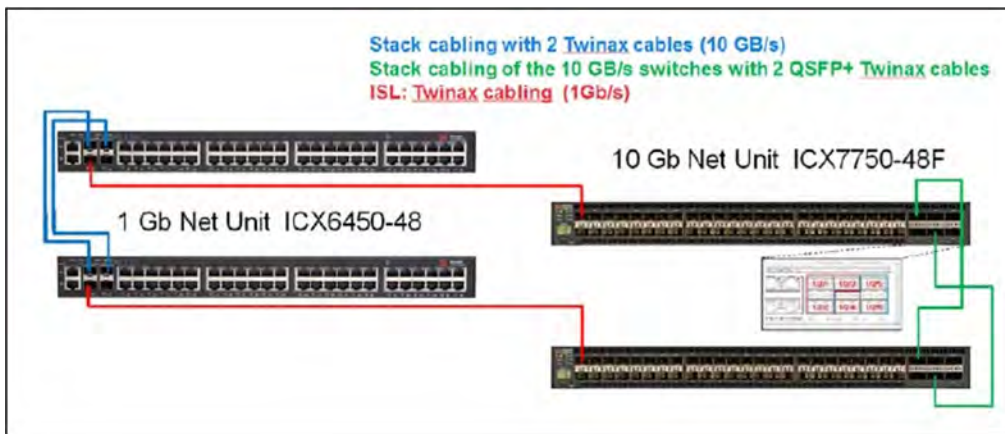

Figure 21: Net Unit with two ICX6450-24/-48s extended by two ICX7750-48Fs

## Cabling for SE710 / SE310

The figures below show examples of the switch cabling in the Net Unit:

- Net Unit with one ICX7450-48 extended by one ICX7750-48F
- Net Unit with two ICX7450-48s extended by one ICX7750-48F
- Net Unit with two ICX7450-48s extended by two ICX7750-48Fs

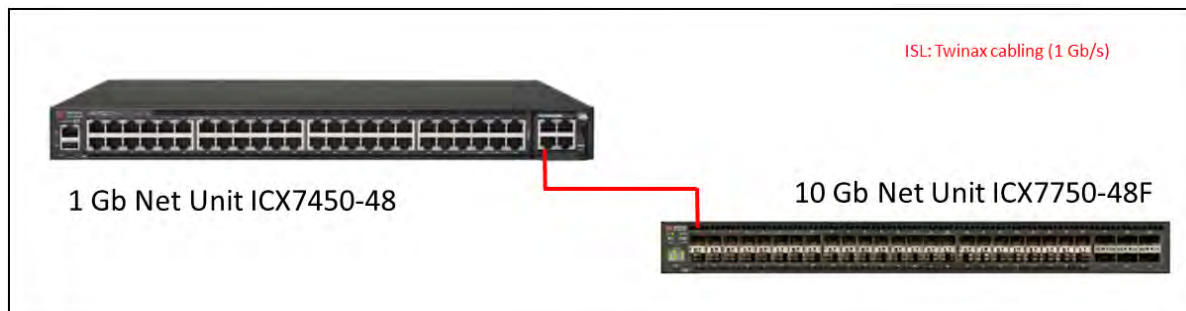

Figure 22: Net Unit with one ICX7450-48 extended by one ICX7750-48F

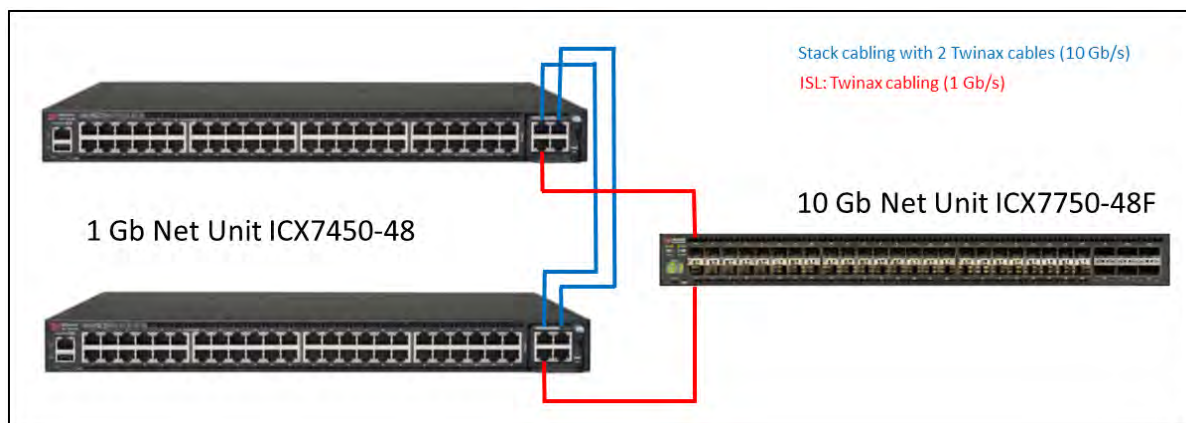

Figure 23: Net Unit with two ICX7450-48s extended by one ICX7750-48F

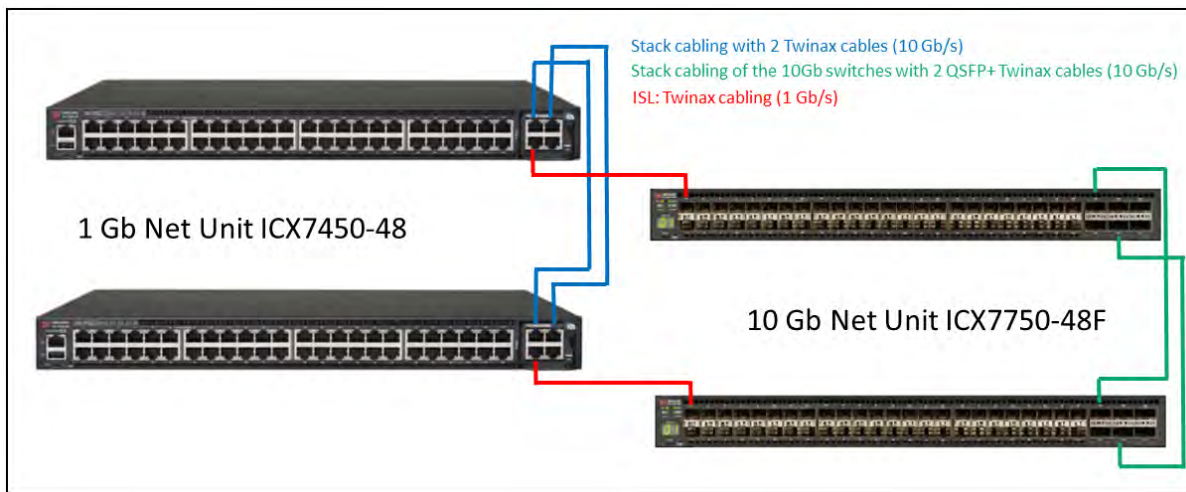

Figure 24: Net Unit with two ICX7450-48s extended by two ICX7750-48Fs

## 4 Periphery

The following peripherals can be operated on the SE server:

- ETERNUS DX disk storage system  
See <http://www.fujitsu.com/uk>:
  - > [Go to Support](#) -> *IT Products and Systems* -> *Storage*.  
In *Browse for Product* select product line *Storage* -> product group *ETERNUS* -> product family *ETERNUS DX*.
- ETERNUS CS tape storage virtualization system  
See <http://www.fujitsu.com/uk>:
  - > [Go to Support](#) -> *IT Products and Systems* -> *Storage*.  
In *Browse for Product* select product line *Storage* -> product group *ETERNUS* -> product family *ETERNUS CS*.
- Scalar tape library  
See <http://www.fujitsu.com/uk>:
  - > [Go to Products](#) -> *IT Products and Systems* -> *Servers* -> *BS2000 Mainframes* -> *Peripherals* -> *Tape Systems* and select *Scalar Series*.
- ETERNUS JX40 disk storage system  
See [section "ETERNUS JX40 \(S2\) disk storage system"](#).
- ETERNUS LT40 S2 tape library  
See [section "ETERNUS LT40 S2 tape library"](#).
- ETERNUS DX100 S4 disk storage system  
See [section "ETERNUS DX100 S4 disk storage system"](#).
- ETERNUS LT140 tape library  
See [section "ETERNUS LT140 tape library"](#).

This section covers the following topics:

- [ETERNUS JX40 \(S2\) disk storage system](#)
  - [Indicator elements \(front\)](#)
  - [Operating and indicator elements \(rear\)](#)
  - [Problem Solutions and Tips](#)

- ETERNUS LT40 S2 tape library
  - Front panel
  - Rear panel
  - Operating the tape library
  - Magazines
  - LTO tape cartridges
  - Working with the tape library
  - Error handling
- ETERNUS DX100 S4 disk storage system
- ETERNUS LT140 tape library

## 4.1 ETERNUS JX40 (S2) disk storage system

This device is supported on SU300 only.

ETERNUS JX40 and ETERNUS JX40 S2 disk storage systems with an SAS port can be integrated into the SE server when required:

- Up to two systems can be connected to an SU300.
- On an AU, up to two systems can be connected to one controller.

An ETERNUS JX40 (S2) disk storage subsystem occupies two height units in the rack. Per disk storage system, up to 24 drives with the following gross capacity can be employed:

- Up to 1200 GB per drive with ETERNUS JX40
- Up to 1800 GB per drive with ETERNUS JX40 S2

Therefore, the ETERNUS JX40 disk storage system enables up to 28.8 TB and the ETERNUS JX40 S2 up to 43.2 TB of disk storage space to be provided. When mirroring is used, the net capacity of the disks is lower.

For details, please refer to the description provided by FUJITSU under <http://www.fujitsu.com/uk>.

- > Go to *Support* -> *IT Products and Systems* -> *Storage*. In *Browse for Product* select product line *Storage* -> product group *ETERNUS* -> product family *ETERNUS JX* -> product *ETERNUS JX40 S2*.

The disk storage system is switched on/off automatically when the SU300 or AU is switched on/off.



Figure 25: ETERNUS JX40 (S2) disk storage system

The numbering of the various hard disk drives is shown by the numbers (0..23) below them.

This section covers the following topics:

- [Indicator elements \(front\)](#)
- [Operating and indicator elements \(rear\)](#)
- [Problem Solutions and Tips](#)

### 4.1.1 Indicator elements (front)

The status LEDs of the disk storage system and the status indicators of the disk drives are visible at the front of the ETERNUS JX40 (S2) disk storage system.

**i** Further controls which are reserved for Customer Support are provided behind the (removable) cover.

#### Operating Status LEDs

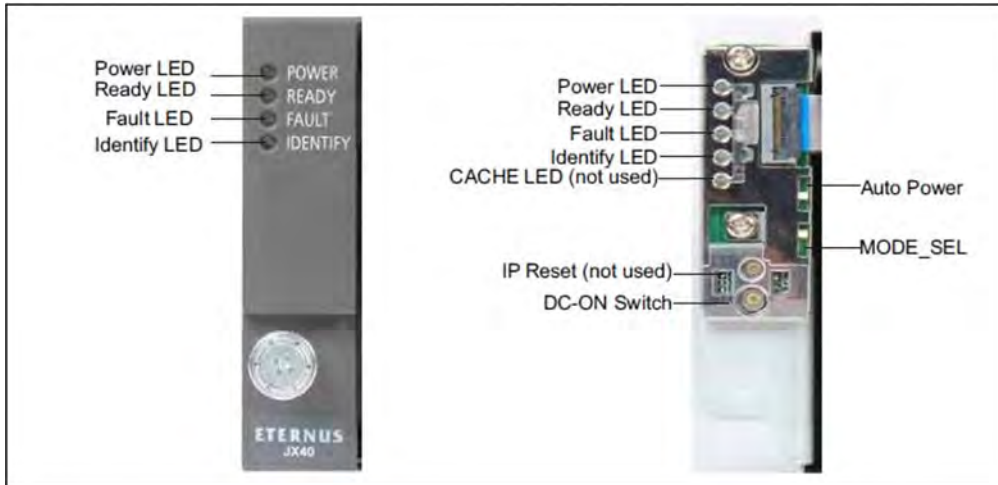

Figure 26: Operating Status LEDs

LED	Color	Status	Meaning
Power Power supply	Green	On	Power on
		Off	Power off
Ready Operating status	Green	On	Normal operation
		Off	Not ready
Fault Error status	Yellow	Off	No fault
		On	Error detected, notify Customer Support
Identify Identification	Blue	Blinking	Identification

#### **!** CAUTION!

The subsystem does not switch off automatically in the case of overheating in order to allow the the connected server to be shut down properly. Overheating is reported in the BS2000 console window and also results in a Remote Service call.



## Status LEDs of the hard disk drives



Figure 27: Status LEDs of the hard disk drives

LED	Color	Status	Meaning
Ready LED	Green	On	Normal operation
		Off	Not ready
Fault LED	Yellow	Off	Normal operation
		On/blinking	Error detected, notify Customer Support

**i** Each of the 24 possible hard disk drives has a “Ready” LED and a “Fault/Identification” LED.

### 4.1.2 Operating and indicator elements (rear)

You can see the status LEDs of the SAS I/O module and the status LEDs of the power supply units on the rear side of the ETERNUS JX40 (S2) subsystem.

#### Status LEDs of the SAS expander unit

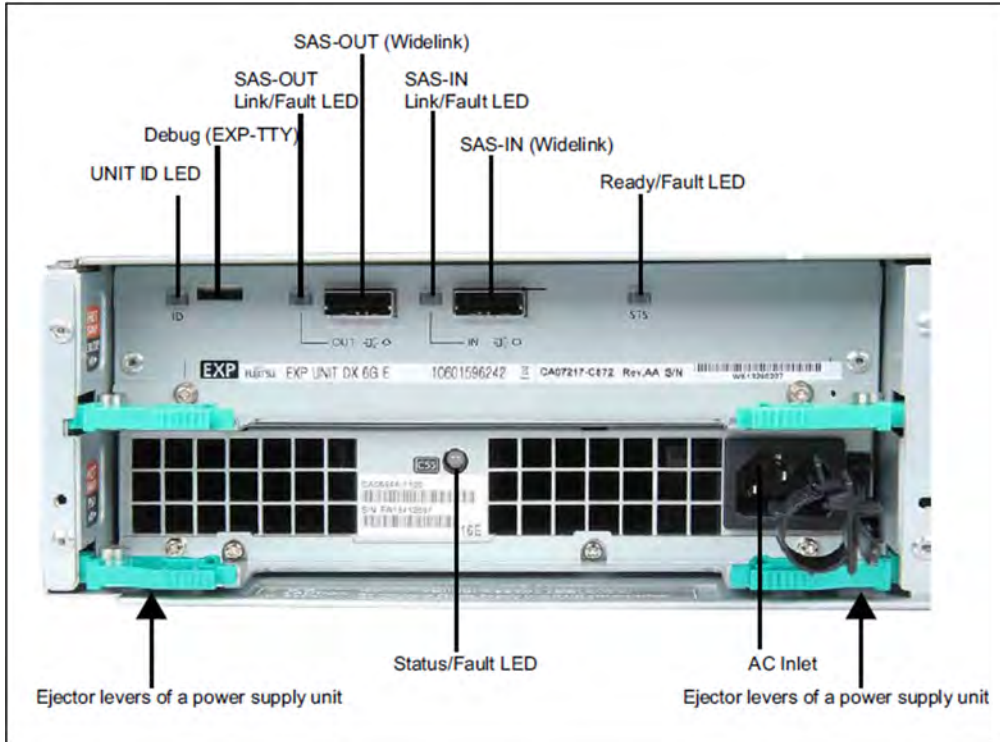

Figure 28: Status LEDs on the rear of the device

The status LEDs of the SAS I/O module are located in the upper part of the device.

LED	Color	Status	Meaning
UNIT ID LED Identification status	Blue	Blinking	Identification
SAS OUT LED / SAS IN LED SAS ingoing/outgoing status	Green	On	Link up
	Yellow	On	Error detected, notify Customer Support
Status/Fault LED Error status	Green	On	Normal operation
	Yellow	On	Error detected, notify Customer Support

#### Status LEDs of the power supply units

The status LEDs of the power supply units are located in the lower part of the devices (see [figure 21](#)).

LED	Color	Status	Meaning
	Green	On	Normal operation

Status/Fault LED Error status		Blinking	Stand by
	Yellow	On	Error detected, notify Customer Support

### 4.1.3 Problem Solutions and Tips

When operation is disrupted, please notify Customer Support. On no account should you attempt to make repairs yourself! The following sections describe irregularities which can be observed on the disk storage subsystem in case of faults.

#### **Power supply status LED (front)**

If the power supply status LED is green the device is switched on and the power supply and at least one power supply unit are OK. When the power supply status LED remains dark, the power supply units may be defective:

- > Check the power supply units' LEDs.

#### **Identification status LED**

When the identification status LED is on, this means this LED was switched on to identify the system. There is no fault.

#### **Fault status LED**

When the fault status LED lights up during ongoing operation, this means that a fault has been detected.

- > Please notify Customer Support.

#### **Status LED of the hard disk drive does not light up**

- > Please notify Customer Support.

#### **The drives were indicated as dead when the system started up**

- > Please notify Customer Support.

## 4.2 ETERNUS LT40 S2 tape library

This device is supported on SU700, SU500 and SU300 only.

The ETERNUS LT40 S2 tape library is a compact, high-performance and low-cost device for mounting in a rack for the purpose of simple and automatic data backup. It is available for the SE server in two variants:

- ETERNUS LT40 S2 with FC or SAS connection and one or two half-height LTO-5 drives
- ETERNUS LT40 S2 with FC connection and one or two half-height LTO-6 drives

ETERNUS LT40 S2 tape libraries can be integrated into the SE server when required:

- Up to two systems can be connected to an SU300.
- On an AU up to two systems can be connected to one controller.

In this chapter the ETERNUS LT40 S2 tape library is referred to as “the tape library” for short.

In both variants ETERNUS LT40 may contain one or two disk drives and one or two removable magazines. The left-hand magazine has an import/export port (I/E port - this is referred to as the mailslot below). Each magazine can contain up to twelve magnetic tape cartridges. If the mailslot is activated, the number of usable slots for storing MTCs is reduced by three.

During BS2000 operation the mailslot is always activated, i.e. depending on the license 9 or 21 cartridge slots are available for BS2000 operation.

An integrated robot loads and unloads the drives. A barcode reader is integrated into the robot units, which enables the tapes to be addressed by means of the names on the labels of the cartridges.

### Maximum storage capacity and data transfer rate

Characteristic	Data
<b>ETERNUS LT40 S2 tape library (FC or SAS variant) with LTO-5 drive</b>	
Maximum storage capacity (12/24 tape cartridges)	Uncompressed: 1500 GB per MTC (18/36 TB in total) Compressed: 3000 GB per MTC (36/72 TB in total, 2:1 compression)
Maximum Write/Read rate	Write: 140 MB/s(504 GB/hr) Read: 280 MB /s (1008 GB/hr)
Drive type	LTO-5 HH
Number of slots	12/24 (including mailslots)
Interface	FC or SAS
<b>ETERNUS LT40 S2 tape library with LTO-6 drive</b>	
Maximum storage capacity (12/24 tape cartridges)	Depends on tape, e.g. Quantum: Uncompressed: 2.5 TB per MTC Compressed: 6.25 TB per MTC

Data rate	QUANTUM Ultrium 6 tapes: Uncompressed: 160 MB/s Compressed: 400 MB/s
Drive type	LTO-6 HH
Number of slots	12/24 (including mailslots)
Interface	FC

Table 1: Maximum storage capacity

This section covers the following topics:

- [Front panel](#)
- [Rear panel](#)
- [Operating the tape library](#)
  - [Operating panel on the device](#)
  - [Remote Management Unit \(RMU\)](#)
- [Magazines](#)
  - [Removing and replacing a magazine using the OCP](#)
  - [Removing and replacing a magazine using the RMU](#)
  - [Inserting tape cartridges into a magazine](#)
  - [Mailslots](#)
- [LTO tape cartridges](#)
- [Working with the tape library](#)
  - [Modes of the tape library](#)
  - [Device settings](#)
- [Error handling](#)
  - [Removing stuck tapes from slots](#)
  - [Tape library error codes](#)

## 4.2.1 Front panel

The power button, operator control panel (OCP), magazines and LEDs are located on the front of the tape library.

The operator panel consists of an LCD screen, 4 push button switches and a power on/off button.

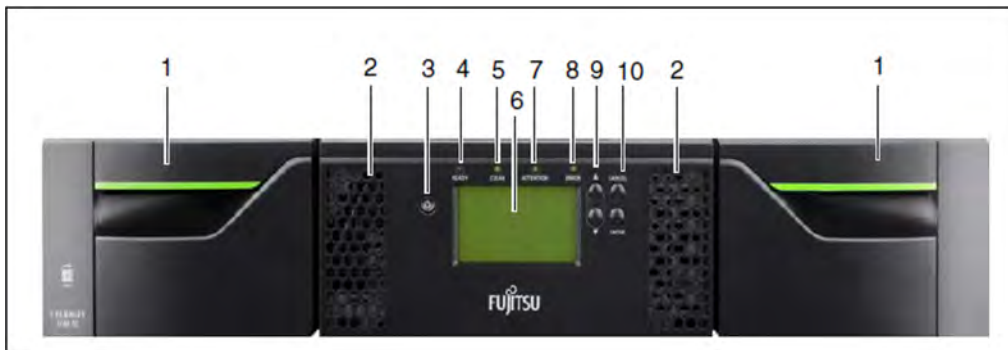

Figure 29: ETERNUS LT40 S2 front panel

No.	Meaning
1	Left-hand or right-hand magazine. Left-hand magazine with mailslots.
2	Air vents
3	Power button. Pressing the button will power up or power down the library, see " <a href="#">Operating panel on the device</a> ".
4	READY LED (green). Illuminated when power is on. Blinking when there is tape or robotics activity.
5	CLEAN LED (yellow). Illuminated when the tape drive has determined that a cleaning cartridge should be used.
6	the OCP's LCD screen, consisting of 128 x 64 characters. Displays actions and status information, menu items or error messages.
7	ATTENTION LED (yellow). Illuminated if the library has detected a condition that requires attention by Customer Support. Please notify customer support.
8	ERROR LED (yellow). Illuminated if an unrecoverable tape drive or library error occurs. A corresponding error message displays on the LCD screen. Please notify customer support.
9	Control key buttons (UP) and (DOWN). These buttons are used to navigate through the OCP menu items.
10	Control key buttons CANCEL and ENTER. The cancel button is used to cancel a user action and return to the last OCP menu item. The enter button is used to go to a sub menu or execute an action.

## 4.2.2 Rear panel

The rear panel of the tape library provides access to the SAS or Fibre Channel (FC) connector, tape drives, the power connector, LAN, and to the serial and USB port.

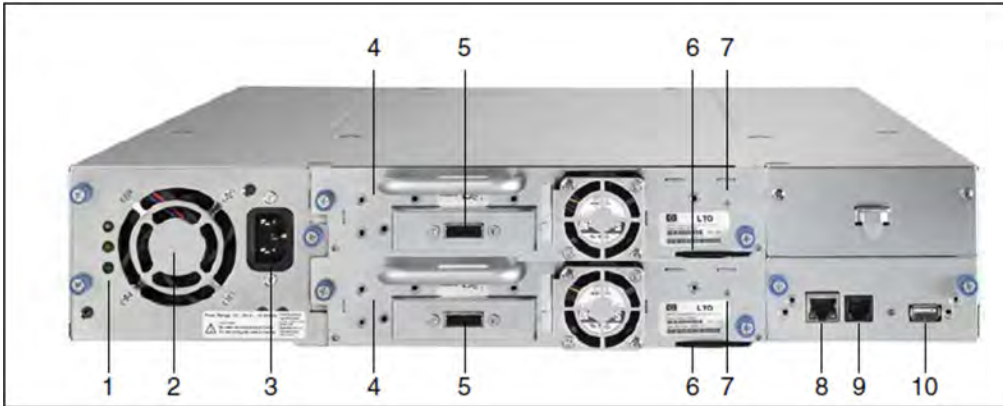

Figure 30: ETERNUS LT40 S2 rear panel (SAS variant with two drives)

No.	Meaning
1	Power Supply LED's from top: <ul style="list-style-type: none"> <li>• blue LED on &gt;&gt; AC connected</li> <li>• yellow LED on &gt;&gt; degraded fan</li> <li>• green LED on &gt;&gt; Power good</li> </ul>
2	Air vent
3	Power connector
4	Tape drives
5	SAS or Fibre Channel (FC) connector for each drive
6	Product label foil for each drive
7	Tape Drive LED for each drive
8	LAN port (connected to the Net Unit)
9	Serial port (Customer Support)
10	USB port (Customer Support)



### 4.2.3 Operating the tape library

This section contains information on operating the tape library.

This section covers the following topics:

- [Operating panel on the device](#)
- [Remote Management Unit \(RMU\)](#)

### 4.2.3.1 Operating panel on the device

The tape library is by default operated via the Operator Control Panel (OCP). The LCD display of the OCP shows the tape library's operating status and actions (e.g. "Loading", "Rewinding" or "Moving tape").

**i** The tape library is protected by preinstalled IDs and passwords. Customer Support knows these IDs and passwords. You are recommended to change these passwords at startup. If you change the passwords, please ensure that the changed passwords are available when support is required.

## Basic rules

OCP operation must obey some basic rules:

- Any operational conflict between commands received over the BS2000 system and those entered via the OCP will be avoided with a reservation mechanism on a 'firstcome, first-served' basis. The OCP commands are stored only until a logout or automatic timeout takes place, or until Manual Mode is returned to automatically (see "[Modes of the tape library](#)").
- Library firmware will not allow a user to select an impossible action, e.g.:
  - Moving a cartridge from any source to a full slot
  - Moving a cartridge from an empty slot
  - Loading a cartridge from any source to a full drive
  - Unloading a cartridge from an empty drive
- Any error detected by the library or drive controller and not recoverable through predetermined firmware algorithms will be considered as fatal. An error code will be displayed on the LCD screen and the error LED will become illuminated. The error code will remain displayed until a push button is pressed on the operator control panel. This then causes the LCD screen to return to the Home Screen of the menu system.

## Power-up display

When the tape library powers up after pressing the power button, or resets, it goes through several internally controlled processes that allow it to get initialized and running. These processes are called Power-On-Self-Test (POST). While the POST is happening, the LCD screen shall have appropriate information displayed to keep the user informed. When the tape library finishes coming alive, it will display the current device status for a defined time or until a key is pressed.

After this initial status screen the home screen will be shown until a key is pressed. This home screen shows the overall health of the tape library, indicating the status of the robotic and the connected drives.

## Note about the LEDs

All LEDs are updated during Power Up and Reset sequences. Upon power up or software Reset, the loader will illuminate all LEDs as soon as POST allows. This will help the User to verify if all LEDs are functional. When initialization starts, all LEDs will be extinguished and the Ready/Activity LED will flash at a reasonable rate of approximately 1-second per cycle, 50% duty cycle. When the mechanical initialization is complete, the Ready /Activity LED will stop flashing and be constantly illuminated.

If a loader failure occurs, the Ready/Activity LED will be turned off and the Error LED will be illuminated. The LCD screen will also display an appropriate error code to help identify the failure.

## **Input modes**

There are several modes to enter values in the different menu items. These values are: selectable predefined values, toggle values (e.g. On/Off) and numerical values such as network addresses.

### ***Selectable predefined values***

After the menu item has been reached, the various predefined values can be selected using the UP and DOWN keys (arrow up, arrow down). When the required value has been selected, it is entered by pressing the ENTER key.

### ***Toggle values***

Toggle values are used to switch between two different states like On and Off. After navigating to the menu item the display shows the actual state. Pressing the ENTER button will toggle to the possible new state. Pressing the ENTER button a second time will take over this new state.

### ***Numerical values***

Numerical values are needed for network addresses, PIN entries, and other configuration entries. After navigating to the menu item to be changed, the actual value will be displayed and the cursor stays on the first digit. The value may be incremented / decremented with the UP and DOWN button. After pressing the ENTER button the cursor is set to the next editable digit. It can be changed in the same way. After pressing the ENTER button at the last digit the complete entry will be stored. Pressing the CANCEL button will cancel the whole edit process and the old value is valid again.

## OCP menu flowcharts

You will find the menu tree overview in other languages in the language options of the "ETERNUS LT40 S2 Quick Start Guide" available for downloading from the following website: <http://www.fujitsu.com/uk> :

- > [Go to Support](#) -> [IT Products and Systems](#) -> [Storage](#). In [Browse for Product](#) select product line [Storage](#) -> product group [ETERNUS](#) -> product family [ETERNUS LT](#) -> product [ETERNUSLT40 S2](#) and the [Documents](#) heading.

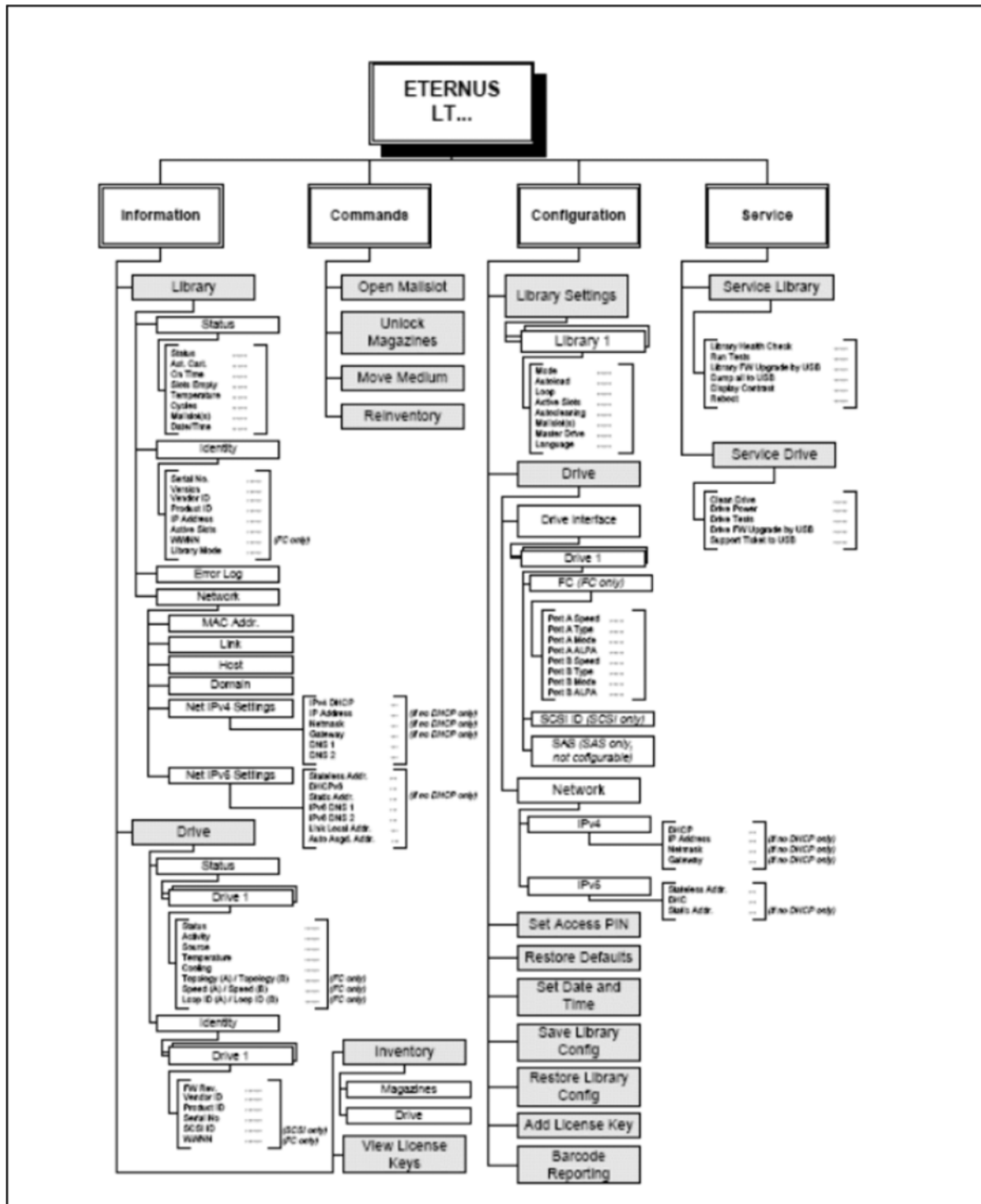

Figure 31: OCP menu flowcharts



## Actions via the OCP

*Some actions can be executed on the tape library using the OCP (and also via the RMU):*

- *Opening a mailslot (menu Commands > Open Mailslot)*
- *Unlocking a magazine (menu Commands > Unlock Magazines)*
- *Moving cartridges between the slots (menu Commands > Move Media)*
- *Initiating an inventory (menu Commands > Reinventory)*

*When the Move Media action is started, the tape library closes Random Mode and operates in Sequential Mode. Once the operation has been completed, it switches back to Random Mode. This behavior is logged on the BS2000 system, see [section "Modes of the tape library"](#).*

**i** *Detach the device while BS2000 is operating (/DETACH-DEVICE) before you execute actions via the OCP.*

## Shutdown

*Pressing the Power On/Off button will initiate a controlled Power Down of the unit.*

*The following operations will take place before the library shuts down completely:*

- *The LCD display indicates with an appropriate message that the shutdown is in progress*
- *The library finishes all ongoing library and drive activities*
- *The robotics is moved to its home position*
- *The library switches off the power supply's secondary side*

**i** *To abort the shutdown process the user has to press the CANCEL button within the first 3 seconds.*

### 4.2.3.2 Remote Management Unit (RMU)

Alternatively to the OCP, you can operate the tape library conveniently via the administration LAN using a web-based user interface, the Remote Management Console (RMU). The RMU largely offers the same functionality as the OCP.

A prerequisite for access to the RMU is that a network connection exists and a LAN address is configured (see the "Operation and Administration" manual [5]).

You call the RMU in the browser by entering the following URL in the address bar:

- `http://<IP address>`
- or `http://<name>` (if the name is configured in the DNS)

You can store a corresponding link in the SE Manager on the MU (see the "Operation and Administration" manual [5]) and use it as an alternative for calling the RMU.

The first page you are shown is the device's login page, which enables you to log in under user accounts (they are named *Guest* and *Admin* or *User* and *Administrator*, depending on the library's firmware version). The *Service* account is reserved for Customer Support. Each of these accounts is protected by a password. You should change the passwords which are preset when supplied (see "Changing the password of the access account").

After you have logged in successfully, you are shown the first page under *Identity > Library*, which displays the overview containing the *Library Information*.

The screenshot shows the ETERNUS LT40 Remote Management web interface. The browser title is "ETERNUS LT40 Remote Management - Mozilla Firefox". The page header includes "ETERNUS" and "User ID Administrator Logoff FUJITSU". Below the header, there is a status bar showing "Normal" and various system details: "riva6", "Product ID: ETERNUS LT40", "Serial Number: LTDE65417300", and "Date: 05/15/2012 13:05:24". The main content area is divided into two sections: "Library Information" and "System Status".

Library Information		System Status	
Serial Number	LTDE65417300	Status	Ready
Product ID	ETERNUS LT40	Drive 1 Status	Ready
Currently Installed Library Firmware	4.63 / 3.10e	Drive 2 Status	Ready
Bootcode Firmware Revision	0.80	Slots (Free/Total)	2/9
Barcode Reader	SE625	Mailslot	Closed
Library Mode	Manual, Random		
WWide Node Name	2000000E111C0F60		

The RMU supports several languages, English being the default. The functionality of the RMU is described in detail in the manual

The functionality of the RMU is described in detail in the "ETERNUS LT40 S2 / LT60 S2" manual. You can download the manual at the address <https://support.ts.fujitsu.com>:

- > Go to *Support* -> *IT Products and Systems* -> *Storage*. In *Browse for Product* select product line *Storage* -> product group *ETERNUS* -> product family *ETERNUS LT* -> product *ETERNUS LT40 S2*.

## Changing the password of the access account

You can change the password of the user account you used to log in on the RMU (e.g. by replacing the default password with a new password):

- > Select Configuration > User.
- > Enter the new password and repeat this entry.
- > Click Refresh to confirm.

The screenshot shows the ETERNUS LT40 Remote Management web interface in Mozilla Firefox. The browser title is "ETERNUS LT40 Remote Management - Mozilla Firefox". The address bar shows "ETERNUS LT40 Remote Management". The page header includes "ETERNUS" and "User ID Administrator Logoff FUJITSU". The main content area is divided into several sections:

- Normal** (status indicator)
- Product ID: ETERNUS LT40, Serial Number: LTDE65417300, Date: 05/15/2012 15:14:06
- Navigation tabs: Identify, Status, Configuration, Operations, Service
- User Configuration** section:
  - Access Level: 2 (dropdown)
  - Access Level Name: Administrator
  - New Password (Enter Up To Ten Characters): [masked]
  - Repeat Password: [masked]
- OCP Pin Configuration** section:
  - OCP Access Pin Enabled: [checkbox]
  - OCP Access Pin Code: [masked]
  - Repeat OCP Access Pin Code: [masked]
- Support Configuration** section:
  - Support Name: [text input]
  - Support Phone: [text input]
  - Support Email: [text input]
- Buttons: Refresh, Submit

On the right side, there is a **System Status** section with a "View Legend" link and the following status indicators:

- Status: Ready (green checkmark)
- Drive 1 Status: Ready (green checkmark)
- Drive 2 Status: Ready (green checkmark)
- Slots (Free/Total): 2/9
- Mailslot: Closed



## 4.2.4 Magazines

Cartridges are stored in the slots of the magazines. Up to 12 cartridges can be stored in each magazine. Magazines may be removed and inserted individually.

The tape library has two removable magazines with an installation height of two height units. Access to the magazines can be protected by a password. For safety reasons, the robotic motion is stopped when a magazine is removed.

The magazines can be released (“unlocked”) using the Operator Control Panel (OCP) or the Remote Management Unit (RMU). If the process has failed or the library no longer has power, a manual emergency release is available. See [section "Removing stuck tapes from slots"](#).

This section covers the following topics:

- [Removing and replacing a magazine using the OCP](#)
- [Removing and replacing a magazine using the RMU](#)
- [Inserting tape cartridges into a magazine](#)
- [Mailslots](#)

#### 4.2.4.1 Removing and replacing a magazine using the OCP

##### **!** CAUTION!

The magazine must only be removed with the manual emergency release in an emergency. Failure to follow normal procedure can cause data loss and equipment damage.

The magazines should be released (“unlocked”) using the Operator Control Panel (OCP) or the Remote Management Unit (RMU). Only if this process fails, or if the magazine needs to be removed when the power to the tape library is off, you can release the magazines with the manual emergency release.

You can access the left and right magazines using the Operator Control Panel (OCP). You require the system administrator password to do this.

- > On the OCP select the “Unlock Left Magazine” or “Unlock Right Magazine” function in the menu *Commands > Unlock Magazines*.
- > Enter the administrative password if requested.
- > The display will read “Left Magazine Unlocked”, or “Right Magazine Unlocked”.
- > Pull the released magazine out of the library.

The screen will now display “Insert Left Magazine”, or “Insert Right Magazine”. The library cannot perform any other operation until the magazine is replaced. After exchanging tapes in a magazine, slide the magazine completely into the library. The magazine will lock into place once it is correctly installed and the library will inventory the magazine.

#### 4.2.4.2 Removing and replacing a magazine using the RMU

> To log on, enter the correct password and press the ENTER key.

> Select *Operations > Magazines*.

In the next menu you can select the left or right magazine.

> Click *Release*.

You can now remove the magazine from the library.

#### 4.2.4.3 Inserting tape cartridges into a magazine

Unlock the magazines and remove them from the tape library

- > via OCP, see [section "Removing and replacing a magazine using the OCP"](#).
- > via RMU, see [section "Removing and replacing a magazine using the RMU"](#).
- > Insert cartridges in the magazines.
- > Put the magazines back to the library.

#### 4.2.4.4 Mailslots

Mailslots are used to import/export individual cartridges without interrupting library operation. The time-consuming inventory of all the cartridges is consequently not required when a magazine is inserted. Always use the mailslot to import/export cartridges.

Mailslots are always activated in BS2000 operation. Consequently 3 fewer slots are available for storing cartridges in BS2000 operation. BS2000 can use 9 slots in the left-hand magazine and 12 slots in the right-hand one.

As soon as the mailslots are enabled, the three associated slots are no longer visible from BS2000, i.e. the `/SHOW-TAPE-STATUS <mn>, INFO=CARTRIDGE` command does not show these slots. These three slots are consequently not available to accommodate cartridges.

The tables below show the numbering of the slots (including the mailslots) when the cartridges or their labels are viewed:

Mailslot 3: cleaning cartridge (used for auto cleaning)	Slot 7	Slot 8	Slot 9
Mailslot 2: I/E port (BS2000) (drive 2 if present, otherwise unused)	Slot 4	Slot 5	Slot 6
Mailslot 1: I/E port (BS2000) (drive 1)	Slot 1	Slot 2	Slot 3

Table 2: ETERNUS LT40 S2: Slot numbers of the left magazine with mailslots

Slot 21	Slot 20	Slot 19	Slot 18
Slot 17	Slot 16	Slot 15	Slot 14
Slot 13	Slot 12	Slot 11	Slot 10

Table 3: ETERNUS LT40 S2: Slot numbers of the right magazine

The command to open a mailslot may be denied if the robotics is busy with some operation. In that case "Busy" is displayed. The command has to be repeated once the robotics operation is finished..

You move cartridges from a slot or a drive to a mailslot and vice versa via OCP using the menu *Commands > Move Media*.

## 4.2.5 LTO tape cartridges

Only use the data and cleaning cartridges recommended here. By doing so you will extend the service life both of the cartridges and of the tape library. The use of other cartridges may result in the LTO drive malfunctioning.

### Data cartridges

LTO-5 drives support LTO-3 (read only), LTO-4 and LTO-5 magnetic tape cartridges.

LTO-6 drives support LTO-4 (read only), LTO-5 and LTO-6 magnetic tape cartridges.

LTO-7 drives support LTO-5 (read only), LTO-6 and LTO-7 magnetic tape cartridges.

### Cleaning cartridges

Only use the cleaning cartridges from Fujitsu Technology Solutions. The use of other cartridges may result in the LTO drive malfunctioning.

### Using and maintaining tape cartridges

LTO-5 devices (FC variant) are addressed in the BS2000 system by means of:

device type: LTO-U5, device type code: CF, volume type: TAPE-U5, TAPE-U5E (encrypted).

LTO-6 devices are addressed in the BS2000 system by means of:

device type: LTO-U6, device type code: D1, volume type: TAPE-U6, TAPE-U6E (encrypted).

LTO-7 devices are addressed in the BS2000 system by means of:

device type: LTO-U7, device type code: D2, volume type: TAPE-U7, TAPE-U7E (encrypted).

### Labeling tape cartridges

Attaching a barcode label to each tape cartridge enables the library and the data backup software to identify the cartridge quickly, thereby speeding up inventory time. Make it a practice to use barcode labels on your tape cartridges. The data backup software may need to keep track of the following information via the associated barcode:

- Date of format or initialization
- Tape's media pool
- Data residing on the tape
- Age of the backup
- Errors encountered while using the tape (to determine if the tape is faulty).

**!** **CAUTION!** The misuse and misunderstanding of barcode technology can result in backup and restore failures. To ensure that your barcodes meet manufacturers' quality standards, always purchase them from an approved supplier and never print barcode labels yourself.

Ultrium tape cartridges have a recessed area located on the front of the cartridge next to the write-protect switch. Use this area for attaching the adhesive-backed barcode label. Only apply labels as designated in the following figure:

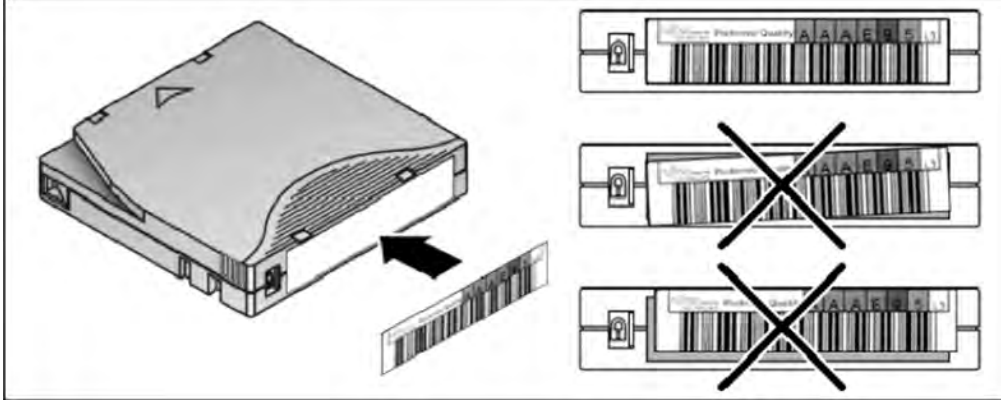

Figure 32: Ultrium tape cartridge and proper barcode label placement

**! CAUTION!**

The barcode label should only be applied as shown in the figure above with the alphanumeric portion facing the hub side of the tape cartridge. Never apply multiple labels onto a cartridge, as extra labels can cause the cartridge to jam in a tape.

### Write-protecting tape cartridges

All rewritable tape cartridges have a write-protect switch to prevent accidental erasure or overwriting of data.

### Barcode reader

The barcode reader provides inventory feedback to the host application and/or LCD screen by reading the cartridge barcode labels. The library stores the customized inventory data in memory.

## 4.2.6 Working with the tape library

This section contains hardware-related information on working with the tape library when it is used as a BS2000 device.

**i** Cartridges without a label which are contained in the cartridge magazine are not displayed by BS2000. You are therefore urgently recommended only to use cartridges with a label.

This section covers the following topics:

- [Modes of the tape library](#)
- [Device settings](#)



#### 4.2.6.1 Modes of the tape library

The tape library is released for BS2000 operation in two modes (library modes): Random Mode and Sequential Mode. "Autoload" and "Loop" modes can also be activated in Sequential Mode. You can switch explicitly between Random and Sequential Mode, see "[Device settings](#)".

### Random Mode

Random Mode is the default operation mode and also the normal operation mode when being used by BS2000. In Random Mode the application software controls when which cartridge is mounted or ejected.

When a manual action is initiated by the OCP (or RMU), e.g. the export of a cartridge (i.e. a cartridge is moved using the OCP menu *Commands > Move Media*), the tape library uses Sequential Mode for the duration of this action and then switches back to Random Mode. During this interruption of the current operation mode, the device displays "*Busy Rand Action Move*" in the operator control panel. Messages to this effect are displayed on the BS2000 console. Messages also report when Random Mode is disabled or enabled.

### Sequential Mode

From the BS2000 viewpoint Sequential Mode corresponds to automatic or manual mode with continuation tapes - all tapes are automatically used one after the other.

Sequential Mode has the additional options Autoload and Loop.

- When Autoload is enabled and the drive is empty, the tape is loaded in the slot with the lowest number after the tape library has been rebooted or powered-on.
- When Loop is enabled, following the last tape operation continues again with the first tape, otherwise the tape library will stop and wait for the user to intervene.

### 4.2.6.2 Device settings

The device settings are defined by Customer Support. The sections below provide information on how you can change these settings.

If you wish to make any changes to the configuration, you should consult Customer Support, who will ensure that the functionality of the device is retained in BS2000 operation.

#### **Configuring the LAN connection**

You configure the LAN connection of the tape library using the OCP:

- > Select the OCP menu *Configuration > Network*.
- > Configure the following parameters in the order specified:
  1. DHCP - No DHCP (a static IP address is recommended)
  2. (Static) IP address
  3. Network mask
  4. Gateway address

After you have completed network configuration, you should reboot the tape library (by switching the device off and on). The RMU can then be accessed via the configured IP address.

#### **Settings for operation with BS2000**

You must specify the following settings for operation with BS2000:

- > Select *Configuration > Library* in the OCP menu or *Configuration > System* via the RMU.

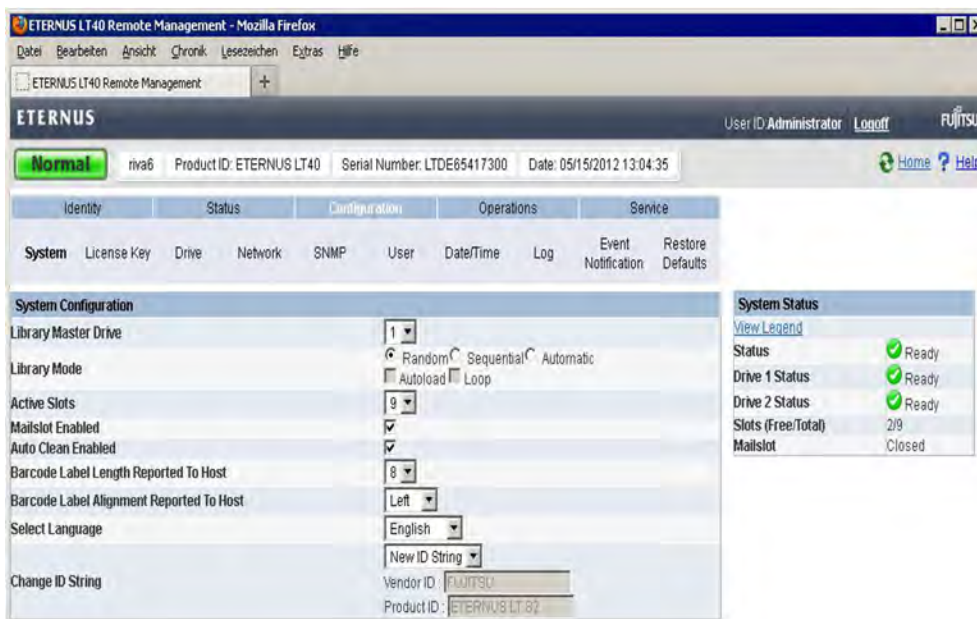

- > Enable the *Random* option in *Library Mode*.
- > Enable the mailslot.
- > Enable auto cleaning.
- > Click *Refresh* to activate the changes.

**i** When two drives are operating in Sequential Mode, you are recommended not to enable the *Autoload* and *Loop* options, see the note on "[Device settings](#)".

To guarantee BS2000 operation, you may **not** change the following configuration settings:

*Configuration > System* (SAS variant):

- Mailslot(s) -> active
- Auto Clean -> active
- Barcode Label Length ... -> 8
- Barcode Label Alignment ... -> Left

*Configuration > Drive* (FC variant):

- Recommendation -> Fixed topology / Speed setting

## Logical partitioning

From the BS2000 viewpoint, a tape library with two drives looks like two separate devices; it is “logically partitioned” in X2000. This partitioning is performed automatically and cannot be configured. The slots are assigned to the devices as evenly as possible, the last (second) drive possibly being assigned one slot more.

### Example

Partitioning an ETERNUS LT40 S2 tape library with magazines and two drives:

Mailslot 3	<b>Slot 7</b>	<b>Slot 8</b>	<b>Slot 9</b>
<i>Mailslot 2</i>	<b>Slot 4</b>	<b>Slot 5</b>	<b>Slot 6</b>
<b>Mailslot 1</b>	<b>Slot 1</b>	<b>Slot 2</b>	<b>Slot 3</b>

Table 4: Left-hand magazine

<i>Slot 21</i>	<i>Slot 20</i>	<i>Slot 19</i>	<i>Slot 18</i>
<i>Slot 17</i>	<i>Slot 16</i>	<i>Slot 15</i>	<i>Slot 14</i>
<i>Slot 13</i>	<i>Slot 12</i>	<i>Slot 11</i>	<b>Slot 10</b>

Table 5: Right-hand magazine

The slots shown in bold letters are assigned to the first drive. The slots shown in italic letters are assigned to the second drive. The cleaning slot (mailslot 3) is not permanently assigned.

In BS2000 mode it must be borne in mind that the two tape devices use the same robot to load and unload the cartridges; wait times can occur here. The two logical devices are also always in the same operating status. It is not possible to operate one device in Random Mode and the other in Sequential Mode.

Generally most settings are valid for both logical devices.

In the OCP menu *Configuration > Library Settings* you set the drive (*Master Drive*) via which the library commands are passed. This setting is important when a drive (or cable) fails:

- When the master drive fails, the robot can no longer be controlled (and the device consequently quits Random Mode).
- When the other drive fails, the first logical device can be used again. However, here it must be borne in mind that the next time the tape emulation is assigned (`/ATTACH-DEVICE` command) the second device cannot be recognized and therefore performs no partitioning. The cartridges of the second device are therefore also available to what was originally the first device, which under some circumstances can lead to unwanted results. If the tape library is switched on and detects the defect or the absence of a drive, it automatically switches over the library master drive. In this case, too, the tape library is displayed to BS2000 as a non-partitioned device following the next assignment (`/ATTACH-DEVICE` command).

**i** Note the following in the case of a tape library with two drives in Sequential Mode:

Logical partitioning of the tape drive takes place in X2000 without it being stored in the tape library. In Sequential Mode only the first drive is used. When a cartridge is ejected, the next cartridge from the next highest slot is automatically loaded. In this case the logical partitioning limits of X2000 are not complied with. When the BS2000 command `/UNLOAD-TAPE` is used or in the case of backup operations with a change of tape, these special features must be borne in mind. You are therefore recommended to insert cartridges in Sequential Mode only “manually” via OCP or to insert and swap the RMU. As options such as *Autoload* and *Loop* are global within the device, you are recommended not to enable these in BS2000 mode.

### Cleaning the drives

LTO drives do not need to be cleaned regularly; they request a cleaning tape when one is required.

The tape library recognizes manual cleaning mode and automatic cleaning mode. To ensure BS2000 operates problem-free, you must set automatic cleaning mode:

- > Insert a cleaning cartridge in mailslot 3.
- > Enable automatic cleaning mode with *Auto Clean*.

## 4.2.7 Error handling

Problem	Solution
<b>Power supply</b>	
No display messages appear	<ul style="list-style-type: none"> <li>• Make sure the power is connected.</li> <li>• Make sure the power switch is on.</li> <li>• Power cycle the library.</li> <li>• Contact Customer Support.</li> </ul>
<b>Tape movement</b>	
Tape stuck in drive	<ul style="list-style-type: none"> <li>• Detach the tape library while BS2000 is operating ( /DETACH-DEVICE ). This eliminates the BS2000 software as a problem source.</li> <li>• Power cycle the library, allow it to complete initialization, which in rare cases can take as long as 10 minutes, and then retry unloading the tape using the library operator control panel.</li> <li>• Allow the tape drive to complete all operations. This may take as long as 10 minutes if you reset or cycle power on the library while the cartridge is positioned at the physical end of the media.</li> <li>• Contact Customer Support.</li> </ul>
Tape stuck in storage slot	See <a href="#">section "Removing stuck tapes from slots"</a> .
<b>Media</b>	
Cleaning or data cartridge incompatible with drive	Make sure you are using recommended data and cleaning cartridges, see <a href="#">"LTO tape cartridges"</a> . The library automatically unloads incompatible cartridges, the Media Attention LED flashes, and an exclamation point (!) is displayed in the inventory display for the indicated slot number. Export the media in order to clear the state.
Cannot write to or read from tape	<ul style="list-style-type: none"> <li>• Make sure that the cartridge is write enabled (move the write-protect switch to the enabled position).</li> <li>• Make sure you are using a recommended data cartridge, see <a href="#">"LTO tape cartridges"</a> .</li> <li>• Make sure you are using an Ultrium cartridge that has not been degaussed. Do not degauss Ultrium cartridges.</li> <li>• Make sure that the cartridge has not been exposed to harsh environmental or electrical conditions and is not physically damaged in any way.</li> <li>• Retry the operation with a different, known good tape.Clean the tape drive.</li> </ul>
<b>Cleaning</b>	

Cannot load the cleaning cartridge	<ul style="list-style-type: none"> <li>• Make sure you are using a recommended cleaning cartridge, see <a href="#">"LTO tape cartridges"</a>.</li> <li>• Contact Customer Support.</li> </ul>
<b>Errors displayed on operator control panel</b>	
"!" in OCP inventory display	See <a href="#">"Media"</a> .
There is an error code on the LCD screen	Contact Customer Support (see <a href="#">section "Tape library error codes"</a> ).
<b>Bad performance</b>	
	<ul style="list-style-type: none"> <li>• Try a new cartridge. A marginal cartridge can cause performance problems due to bad spots on the tape requiring retries.</li> <li>• Backing up data that compresses poorly or is already compressed will lower performance.</li> <li>• Check the size of the files. Small file size can impact performance. Clean the tape drive.</li> </ul>
<b>Media attention LED issues</b>	
Contamination by loose debris.	Avoid contamination of the library. Cartridges should be stored vertically in their plastic cases. Cleaning the tape drive when requested by the library.
Non-acclimated media	A cartridge should be acclimated for at least 24 hours before being used, particularly if it has been stored at a substantially different temperature or level of humidity than the tape library.
Cartridge is incompatible	Make sure you are using recommended data and cleaning cartridges, see <a href="#">"LTO tape cartridges"</a> .
Expired cleaning cartridge	A recommended cleaning cartridge is good for 50 library cleans.
Defective / contaminated media	<p>If the Media Attention LED is cleared and - although the drive has been cleaned - immediately re-displays each time a particular cartridge is reloaded that cartridge should be suspected as being defective.</p> <ul style="list-style-type: none"> <li>• Export the cartridge and load a known good cartridge. In some cases, a cartridge can be worn out or be defective.</li> <li>• Any cartridge that is suspected of being defective or contaminated should NOT be reused in any drive.</li> </ul>

Table 6: Error handling ETERNUS LT40 S2

This section covers the following topics:

- [Removing stuck tapes from slots](#)
- [Tape library error codes](#)

#### 4.2.7.1 Removing stuck tapes from slots

**i** Detach the tape library while BS2000 is operating (/DETACH-DEVICE) before you start your manual work on the tape library.

1. Unlock the magazines and remove them from the tape library
  - > via OCP, see [section "Removing and replacing a magazine using the OCP"](#).
  - > via RMU, see [section "Removing and replacing a magazine using the RMU"](#).
2. The finger holes on the back side of the magazines (see figure) allow the user to pull the cartridges out of the slot. Remove and insert the cartridge mechanically. Repeat the process several times.

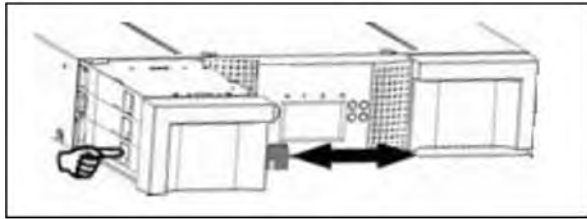

Figure 33: Removing stuck tapes from slot

3. During this process the burr will be removing.
4. Insert cartridge in the magazine.
5. Put the magazine back to the tape library.



## Magazine does not unlock

If you are not able to remove the magazines using the OCP or the RMU, an emergency release mechanism is available.

**i** Detach the tape library while BS2000 is operating (`/DETACH-DEVICE`) before you start your manual work on the tape library.

### **!** CAUTION!

**Use only in case of emergency!**

1. Unplug the power cord from the library.
2. Find the access holes for the right and left magazines.

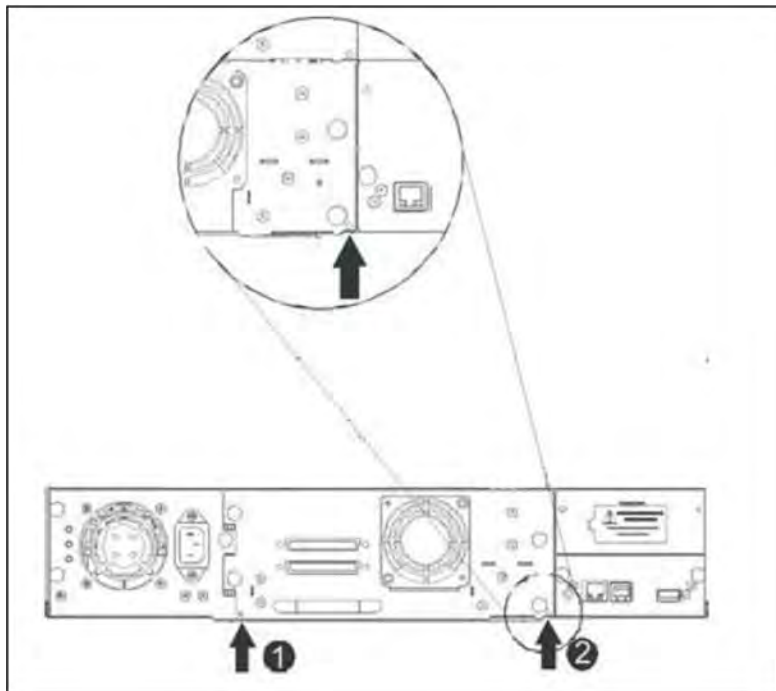

Figure 34: Access holes for the left and right magazine

No.	Meaning
1	Right magazine release
2	Left magazine release

3. To manually release the magazines, push the end of a straightened paper clip into the access hole for each magazine at the back of the library. While holding the paper clip, have a second person pull the magazine out of the front of the unit.

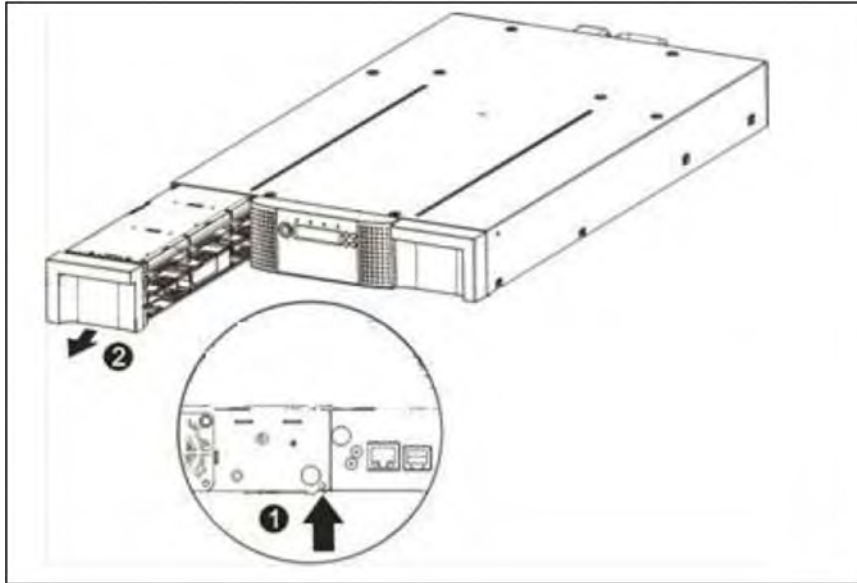

Figure 35: Remove the left magazine

<b>Step</b>	<b>Process</b>
1	Insert pin into access hole
2	Release and remove magazine

If there are additional tapes still in the library, or if you were unable to manually remove the magazines and drive, contact Customer Support for further instructions.

### 4.2.7.2 Tape library error codes

If an error occurs during operation of the library, the library stops the current operation and displays an error code on the LCD screen.

**i** If an error message is issued, please notify Customer Support.

#### Example error code

```
EVENT -6  
A5 F1
```

where:

- Sequence number -6 indicates the position in sequence list, 0 being the most recent
- Log shows a load error (code A5 = fan error, sub code F1 = caused by the fan at the back connector plate).

The event log with the library also includes a date stamp for each event. Press the ENTER key to display the associated timestamp in the following format:

```
ddd:hh:mm:ss:HH
```

where:

```
ddd: days  
hh: hours  
mm: minutes  
ss: seconds  
HH: 1/100 seconds
```

### 4.3 ETERNUS DX100 S4 disk storage system

This device is supported on SU310 only.

The scalable and unified Fujitsu Storage ETERNUS DX100 S4 delivers enterprise-class functionality to small and medium-sized companies and subsidiaries with an excellent price/performance ratio. It is the perfect solution when consolidating data for server virtualization, e-mail, databases and business applications as well as centralized file services. Simple, intuitive system management, highly flexible connectivity, granular scalability and the option to upgrade to a higher system significantly reduce operational and migration costs. The ETERNUS DX family architecture lets customers benefit from software options, such as thin provisioning, automatic storage tiering, transparent failover and quality of service management even as early as the entry-level class. This all contributes to better business support and guarantees continuity and efficiency in daily operations.



Figure 36: ETERNUS DX100 S4

For further information on DX100 S4, please refer to the original documentation, e.g. <https://www.fujitsu.com/emeia/products/computing/storage/disk/eternus-dx/dx100-s4/>.

## 4.4 ETERNUS LT140 tape library

This device is supported on SU310 only.

The Fujitsu Storage ETERNUS LT140 is a cost-effective tape library providing extreme expansion flexibility up to 8400 TB. Starts with a 3U base unit and 20 slots while the pay-as-you-grow concept provides high investment protection that enables to scale and address long-term data storage requirements. Highly automated, simple and remote operation allows ease of use even at remote sites. The standardized LTO technology features high capacity, high speed and low cost that provide hardware-based data encryption offering enhanced security and compliance.

The LT140 tape library occupies three height units in the rack. Available are LTO drives with Fibre Channel connection of the generation LTO-6, LTO-7 and LTO-8 (depending on availability). For the drives, LTO-(n) drives are read and write compatible with drives LTO-(n-1) and read compatible with LTO-(n-2) (the latter only for n=6, 7). Only one drive and only Fibre Channel direct connection are supported.



Figure 37: ETERNUS LT140

For further information on LT140, please refer to the original documentation, e.g. <https://www.fujitsu.com/emeia/products/computing/storage/tape/eternus-lt/lt140/>.

## 5 Related publications

You can find the following BS2000 manuals on the manual server with the BS2000 documentation at <http://bs2manuals.ts.fujitsu.com>.

Other manuals, for example descriptions of the FUJITSU PRIMERGY and PRIMEQUEST servers, can be found on the general FUJITSU manual server at <http://manuals.ts.fujitsu.com>.

- [1] **FUJITSU Server BS2000 SE Series  
Basic Operating Manual**
- [2] **FUJITSU Server BS2000 SE Series  
Server Unit /390  
Operating Manual**
- [3] **FUJITSU Server BS2000 SE Series  
Server Unit x86  
Operating Manual**
- [4] **FUJITSU Server BS2000 SE Series  
Additive Components  
Operating Manual**
- [5] **FUJITSU Server BS2000 SE Series  
Operation and Administration  
User Guide**
- [6] **FUJITSU Server BS2000 SE Series  
Security Manual  
User Guide**
- [7] **FUJITSU Server BS2000 SE Series  
Quick Guide  
User Guide**