

**Note:**

- ① - Contact livré non assemblé  
*Contact delivered unassembled*
- ② - Câble compatible: 311501  
*Compatible cable: 311501*
- ③ - Matière / Material
  - Douille extérieure et douille intérieure: alliage de cuivre  
*Outer socket and inner socket: copper alloy*
  - Ferrule: laiton  
*Ferrule: brass*
  - Fourreau: acier inoxydable  
*Fourreau: stainless steel*
  - Isolants: PTFE  
*Insert: PTFE*
  - Bague de démontage: thermo plastique  
*Extraction tool: thermo plastic*
- ④ - Traitement / Protection
  - Douille extérieur, douille centrale et ferrule: dorure sur nickel  
*Outer socket, outer socket and ferrule: gold over nickel*
  - Fourreau: passivation  
*Hood: passivation*

Douille Coax T12 50 Ohms  
Socket Coax S12 50 Ohms  
Arinc 600  
Ref : 603760

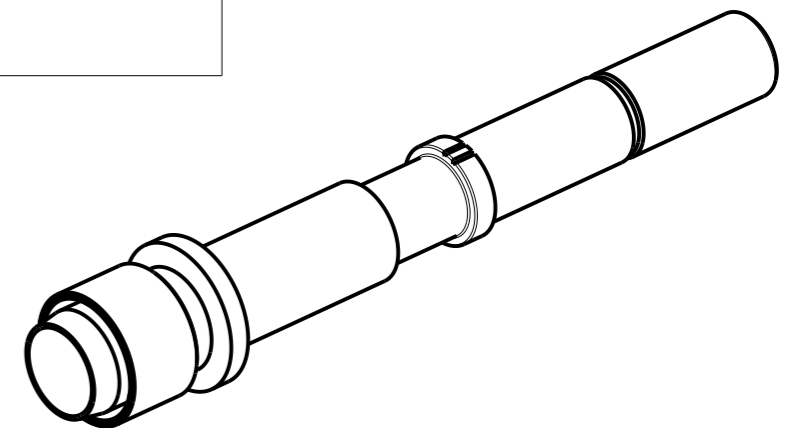

MODIFICATIONS	A	Plan original	ECHELLE
			6

Amphenol Socapex  
BP 29 - 74311 THYEZ CEDEX

DESSIN: M.PRUD'HOM le 29/05/17	
TECHNIQUE: L.LAGRANGE le 31/05/17	
A	
182-PLC-049-00 1/1	