

Douille coax T12 50 Ohms  
 Socket contact S12 50ohms  
 Arinc 600  
 Ref : 603712

**Note:**

- ① - Contact livré non assemblé  
*Contact delivered unassembled*
- ② - Câble compatible: 311901 et 352001  
*Compatible cable: 311901 and 502001*
- ③ - Matière / Material
  - Douille extérieure et douille intérieure: alliage de cuivre  
*Outer socket and inner socket: copper alloy*
  - Ferrule: laiton  
*Ferrule: brass*
  - Fourreau: acier inoxydable  
*Fourreau: stainless steel*
  - Isolants: PTFE  
*Insert: PTFE*
  - Bague de démontage: thermo plastique  
*Extraction tool: thermo plastic*
- ④ - Traitement / Protection
  - Douille extérieur, douille centrale et ferrule: dorure sur nickel  
*Outer socket, outer socket and ferrule: gold over nickel*
  - Fourreau: passivation  
*Hood: passivation*

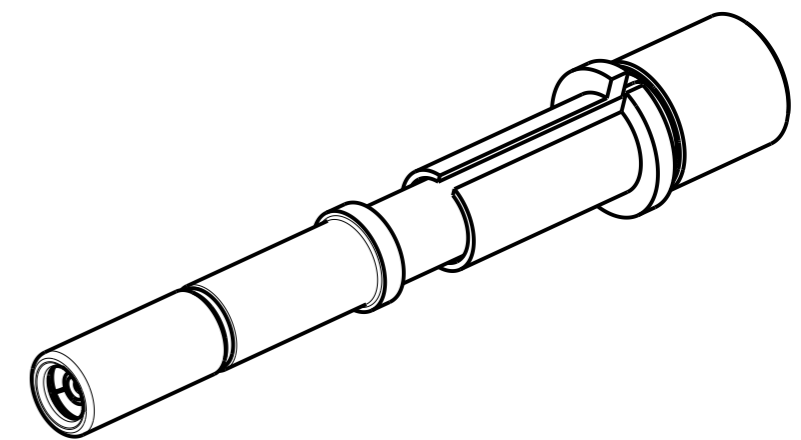

MODIFICATIONS	A	Plan original	ECHELLE	Amphenol Socapex	DESSIN: M.PRUD'HOM 1e 12/04/17
			6		TECHNIQUE: L.LAGRANGE 1e 30/05/17
				BP 29 - 74311 THYEZ CEDEX	A
					182-PLC-032-00 1/1