

DANS LE BUT CONSTANT D'AMELIORER SES PRODUITS, Amphenol Socapex SE RESERVE LE DROIT D'EN MODIFIER TOUTE COTE OU CARACTERISTIQUE.
IMP 036 A

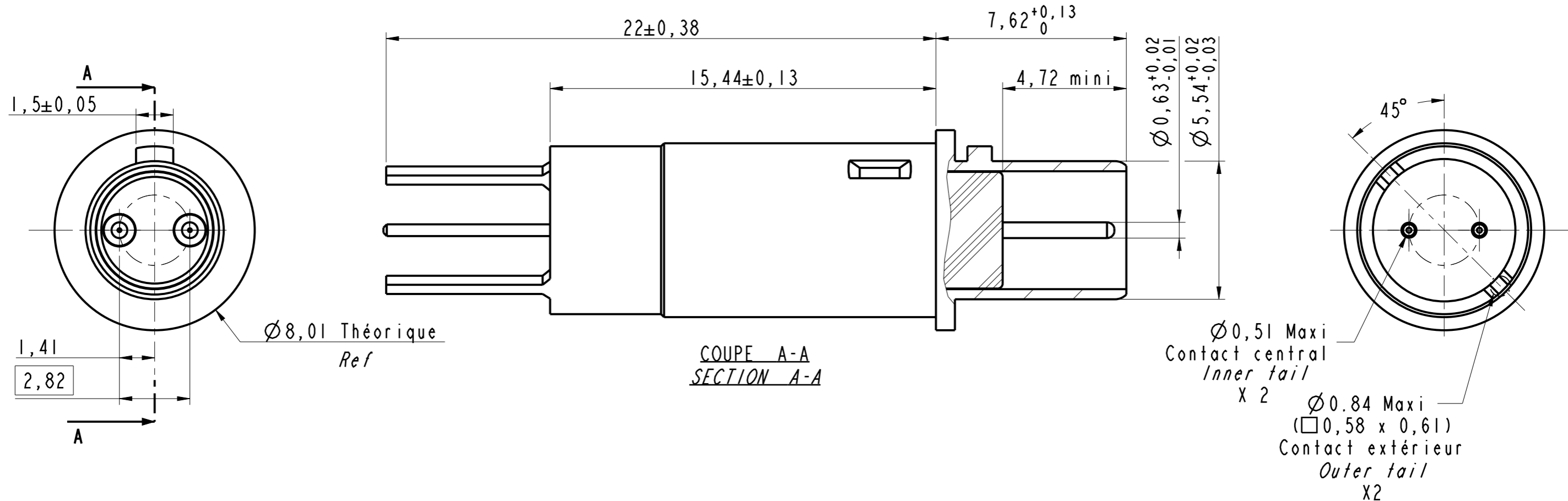

PERCAGE CIRCUIT IMPRIME
Vue de la face avant du contact
PCB DRILLING
View of front face of contact

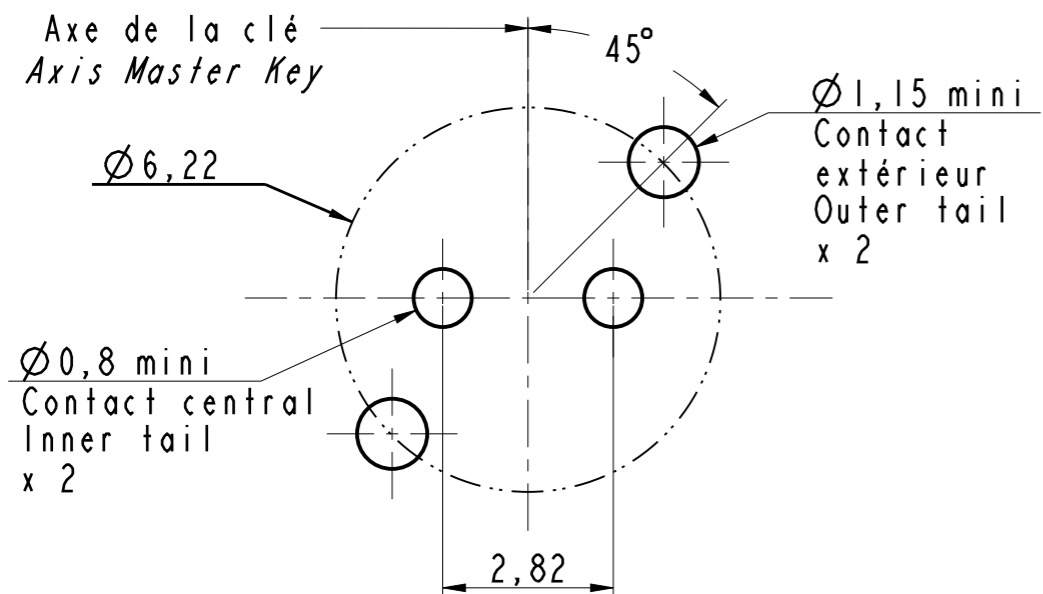

Differential Twinax Male T8 lg 22 LJT-TV
 Pin Differential Twinax S8 lg 22 LJT-TV
 Ref: 603271

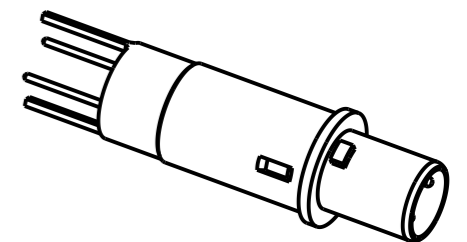

MODIFICATIONS	A	Plan original	ECHELLE	Amphenol Socapex	DESSIN: M.PRUD'HOM le 18/12/15
			6		TECHNIQUE: E.MONET le 04/01/16
				BP 29 - 74311 THYEZ CEDEX	A
					173-PLC-1431-00 1/1