

Note:

- ① - Contact livré non assemblé
Contact delivered unassembled
- ② - Cable compatible : P569227A
Compatible cable : P569227A
- ③ - Outils de sertissage:
 - Contact extérieur: outils (à définir) avec positionneur
 - Contact intérieur: outils M22520/2-01 avec positionneur K709 en position (5)*Crimping tools:*
 - Outer contact : tool (to be defined) with positioner
 - Inner contact: tool M22520/2-01 with positioner K709 in position (5)
- ④ - Température d'utilisation: -50°C à 150°C
Application temperature: -50°C to 150°C

Broche Differential Twinax
Pin Differential Twinax
Ref: 612002

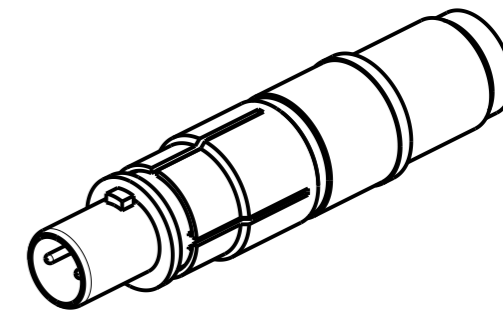

MODIFICATIONS	A	Plan original	ECHELLE	Amphenol Socapex BP 29 - 74311 THYEZ CEDEX	DESSIN: M.LAINE 1e 11/07/18
			5		TECHNIQUE: L.LAGRANGE 1e 11/07/18
					A
					172-PLC-134-00 1/1