

DANS LE BUT CONSTANT D'AMELIORER SES PRODUITS, Amphenol Socapex SE RESERVE LE DROIT D'EN MODIFIER TOUTE COTE OU CARACTERISTIQUE.
IMP 036 A

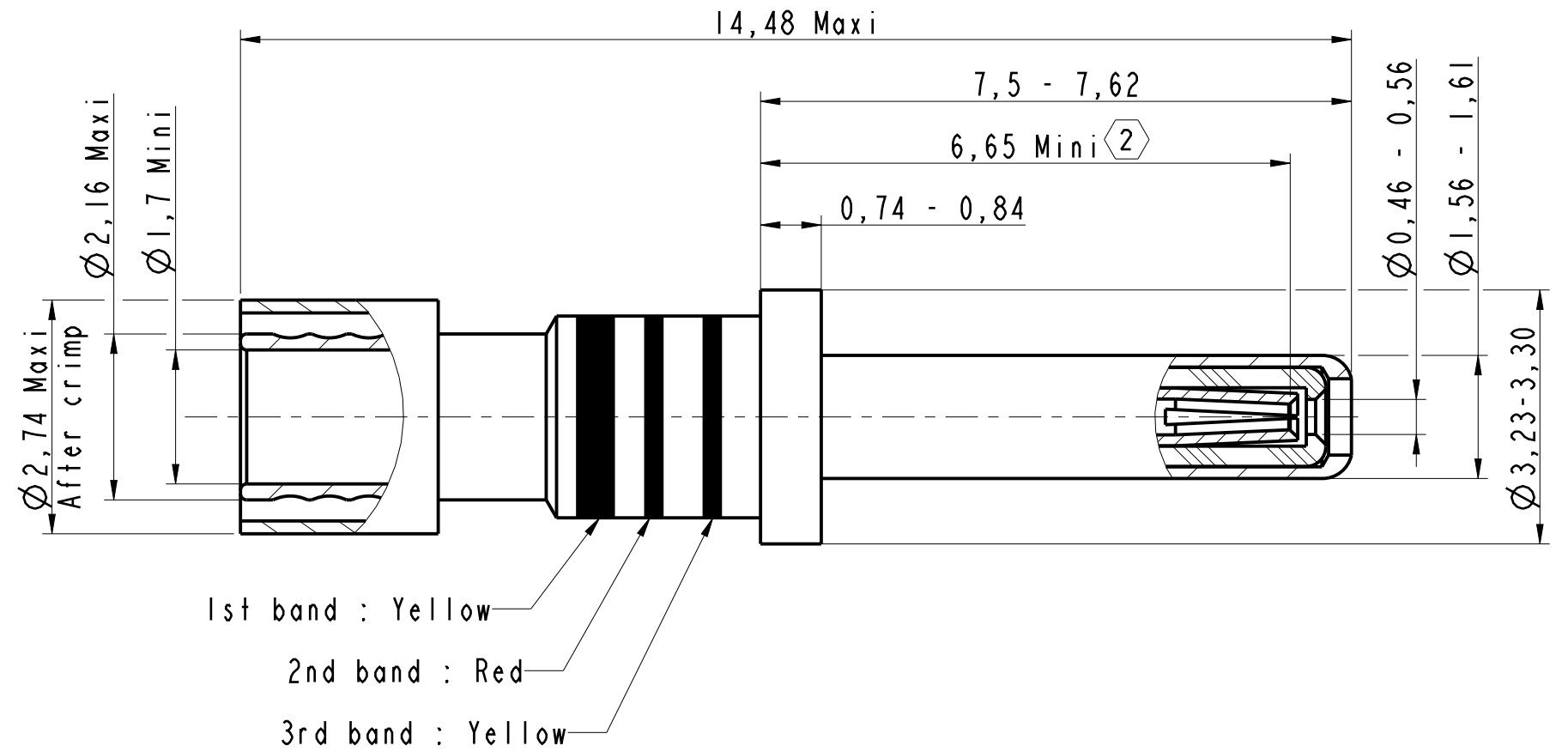

PIN CRIMP COAX CONTACT
SIZE 16
M39029/76-424
P/N : 071094

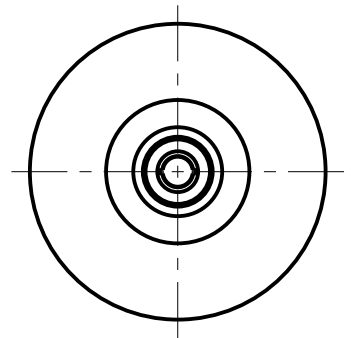
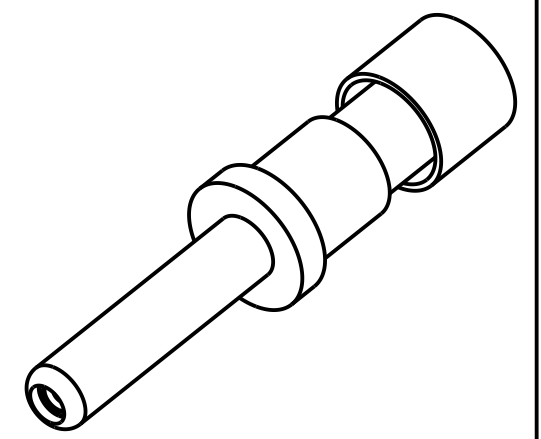

NOTE :

- ① - Crimping tool
 - Inner contact : Tool M22520/2-01, positioner M22520/2-35
 - Outer contact : Tool M22520/4-01, positioner M22520/4-02
- ② - Point at which a square ended pin of the same basic diameter as the mating contact first engages the inner contact spring.
- ③ - Cables: RG-174A/U, RG-188A/U, RG-161/U, RG-187A/U, RG-316/U, RG-179B/U, HAVEG 8100207, TIMES (HS-179) AA3248, TELEDYNE 11299 and Raychem 7528H1424.

MODIFICATIONS	B	MMIN 25/10/16	ECHELLE
			12

Amphenol Socapex
BP 29 - 74311 THYEZ CEDEX

DESSIN: M.PRUD'HOM 1e 12/10/16	
TECHNIQUE: E.MONET 1e 25/10/16	
B	
172-PLC-038-00 1/1	