

Douille Quadrax 100 ohms  
Contact Socket Quadrax 100 ohms  
Ref: 603436

Notes:

- ①- Embalage incluant la douille quadrax 900338 avec manchon souple  
*Package including socket quadrax 900338 with soft sealing boot*
- ②- S'accouple avec D38999 broche quadrax 900330  
*Mates with D38999 quadrax pins 900330*
- ③- Outil de sertissage:  
Contact extérieur outil - M22520/5-01, mors M22520/5-45(fermeture hex A)  
Contact intérieur outil - M22520/2-01, positionneur Daniels K709 (M22520/2-37)  
*Crimping Tools:*  
Outer contact - M22520/5-01 tool, M22520/5-45 die set (hex closure A)  
Inner contacts - M22520/2-01 tool, Daniels K709 (M22520/2-37) Positioner
- ④- Câble quadrax Tensolite NF24Q100 (100 ohms) ou équivalent  
*Terminates quadrax cable tensolite NF24Q100 (100 ohm) or equivalent*
- ⑤- Outil d'extractrion: M81969/14-06  
*Extraction tool: M81969/14-06*
- ⑥- Dimension entre crochet : dimention en inch  
*Dimensions in bracket : dimensions in inch*

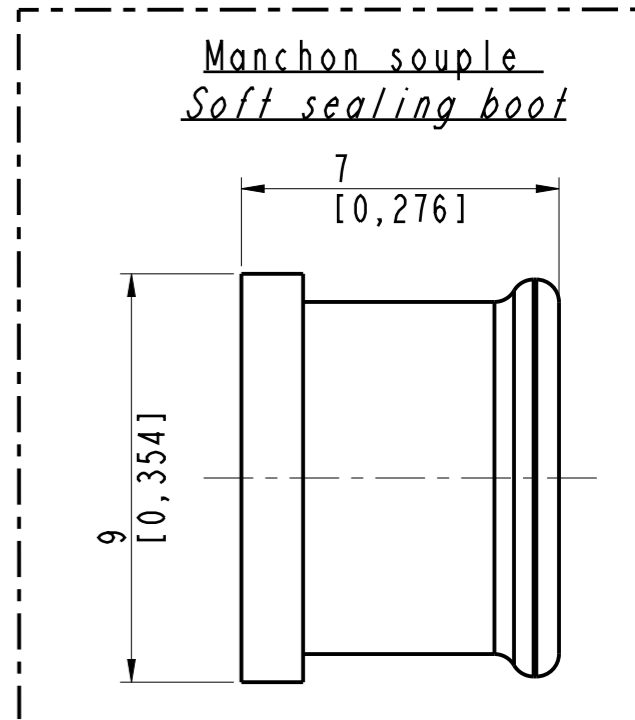

MODIFICATIONS	A	Plan original	ECHELLE
			5

Amphenol Socapex  
BP 29 - 74311 THYEZ CEDEX

DESSIN: M.PRUD'HOM 1e 03/05/16	
TECHNIQUE: L.LAGRANGE 1e 11/05/16	
A	
172-PLC-026-00 1/1	