

DANS LE BUT CONSTANT D'AMELIORER SES PRODUITS, Amphenol Socapex SE RESERVE LE DROIT D'EN MODIFIER TOUTE COTE OU CARACTERISTIQUE.
IMP 036 A

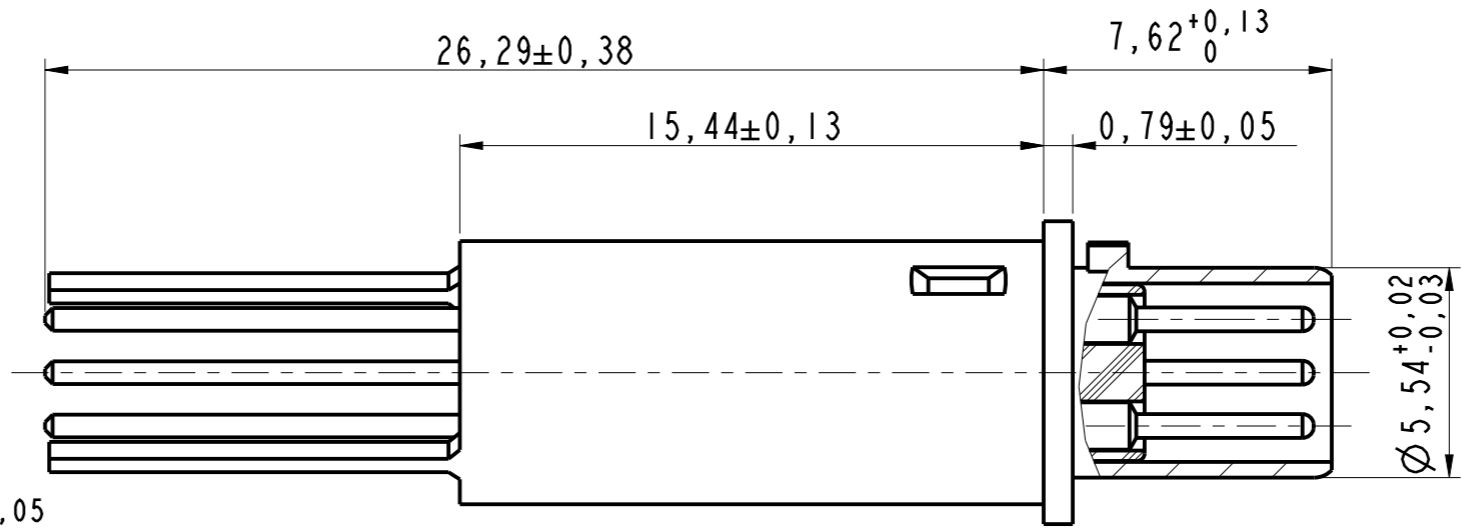

COUPE A-A
SECTION A-A

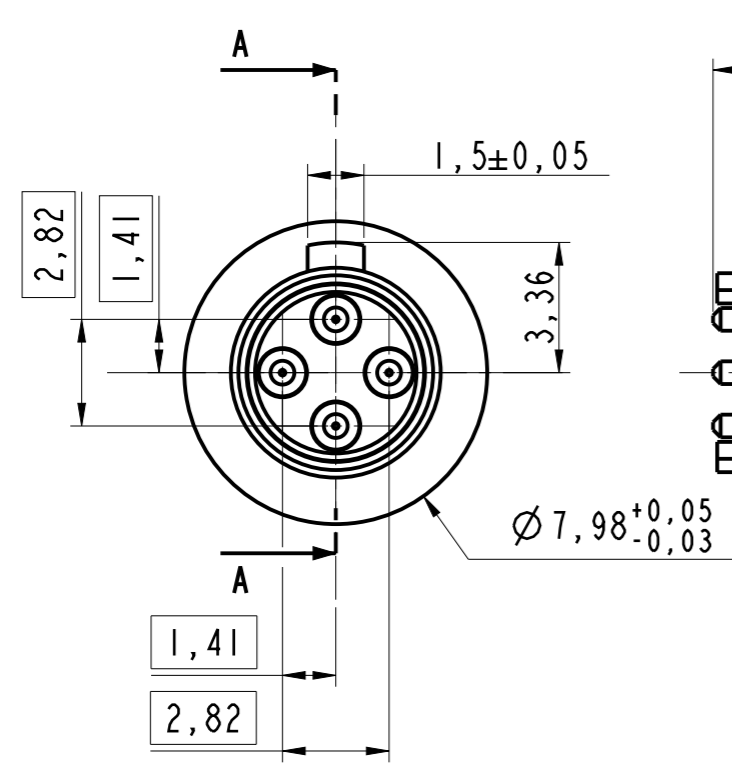
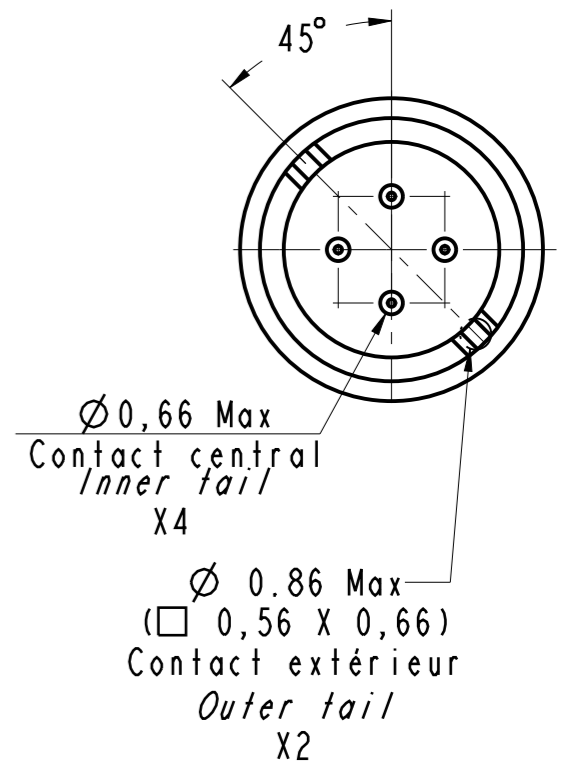

PERCAGE CIRCUIT IMPRIME
Vue de la face avant du contact
PCB Drilling
View of front face of contact

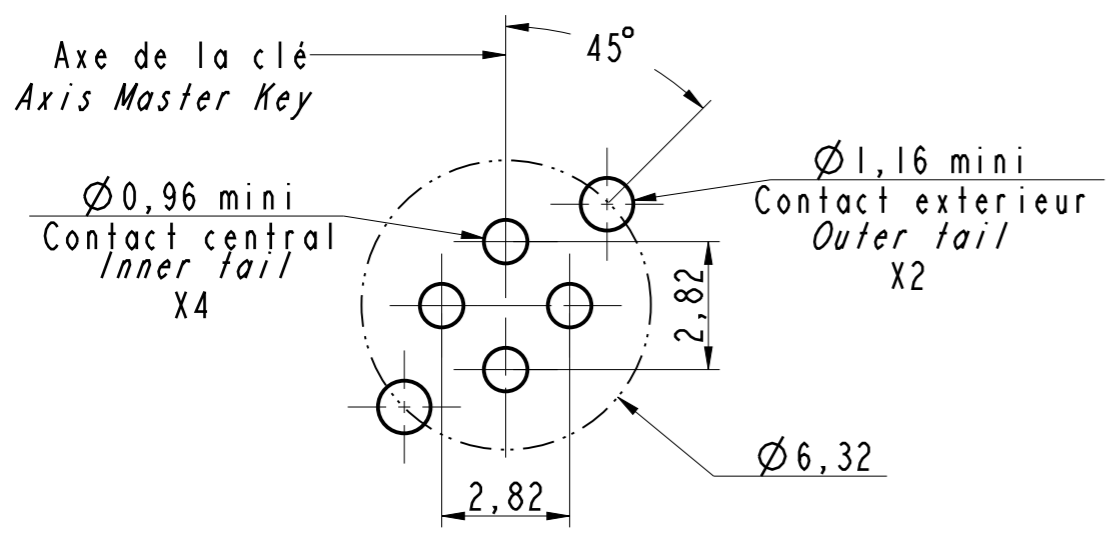

BROCHE QUADRAX LI T8 100 ohms
PIN CONTACT QUADRAX LI S8 100 ohms
Ref : 600512

Note:

① - Outil d'extraction M81969 / 14-12
Extraction tool M81969 / 14-12

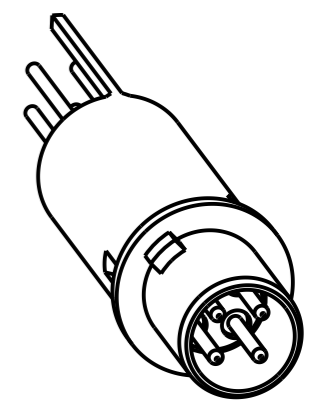

MODIFICATIONS	B	MMIN 23/03/17	ECHELLE	Amphenol Socapex BP 29 - 74311 THYEZ CEDEX	DESSIN: M.PRUD'HOM 1e 03/02/16
			5		TECHNIQUE: L.LAGRANGE 1e 23/03/17
					B